

Genie® S®-85 XC™

Specifications

Models	S-85 XC	
Measurements	US	Metric
Working height max. ⁽¹⁾	91 ft	27.91 m
Platform height max.	85 ft	25.91 m
Horizontal reach max.	74 ft 6 in	22.71 m
Below ground reach	8 ft 8 in	2.64 m
A Platform length (8 ft/6 ft)	3 ft/2 ft 6 in	0.91 m/0.76 m
B Platform width (8 ft/6 ft)	8 ft/6 ft	2.44 m/1.83 m
C Height - stowed	9 ft 2 in	2.80 m
D Length - stowed	40 ft 7 in	12.37 m
D Length - storage/transport (jib tucked under)	33 ft 8 in	10.25 m
E Width	8 ft 2 in	2.49 m
F Wheelbase	9 ft 4 in	2.85 m
G Ground clearance - center	15.8 in	0.40 m
H Height under counterweight	3 ft 9 in	1.14 m

Productivity

Lift capacity max. - unrestricted	660 lb	300 kg
Lift capacity max. - restricted	1,000 lb	454 kg
Number of Platform Occupants (restricted/unrestricted)		3/2
Platform rotation		160°
Jib length	5 ft	1.52 m
Vertical jib rotation (up/down)		133°
Turntable rotation		360°
Turntable tailswing	5 ft 3 in	1.60 m
Drive speed - stowed	3.0 mph	4.8 km/h
Drive speed - raised	0.5 mph	0.2 m/s
Gradeability - stowed ⁽²⁾		45%
Tilt sensor activation (front to back/side to side)		7°/5°
Turning radius - inside/outside	12 ft/21 ft 6 in	3.66 m/6.55 m
Tires		18-625

Power

Power		Diesel
Hydraulic tank capacity	40 gal	150 L
Fuel tank capacity	35 gal	132 L

Weight⁽³⁾ and Floor Loading⁽⁴⁾

Weight	39,500 lb	17,917 kg
Tire contact pressure	130 psi	896 kPa
Occupied floor pressure	395 psf	18.9 kPa

Sound and Vibration Levels

Sound Pressure level (ground workstation)	85 dBA
Sound Pressure level (platform workstation)	78 dBA
Vibrations	< 2.5 m/s ²

(1) The metric equivalent of working height adds 2m to platform height. The imperial equivalent adds 6ft to platform height.

(2) Gradeability applies to driving on slopes and may vary depending on options and machine configurations. See operator's manual for details regarding slope ratings.

(3) Weight refers to standard configuration and may vary depending on options and/or country standards.

(4) Floor loading information is approximate and may vary depending on options and machine configurations. It should be used only with adequate safety factors.

Range of motion S-85 XC

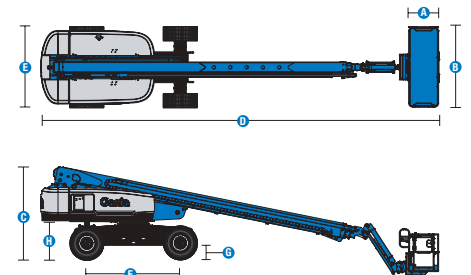
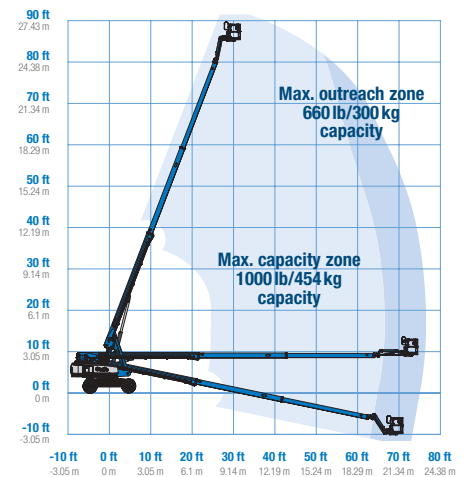

Boland Equipment Rentals

282 Hudson Street
Hackensack, NJ 07601

201-342-8020

www.berequipment.com



Genie® S®-85 XC™

Boland Equipment Rentals

201-342-8020

282 Hudson Street
Hackensack, NJ 07601

www.berequipment.com

SKU: Standard Model

- **S85XC001AF0003:** S-85 XC, 4WD
- **S85XC001AF0006:** S-85 XC, Lift Power 3kW, 4WD
- **S85XC001AF0002:** S-85 XC, Lift Power 12kW Welder Ready, 4WD

* Build to Order

Option availability	S	S+	BtO
Power			
74 hp, 55 kW, Deutz TD2.9L, Turbo Diesel, T4f (TRAX and 80/85)	✓	✓	✓
Cold weather package			○
Diesel air intake pre-cleaner			○
Positive air shutdown system			○
Second battery			○
Anti-restart engine protection	✓	✓	✓
Auto engine fault shutdown	✓	✓	✓
In cylinder glow plug (diesel only)	✓	✓	✓
Platform			
6ft/1.83m dual-entry platform with side swing gate			○
8ft/2.44m tri-entry platform with side swing gate	✓	✓	✓
Dual axis joystick steering	✓	✓	✓
Thumb rocker steering			○
Air line to platform			○
Control box covers		○	○
Lift Guard Full Mesh panels			○
Lift Guard Half Mesh panels			○
Light Package: drive and work lights		○	○
Platform auxiliary top rail			○
Lift Power 3kW AC Generator, 110V/60Hz			○
Lift Power 3kW AC Generator, 220V/50Hz			○
Lift Power 12kW Welder Ready			○
660lb/300kg & 1000lb/454kg dual load capacity with automatic envelope control	✓	✓	✓
Drive enable system	✓	✓	✓
Horn	✓	✓	✓
Lift Guard Contact Alarm	✓	✓	✓
Lift Tools Work Tray	✓	✓	✓
Platform load sense system	✓	✓	✓
Proportional controls	✓	✓	✓
Self-leveling platform	✓	✓	✓
Chassis			
Lift Connect Telematics	✓	✓	✓
Telematics-ready	✓	✓	✓
Lift Connect with Access Manager upgrade		○	○
Biodegradable hydraulic oil			○
Cold weather hydraulic oil			○
Fire resistant hydraulic oil			○
High floatation, air-filled tires		○	○
Rough terrain, foam-filled tires	✓	✓	✓
Rough terrain, foam-filled, non-marking tires		○	○
Deluxe hostile environment kit			○
Hostile environment kit			○
LPG tank 33.5 lb			○
Tow package			○
2 speed wheel motors	✓	✓	✓
Active oscillating axle	✓	✓	✓
Alarm package: includes flashing beacon and travel alarm	✓	✓	✓
Chassis tilt lift and drive function cut-out	✓	✓	✓
Descent, tilt and motion alarm	✓	✓	✓
Dual battery system	✓	✓	✓
Hour meter	✓	✓	✓
Hydraulic oil cooler	✓	✓	✓
Tech Pro Link connector	✓	✓	✓

Positive air shutdown system for Deutz engines only

- S Standard
- S+ Standard +
- BtO Build to Order
- ✓ Standard Features
- Options



Xtra Capacity



Rugged Terrainability



Lift Power



Genie Genuine Accessories⁽¹⁾

- Lift Tools Productivity Tools
- Lift Connect Telematics
- Tech Pro Link Handheld Device

(1) More accessories available from Genie Genuine Parts.

Product specifications are subject to change without notice or obligation. Photographs and/or drawings herein are for illustrative purposes only. Refer to the appropriate Operator's Manual for instructions on proper equipment use. Failure to follow instructions in the Operator's Manual may result in serious injury or death. The only warranty applicable to our equipment is the standard written warranty applicable to the particular product and sale and we make no other warranty, express or implied. Products and services listed may be trademarks, service marks or trade names of Terex Corporation and/or their subsidiaries in the USA and many other countries. Terex, Genie, Quality By Design, Xtra Capacity, Lift Power, Lift Guard, Lift Tools, Lift Connect and Tech Pro Link are registered trademarks of Terex Corporation or its subsidiaries.

09/23



TB80/TB86J

LARGE TELESCOPIC BOOM LIFTS



- Robust diesel telescopic boom lifts
- Available with and without a jib boom
- Powerful 4 wheel drive and 4 wheel steer
- Excellent performance on rough terrain
- Designed for construction applications

Boland Equipment Rentals
201-342-8020
www.berequipment.com

LARGE TELESCOPIC BOOM LIFTS TB80/TB86J

DIMENSIONS	TB80	TB86J
Max. working height	86 ft	92 ft
Max. platform height	80 ft	86 ft
Max. horizontal reach	71 ft 2 in	78 ft 3 in
Platform size	8 ft x 3 ft	8 ft x 3 ft
Overall width (A)	8 ft 6 in	8 ft 6 in
Overall length (B)	38 ft 8 in	42 ft 3 in
Stowed height (C)	9 ft 6 in	9 ft 6 in
Ground clearance	13 in	13 in

PERFORMANCE	TB80	TB86J
Platform capacity	500 lbs	500 lbs
Max. drive height	80 ft	86 ft
Max. wind speed	28 mph	28 mph
Max. drive speed (stowed)	3 mph	3 mph
Max. drive speed (elevated)	0.6 mph	0.6 mph
Jib length	n/a	6 ft 6 in
Jib working arc	n/a	135°
Platform rotation	170°	150°
Superstructure rotation (continuous)	360°	360°
Tailswing	78.5 in	78.5 in
Raise/lower time	195/175 seconds	230/210 seconds
Gradeability	40%	40%
Inside turning radius	7 ft 10 in	7 ft 10 in
Outside turning radius	15 ft 6 in	15 ft 6 in
Tires	15 x 625 foam filled lug	
Controls	proportional joystick	
Drive system	4 wheel drive	

POWER	
Power source	Kubota V2403 65hp diesel - Tier 4 Final

WEIGHT	TB80	TB86J
Weight	36,332 lbs	38,690 lbs

WORKING ENVELOPE

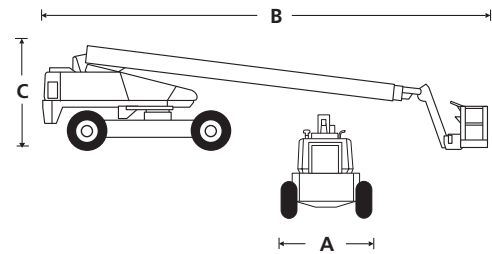
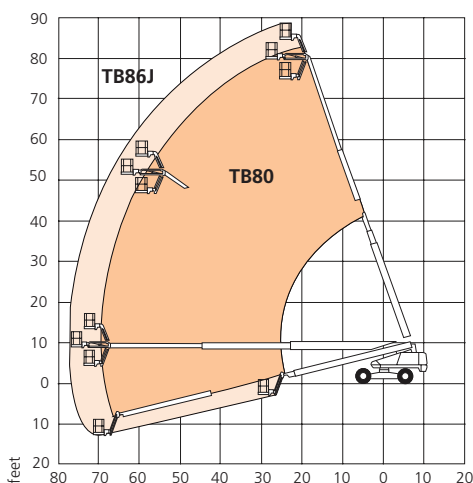

STANDARD FEATURES

- Snorkel Guard™ secondary guarding system
- Four wheel drive, steer and crab steer
- Hydraulic platform rotation
- 360° continuous turntable rotation
- Drive motion alarm
- Flashing amber light
- Foam filled lug tires
- Proportional drive, boom lift, swing & extend
- Rheostat control for jib & platform level
- Power line to platform
- 5° tilt alarm
- Tri-entry platform
- Dual lanyard attachment points
- Hour meter & on-board diagnostics display
- Horn
- 2 year parts & labor, 5 year structural warranty
- ANSI compliant

OPTIONS

- Special paint colors
- Airline to platform
- AC generator 110V/240V 2kW
- Non-marking tires
- Cold weather package
- Extreme cold weather package
- Extreme environment package
- Light package
- Tow kit
- Dual fuel
- Glazier package
- Utility package
- 12kW generator package
- 12kW generator/welder package
- Environmental hydraulic oil
- Tool tray



282 Hudson Street
Hackensack, NJ 07601

O: 201-342-8020

www.berequipment.com