

The Cameron mud pump is a single-acting reciprocating triplex mud pump built to accommodate discharge pressure up to 7,500 psi and fluid flow up to 964 galUS/min. These onshore mud pumps were designed with increased reliability, improved maintainability, and reduced weight and footprint.

Warning, Choking Hazard!

This kit contains small parts and is not intended for children under the age of 7. Please supervise children when building this creation.

This is not a LEGO® Product.

These are repurposed LEGO elements that have been repackaged or altered from their original form. LEGO is a trademark of the LEGO Group, which does not sponsor, authorize or endorse this product. The LEGO Group is not liable for any loss, injury or damage arising from the use or misuse of this product.

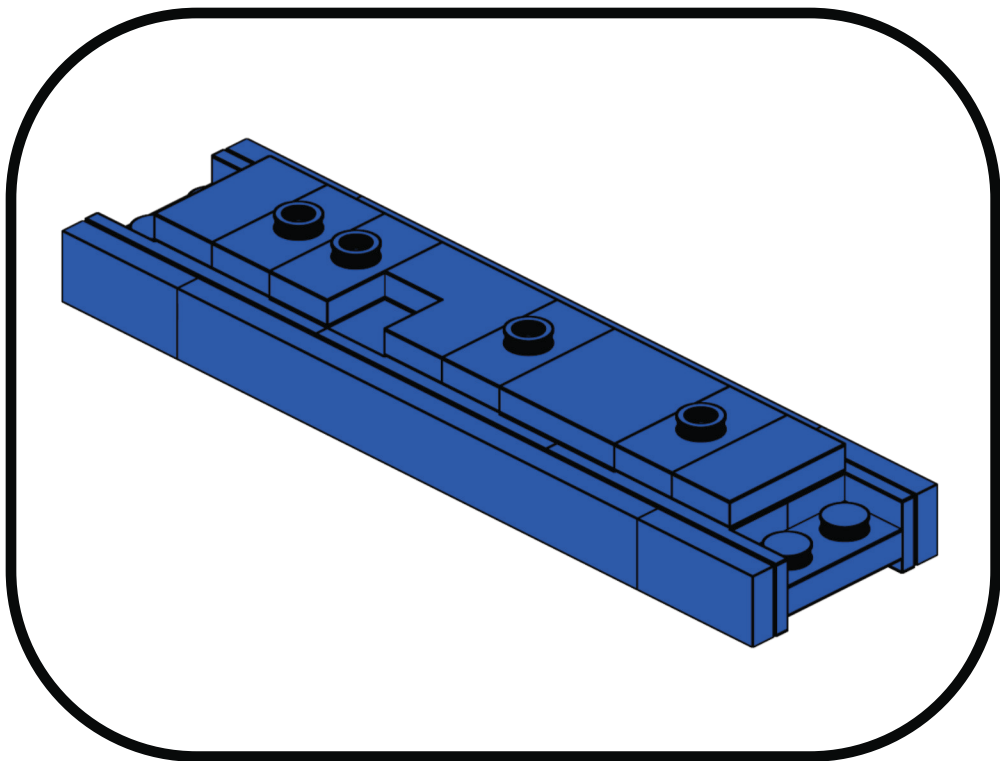

1

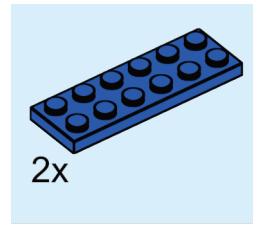

2x

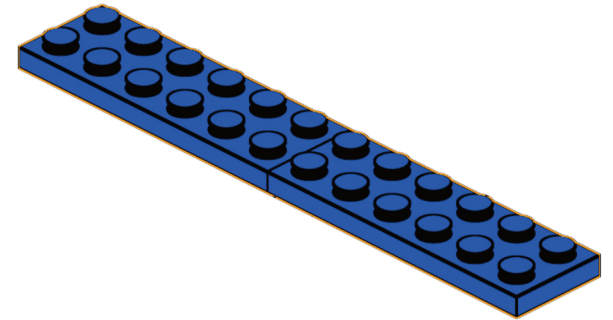

2

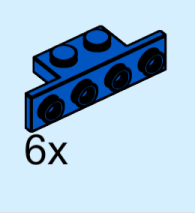

6x

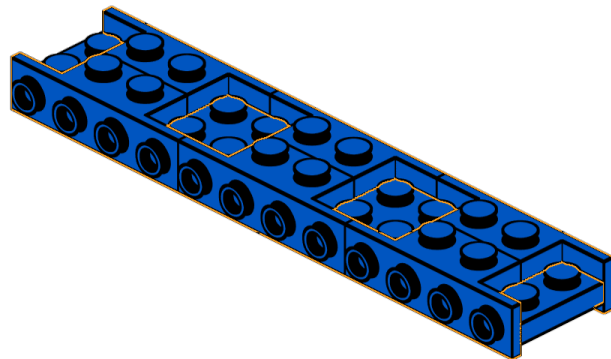

3

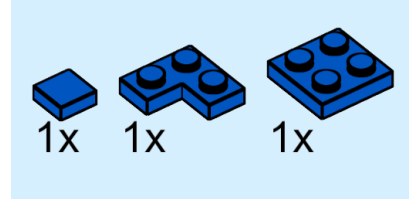

1x

1x

1x

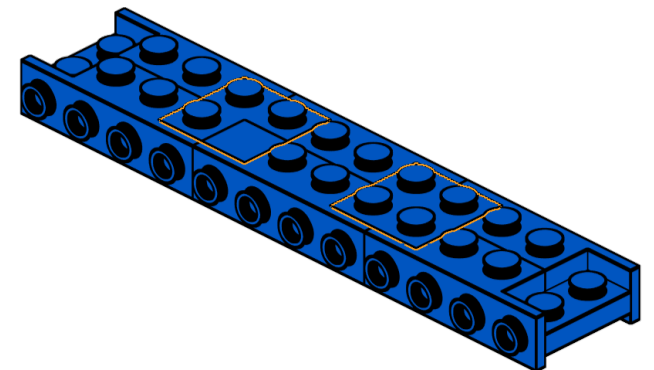

4

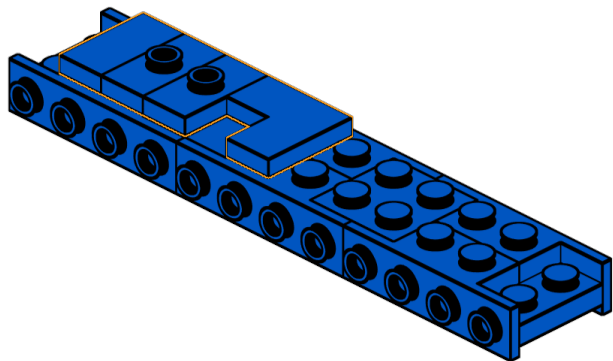
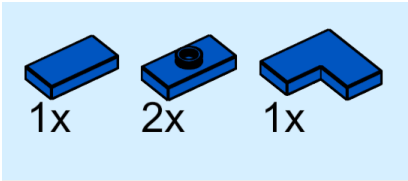

5

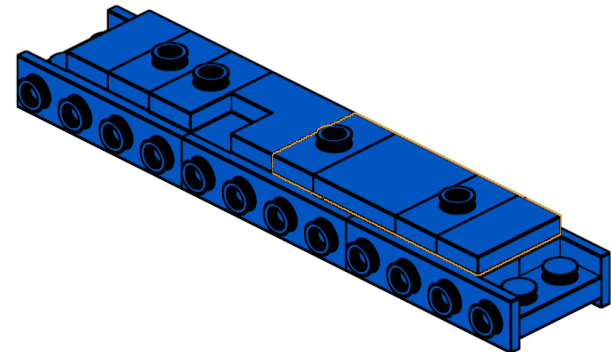
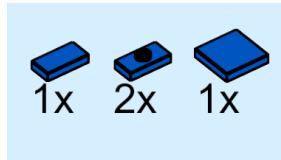

6

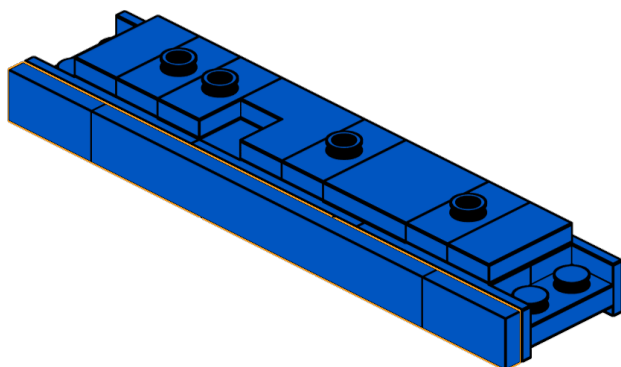
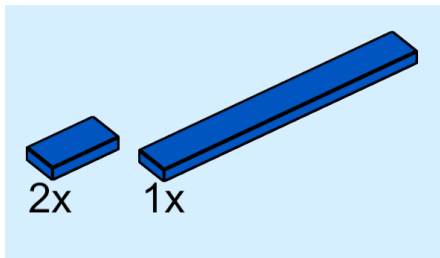

7

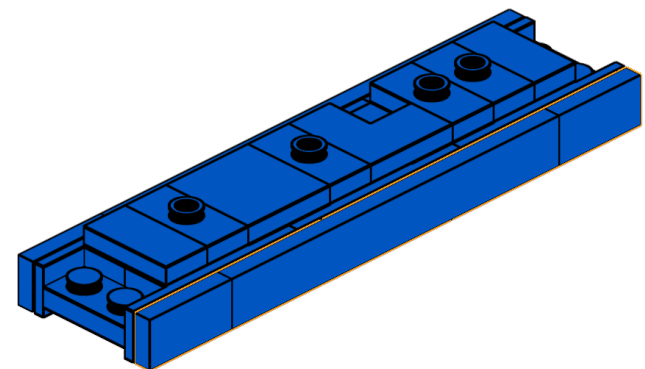
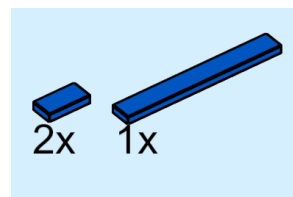

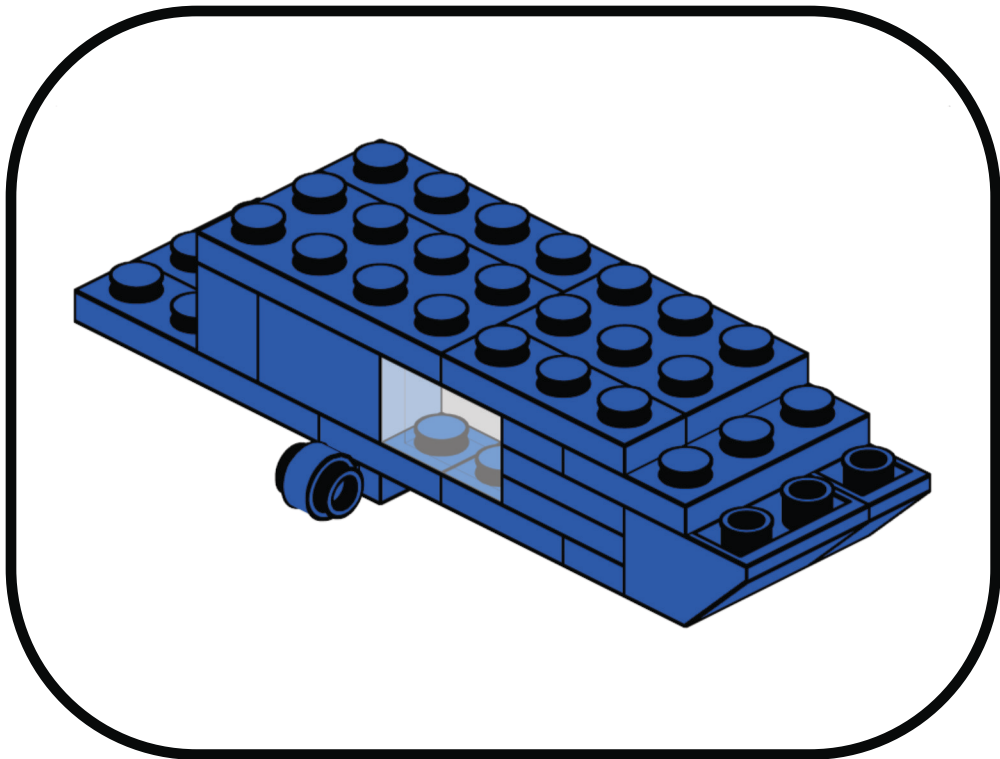

8

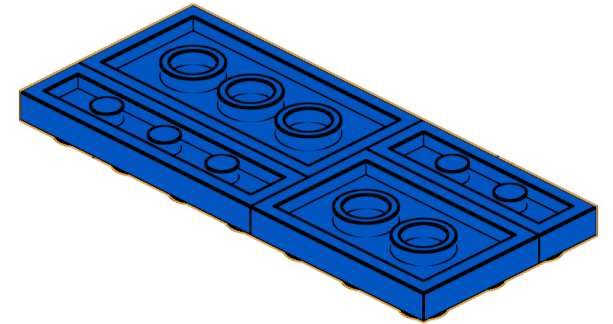
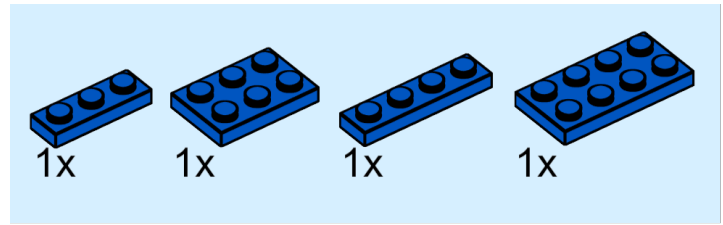

9

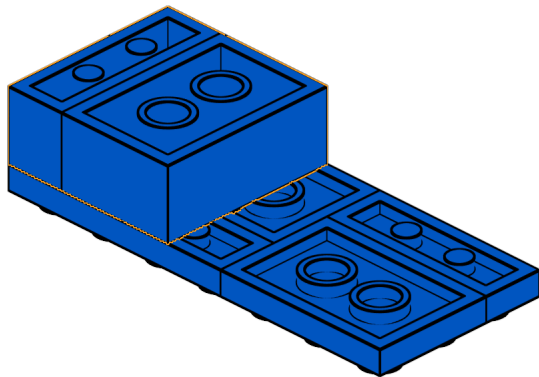
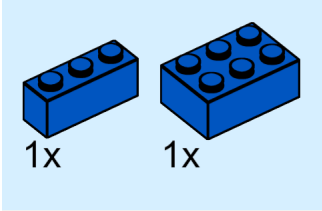

10

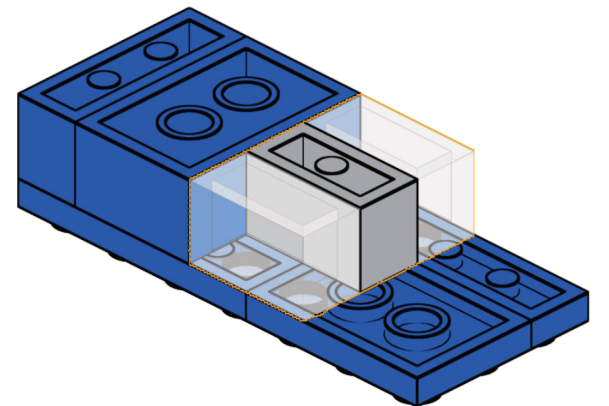
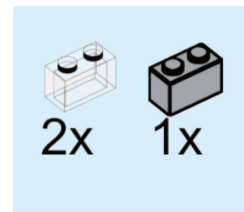

11

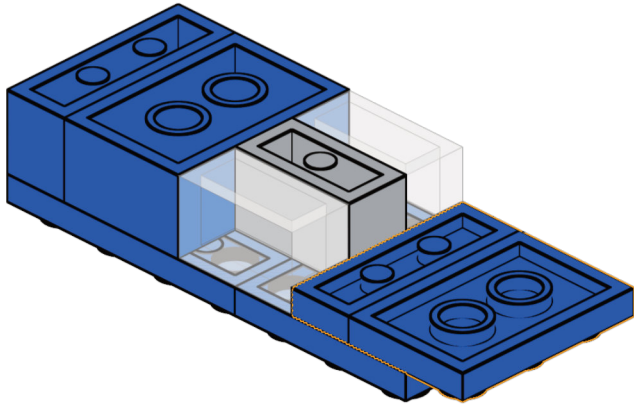
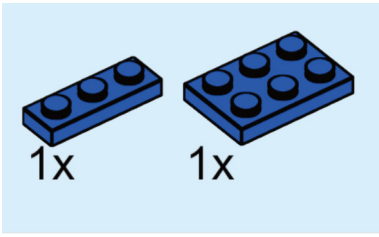

12

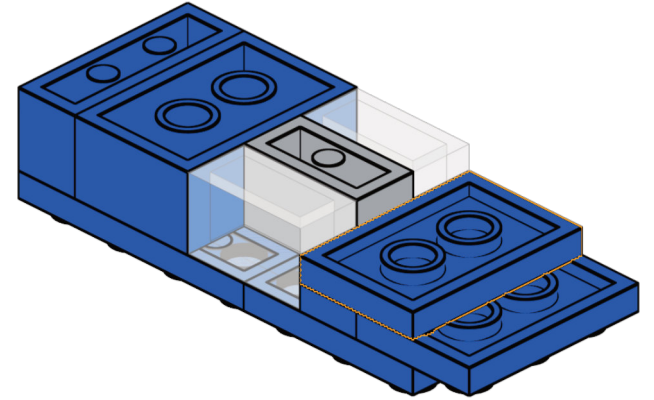
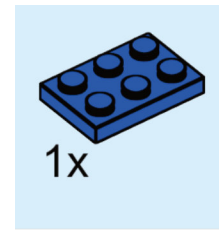

13

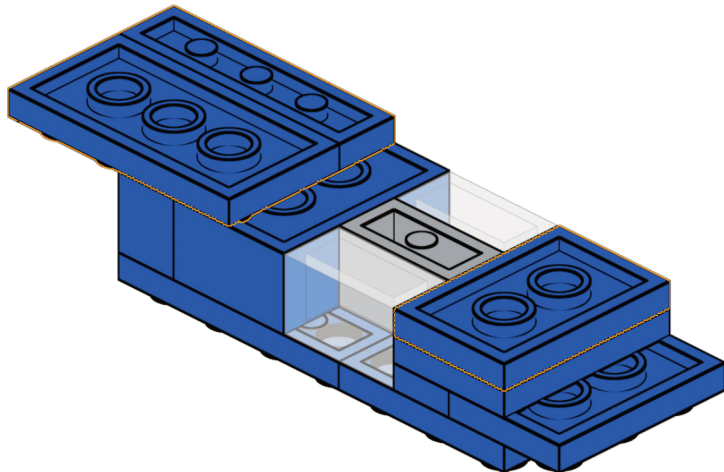
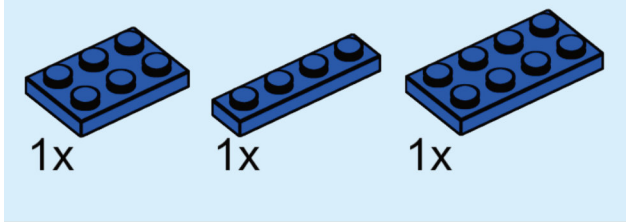

14

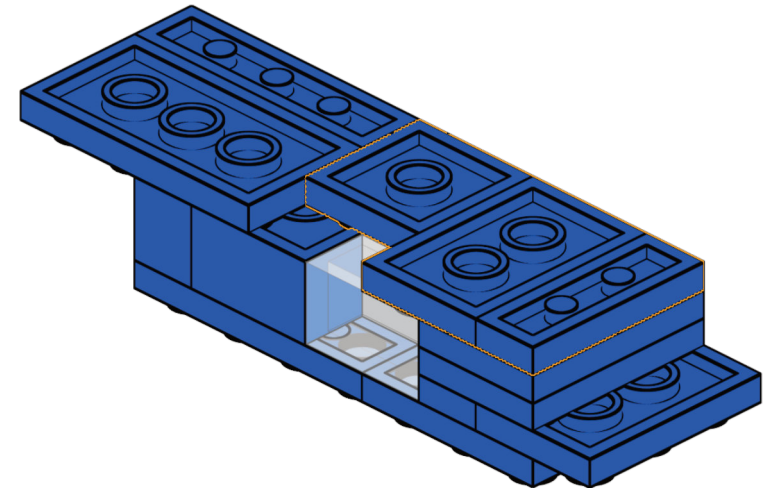
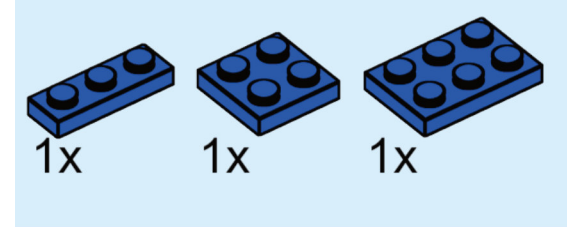

15

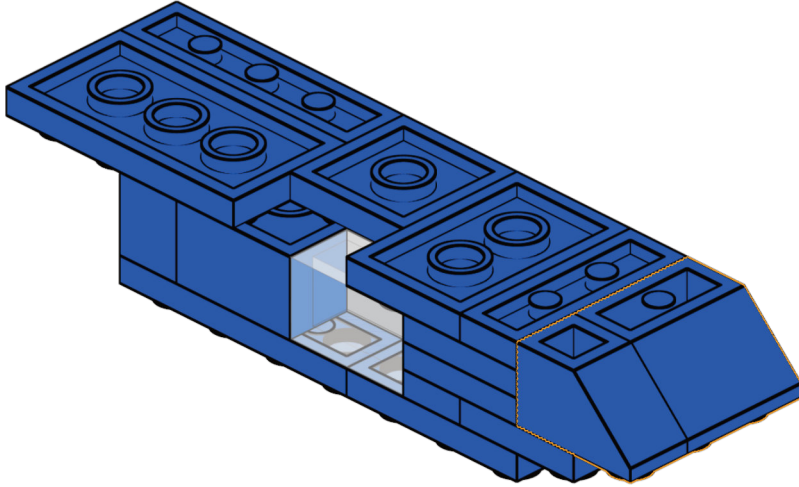
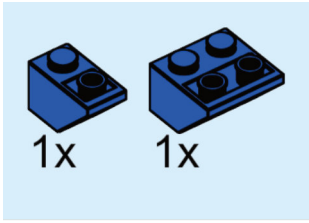

16

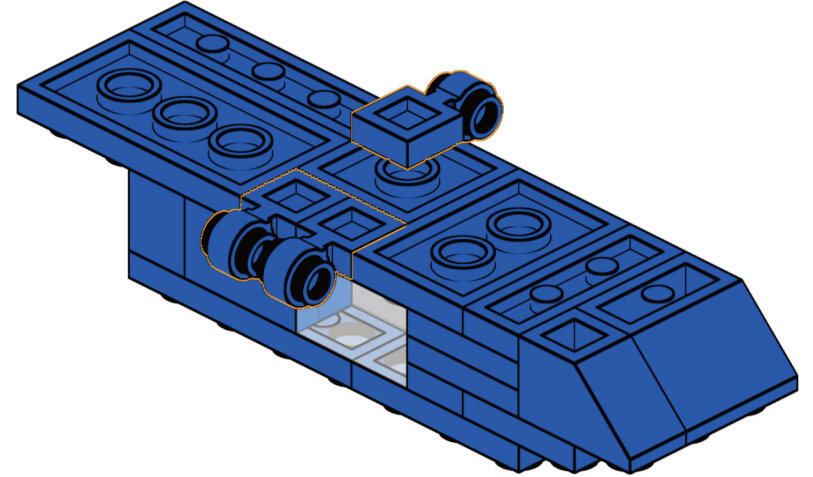
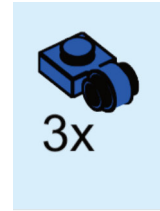

17

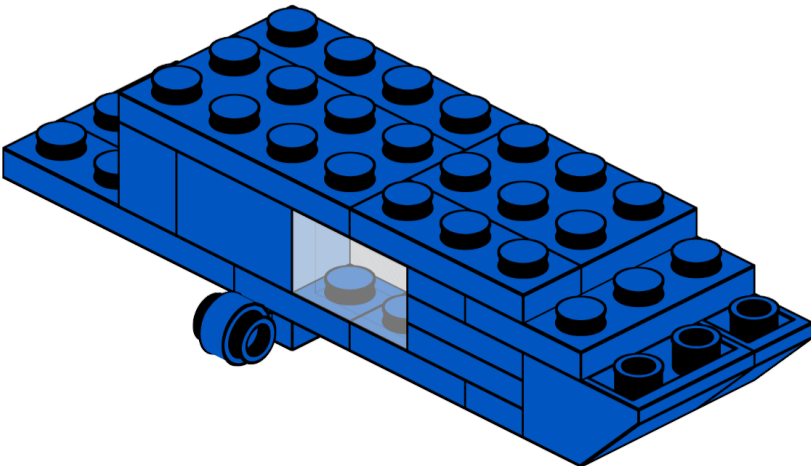

18

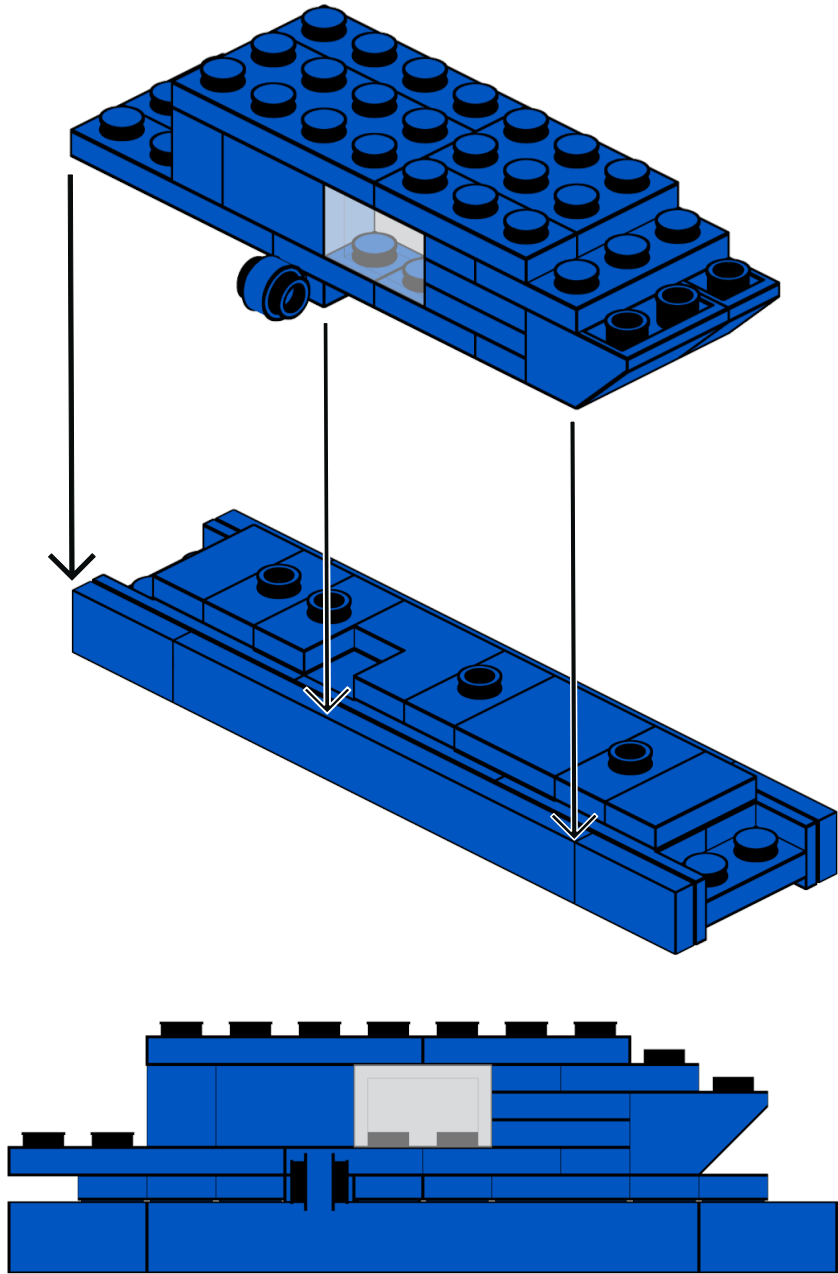

19

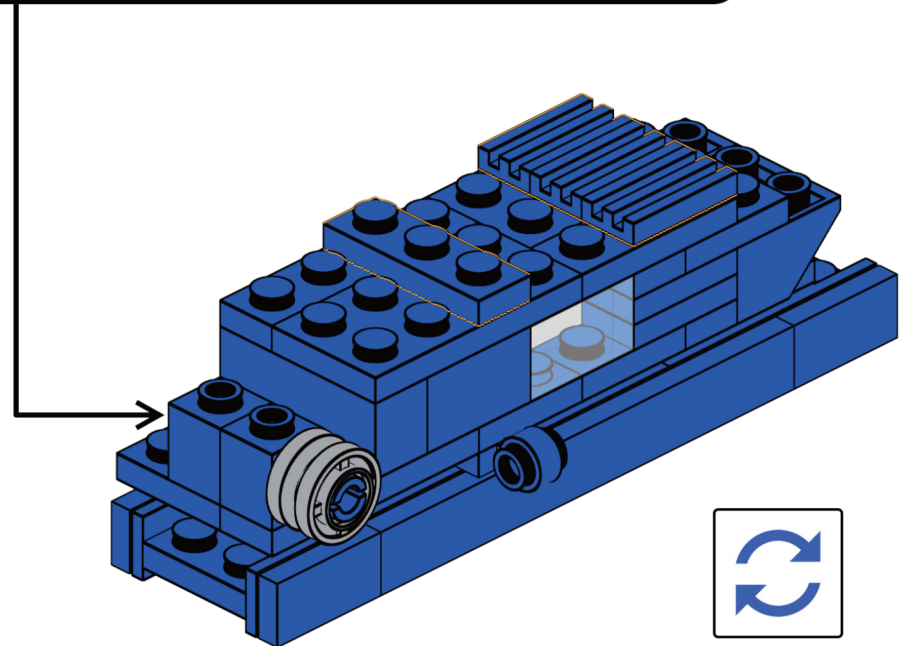
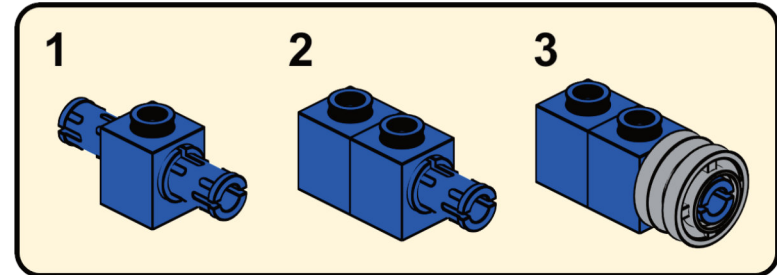
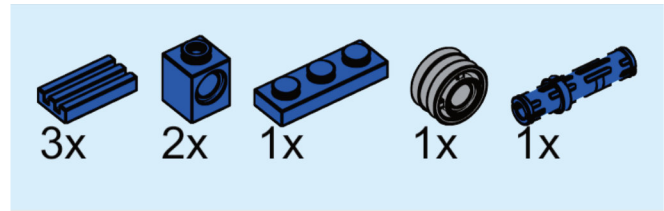

20

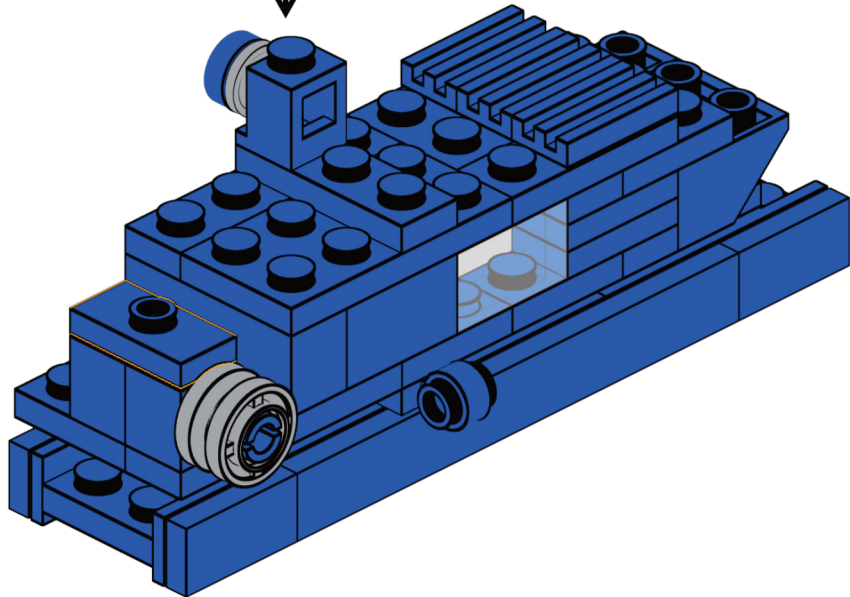
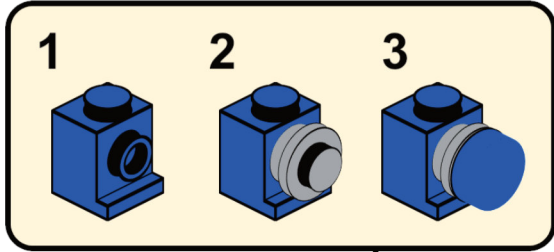
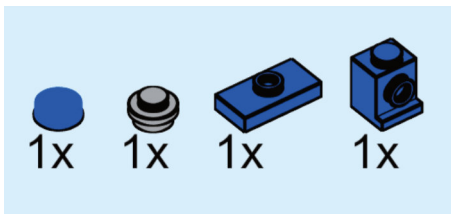

21

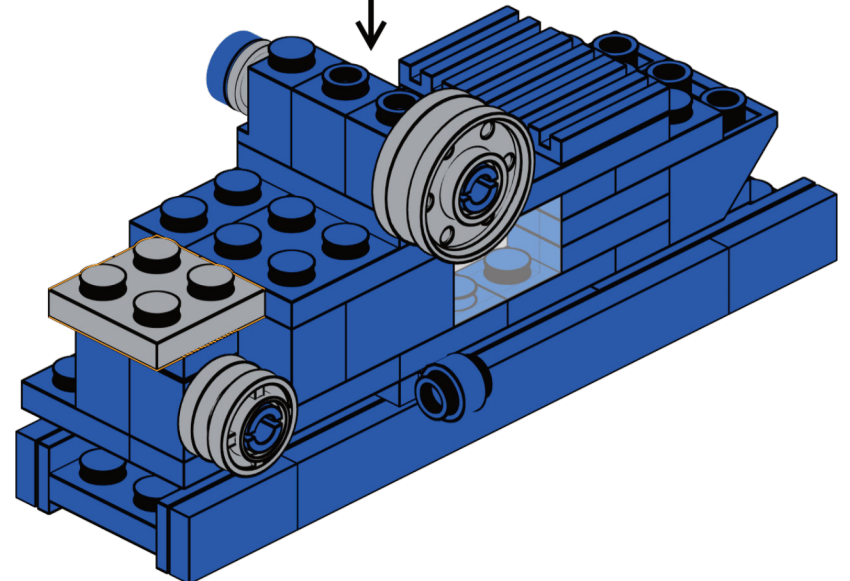
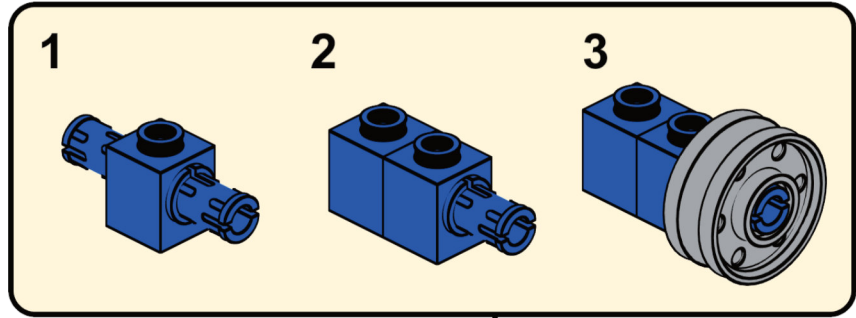
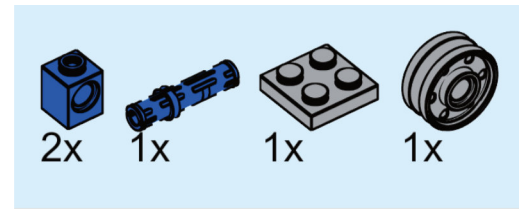

22

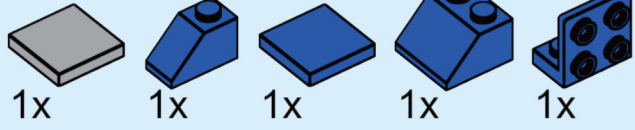

23

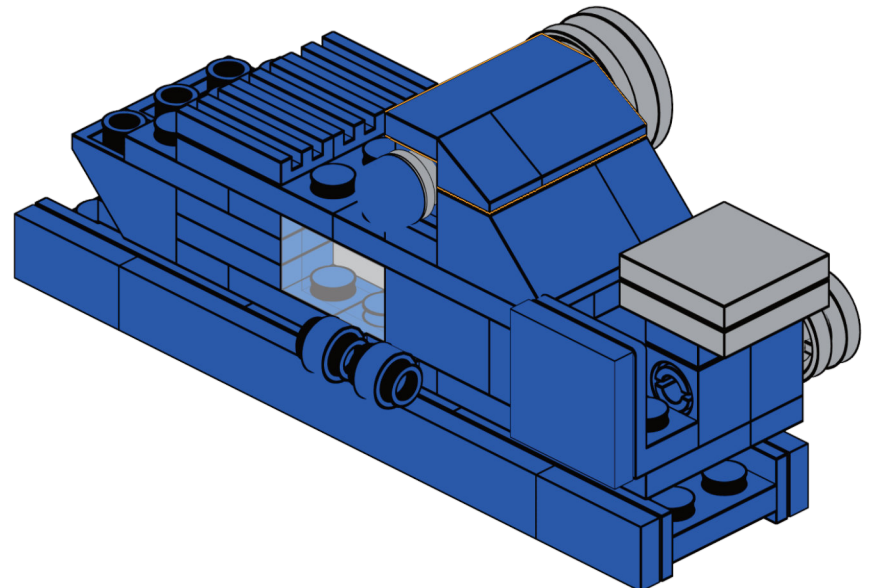
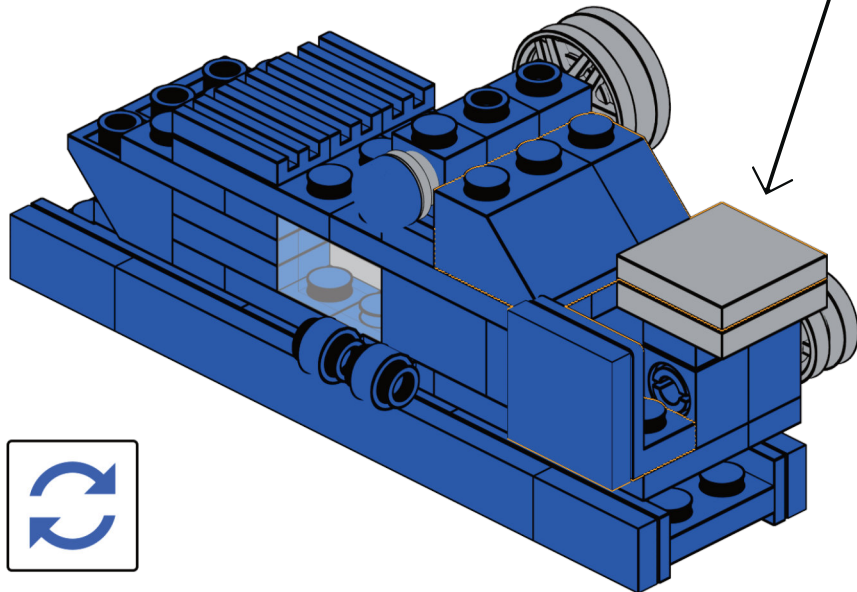
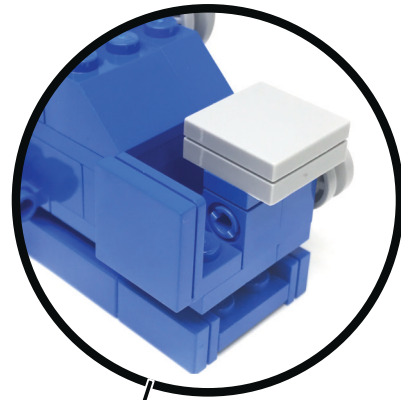
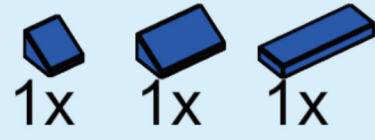

24

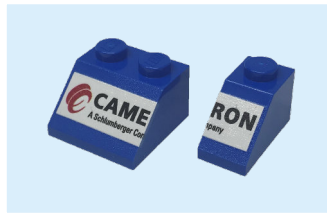

25

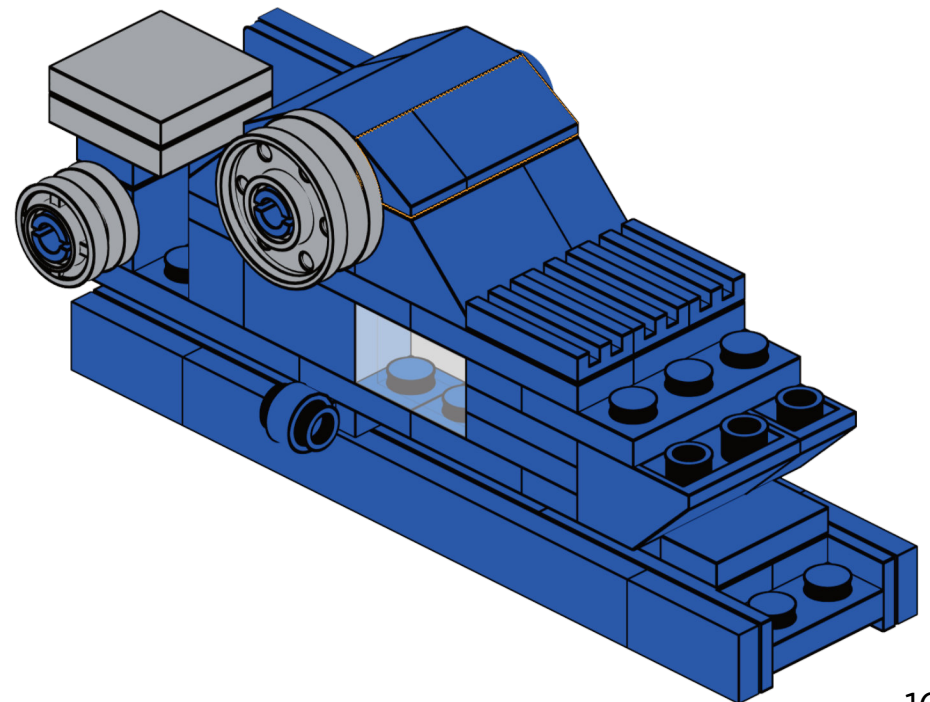
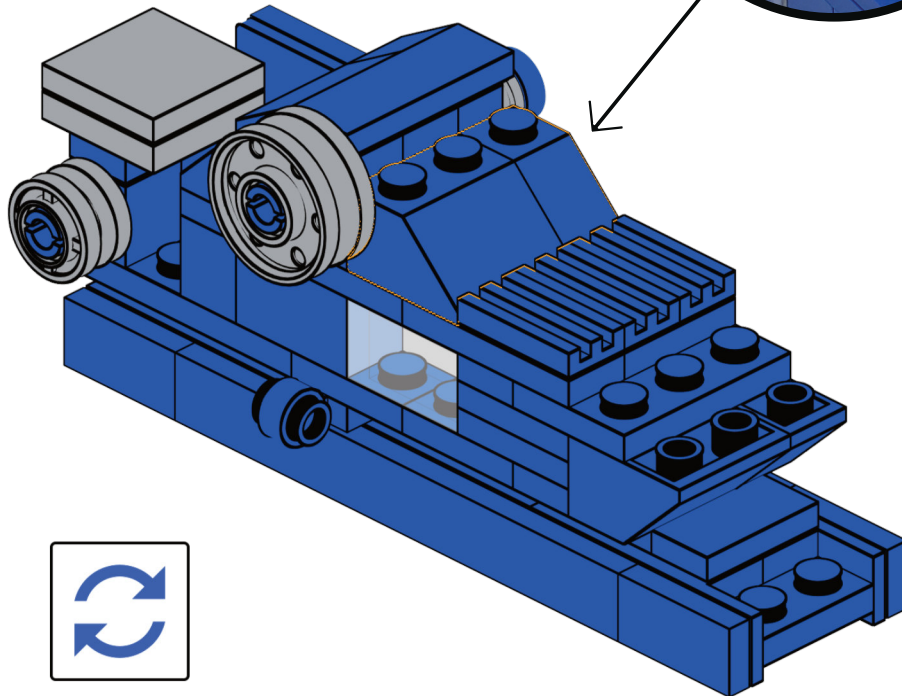
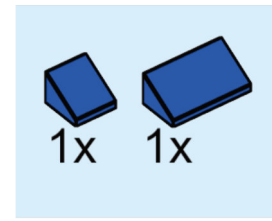

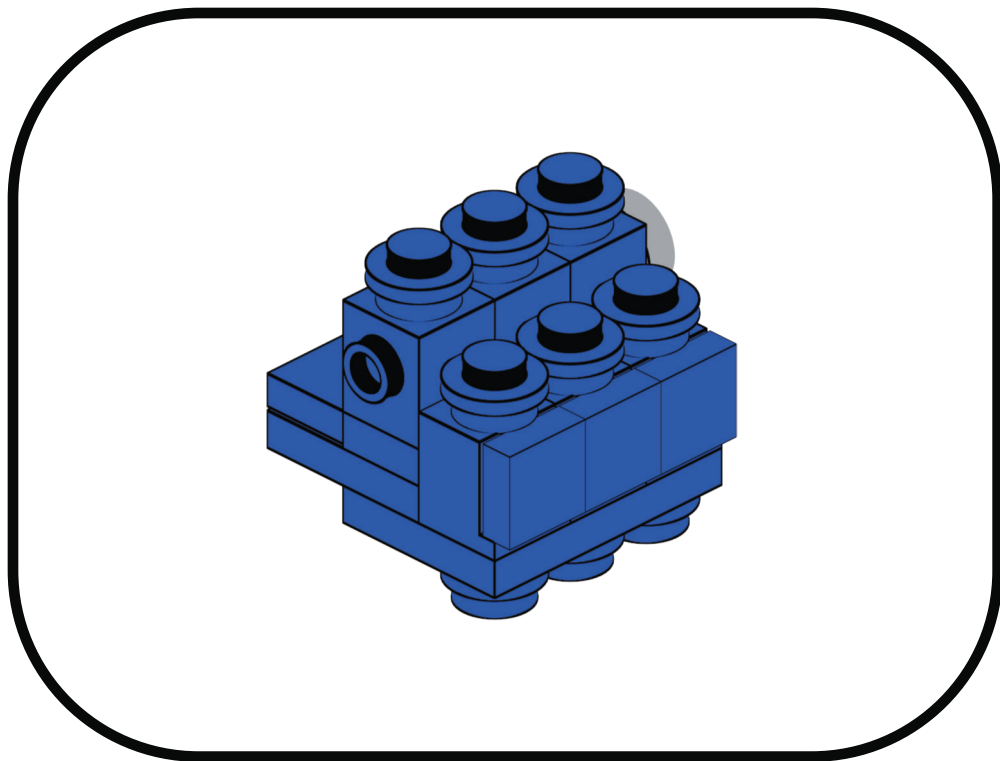

26

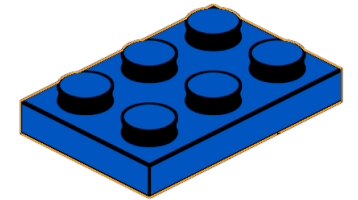
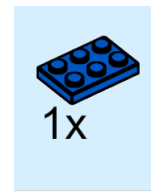

27

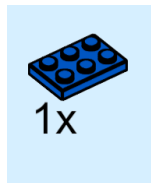

28

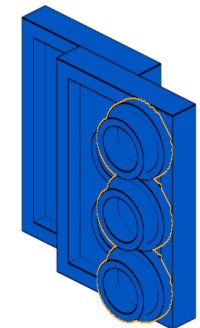
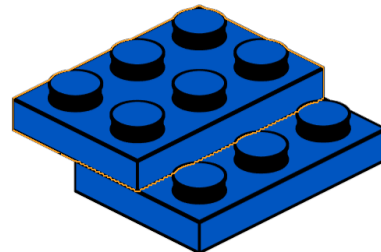
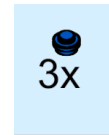

29

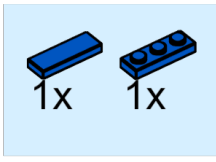

30

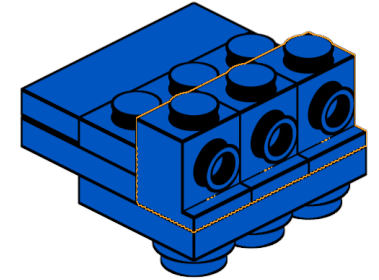
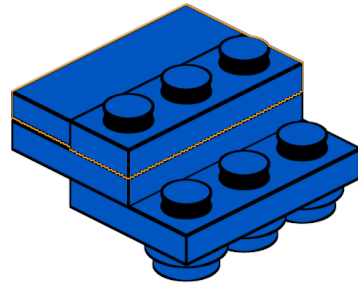

31



32

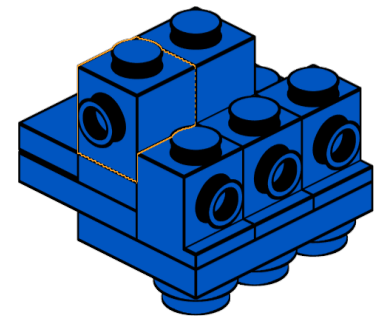
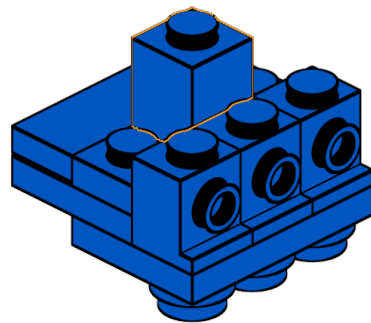

33



34

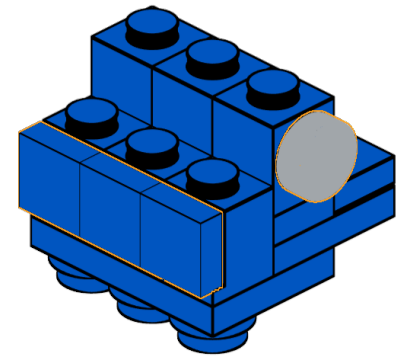
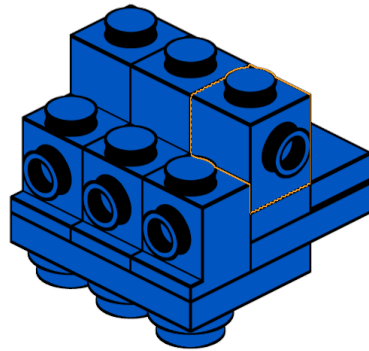
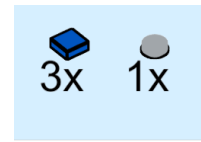

35



36

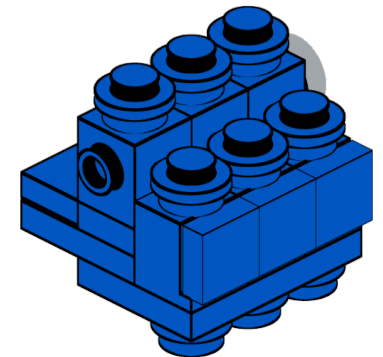
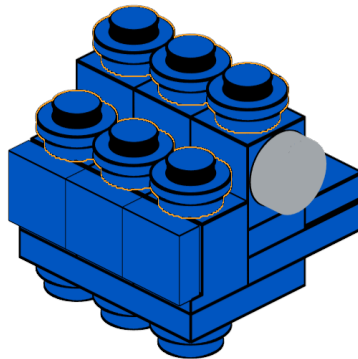

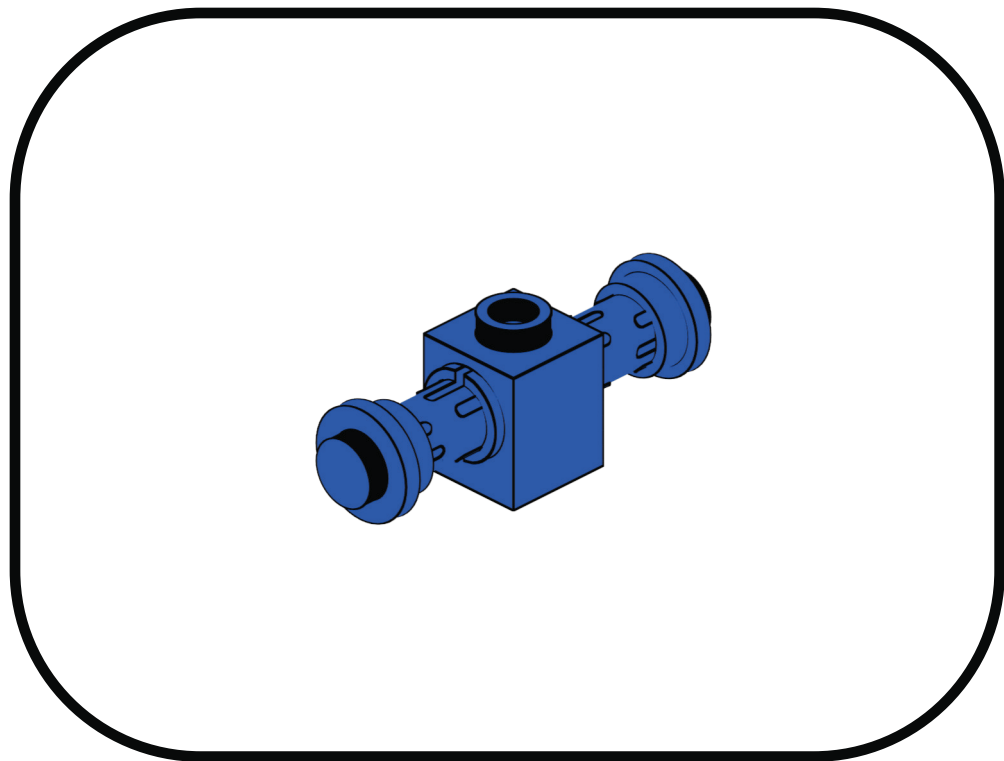

38

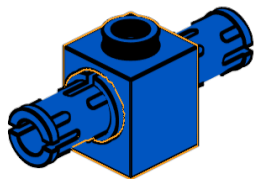

37

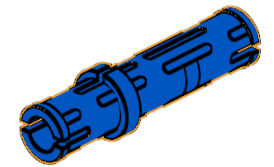
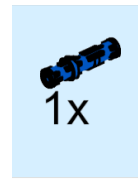

39

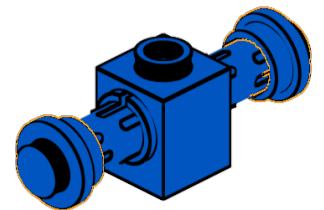

40

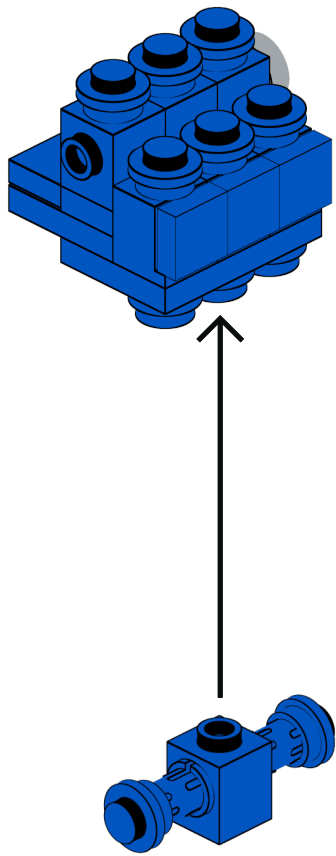

41

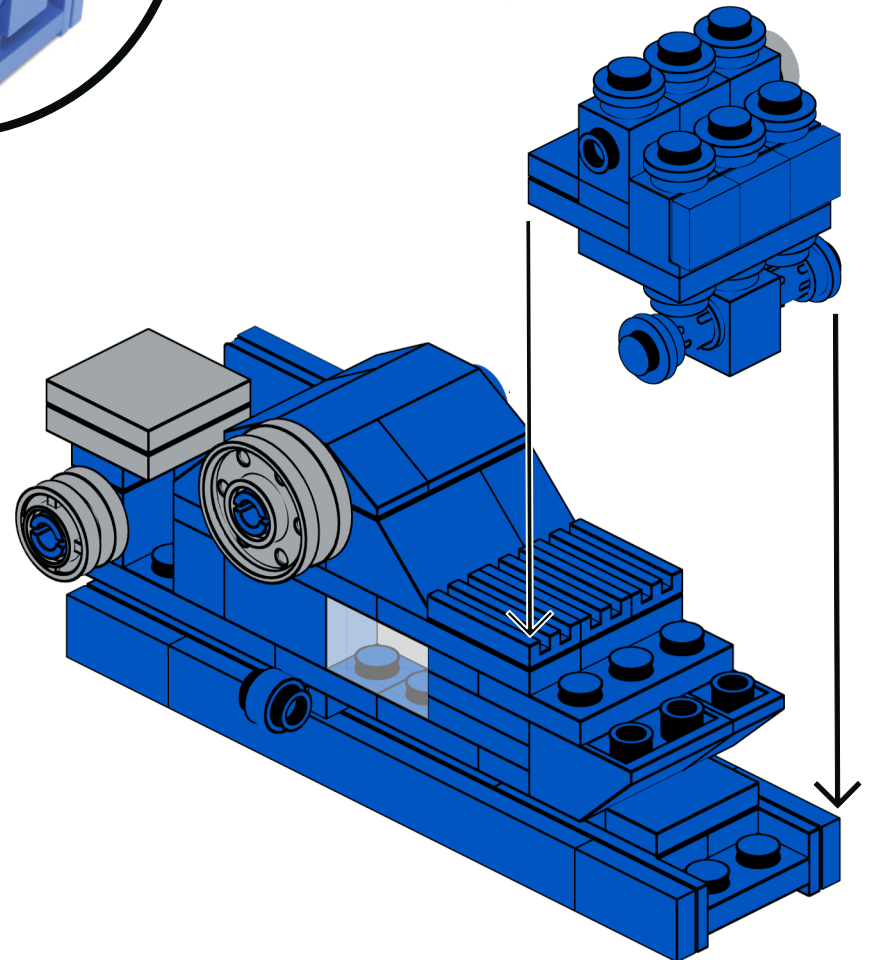
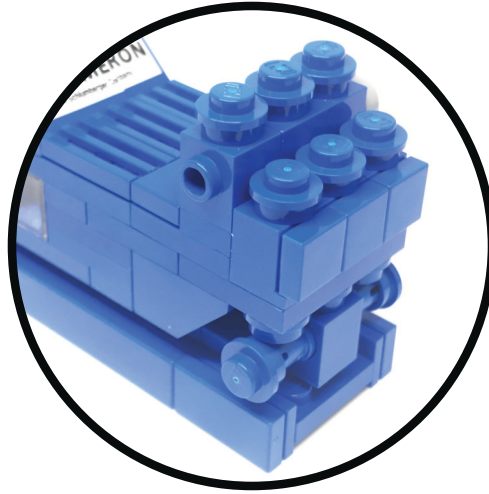

42

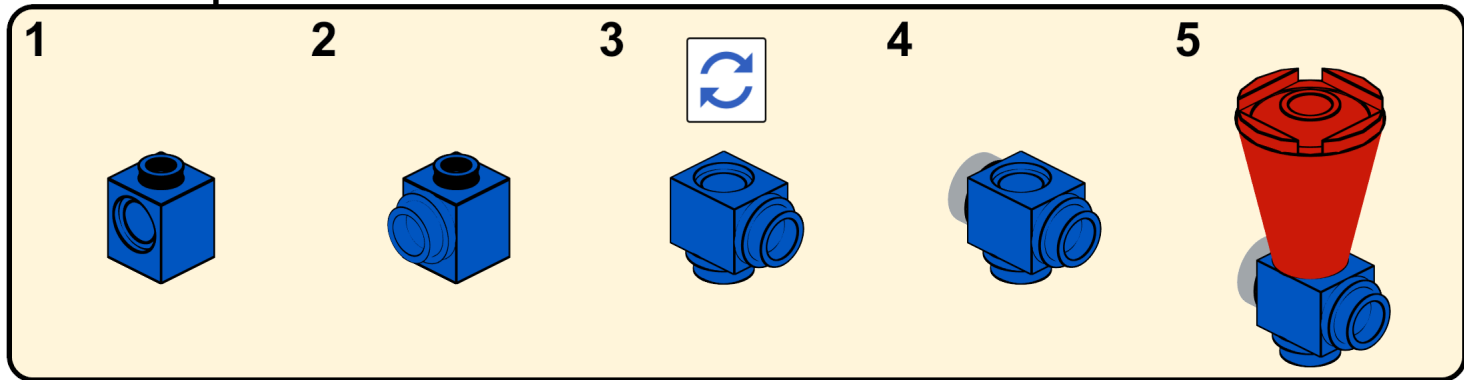
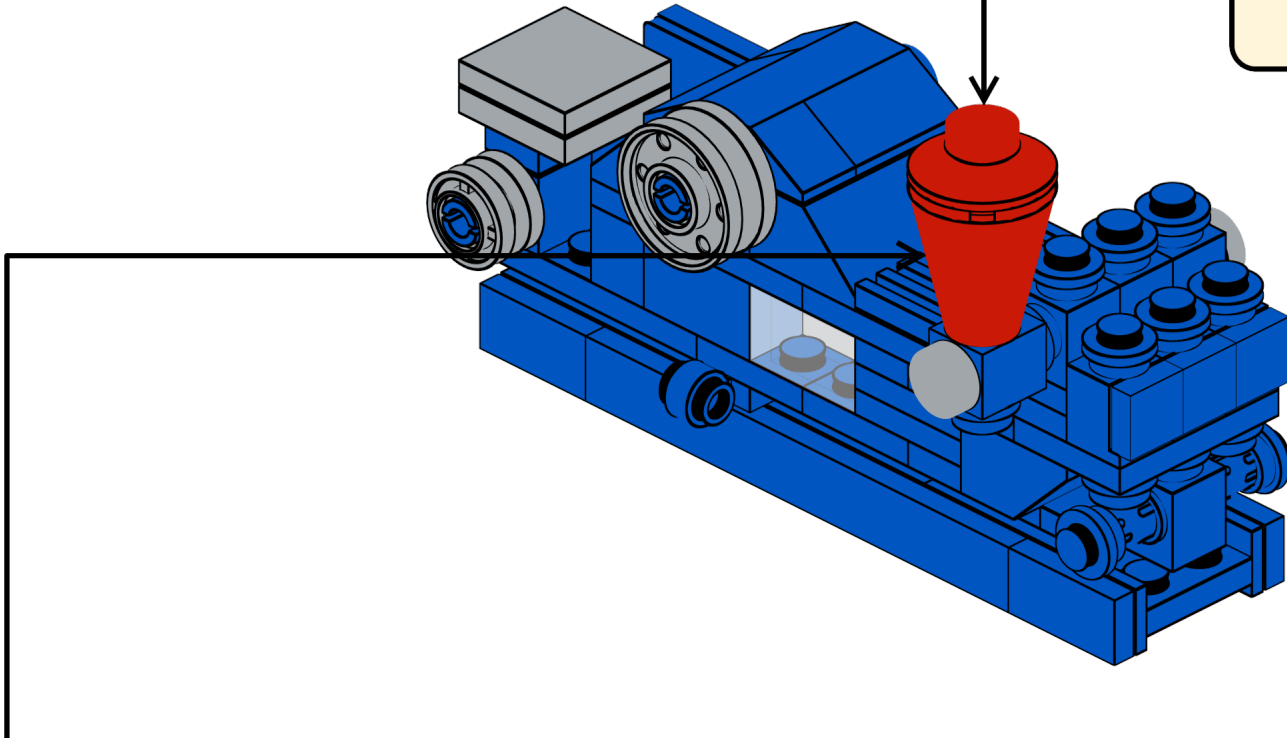
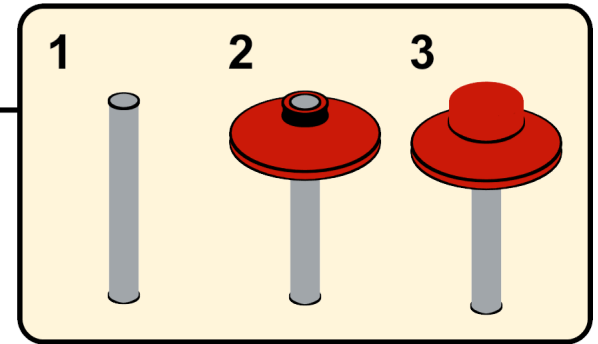
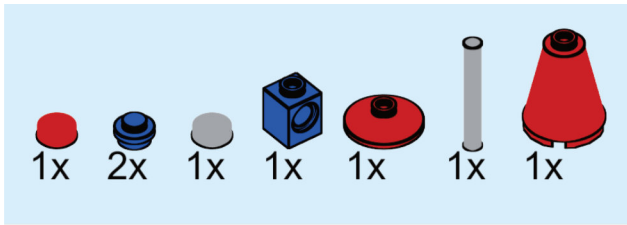

43

