

NIMAC
PACIFIC
By **ECOVLVE**

ED

Electric High-Tip Dumpers



KEY FEATURES

- ZERO EMISSIONS
- HYDRAULIC HIGH-TIP SKIP
- LOW NOISE LEVEL
- BUILT-IN CHARGING SYSTEM
- CUSTOMIZED RANGE OF ATTACHMENTS
- AWD OPTION
- PUNCTURELESS TYRES
- IDEAL TO WORK IN CONFINED SPACES

ED ELECTRIC DUMPERS



	ED800	ED1000	ED1500
CAPACITY			
Maximum Load Capacity	800 Kg	1000 Kg	1500 Kg
Heaped Capacity	480 L	600 L	800 L
Struck Capacity	350 L	435 L	575 L
Water Level Capacity	225 L	315 L	460 L
Unladen Weight	1200 Kg	1200 Kg	1500 Kg

DIMENSIONS			
MAX Total Height (A)	2610 mm	2610 mm	2610 mm
MAX Lifting Height	1630 mm	1630 mm	1790 mm
MAX Tipping Height (A2)	1470 mm	1470 mm	1600 mm
MIN Tipping Height	1120 mm	1120 mm	1120 mm
Ground Clearance	180 mm	180 mm	200 mm
Collapsed Height	1310 mm	1310 mm	1340 mm
Lenght with Driver's Platform Closed	2060 mm	2060 mm	2250 mm
Lenght with Driver's Platform Open	2390 mm	2390 mm	2580 mm
Driver's Platform lenght (B3)	340 mm	340 mm	340 mm
Wheelbase (B4)	1210 mm	1210 mm	1330 mm
Width (C1)	800 mm	990 mm	1160 mm
Track (C2)	590 mm	780 mm	970 mm

GROUND PRESSURE			
Unladen Front Wheels (D1/D3)	280 Kg	280 Kg	375 Kg
Laden Front Wheels (D1/D3)	650 Kg	650 Kg	1125 Kg
Unladen Rear Wheel	635 Kg	635 Kg	750 Kg
Laden Front Wheel	700 Kg	700 Kg	750 Kg

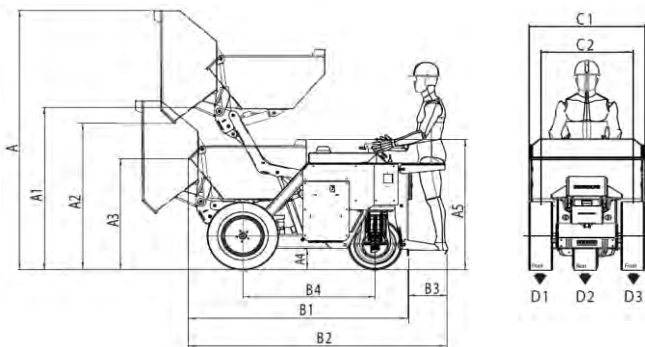

	ED800	ED1000	ED1500
DRIVE			
Drive type	1 Wheel Drive		3 Wheel Drive
Steering	Rear Wheel Steering, 90° Angle		
External Turning Radius	1600 mm		
MAX Speed	6 Km/h		8 Km/h
MAX Gradeability	15°		

TRANSMISSION			
Drive/Steering	Electric Proportional		
Front Tyres (Super Elastic)	27 x 8,5 x 15"		
Front Tyre (Super Elastic)	21 x 8 x 9"		

HYDRAULIC SYSTEM			
Gear Pump Flow Rate and Operating Pressure	5,5 l/min , 130 Bar		6,5 l/min, 150 Bar
Hydraulic Pump Motor	2,2 Kw		
Hydraulic Tank Capacity	2,8 L		5 L

ELECTRIC SYSTEM			
Voltage	24 V		
AGM Battery	9,6 Kwh		14,4 Kwh
Integrated Charging Input	100-240 Volts (AC)		
Integrated Charging Output	50Amp 24V (DC)		100A 24V (DC)
Recharge	8 Hrs		10 Hrs

DRIVE MOTOR			
Motor Type	Induction Motor		
MAX Power Output	5kw / 7Hp		5 + 4Kw / 11Hp

NOISE EMISSIONS			
Driving	65 dB		
Adjustable Buzzer	60 - 80 dB		

OPTIONS			
Removable Concrete Shoot			
Vacuum Dust Suppression System with Dust Collection Inside the Skip			
Operator Seat			
Tunnel Spec to work on Wet Environment			
No Mark Tyres			

