

# NIMAC PACIFIC

By  D'AVINO

# 120TW **Dump Truck Triple View**



## KEY FEATURES

- ENHANCED SAFETY AND STABILITY
- 180° SWIVEL ABRASION RESISTANT BODY
- 4WD HYDROSTATIC TRANSMISSION
- 3 MODE / 4 WHEELS STEERING
- MAXIMUM MANEUVERABILITY
- LEVEL II FOPS PROTECTION SYSTEM
- ENCLOSED AIR-CONDITIONED CABIN
- ROBUST AND RELIABLE

# 120TW DUMP TRUCK

MADE IN ITALY

**HARDOX**  
IN MY BODY

## PERFORMANCE

MODEL	120TW
Maximum Load Capacity	12000 Kg
SAE Heaped Capacity	6000 L
Struck Capacity	4900 L
Unladen Weight	7960 Kg
Body External Turning Radius (1)	5150 mm
Internal Wheels Turning Radius (2)	2475 mm
External Wheels Turning Radius (3)	4650 mm
MAX Driving Speed	35 Km/h
MAX Gradeability with Full load	40 %

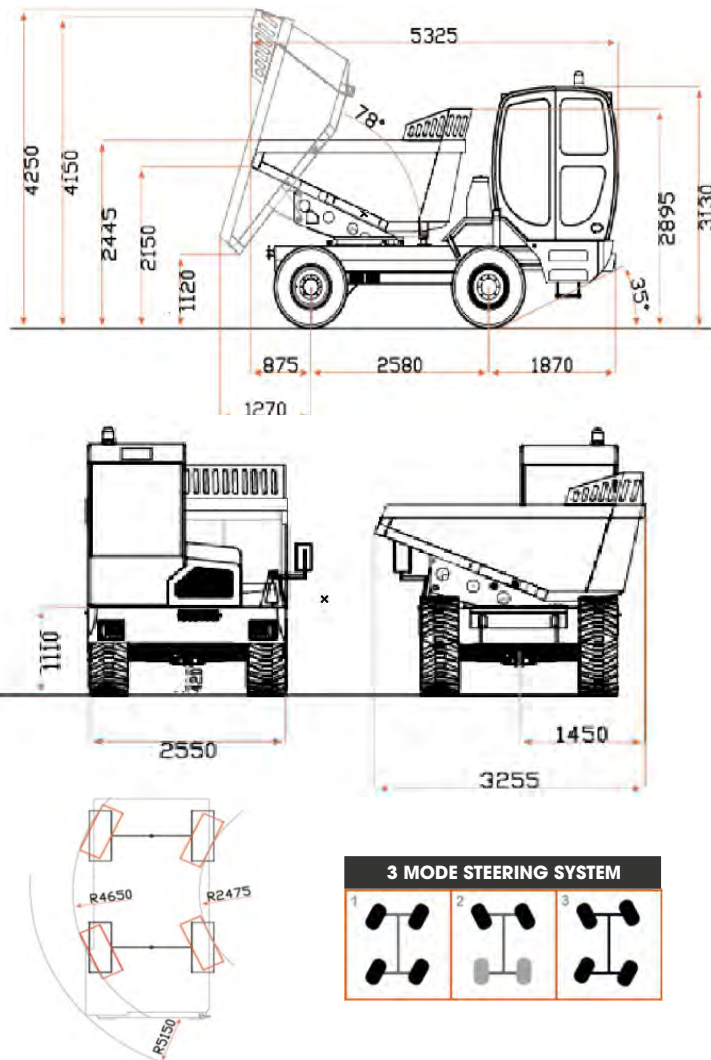

## STANDARD SPECIFICATIONS:

ENGINE	
Model	Perkins 1104 TA Tier IIIA
Engine Power	(83 Kw/113 Hp)
TRANSMISSION	
Type/Model	Automotive Hydrostatic Transmission
Front Axle	+ - 8° Oscillating Steering Axle
Rear Axle	Fixed Steering Axle with Flanged Gearbox
Diferential Locks	Front Automatic, Rear Hydraulically controlled
Maximum Travel Speed	35 Km/h
Gears	4 Forward and 4 Reverse, 2 Electro-Hydraulic HI - LO + 2 Speed Transmission
Inching Control	Standard
BRAKES	
Service Brakes	Multi-discs Hydraulic Service Brakes on Both Axles with Fail-Safe circuit
Parking Brake	Multi-discs Hydraulic Parking Brake with Automatic Activation
TYRES	
Standard Tyres	Trelleborg High Floation 500/60 R22.5
CABIN	
High-Visibility 3 Position swivel driving platform	Std
Enclosed Cabin, ROPS / FOPS II Approved Structure	Std
Automotive Air-Conditioning System	Std
HYDRAULIC SYSTEM	
Hydraulic Gear Service Pump for utilities	63 l/min
Hydraulic Gear Service Pump for Steering and Brakes	48 l/min
BODY	
Certified HARDOX 500 Abrasion Resistant Body Structure	Std
180° swivel body	Std
MISCELLANEOUS	
Fuel tank capacity	95 L
Hydraulic System capacity	140 L
Electrical system voltage	12v
AVAILABLE OPTIONS	
Deutz TCD 3.6L Tier IIIB Engine - DOC (90 Kw/121 Hp)	Optional
Perkins StageV Engine -DPF & SCR (90 Kw/121 Hp)	Optional
Low profile Agricultural tyres	Optional
Pneumatic Suspension Grammer Seat	Optional
360° Vision Cameras System	Optional
LED Work lights Kit	Optional
Rugged bars protection kit	Optional
Hydraulic auxiliary line with joystick control	Optional



Nimac Pacific reserves the right to modify and update the contents of this at any time. Information and technical data are as available at time of printing.

For further information visit [www.nimacpacific.com.au](http://www.nimacpacific.com.au)

**NIMAC**  
PACIFIC