

NIMAC PACIFIC

By  D'AVINO

DS70 ARTICULATED DUMPER



KEY FEATURES

- 180° SWIVEL ABRASION RESISTANT BODY
- ENHANCED STABILITY
- 4WD HYDROSTATIC TRANSMISSION
- FOLDABLE ROPS STRUCTURE
- COMPACT SIZE
- HIGH QUALITY COMPONENTS
- ROBUST AND RELIABLE

DS70 ARTICULATED DUMPER

MADE IN ITALY

HARDOX
IN MY BODY

PERFORMANCE

MODEL	DS70
Maximum Load Capacity	7000 Kg
SAE Heaped Capacity	3600 L
Struck Capacity	2800 L
Unladen Weight	3500 Kg
MAX Driving Speed	30 Km/h
MAX Gradeability with Full load	35%

STANDARD SPECIFICATIONS:

ENGINE	
Model	Yanmar Diesel Tier IIIA
Engine Power	(52,1 Kw/70,7 Hp)
TRANSMISSION	
Type/Model	Automotive Hydrostatic Transmission
Axles	Planetary reduction on differential output
Articulation/Swing	$\pm 31^\circ / \pm 15^\circ$
Gears	2 Forward and 2 Reverse
BRAKES	
Service and Parking Brakes	Oil-Immersed Multi-discs Hydraulically Operated
TYRES	
Standard Tyres	12.5/80-18"
DRIVING PLATFORM	
Grammer Deluxe seat	Std
Foldable ROPS Protection frame	Std
HYDRAULIC SYSTEM	
Double Hydraulic Gear Pump	14/16 cm ³
BODY	
Certified HARDOX 500 Abrasion Resistant Body Structure	Std
180° Swivel body, unloading on 3 sides	Std
MISCELLANEOUS	
Fuel tank capacity	78 L
Hydraulic tank capacity	90 L
Electrical system voltage	12v
AVAILABLE OPTIONS	
Yanmar TierV engine	Optional
Front View Camera System	Optional
LED Work lights Kit	Optional
Canopy	Optional

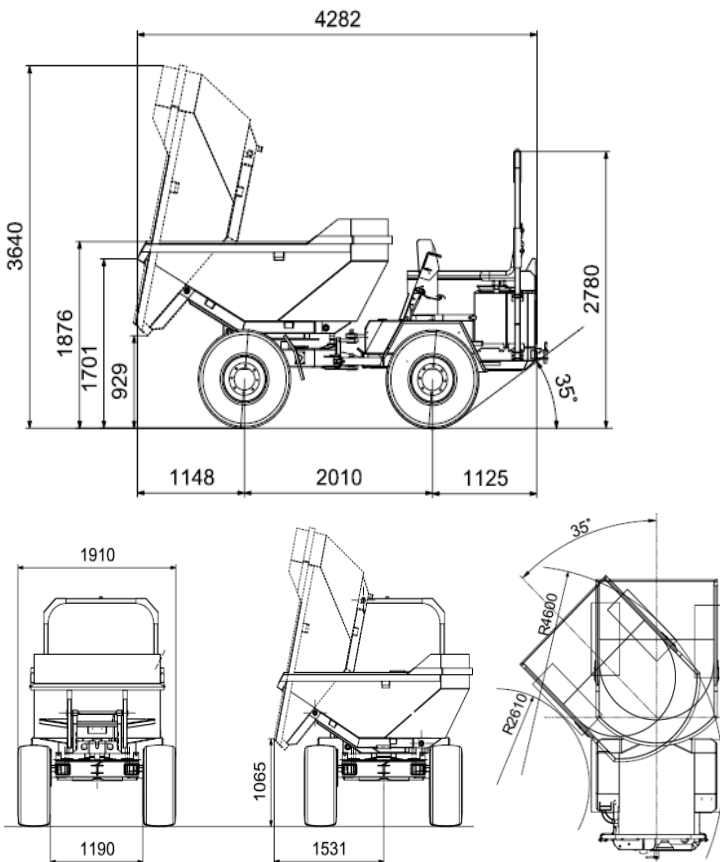

Nimac Pacific reserves the right to modify and update the contents of this at any time. Information and technical data are as available at time of printing.

For further information visit www.nimacpacific.com.au

NIMAC
PACIFIC