



WorkSafeWorkSmart.com™
Building Profits
Through Safety, Efficiency and Engagement

Catalog

Fall 2021

Work Smarter, Not Harder...

finding the most innovative and effective tools to help your business thrive in an ever-changing economy.



(469) 708-9797



info@worksafeworksmart.com



WorkSafeWorkSmart.com

5S LEAN WORKPLACE



1. SORT

Organization - keeping only what is necessary and discarding everything else - when in doubt, throw it out



2. SET IN ORDER

Orderliness - arranging and labeling all necessary items for easy use and return by anyone



3. SHINE

Cleanliness - keeping everything swept and clean for inspection - for safety and preventative maintenance



4. STANDARDIZE

Standardized cleanup - the state that exists when the first three pillars or "5's" are properly maintained



5. SUSTAIN

Sustaining the discipline - making a habit of properly maintaining correct procedures

"What gets measured gets done!"



Office: (469) 708-9797
Info@WorkSafeWorkSmart.com

The Vision

Working together to build a safer, more efficient, and more profitable lumber industry.

The Tools

Utilizing the tools and processes to enable your operation to reach it's highest potential.

The Team

Our team of innovative partners work to aid your operation in growth and development.

Find out how we can help you and your business today!

We strive to help business owners develop a solid foundation and business strategy so they can be even more successful.

We will work to improve sales, productivity, organization, company culture, and employee satisfaction through helping you build a lean culture in your company.



ABOUT US



Building Profits Through Increased Safety and Efficiency



For over 15 years, Lumber Buddy™ has been helping Building Materials Distribution Centers and Pro Dealer Lumber Yards work safer and work smarter. Our Lumber Buddy™ Portable Workstations are hard at work in 48 of the 50 states and all of the Canadian Provinces.

Working Safer and Working Smarter has been our focus since we began. It continues to be the driving force in our company. To that end, we are expanding our vision to a broader mission of offering not only Lumber Buddy™ productivity products, but also promoting the use of safety, productivity equipment, and services. Since September 1st of 2015, Lumber Buddy™ productivity products are offered by WorkSafeWorkSmart.com, LLC. Our focus is not only providing equipment but also on-site training and optimization consulting services.

WorkSafeWorkSmart.com, LLC is promoting LEAN optimization in our industry. With increasing pricing pressure, we feel LEAN is an excellent way to maintain margins, by decreasing costs through the elimination of waste. Doing more with less is what LEAN is all about.

Request A Quote: LumberBuddy.com



BEFORE YOU STAFF UP.. BUDDY UP!!!

Top 10 Advantages

Lumber Buddy™ System VS. New Hire

Lumber Buddy™ Portable Workstations can give you the additional production you need to keep up with work demands! By better equipping your existing staff, you avoid the hassle of hiring and the additional expenses of staffing up. Think of all you can gain in the long run from a more efficient system!

- 1 One Time Expense**
- 2 Eliminate the hassle of new hire paperwork / training.**
- 3 Ready to work on day one.**
- 4 No need for drug screening.**
- 5 Lumber Buddy™ won't call in sick or show up late.**
- 6 Lumber Buddy™ won't take vacation time.**
- 7 Lumber Buddy™ doesn't take smoke breaks.**
- 8 No Overtime Cost**
- 9 Won't spend time in idle conversations.**
- 10 Lumber Buddy™ can't file unemployment.**

Models and Features

All units are rated to hold a 10,000 lb load capacity.

General Production

Maximum fork thickness 2³/₄"
Maximum carriage width 84"

Features

LB9018N

Standard 7.5ft Portable Workstation.

- 18" - Platform Stacking Height
- 2 - 48" Drop-In Uprights
- 2 - 48" Combination Banding Channels
- 4 - Bolt on Replaceable Legs



The LB9018N Lumber Buddy™ Portable Productivity Platform is designed for use in all size locations. Its 7.5' base makes it ideal for working with both panel products, as well as all types of lumber and building materials. The 18" platform height is optimal for full unit production. The unit is equipped with 48" drop-in uprights that allow flat decking of materials, as well as fork splitting materials for increased efficiency. The unit's combination banding channels will enable you to attach all standard sizes of dunnage quickly.

LB9018NEXT

Standard 7.5ft Portable Workstation with extension wings.

- 18" - Platform Stacking Height
- 2 - 48" Drop-In Uprights
- 2 - 48" Combination Banding Channels
- 4 - Bolt on Replaceable Legs
- 2 - Wing Extensions w/ 48" Banding Channels
Expands to 10', 12', 14'



The LB9018NEXT unit enjoys all the features of LB9018N but also features extendable wings that can convert your 7.5' platform to a 10', 12' or 14' stacking base. The extensions enable you to handle composite products with ease.

YEAR ROUND SAVINGS... YEAR ROUND PRODUCTIVITY...

All units are rated to hold a 10,000 lb load capacity.

Large Unit Production

Maximum fork thickness 2¾"
Maximum carriage width 114"

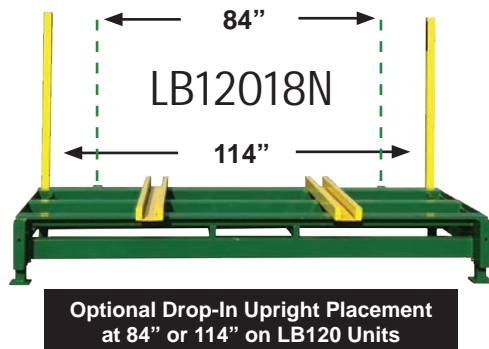

Features

LB12018N

Standard 10ft Portable Workstation.

- 18" - Platform Stacking Height
- 2 - 48" Drop-In Uprights
- 2 - 48" Combination Banding Channels
- 4 - Bolt on Replaceable Legs

The LB12018N Lumber Buddy™ Portable Productivity Platform is designed for use in all size locations. Its 10' base makes it ideal for working with panel products as well as all types of lumber and building materials. The 18" platform height is optimal for full unit production. The unit is equipped with 48" drop-in uprights that allow flat decking of materials as well as fork splitting materials for increased efficiency. The combination banding channels will enable you to attach all standard sizes of dunnage quickly.

LB12018NEXT

Standard 10ft Portable Workstation with extension wings.

- 18" - Platform Stacking Height
- 2 - 48" Drop-In Uprights
- 2 - 48" Combination Banding Channels
- 4 - Bolt on Replaceable Legs
- 2 - Wing Extensions w/ 48" Banding Channels
Expands to 12', 14', 16'

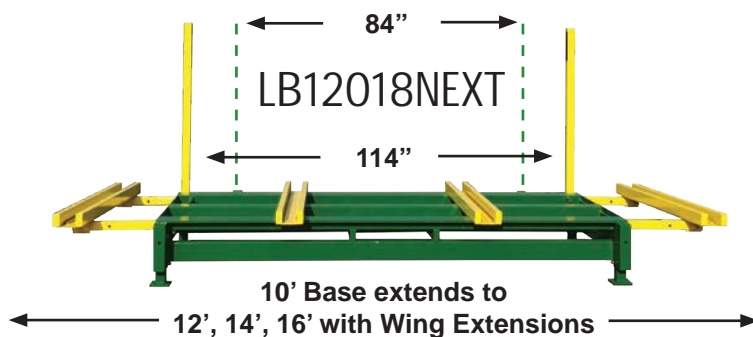

The LB12018NEXT unit enjoys all the features of LB12018N but also features extendable wings that can convert your 10' platform to a 12', 14' or 16' stacking base. The extensions enable you to handle composite products with ease.

Models and Features

The Best Unit Ever For Building Composite Deck and Siding Units

Introducing The NEW Lumber Buddy™ Composite Deck Rack

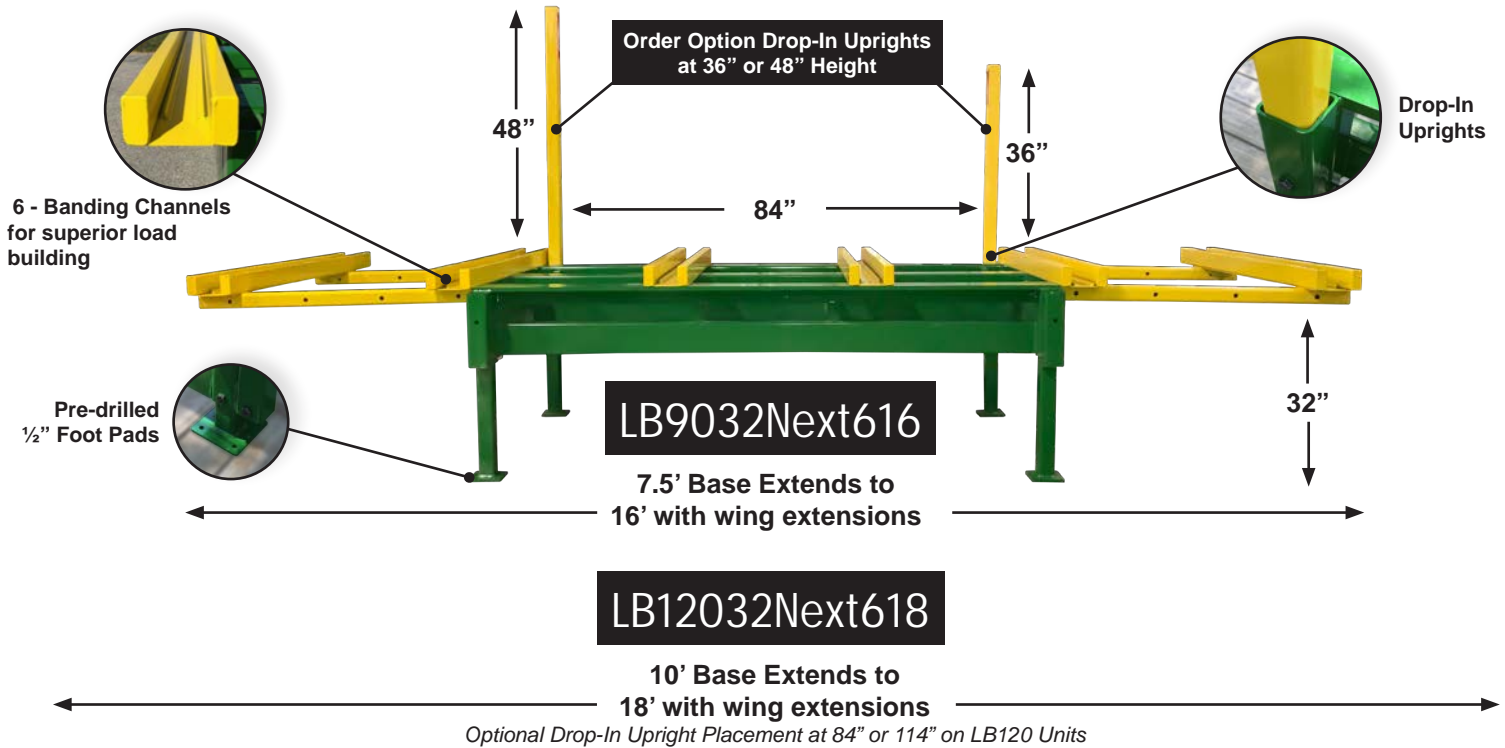

WorkSafeWorkSmart.com, LLC announces the introduction of their newest models: the **LB9032Next616** and **LB12032Next618**. This unit is specifically designed to improve efficiency when working with hard-to-handle composite products. From composite decking and trim boards to composite siding products, the **Next616 / Next618** units are time savers. The units' 32" platform height is ideal for building standard composite units. Its extra length gives support where needed, even for 20' unit lengths. This unit is equipped with 6 banding channels that accept the 3 most common sizes of dunnage materials: 1-1/2" grooved dunnage, 3x3 and 2x4. The unit is transportable, but also can be secured in place using the 4 holes in each foot pad.

LB9032Next616

- 7.5' - Base Unit
- 32" - Platform Stacking Height
- 2 - 36" or 48" Drop-In Uprights
- 6 - 48" Combination Banding Channels
- 4 - Bolt on Replaceable Legs
- 16' - Deck length for level support of 20' materials

LB12032Next618

- 10' - Base Unit
- 32" - Platform Stacking Height
- 2 - 36" or 48" Drop-In Uprights (*Placement at 84" or 114"*)
- 6 - 48" Combination Banding Channels
- 4 - Bolt on Replaceable Legs
- 18' - Deck length for level support of 20' materials

Recent surveys show on average customers gain 20 - 30% in productivity.

Product Features and Upcoming News Updates:

Replaceable Legs

Our replaceable leg components allow for a variety of platform stacking heights.

- 14.5" - double-ender unit
- 18" - standard full units production
- 18" - adjustable tilt leg
- 32" - 1/2 pack or composite materials

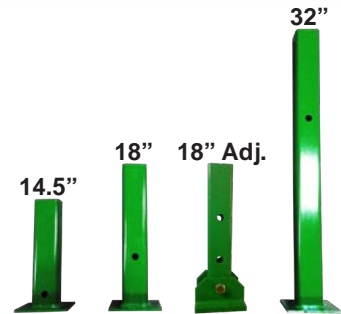

Coming Soon

Re-Designed EWP Units
and
Forklift Magnet Mounted & Lumber Buddy Mobile
Dispensers

Combo Banding Channels

The combo banding channels can accommodate 2x4, 3x3 and 1½" grooved dunnage.

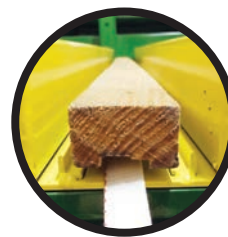

1½"



2x4



3x3

Models and Features

The Lumber Buddy™ component pieces are designed to be customizable to create equipment to Work Safe and Work Smart from our base unit LB9018N to the LB120DEN unit.

Your units can be configured to meet the needs of your operations.

For A Customized Quote - Call 888-844-4708



Lumber Buddy goes where the work is!

Additional Products

Call Today for Details 888-844-4708

LB17IJSS I-Joist Safety Stands

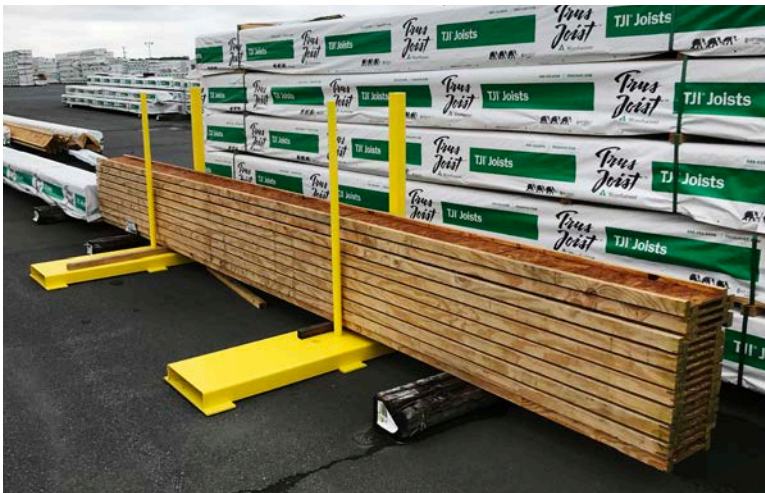

Features

- Heavy Duty Fabrication for years of service.
- 17" Base for stability and ease of use with all fork widths.
- Hi-Visibility Paint for increased safety.
- Safety Pole Placement for I-Joists up to 16" wide.

Benefits

- Increased Safety
- Increased Productivity
- Reduced Damage to Product
- Easy Clean Up
- Product Organized Neatly

WorkSafeWorkSmart.com, LLC is always looking for better ideas to improve efficiency and safety of the material handling process for our industry.

If you have an idea on how to work safer and smarter, let us help you share it with our industry. Call 888-844-4708 to discuss our product development process.

You can also email ideas@WorkSafeWorkSmart.com

Lumber Buddy Parts List

Uprights

36LDUR

Light Duty Drop-In Upright Tube
36" Exposed Height

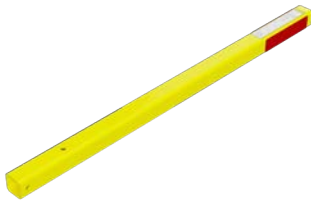

48SUR

Standard Drop-In Upright Tube
48" Exposed Height

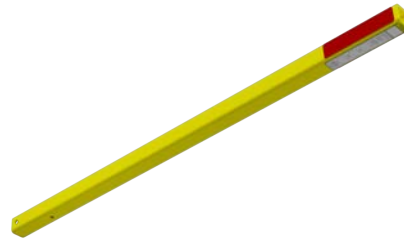

Banding Channels

BC-48

48" Banding Channel for Standard Bundles



BC-54

54" Banding Channel for Wide Bundles



Legs

L18PH-ADJ

Adjustable Tilt Leg
18" Platform Height
For use with vertical stacking of I-Joist



L18PH

Standard Leg
18" Platform Height



L32PH

Standard Leg
32" Platform Height
1/2 pack or composite materials



Are you needing a replacement or additional parts?

Wing Extensions

WT-G2EXT

Wing Insert Tube (G2-17)
for 48" and 54" Banding Channels

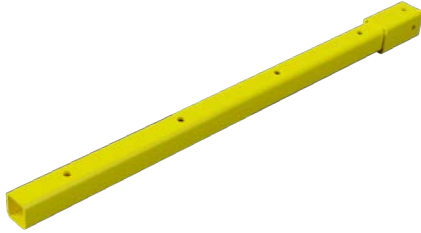

WT-6FTEXT

6 FT Wing Insert Tube
for 48" and 54" Banding Channels



Double-Ender

DEN-CL

Connector Leg
For Double-Ender Unit



DEN-CT

Connector Tube
For Double-Ender Unit



DEN-L14.5PH

Single LB Leg
14.5" Platform Height
Double-Ender Unit



Top 5 Reasons Companies Choose Lumber Buddy™

Produced and Marketed by WorkSafeWorkSmart.com, LLC

Lumber Buddy™ is more than just a seller of equipment. We are dedicated to helping you grow your business efficiently, safely and profitably. Working Safer and Working Smarter...than ever before!

#1 Proven Performance

For over 15 years, large and small companies in 48 of the 50 states and all across Canada trust Lumber Buddy™ to help them work safer and work smarter.

#2 Return on Investment (ROI)

The Lumber Buddy™ Portable Workstation is built to last! Many of our original Lumber Buddy™ Platforms are still in service after 15 years of hard work. That is a great ROI!

#3 Increased Productivity

In a survey of our customers from 2000 to today, customers reported that they felt their productivity increase with Lumber Buddy™ Portable Workstations was over 40% on average.

#4 Cost Savings

Lumber Buddy™ Portable Workstations help customers reduce cost by reducing the amount of time it takes to build their delivery packages, reduce manual handling, reduce on and off forklifts, time which results in substantial cost savings for you. Time really is money!

#5 Improved Safety

The Lumber Buddy™ Portable Workstations improve safety in the workplace by greatly reducing the amount of manual labor needed to produce a load. It also provides a more ergonomic environment when hand pulling is necessary which reduces injuries.



Building Profits Through Safety, Efficiency and Engagement.

Lumber Buddy™ Productivity Products are proudly produced and distributed by WorkSafeWorkSmart.com, LLC

Made in America

See the full story at



The 8 Wastes of Lean



DEFECTS

Efforts caused by rework, scrap, and incorrect information.



OVERPRODUCTION

Production that is more than needed or before it is needed.



WAITING

Wasted time waiting for the next step in a process.



NON-UTILIZED TALENT

Underutilizing people's talents, skills, and knowledge.



TRANSPORTATION

Unnecessary movements of information, production and materials.



INVENTORY

Excess information, products and materials not being processed.



MOTION

Unnecessary movements by people (e.g. walking).



EXTRA-PROCESSING

More work or higher quality than is required by the customer.

Is the use of Steel Banding Stealing Money from your Bottom Line?



Tiedowns & Strapping

Although steel banding has been used widely in the Truss and Wall Panel Industry for decades, it is no longer your only or best choice.

BOSS Strapping, either woven or composite provides you with the opportunity to use a safer, stronger, more versatile strapping solution.

Stable Pricing
Flexible Product Solutions
Cost Effective Tooling
Lean Efficiency

Call to find out more (936) 867-4801
BOSS-Strapping.com
orders@boss-strapping.com

Scan  Watch
Now  Video



Best Overall Strapping System



Stop Injuries - The removal of steel can be very dangerous. Keeping your workers safe is critical!



Unlike steel banding, polyester woven strapping can accommodate shifting weight.



Reduce the amount of damaged products and switch to polyester strap.



Scan Now



Video

National Contacts:

Mike Kontz
(810) 844-4578

Jeff Tweten
(417) 661-4386

Woven Polyester Strapping

Contact us for custom strapping.
Buckles recommended are based on normal usage.

Item Description	Item #	Tensile Strength	L/F per Coil	Packaging	Buckle Size
 5/8" Oscillated Wound	1500-58	1,500 lbs	2000	2 coils per box 27 boxes per pallet	16mm
 3/4" Oscillated Wound	1800-34	1,800 lbs	1650	2 coils per box 27 boxes per pallet	19mm
 3/4" Oscillated Wound	2400-34	2,400 lbs	1650	2 coils per box 27 boxes per pallet	19mm
 3/4" Oscillated Wound	2700-34	2,700 lbs	1650	2 coils per box 27 boxes per pallet	19mm
 3/4" Oscillated Wound	2950-34	2,950 lbs	1650	2 coils per box 27 boxes per pallet	19mm
 1 1/4" Ribbon Wound	3285-660-114	3,285 lbs	660	4 coils per box 12 boxes per pallet	25mm
 1 1/4" Ribbon Wound	3900-6-114	3,900 lbs	600	4 coils per box 12 boxes per pallet	25mm
 1 1/4" Oscillated Wound	3900-114 OS	3,900 lbs	1100	2 coils per box 27 boxes per pallet	25mm
 1 1/2" Ribbon Wound	5400-6-112	5,400 lbs	600	4 coils per box 12 boxes per pallet	32mm
 1 1/2" Oscillated Wound	5400-8-112 OS	5,400 lbs	800	2 coils per box 27 boxes per pallet	32mm

Item Description	Item #	MM	Qty
16mm (5/8") 0.147 Phosphate Coated Buckle	BUC58	16mm	1000 per carton
19mm (3/4") 0.159 Phosphate Coated Buckle	BUC34	19mm	1000 per carton
19mm (3/4") 0.170 Heavy Duty Phosphate Coated Buckle	BUC34HD	19mm	1000 per carton
25mm (1" - 1 1/4") 0.192 Phosphate Coated Buckle	BUC114	25mm	500 per carton
32mm (1 1/2") 0.272 Phosphate Coated Buckle	BUC112	32mm	250 per carton



Unlike many competitors, only top quality materials are used in BOSS Strapping, assuring the best quality and safest product possible. From production to packaging, you can count on BOSS for Quality and Convenience.

www.BOSS-Strapping.com

BOSS™ Starter Kit

Item # *StrKit*

- 1 - 250' Short Coil 3/4 2700 Strap
- 50 - 19mm Phosphate Coated Buckles
- 1 - 150' Short Coil 1-1/2 5400 Strap
- 20 - 32mm Phosphate Coated Buckles
- 1 - MT-1 Manual Tool
- 1 - Flexible Pallet Feeder
- 1 - Klever Kutter Cutting Tool



BOSS™ Forklift Starter Kit

Item # *34FSK*

- Forklift Mounted Dispenser
- 1 - 1650' Coil 3/4 2700 Strap
- 250 - 19mm Phosphate Coated Buckles
- 1 - MT-1 Manual Tool
- 1 - Flexible Pallet Feeder
- 1 - Klever Kutter Cutting Tool



BOSS™ Driver Kit

Item # *DrKit3/4*

- BOSS™ Duffle Bag
- 1 - 250' Short Coil 3/4 2400 Orange Strap
- 50 - 19mm Phosphate Coated Buckles
- 1 - MT-1 Manual Tool
- 1 - Flexible Pallet Feeder
- 1 - Klever Kutter Cutting Tool



Composite Strapping

NEW PRODUCT LINE

Item Description	Item #	Linear Strength	System Strength	L/F per Coil
5/8" Composite Strap	BC55	1190	2023	2000
5/8" Printed Composite Strap	BC55P	1190	2023	2000
3/4" Composite Strap	BC65	1322	2247	1640
3/4" Printed Composite Strap	BC65P	1322	2247	1640
1" Composite Strap	BC85	1763	3145	1640
1" Printed Composite Strap	BC85P	1763	3145	1640
1" Composite Strap	BC86	2314	3934	1476
1" Printed Composite Strap	BC86P	2314	3934	1476
1 1/4" FLEX Composite Strap	BC105F	3637	6035	770
1 1/4" FLEX Printed Composite Strap	BC105FP	3637	6035	770

Printed means BOSS Strapping printed on strap

FLEX indicates flexible coating - better in colder temps

Item Description	Item #	MM	Qty
16mm (5/8") Galvanized Buckle	BUC58G	16mm	1000
19mm (3/4") Galvanized Buckle	BUC34G	19mm	1000
25mm (1") Galvanized Buckle	BUC1G	25mm	500
32mm (1 1/4") Galvanized Buckle	BUC114G	32mm	250

5/8" Composite 16mm Buckles

3/4" Composite 19mm Buckles

1" Composite 25mm Buckles

1-1/4" Composite 32mm Buckles



Visit Us Online To Learn More About Our Product Lines BOSS-Strapping.com

Tools for Woven & Composite Strap

*90 day limited warranty for factory defects only

**Manufacturer's Limited Lifetime Guarantee



MT- 1 Manual Tool

Item # MT-1

This solid steel tool works with ALL sizes of strap up to 1-1/2".



***H-22**

Item # H22

Regular duty strapping tensioner for polyester cord strap up to 3/4".



***H-23**

Item # H23

Regular duty strapping tensioner for P.E.T. strap up to 3/4".



***H-25**

Item # H25

Heavy duty strapping tensioner for polyester cord strap up to 1".



***H-26**

Item # H26

Heavy duty strapping tensioner for polyester cord strap up to 1-1/2".



***H-27**

Item # H27

Heavy duty strapping tensioner for polyester cord strap up to 2".



***MUL-325**

Item # MUL325

Heavy duty strapping tensioner with special features for ease of use up to 3/4".



***MUL-375**

Item # MUL375

Extra heavy duty cord tensioner that cuts all cord types 3/4" to 1-1/2".



MUL-395

Item # MUL395

Only manual lashing tensioner on the market capable of pulling over 2,000 lbs of tension 1-1/2" to 2" with cutter.



****HFT-34**

Item # HFT34

This tool gives you the power, durability, and flexibility you need to handle all your strapping needs including round bundles up to 3/4".



Big BOSS

Item # BigBOSS

Extra heavy duty strapping tool (without a cutter) use on 1-1/4" - 1-1/2". Very Strong Tool.



Klever Cutter

Item # KK

Safety Cutter that works great on strap and boxes. Prevents accidental cuts.

Ask about our BOSS ProPack™ Program!



BOSS ProPack™ Woven

- 16 Coils of Strapping
- 2 Boxes of Buckles
- 1 MT-1 Manual Tool
- 1 Pallet Feeder
- 1 Klever Cutter

Item #	Break Strength	Size
ProPac 58	1500# Break	5/8"
ProPac 18	1800# Break	3/4"
ProPac 24	2400# Break	3/4"
ProPac 27	2700# Break	3/4"
ProPac 30	3000# Break	3/4"
ProPac 1-1/4	3900# Break	1-1/4"
ProPac 1-1/2	5400# Break	1-1/2"



BOSS ProPack™ Composite

- 16 Coils of Strapping
- 2 Boxes of Buckles
- 1 H-23 Ratchet*
- 1 MT-1 Manual Tool**
- 1 Pallet Feeder
- 1 Klever Cutter

Item #	System Strength	Size
ProPac 58C*	2023# Break	5/8"
ProPac 34C*	2247# Break	3/4"
ProPac 131C*	3145# Break	3/4"
ProPac 139C**	3934# Break	1"
ProPac 114C**	6035# Break	1-1/4"

COMPETITIVE FOR FULL STEEL PALLET BUYERS



Pallet Feeder

Item # *FDRTOOL*

This tool makes feeding strap through pallets and under bundles a much faster process.



DISPENSERS FOR WOVEN & COMPOSITE STRAP

Portable Dispenser

**Item # *PD34-3 Woven*
*PD34-8 Composite***

Great for Truss Bundling and Remote Location usage! Use with strap sizes up to 1½" wide.

For use with oscillated wound coils.
AVAILABLE FOR WOVEN OR COMPOSITE STRAP



Two-Wheeled Dispenser

**Item # *WD-3 Woven*
*WD-8 Composite***

Great for Conventional Banding Stations! Use with strap sizes up to 1½" wide.

For use with oscillated wound coils.
AVAILABLE FOR WOVEN OR COMPOSITE STRAP



Forklift Mounted Dispenser

**Item # *FLD-3 Woven*
*FLD-8 Composite***

Saves time and money. Great for Lean Process point of use storage! Use with strap sizes up to 1½" wide.

For use with oscillated wound coils.
AVAILABLE FOR WOVEN OR COMPOSITE STRAP





Phone: (936) 867-4801

Fax: (866) 702-4802

info@boss-strapping.com

www.boss-strapping.com

Scan Now



Visit Website

Single Use: Wall Panel Lifting Loops

RATED & IMPRINTED FOR LIFTING



WALL PANEL LIFTING LOOP *Working Load Limit Vertical *900 lbs Choker *750 lbs Basket *1800 lbs DO NOT EXCEED WORKING

BOSS Strapping's sister company, HEM-SORT Slings, is the manufacturer of the highest quality Lumber Sorter Slings in the Saw Mill Industry. BOSS is using this experience to address an issue in the Wall Panel Industry.

WALL PANEL LIFTING LOOP		
*WLL	*Working Load Limit	
Vertical	*900 lbs	
Choker	*750 lbs	
Basket	*1800 lbs	
DO NOT EXCEED WORKING LOAD LIMIT		

- Rated For Lifting*
- Low-Cost Disposable Loops & Simple To Use!
- Certification Printed On Each Loop For Inspectors
- No More Damaged Panels
- A New Safe, More Efficient Way To Lift & Set Panels

* SEE TAG - DO NOT EXCEED WORKING LOAD LIMIT

Call 936-867-4801 for samples and pricing information.

© FEB 2019

SIMPLY THE BEST SOLUTION FOR ALL YOUR NEEDS!



Lumber & Industrial Lifting Slings

CUSTOM INDUSTRIAL SLINGS MADE TO ORDER

Item #	Description	Item #	Description
81045	3.875" x 8' Silver Printed eye & eye	ES30	4" x 30' Lumber Sling w/D-Ring
81046	3.875" x 25' Silver Printed Double Ply eye & eye bundler sling	ES35	4" x 35' Lumber Sling w/D-Ring
81047	3.875" x 30' Silver Printed w/H-S end	ES40	4" x 40' Lumber Sling w/D-Ring
81048	3.875" x 35' Silver Printed w/H-S end	ES40T	4" x 40' Lumber Sling w/Alum Triangle
81049	3.875" x 40' Silver Printed w/H-S end	ES42	4" x 42' Lumber Sling w/D-Ring
81050	3.875" x 40' Silver Printed w/T-3 end	ES50	4" x 50' Lumber Sling w/D-Ring
81052	3.875" x 50' Silver Printed w/H-S end	ES50T	4" x 50' Lumber Sling w/Alum Triangle
81053	3.875" x 50' Silver Printed w/T-3 end	ES60	4" x 60' Lumber Sling w/D-Ring
81060	3.875" x 60' Silver Printed w/H-S end	ES40IM	4" x 40' Lumber Sling w/Standard eye one end, special eye at hook up end
IM-35	3.875" x 35' Silver Printed Standard eye one end, special eye at hook up end	ES50IM	4" x 50' Lumber Sling w/Standard eye one end, special eye at hook up end
IM-40	3.875" x 40' Silver Printed Standard eye one end, special eye at hook up end		
IM-50	3.875" x 50' Silver Printed Standard eye one end, special eye at hook up end		

H-S - HEM-SORT Slings patented metal 'D'-ring (greater strength, longer life and safer fitting)

T-3 end - Aluminum Triangle / IM - Irvington Moore Shorter Sling (length)

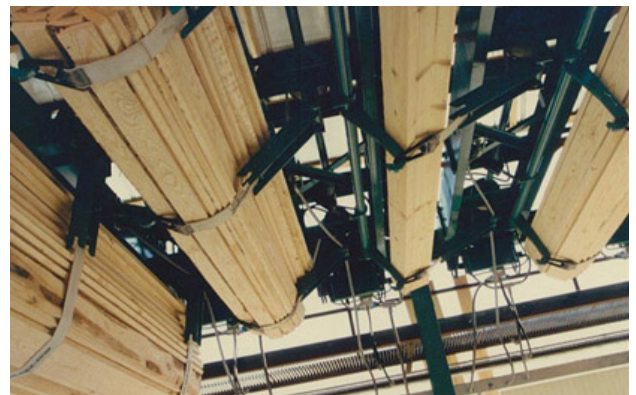

Tiedowns and Hardware



1" Tiedown
Available In Any
Length w/ Hardware



2" & 4" Tiedowns
Available In Any
Length w/ Hardware



1" x 14' Ratchet
w/ Wire Hook



2" Polyester Tiedown w/ Ratchet Flat Hook
Available In Any Length
CALL FOR A QUOTE



2" Polyester Web
w/ Flat Hook



4" x 30'
Polyester Web
w/ Flat Hook



Ratchet
Assembly w/
Flat Hook



2" x 30' Polyester Tiedown
w/ Ratchet Wire Hook



2" Ratchet
Replacement
Assembly w/ Any Hook



Ratchet
Assembly w/
Any Hook



2" Replacement
Tiedown Assembly w/
Chain Anchor



Ratchet
Assembly w/
Chain Hook



2" Ratchet
Tiedown Assembly



Ratchet
Assembly w/ Twisted
Snap Hook



2" Snap Hooks
5,000 to 10,000 lbs



Hook For Ratchet
Buckle w/ Spacer
5,000 lbs



2" Ratchet
w/ Snap Hook
5,000 lbs



1" Ratchet
3,300 lbs



1-1/2" Light Duty
Ratchet
4,000 lbs



2" Short Narrow
Heavy Duty Ratchet
10,000 lbs



2" Long Wide
Handle Ratchet
10,000 lbs



4" Ratchet
20,000 lbs

Contact Us Today : Tiedowns Available In Any Length

Tiedowns and Hardware



10" Plastic Corner Protector



4" Plastic Corner Protector



2" Wire D Ring
5,000 lbs



2" Delta Ring
10,000 lbs



2" Heavy Duty D Ring
10,000 lbs



4" Forged D Ring
20,000 lbs



U Bracket For Ratchet w/ Chain End
11,000 lbs



2" Spring Loaded "E" END Fitting
4,000 lbs



2" Cam Buckle
2,500 lbs



Clevis Grab Hook
G 43 5/16"



Clevis Grab Hook w/ Pearlink
16,200 lbs



Clevis Grab Hook
G 70 5/16"



Chain Anchor w/ 3" D Ring
16,200 lbs



4" Flat Hook
20,000 lbs



2" Flat Hook
10,000 lbs



1" Light Duty Small Flat Hook



1" Heavy Duty Flat Hook



2" Narrow Flat Hook
5,000 lbs



1" Wire Hook
3,000 lbs



2" Light Duty Wire Hook
3,000 lbs



2" Wire Hook
10,000 lbs



3" Wire Hook
16,200 lbs



1" Vinyl Coated S Hook
1,200 lbs



Web Winder



Oblong Master Links



Chain Load Binder
Fits 5/16" X 3/8"



Winch Bar Painted Standard or Combo w/ Box



G 70 3/8 x 20' Binder Chain



Standard Weld on Winch



Winch Standard Portable w/ 2-set Screws

Request A Quote For Custom Tiedowns



OUR HISTORY



BOSS Tiedowns and Strapping systems and our sister company, HEM-SORT Slings, are manufactured at our factory in Wells, Texas. We have proudly served the lumber industry with woven products for over 45 years.

BOSS Tiedowns and Strapping have provided strapping solutions through decades of banding experience in nylon strapping, polyester strapping, webbing, narrow fabrics, customized strapping and several strapping tools.

If you need tiedowns, buckles, poly strapping, lashing, or slings that are heavy-duty, industrial or just for everyday use we have the experience and expertise to solve any strapping problem big or small.

From agricultural applications, construction and development to manufacturers and shipping companies, our customer service professionals have on-site experience to help you find the right straps, strapping tools and banding accessories for your operation.

When you choose BOSS Tiedowns and Strapping, you're getting the Best Overall Strapping System available within the industry. Gain the confidence of safe and secure strapping solutions and accessories engineered with precision and manufactured to the highest standards.

For superior performance use BOSS Strapping Solutions Certified products. We stand ready to help you outfit your operations, customers, and team with the best quality products!



Top 5 Reasons Companies Choose BOSS Tiedowns & Strapping

Whether you need strapping, lashing, buckles, or tiedowns that are heavy-duty for industrial or just for everyday use BOSS has the experience and expertise to solve any strapping problems big or small.

#1 Proven Performance

With decades of experience, BOSS Tiedowns & Strapping has proven its products are tough enough to perform under pressure.

#2 Return on Investment (ROI)

ROI is an important measure when considering any purchase. BOSS products return value through increased safety and productivity.

#3 Increased Productivity

BOSS promotes LEAN Process Improvement to make sure that you are getting the full value out of every dollar invested.
SAVE TIME & SAVE MONEY

#4 Cost Savings

Decreased tooling costs, increased safety, and stable pricing all mean BOSS Tiedowns & Strapping is a smarter more cost-effective choice.

#5 Improved Safety

BOSS Tiedowns & Strapping prides itself on helping make your business safer through the conversion from steel banding to a much smarter strapping alternative.



Best Overall Strapping System

See the full story at



Identify these non-value-adding activities.
Reduce or eliminate them to become safer and more efficient.

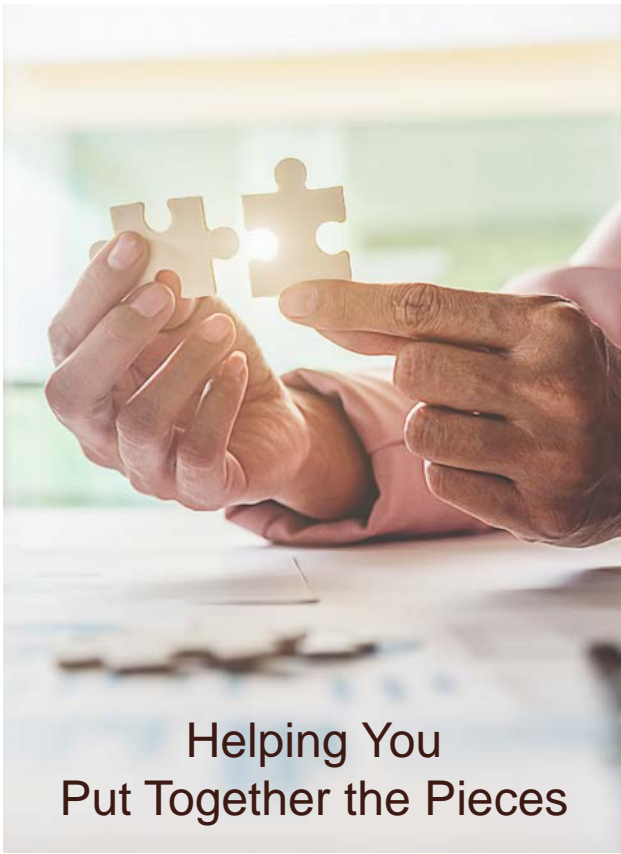

LEAN INTO SAFETY

Imagine if all of your employees showed up to work tomorrow with the commitment of an owner. What if they took ownership of the work they did for you each day? What if they cared for the equipment and resources as if it belonged to them?

We believe that it's not only possible but that it is just one of the endless benefits of building a LEAN Culture within your company. We look forward to discussing with you how our products and services can assist you in your LEAN Journey.



Jeff Tweten, Founder/Managing Member
WorkSafeWorkSmart.com, LLC
Co-Founder Lumber Buddy™ Productivity Products



Lean Fanatic
Visited over 1,800 Lumber Yards on his LEAN Journey

Inspired by Paul Akers and his book "2-Second Lean", Jeff has shared this story of LEAN Process Improvement and Culture Building with over 300 companies across North America.

Email: JeffT@WorkSafeWorkSmart.com | Office: (469) 708-9797



YOUR PROCESSES AND PROCEDURES



Check Out Our New Website

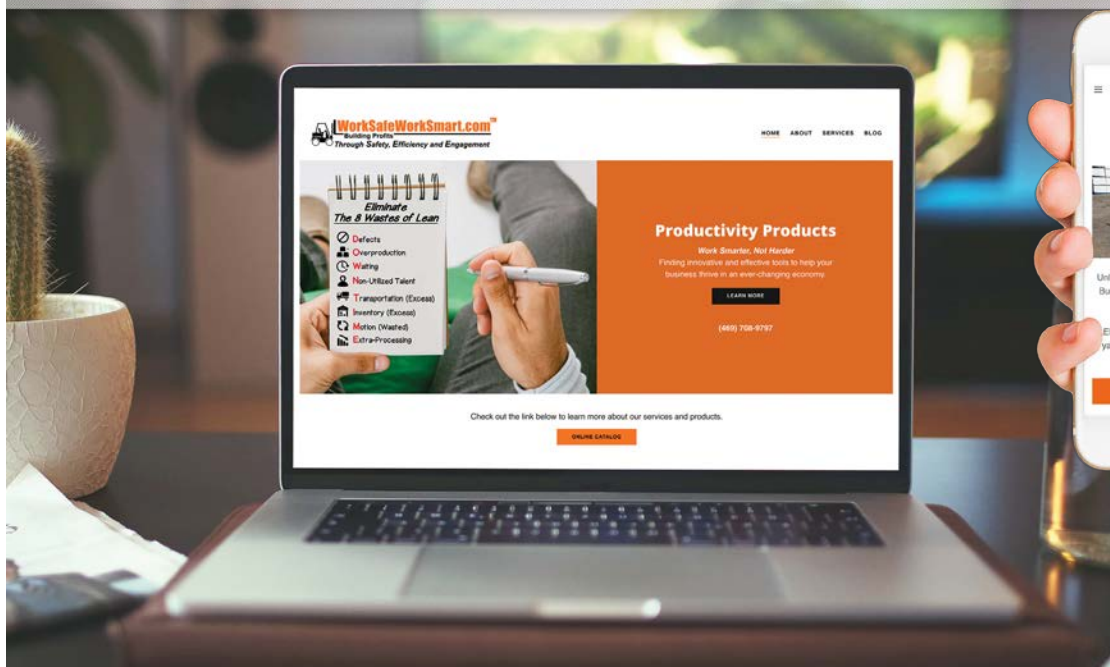

WorkSafeWorkSmart.com, LLC
PO Box 888
Nevada, MO 64772

Phone: (469) 708-9797
Fax: (417) 228-9032

Online: BOSS-Strapping.com
LumberBuddy.com
PatriotStrapping.com
LMSaws.us



Scan Now
Website