



SENSORWORX®

WIRELESS POWER PACK LOAD CONTROLLER

LINE VOLTAGE

OVERVIEW

SENSORWORX wireless power pack controllers switch on/off power to a connected lighting load as directed by wirelessly linked sensors, photocells, and wall controls. Additionally, the unit's 0-10V dimming option greatly simplifies applications where dimming control from multiple switch locations is required. For applications where a hybrid wireless/wired architecture is desired, this wireless power pack can also be ordered with auxiliary low voltage connections.

The **SENSORWORX** wireless power pack is rated to switch fully loaded circuits and utilizes a powerful microprocessor to optimize its switching timing, ensuring long relay life even when controlling high-inrush LED lighting. As with all **SENSORWORX** products, these power packs are easy to install and incorporate features which reduce contractor labor time. An elongated chase nipple with snaps for quick installation and an optional snap-on low voltage wire chamber make for a hassle free contractor experience. All **SENSORWORX** products are proudly made in the USA.

BASIC OPERATION

A received wireless message indicating occupancy from one or more wirelessly linked sensors will trigger the pack's integrated relay to close. When configured for Vacancy operation, an ON switch message is required from a wirelessly linked wall station to initially trigger lights. Once closed, line voltage will flow through the relay and turn on the connected lighting load. The wireless power pack maintains a master time delay that is reset every time a linked sensor reports occupancy. Lights will be switched off once there hasn't been an occupancy message reported for the duration of the time delay. If linked to a photocell, the unit receives light level readings and controls connected lighting according to its photocell operating mode.

FEATURES

- Wirelessly Links to Sensors, Photocells, & Wall Stations
- Links in Seconds up to 50 Remote Devices
- Switches Up to 20A Line Voltage Loads
- Electronically Timed Switching Ensures Long Relay Life
- Integrated Test/Programming Button
- Plenum Rated (UL 2043)
- Configurable Time Delays and Operational Modes (e.g. Occupancy/Vacancy)
- Configurable Daylight Harvesting & Photocell Modes
- Optional 0-10V Dimming Output for Partial On & Partial Off Operation
- Optional Wired Connectivity to Low Voltage Sensors & Wall Stations

SPECIFICATIONS

ELECTRICAL

OPERATING VOLTAGE

120/277 VAC,
Single Phase, 50/60 Hz

CLASS 2 POWER OUTPUT

18 VDC @ 70 mA (-AX version),
higher output when unloaded

LOAD RATINGS

20A @ 120 VAC -
General Purpose Plug Load

20A @ 120/277 VAC -
General Purpose, Tungsten,
Magnetic Ballast

16A @ 120/277 VAC -
Electronic Ballast, LED Driver

DC LOAD RATINGS

20A @ 28 VDC (MAX)
1A @ 5 VDC (MIN)

DIMMING LOAD

(Models with -D2 option only)
50mA, (0-10 VDC ballasts or
drivers compliant with IEC 60929
Annex E.2)

MOTOR LOAD

1 HP

ESD IMMUNITY

Tested to withstand electrostatic
discharge without damage or
memory loss

ENVIRONMENTAL

OPERATING TEMP

32°F to 122°F (0°C to 50°C)

RELATIVE HUMIDITY

0-95% Non-Condensing
Indoor Use Only

CODE COMPLIANCE

These power packs can be used to
meet ASHRAE 90.1, IECC, & Title
24 energy code requirements

WIRELESS

RANGE

80' line of site w/o obstruction
40' with obstruction (walls/floors)

FREQUENCY

915 MHz ISM Band

WIRELESS LINKING

Simple 3 sec. Push Button Process

SECURITY

All Wireless Data is Encrypted

PHYSICAL

SIZE

3.00" H x 2.25" W x 1.88" D
(7.62 cm x 5.72 cm x 4.78 cm)

WEIGHT

6.00 oz.

COLOR

Blue

MOUNTING

1/2" Knockout

TEST / PROGRAMING BUTTON

LED STATUS INDICATOR

Bi-color White & Blue

OPERATION

OPERATING MODES

Occupancy & Vacancy
Partial On/Off (-D2 option)
Daylight Harvesting (-D2 option)
On/Off/Inhibit Photocell

TIME DELAY OPTIONS

1, 5, 10, 15, 20, 30 min.



ORDERING INFO

SAMPLE MODEL # SWX-950-D2

	PRODUCT	FUNCTIONALITY	VOLTAGE	OPTIONS				
SWX	Power Pack	9	Wireless Power Pack Load Controller, 20A	5	120/277 V	0	None Auxiliary Hybrid Wired Connections Dimming Control (0-10V)	Blank - AX - D2
ACCESSORY	DESCRIPTION							
SWX-999	Snap-On Low Voltage Wiring Chamber							
SWX-910-AR	Auxiliary Contact Closure Relay Pack (Requires connection to SWX-950-AX-(D2) power pack)							

WIRING

MODEL #: SWX-950

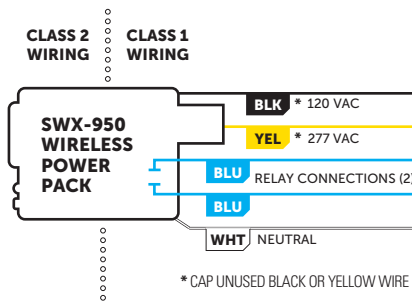

MODEL #: SWX-950-D2

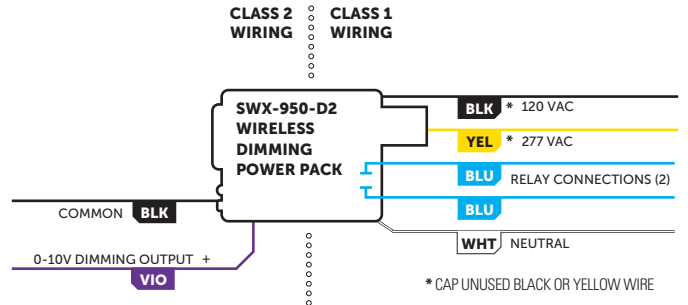

MODEL #: SWX-950-AX

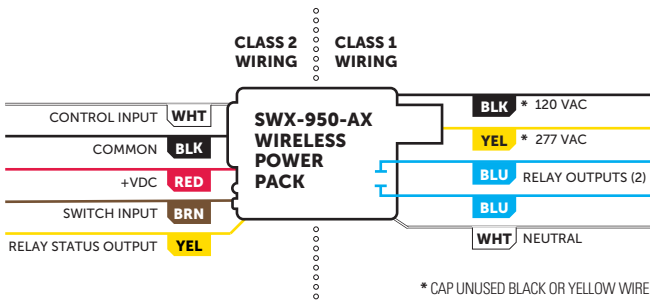

MODEL #: SWX-950-AX-D2

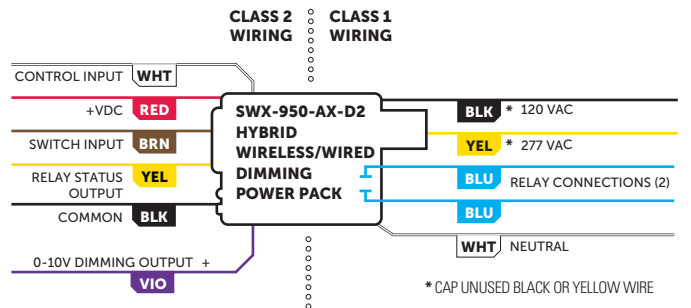

MODEL #: SWX-950-AX with SWX-910-AR

- Configuration provides a low voltage isolated contact closure relay that follows the standard relay in the SWX-950-AX wireless power pack.

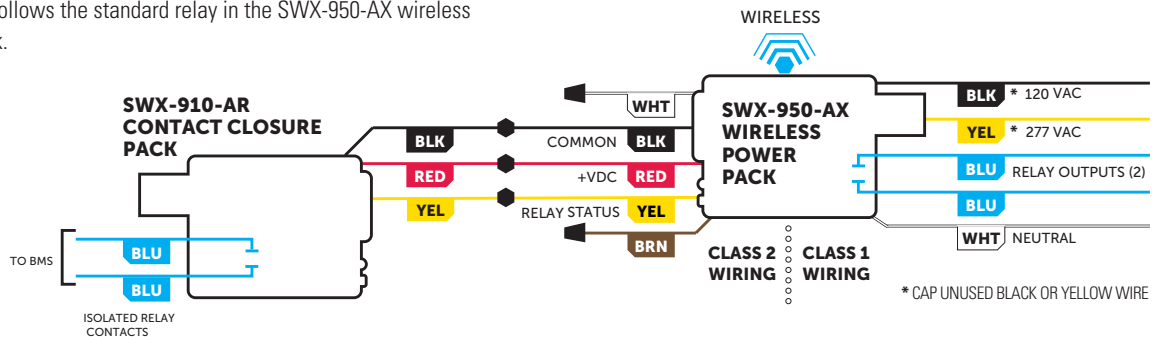

COMPATIBLE WIRELESS DEVICES

The below chart lists the devices that can be used in a **SENSORWORX** wireless application. Note that sensors, photocells, and remote switch & dimmer devices are transmit only devices and therefore must be linked to a load controller for switching and/or dimming of lighting.

MODEL #	DESCRIPTION	WIRELESS TYPE	POWER TYPE
SWX-201-B	Small Motion 360° Sensor, PIR	Transmit	Battery
SWX-211-B	Small Motion 360° Sensor, PIR w/ Integrated Daylight Harvesting Photocell	Transmit	Battery
SWX-221-B	Dual Technology Sensor (PIR/Acoustic), Small Motion 360°	Transmit	Battery
SWX-401-B	Wide View Sensor, PIR	Transmit	Battery
SWX-421-B	Dual Technology (PIR/Acoustic) Wide View Sensor	Transmit	Battery
SWX-402-B	Long Range Hallway Sensor, PIR	Transmit	Battery
SWX-250-B	Daylight Harvesting & On/Off Photocell	Transmit	Battery
SWX-851-xx	Wall Switch Load Controller, No Neutral Required, <xx = color>	Transmit & Receive	120-277 VAC
SWX-852-B-xx	Remote Switch (On/Off), <xx = color>	Transmit	Battery
SWX-854-B-xx	Remote Dimming Switch (On/Off, Raise/Lower), <xx = color>	Transmit	Battery
SWX-950	Power Pack Load Controller, 20A	Transmit & Receive	120/277 VAC
SWX-950-D2	Power Pack Load Controller, 20A, 0-10V Dimming	Transmit & Receive	120/277 VAC
SWX-950-AX	Hybrid Wireless/Wired Power Pack Load Controller, 20A	Transmit & Receive	120/277 VAC
SWX-950-AX-D2	Hybrid Wireless/Wired Power Pack Load Controller, 20A, 0-10V Dimming	Transmit & Receive	120/277 VAC

WIRELESS LINKING (PAIRING)

Linking a wireless power pack to a wireless sensor, photocell, or remote wall station is quickly done via the following procedure:

- Step 1.** Enter learn (pairing) mode by holding down the power pack's button for 3 seconds until the LED starts alternating white then blue, then release.
- Step 2.** At the sensor, photocell, or remote wall station, hold down the programming button for 3 seconds until the LED starts alternating white then blue. Releasing will link the device with the wireless power pack in learn mode (see note 1 below). The lighting load being controlled will also be toggled off/on as a visual indication of success.
- Step 3.** Repeat step 2 to link additional devices.
- Step 4.** When all devices have been linked, exit learn mode on the power pack by pressing the button 1 time. Learn mode will also be automatically closed after 15 minutes of no new devices being linked.

Note 1: When in learn mode, the alternating LED colors on the power pack will periodically pause and blink out the total number of linked devices. There will be no blinks during the pause until the first device is linked.

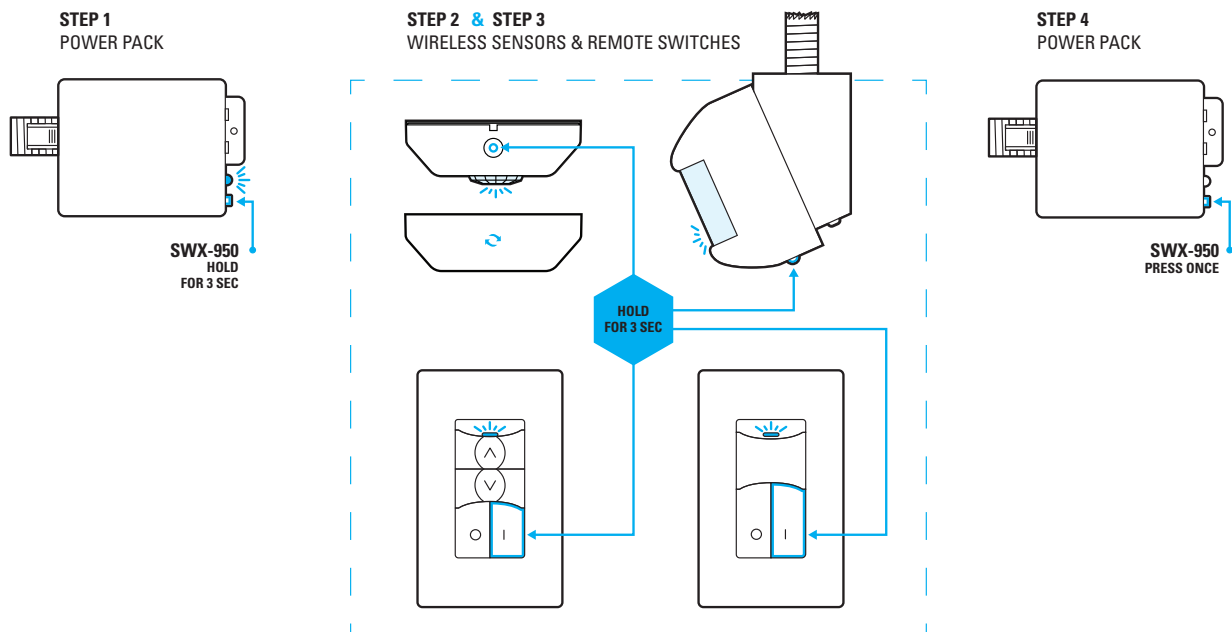

APPLICATION & OPERATION NOTES

GENERAL WIRELESS SENSOR OPERATION

- Wireless sensors periodically transmit their PIR and/or acoustic (if equipped) occupancy status. Referred to as the sensor's "heartbeat", this period is optimized to conserve battery life.
- If a sensor transmitted "unoccupied" at its last heartbeat, any new PIR detection event will be transmitted immediately.
- Using the information received from linked sensors, wirelessly linked power pack load controllers switch lighting accordingly.
- The power pack load controller has a master time delay that is initially set only when a PIR occupancy transmission is received from a linked sensor. The time delay will then be reset every time a sensor reports any occupancy (either PIR or acoustic). Lights will be switched off once all linked sensors have continuously reported unoccupied for the duration of the time delay.
- To prevent lights from staying on indefinitely from just acoustic events, after ~30 minutes the power pack will stop considering acoustic events from all linked sensors until after a PIR event is received again.
- As an added safety measure after lights are switched off, acoustic detection remains enabled for 15 seconds to enable voice reactivation of lights.
- If a wireless power pack does not receive any heartbeat transmissions from a linked sensor for 10 minutes it will blink out an error code (4 blue blinks, followed by a pause) and consider itself occupied (so as to override the lights on). If more than one sensor is linked, the sensor heartbeats from all sensors must have stopped for the error warning to begin blinking.

PHOTOCELL OPERATION

- The **Ambient Setpoint** and **Photocell Operating Mode** are settings stored within the wall switch controller. For all photocell applications (e.g. daylight harvesting), the power pack controller receives the light level readings being transmitted every 15 seconds by wirelessly linked photocells. The controller will then dim, turn off, or turn on connected lighting in order to maximize energy savings while maintaining desired minimum light level.
- The setpoint value initially is established by the running the Auto-Setpoint calibration procedure that is built into the wireless photocell. Once initially determined, the setpoint can be changed at the power pack controller by selecting from a list of values.
- The wireless power pack controller will only listen to a single wireless photocell sensor. If more than one is wirelessly linked, the unit that last ran the auto-setpoint calibration procedure will be used.
- The photocell control algorithm compensates for the contribution of the controlled lighting to the overall light level of the space. This prevents lights from cycling back on shortly after they are switched off by the photocell operation.
- When the unit's **Photocell Operating Mode** is set to Daylight Harvesting to Off, On/Off Operation, or Inhibit Operation, there is a 45 second transition time after the ambient light level falls below the setpoint to when the connected lighting is switched on. During this transition time, the LED on the power pack controller will be slowly blinking blue.
- When the unit's **Photocell Operating Mode** is set to Daylight Harvesting to Off or On/Off Operation, there is a 5 minute transition time after the ambient light level surpasses the setpoint to when the connected lighting is switched off. During this transition time, the LED on the power pack controller will be slowly blinking blue.
- Whenever lights are being held off due to the photocell, the blue LED will double blink every 15 seconds.
- Dimming from high trim to low trim (or in reverse) due to daylight harvesting requires ~1.5 minutes.

LEADER / FOLLOWER OPERATION & MULTI-ZONE DAYLIGHT HARVESTING

- Power pack controllers can be configured to directly "follow" the state and dim level of another wirelessly linked power pack controller (referred to as the "leader"). Leader/follower functionality is intended for applications where two power pack are to be controlled together, but where only one (designated the leader) is within range of the wireless switch or sensor. The follower power pack must still be within range of the leader power pack.
- A power pack in follower mode does not listen to any other wireless devices except the leader to which it is paired. Therefore, all wireless devices in a zone must be in range of the leader.
- The "leader/follower" functionality of power pack controllers can also be used to accommodate **multi-zone daylight harvesting** applications. The leader would be wired to control the primary daylight zone that contains the daylight harvesting photocell, with one or more follower power packs controlling the lights in secondary daylight zones (i.e. zones located further from the windows). The follower packs can then be configured to control the lights a percentage brighter than the leader (from 0-50%).

DIMMING OPERATION

- There are always 20 equal steps of dim level (voltage) adjustment from high trim to low trim (or reverse) when using a **SWX-854-B** wireless remote dimmer.
- For areas such as stairwells, the **SWX-950-D2** unit can be used to achieve **Partial Off** operation where lighting is at the full bright level when occupied and dropped to the 50% (level is configurable) during unoccupied periods.
- **Partial On** operation can be achieved by the **SWX-950-D2** unit. In this configuration 0-10V lighting is turned on to a configurable **Partial On Level** when triggered from an occupancy sensor or switch. Lighting can then be adjusted to any level via a wirelessly linked **SWX-854-B** remote dimmer. Alternatively, if the ON button is pushed on a wirelessly linked **SWX-852-B** or **SWX-854-B** remote switch, lighting will be stepped up to 100% (level is user configurable). Lighting can be turned off manually via an OFF switch press on either the **SWX-852-B**, **SWX-854-B** wireless remote switch (or single button push on a **SWX-851** switch controller).
- Configurable dimming parameters include **Turn On / Partial On Level**, **Turn Off Scheme**, **Fade On/Fade Off Rates**, and **High/Low Dimming Trim Levels**.
- A model **SWX-801-xx** wired momentary switch can be wired to a **SWX-950-AX-D2** model power pack to trigger the 3 step sequence of operation (i.e. Partial On, Full On, Off). Other manufacturer's switches may also be utilized.

APPLICATION & OPERATION NOTES (CONT.)

HYBRID WIRED / WIRELESS OPERATION

- A **SWX-950-AX** or **SWX-950-AX-D2** power pack wirelessly retransmit any switch signals received on its brown input wire (typically from a **SWX-801** or **SWX-803** momentary switch or a low voltage wall switch sensor). To receive the retransmitted switch signals, a remote load controller (i.e. another **SWX-950** power pack or **SWX-851** wall switch controller) will need to be linked to the transmitting power pack.

INSTALLATION

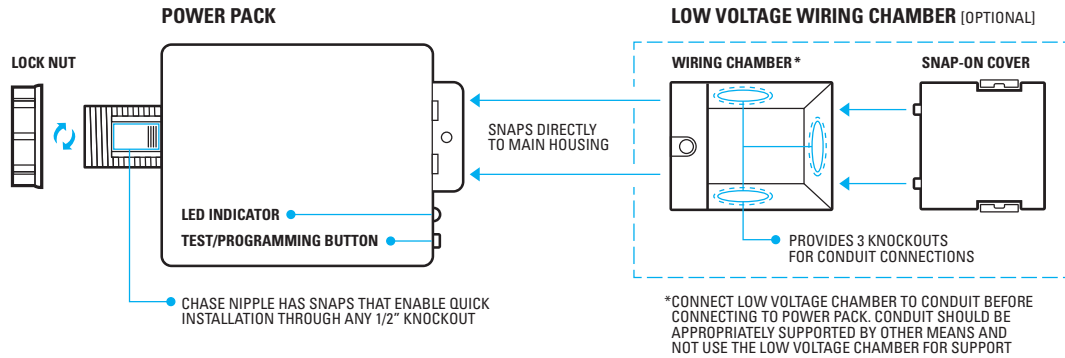

POWER PACK CAPACITY (SWX-950-AX-(D2) MODELS ONLY)

SWX-950-AX-(D2) series power packs can supply power to several occupancy sensors and low voltage wall switches. Following the below formula ensures adequate power will be available.

$$[(\# \text{ of PIR SENSORS}^*) \times 2\text{mA}] + [(\# \text{ of DUAL TECH SENSORS}) \times 10\text{mA}] + [(\# \text{ of SWITCHES}) \times 2\text{mA}] < [(\# \text{ of SWX-950-AX}) \times 70 \text{ mA}]$$

EXAMPLE CALCULATIONS	PIR SENSORS		+	DUAL TECH SENSORS		+	LOW VOLTAGE WALL SWITCHES		=	TOTAL POWER REQUIRED	<	POWER SUPPLIED BY ONE SWX-950-AX
	#	TOTAL POWER REQUIRED		#	TOTAL POWER REQUIRED		#	TOTAL POWER REQUIRED				
	15	30mA	+	0	0	+	2	4	=	34mA	<	70mA
	0	0	+	5	50mA	+	2	4	=	54mA	<	70mA
	3	6mA	+	3	30mA	+	2	4	=	40mA	<	70mA

FCC INFORMATION (FCC ID: 2AVRY-SWX0003)

This device complies with Part 15 of the FCC Rules. Operation is subject to the following conditions:

1. This device may not cause harmful interference, and
2. This device must accept any interference received, including interference that may cause undesired operation

Changes and Modifications not expressly approved by BLP Technologies can void your authority to operate this equipment under Federal Communications Commission's rules.

INDUSTRY CANADA INFORMATION (IC: 26012-0003)

This device complies with Industry Canada license-exempt RSS standard(s). Operation is subject to the following two conditions: (1) this device may not cause interference, and (2) this device must accept any interference, including interference that may cause undesired operation of the device.

Le présent appareil est conforme aux CNR d'Industrie Canada applicables aux appareils radio exempts de licence. L'exploitation est autorisée aux deux conditions suivantes : (1) l'appareil ne doit pas produire de brouillage, et (2) l'utilisateur de l'appareil doit accepter tout brouillage radioélectrique subi, même si le brouillage est susceptible d'en compromettre le fonctionnement.

