

New Generation Digital Infrared Wireless Conference System

Excellent solutions for conferences



Installation and Operating Manual

V 2.12

Remarks:

- All rights reserved for translation, reprint or reproduction
- Contents may change without prior announcement
- All technical specifications are guideline data and not guaranteed features
- We are not responsible for any damage caused by improper use of this manual
- The equipment must be connected to earth!
- This product conforms to the rules of the European directive 2014/30/EU.
- To protect your hearing avoid high pressure level on earphones. Adjust to a lower and convenient level.
- If any detailed information needed, please contact your local agent or TAIDEN service center in your region.
Any feedback, advice and suggestion about the products is appreciated.
- In order to extend the life time of whole system, we strongly recommend that the conference system be scheduled to shut down every day in the evening when not in use.
- TAIDEN is the registered trademark of TAIDEN Industrial Co., Ltd.

Important Safety Instructions

1. Read these instructions.
2. Keep these instructions.
3. Heed all warnings.
4. Follow all instructions.
5. The apparatus shall not be exposed to dripping or splashing and that no objects filled with liquids, such as vases, shall be placed on the apparatus.
6. The MAINS plug serving as a disconnection device should be easy to operate.
7. The apparatus should be connected to the MAINS socket-outlet with protective earth.
8. Clean only with dry cloth.
9. Do not block any ventilation openings. Install in accordance with the manufacturer's instructions.
10. Do not install near any heat sources such as radiators, heat registers, stoves, or other apparatus (including amplifiers) that produce heat.
11. Do not bypass the safety purpose of the polarized or grounding-type plug. A polarized plug has two blades with one wider than the other. A grounding type plug has two blades and a third grounding prong. The wide blade and the third prong are provided for your safety. If the provided plug does not fit into your outlet, consult an electrician for replacement of the obsolete outlet.
12. Protect the power cord from being walked on or pinched particularly at plugs, convenience receptacles, and the point where they exit from the apparatus.
13. Only use attachments/accessories specified by the manufacturer.
14. Do not leave the battery near the fire or under an environment over 60 °C (such as under direct sunlight in the car), otherwise it may damage the protection circuit of the battery and cause fire, explosion, leakage or heat generation.
15. Unplug this apparatus during lightning storms or when unused for long periods of time.
16. Refer all servicing to qualified service personnel. Servicing is required when the apparatus has been damaged in any way, such as power-supply cord or plug is damaged, liquid has been spilled or objects have fallen into the apparatus, the apparatus has been exposed to rain or moisture, does not operate normally, or has been dropped.
17. Do not place the equipment on any uneven or unstable stand; original product package or appropriate package should be used to avoid damage caused by strong impacts during transportation.

18. Power supply cords:
AC 100 V-120 V 60 Hz or AC 220 V-240 V 50 Hz
19. The quantity of connected transceivers in one system should not exceed prescribed quantity. For service, please contact the nearest TAIDEN Service Center.
20. All TAIDEN products are guaranteed for definite time (see the WARRANTY CARD for details) excluding the following cases:
 - A. All damage or malfunction caused by human negligence;
 - B. Damage or malfunction caused by improper operating by operator;
 - C. Parts damage or loss caused by disassembling the product by non-authorized personnel.
21. Use ONLY specified connection cable to connect the system equipment.
22. Upon receipt of the product, please fill out the Warranty Card enclosed and post it to TAIDEN Service Center nearby in your region.



TO REDUCE THE RISK OF ELECTRIC SHOCK, DO NOT EXPOSE THIS EQUIPMENT TO RAIN OR MOISTURE.

CAUTION: To reduce the risk of electric shock, DO NOT open covers, no useable serviceable parts inside. Refer servicing to qualified service personnel only.

This label appears on the rear of the unit due to space limitations



The lightning flash with an arrowhead symbol, with an equilateral triangle, is intended to alert the user to the presence of uninsulated 'dangerous voltage' within the products enclosure that may be of sufficient magnitude to constitute a risk of electric shock to persons.



The exclamation mark within an equilateral triangle is intended to alert the user to the presence of important operating and maintenance (servicing) instructions in the literature accompanying the appliance.

WARNING: These apparatuses shall not be exposed to dripping or splashing and no objects filled with liquids, such as vases shall be placed on the apparatus.

Important Safety Instructions

WARNING: To reduce the risk of electric shock, DO NOT expose units to rain or moisture.



Attention: Installation should be performed by qualified service personnel only in accordance with the National Electrical or applicable local codes.



Power Disconnect: Units with or without ON – OFF switch have power supplied to the unit whenever the power cord is inserted into the power source; however, the unit is operational only when the ON – OFF switch is in the ON position. The power cord is the main power disconnect for all units

WARNING: The apparatus should be connected to a mains socket outlet with a protective earthing connection.

Lithium battery safety precautions

- To change battery please power off and take off the battery immediately.
- Keep the battery away from heat sources to prevent fire or explosion.
- Do not use a battery that is leaking, deformed, discolored or overheats.
- Take extra precautions to keep a leaking battery from fire.
- Do not use a battery that emits odor or smoke.
- Do not solder, disassemble, puncture or deform the battery, otherwise, it may damage the protection circuit of the battery and cause fire, leakage or explosion.
- Do not short-circuit the positive and negative electrode with wire or other metal objects, otherwise it may cause fire, explosion, leakage or heat generation.
- Do not store or transport the battery with metal objects (such as necklace or hair grip), otherwise it may cause fire, explosion, leakage or heat generation.
- Do not heat the battery or throw it into fire, otherwise it may damage the safety valve or the protection circuit of the battery and may cause fire or explosion.
- Do not put the battery in the water or moisten the electrode of the battery, otherwise it may corrode the battery and cause fire, explosion, leakage or heat generation.
- Be careful to put the battery into the charging case with correct electrode position, otherwise it may cause fire, explosion, leakage or heat generation.
- Do not leave the battery near the fire or under an environment over 60 °C (such as in the car from direct sunlight), otherwise it may damage the protection circuit of the battery and cause fire, explosion, leakage or heat generation.
- Please charge the battery with the dedicated base plate, using other charging unit may cause fire, explosion, leakage or heat generation.
- Please use the battery in assigned unit, otherwise it may cause fire, explosion, leakage or heat generation.
- Do not drop or shock the battery, otherwise it may damage the protection circuit of the battery and cause fire, explosion, leakage or heat generation.
- If battery contents get into eyes it may cause blurred vision. DO NOT rub. Rinse with clear water immediately and consult a doctor.
- If the battery leaks onto skin or clothing, wash the area immediately with clean water to avoid skin injury and fabric damage.
- It will result in low battery and may damage the battery if the battery is not used for a long time. Please take off the battery, and fully charge the battery for every three months.

Contents

Installation & User Guide.....	IX
Chapter 1 System introduction	1
1.1 Overview.....	1
1.2 Functions and features	4
1.3 System technology	5
1.3.1 Basic system concept.....	5
1.3.2 IR radiation	5
1.3.3 Carriers and channels	5
1.4 Aspects of infrared signal transmission	6
1.4.1 Ambient lighting.....	6
1.4.2 Objects, surfaces and reflections	6
1.4.3 Infrared service area of digital infrared wireless conference unit.....	7
1.4.4 Infrared service area of digital infrared transceiver.....	8
1.4.5 Overlap and multipath effects.....	9
Chapter 2 HCS-5300M/80A Series Digital IR Wireless Conference System Main Unit	10
2.1 Overview.....	10
2.2 Functions and indications	11
2.3 Installation.....	13
2.4 Connection.....	14
2.4.1 To interpretation devices	14
2.4.2 To other auxiliary devices.....	14
2.4.3 To HCS-8300MI series	15
2.4.4 System connection 1	16
2.4.5 System connection 2	17
2.4.6 System connection 3	19
2.4.7 Load capacity	21
2.5 Configuration and operation	22
2.5.1 Audio Mode Setting	23
2.5.2 Operation	26
2.5.3 Active Micro's	26
2.5.4 System Status	26
2.5.5 SI Setting.....	26
2.5.6 Line In 1 Setting	28
2.5.7 Line In 2 Setting	28
2.5.8 Headphone Auto Att.	28
2.5.9 Ring Setting.....	28
2.5.10 Chairman Priority.....	28
2.5.11 Mic. Parameters	29
2.5.12 Mic. Auto Off.....	29
2.5.13 Language	30
2.5.14 Network Setting.....	30
2.5.15 Time Setting	30

2.5.16 Video Tracking.....	30
2.5.17 Mute Speaker	30
2.5.18 Alarm Setting	31
2.5.19 Backup/Restore.....	31
2.5.20 Voice Mode Setting	31
2.5.21 WiredMic Function.....	32
2.5.22 Number	32
2.5.23 Mic. IR Strength.....	32
2.5.24 Mic. Led Setting.....	32
2.5.25 USB Audio Setting.....	33
2.5.26 License.....	33
2.5.27 Dante Audio Mode.....	33
2.5.28 RS-232 Baudrate.....	33
2.5.29 Noise Elimination.....	33
2.5.30 Line Out1 Noise Gate	33
2.5.31 Retractable Mic.	34
2.5.32 Interp. Outgoing.....	34
2.5.33 Interp. Units LED	34
2.5.34 Voice of God Setting.....	34
2.5.35 One Touch Turn On	34
2.5.36 Floor From MI SI	35
2.5.37 Screensaver	35
2.5.38 Dante Boost	35
2.5.39 About	35
2.5.40 About Dante	35
2.5.41 Power Management	35
2.6 USB Audio	37
2.6.1 Installation of USB Audio.....	37
2.6.2 Digital audio input.....	38
2.6.3 Digital audio output.....	39
Chapter 3 Digital infrared transceiver	40
3.1 Overview.....	40
3.2 Functions and indications	40
3.2.1 Digital infrared transceiver.....	40
3.2.2 Digital infrared cable splitter	41
3.3 Infrared service area.....	42
3.4 Position planning	43
3.4.1 Precautions in planning the digital infrared transceiver/receiver.....	43
3.4.2 Planning digital infrared transceiver	45
3.4.3 Planning the path from main unit to transceiver	48
3.5 Installation.....	50
3.5.1 Installation of HCS-5300TD/80.....	50
3.5.2 Installation of HCS-5300TDS/80	55
3.5.3 Installation of HCS-5300TH/80.....	57
3.5.4 Installation of HCS-5300TWN/80	60
3.6 Connecting to main unit	64

Chapter 4 HCS-5300/80 Series digital infrared wireless conference unit	65
4.1 Overview	65
4.2 Functions and indicating	66
4.3 Infrared service area	69
4.4 Precautions in using	70
4.5 Operation	71
4.5.1 The operation of delegate unit.....	71
4.5.2 The operation of chairman unit.....	73
Chapter 5 HCS-5380 Series digital infrared wireless conference unit	74
5.1 Overview	74
5.2 Functions and indicating	75
5.3 Infrared service area	77
5.4 Precautions in using	77
5.5 Operation	78
5.5.1 The operation of delegate unit.....	78
5.5.2 The operation of chairman unit.....	80
Chapter 6 HCS-5381 Series digital infrared wireless conference unit	81
6.1 Overview	81
6.2 Functions and indicating	82
6.3 Infrared service area	84
6.4 Precautions in using	84
6.5 Operation	85
6.5.1 The operation of delegate unit.....	85
6.5.2 The operation of chairman unit.....	86
Chapter 7 Web control software	87
7.1 Login and exit	87
7.2 Conference management	89
7.2.1 Assign unit ID to delegate.....	89
7.2.2 Speaking and request list	90
7.2.3 CMU setting	91
7.2.4 Video matrix	92
7.2.5 Predefined position.....	94
7.2.6 S.I. setup	95
Chapter 8 Accessories	97
8.1 Digital IR conference room switcher	97
8.1.1 Functions and indications.....	97
8.1.2 Connection	98
8.1.3 Configuration and operation	100
8.2 Accessories	101
8.3 Charging device.....	102
8.4 Dedicated extension cable for digital infrared transceiver	103
8.5 Power adapter	103
8.6 HCS-5300TZJ2 transceiver stand	104

8.7 Earphones	105
Chapter 9 Fault diagnosis	106
9.1 Digital infrared wireless conference unit	106
9.2 Digital infrared wireless main unit	107
9.3 Charging Unit.....	107
Chapter 10 Technical data.....	108
10.1 System specification	108
10.2 Digital infrared wireless main unit of HCS-5300M/80	109
10.3 Digital infrared transceiver	110
10.4 HCS-5300/80 Series digital infrared wireless conference unit.....	112
10.5 HCS-5380 Series digital infrared wireless conference unit.....	114
10.6 HCS-5381 Series digital infrared wireless conference unit.....	115
10.7 Digital IR Conference Room Switcher	117
10.8 Lithium battery	117
10.9 Charging Device	118
10.10 Power adapter	118
10.11 Distributor	119
10.12 CBL-5300 Dedicated extension cable	119
10.13 HCS-5300ZJ2 transceiver stand.....	119
10.14 Earphones	120
10.15 Connection details	121
10.16 Display language list.....	122
Appendix	123
Dedicated 6 PIN Extension Cable	123

Installation & User Guide

About this manual

This manual is a comprehensive guide to the installation and operation of TAIDEN HCS-5300/80 new generation digital infrared wireless conference system. It includes the detailed description of the function and interface of the HCS-5300/80 system components, system connection and installation, system set-up and operation.

The manual is divided into the following chapters:

Chapter 1: Introduction

Introduction to the HCS-5300/80 system, as well as introducing the user into structure, technical principle, and aspects of system planning.

Chapter 2: HCS-5300M/80A series digital infrared wireless conference main unit

Detailed description of functions, connection, configuration and operation of HCS-5300M/80A series digital infrared wireless conference main unit.

Chapter 3: Digital infrared transceiver

Detailed description of functions, position planning, installation and connection of digital infrared transceiver.

Chapter 4: HCS-5300/80 Series digital infrared wireless unit

Detailed description of functions and operation of HCS-5300/80 series digital infrared wireless conference unit.

Chapter 5: HCS-5380 Series digital infrared wireless unit

Detailed description of functions and operation of HCS-5380 series digital infrared wireless conference unit.

Chapter 6: HCS-5381 Series digital infrared wireless unit

Detailed description of functions and operation of HCS-5381 series digital infrared wireless conference unit.

Chapter 7: Web control software

Descriptions in detail of the function and operation of Web control of Digital IR Wireless Conference System

Chapter 8: Peripheral equipment and accessories

Detailed description of peripheral equipment and accessories for Digital IR Conference Room Switcher, batteries, charging devices, power adapter and earphones.

Chapter 9: Fault diagnosis

Trouble-shooting guide for simple faults.

Chapter 10: Technical data

Mechanical and electrical details of the complete HCS-5300 equipment.

Installation & User Guide

This manual is applicable to:

■ Digital IR Wireless Conference System Main Unit

HCS-5300MA/80A

Digital IR Wireless Conference System Main Unit (discussion, voting, 1+7 CHs, with interface for HCS-4100/50 series Wired Congress Unit and Interpreter Unit, Dante interface)

HCS-5300MB/80A

Digital IR Wireless Conference System Main Unit (discussion, 1+7 CHs, with interface for HCS-4100/50 series Wired Congress Unit and Interpreter Unit)

HCS-5300MC/80A

Digital IR Wireless Conference System Main Unit (discussion)

■ Digital Infrared Transceiver and Receiver

HCS-5300TD/80

Digital Infrared Transceiver (ceiling, wall or tripod-mounted, suitable for less than 6 m height)

HCS-5300TDS/80

Digital Infrared Transceiver (suspension)

HCS-5300TH/80

Digital Infrared Transceiver (ceiling, wall or tripod-mounted, powered from HCS-5300M or power adapter, suitable for higher than 6 m)

HCS-5300TWN/80

Digital Infrared Transceiver (ceiling, wall or tripod-mounted)

■ Digital IR Wireless Conference Unit

HCS-5300CE/80

Digital IR Wireless Chairman Unit (discussion, voting, 1+7 CHs, cooperates with HCS-5100Plus series can achieve 8 CHs simultaneous audio)

HCS-5300DE/80

Digital IR Wireless Delegate Unit (discussion, voting, 1+7 CHs, cooperates with HCS-5100Plus series can achieve 8 CHs simultaneous audio)

HCS-5301D/80

Digital IR Wireless Delegate Unit (discussion, 1+7 CHs, 2 channel selectors, dual predefined positions, cooperates with HCS-5100Plus series can achieve 8 CHs simultaneous audio)

HCS-5302C/80

Digital IR Wireless Chairman Unit (discussion)

HCS-5302D/80

Digital IR Wireless Delegate Unit (discussion)

HCS-5380CVS

Digital IR Wireless Chairman Unit (discussion, voting, 1+7 CHs, cooperates with HCS-5100Plus series can achieve 8 CHs simultaneous audio)

HCS-5380C

Digital IR Wireless Delegate Unit (discussion)

HCS-5380DVS

Digital IR Wireless Delegate Unit (discussion, voting, 1+7 CHs, cooperates with HCS-5100Plus series can achieve 8 CHs simultaneous audio)

HCS-5380DDS

Digital IR Wireless Delegate Unit (discussion, 1+7 CHs, 2 channel selectors, dual predefined positions, cooperates with HCS-5100Plus series can achieve 8 CHs simultaneous audio)

HCS-5380DS

Digital IR Wireless Delegate Unit (discussion, 1+7 CHs, cooperates with HCS-5100Plus series can achieve 8 CHs simultaneous audio)

HCS-5380D

Digital IR Wireless Delegate Unit (discussion)

HCS-5381RC

Digital IR Wireless Chairman Unit (rectangular columnar metal microphone, discussion)

HCS-5381RD

Digital IR Wireless Delegate Unit (rectangular columnar metal microphone, discussion)

HCS-5381C

Digital IR Wireless Chairman Unit (discussion)

HCS-5381D

Digital IR Wireless Delegate Unit (discussion)

■ Mounting Suspension

HCS-5300TDP-05

Mounting Suspension for Digital Infrared Transceiver (0.5 m)

Installation & User Guide

HCS-5300TDP-10

Mounting Suspension for Digital Infrared Transceiver (1.0 m)

HCS-5300TDP-20

Mounting Suspension for Digital Infrared Transceiver (2.0 m)

■ **Software**

HCS-5300WS

Web control Software (CMU setting, microphone control, video matrix, S.I. setting)

■ **Digital IR Conference Room Switcher**

HCS-5300MX Digital IR Conference Room Switcher

■ **Distributor**

HCS-5352 Cable Splitter (1 input & 4 outputs)

■ **Lithium Rechargeable Battery Pack**

HCS-5300BAT

Lithium Rechargeable Battery Pack (11.1 V DC, for HCS-5300/01/02 series conference unit)

■ **Charging Device**

HCS-5300CHG/08

Charging Unit (8 pcs/case, for HCS-5300BAT)

HCS-5300CHG/06

Charging Unit (6 pcs/case, for HCS-5380/5381 series conference unit)

HCS-5300CHG/06A

Charging Unit (6 pcs/case, for HCS-5380 series conference unit)

■ **Power Adapter**

HCS-ADP15V Power Adapter (DC 15 V, 2.4 A)

HCS-ADP24V Power Adapter (DC 24 V, 1.5 A, for HCS-5300TW Digital Infrared Transceiver)

HCS-ADP24V2 Power Adapter (DC 24 V, 1.5 A, for 5300TWN Digital Infrared Transceiver)

TES-ADP5V Power Adapter (DC 5 V, 2 A)

■ **Dedicated Cable**

CBL5300-05	5 m Dedicated Transceiver Cable
CBL5300-10	10 m Dedicated Transceiver Cable
CBL5300-20	20 m Dedicated Transceiver Cable
CBL5300-30	30 m Dedicated Transceiver Cable
CBL5300-40	40 m Dedicated Transceiver Cable
CBL5300-50	50 m Dedicated Transceiver Cable
CBL5300-05CMP	5 m Dedicated Transceiver Cable (CMP)
CBL5300-10CMP	10 m Dedicated Transceiver Cable (CMP)
CBL5300-20CMP	20 m Dedicated Transceiver Cable (CMP)
CBL5300-30CMP	30 m Dedicated Transceiver Cable (CMP)
CBL5300-40CMP	40 m Dedicated Transceiver Cable (CMP)
CBL5300-50CMP	50 m Dedicated Transceiver Cable (CMP)

■ **Tripod**

HCS-5300TZJ2 Transceiver stand

■ **Earphones**

EP-820AS

Single Earphone (TRS connector, Ring: NC)

EP-829

Single Earphone (TRS connector, Ring: NC)

EP-830

Single Earphone (TRS connector, Ring: NC)

EP-960BH

Headphone (stereo, with Detachable Earshells, without Sponge Ear Pads)

HCS-5100PA Headphone (180° plug)

Chapter 1 System introduction

1.1 Overview

TAIDEN HCS-5300/80 series product is a digital infrared wireless conference system convenient for mobile use as well as for permanent installations. The flexibility of the wireless chairman and delegate units allows easy arrangements of various conferences.

The system consists of one digital infrared wireless conference main unit, one or more digital infrared transceivers and up to 1000 digital infrared wireless conference units.

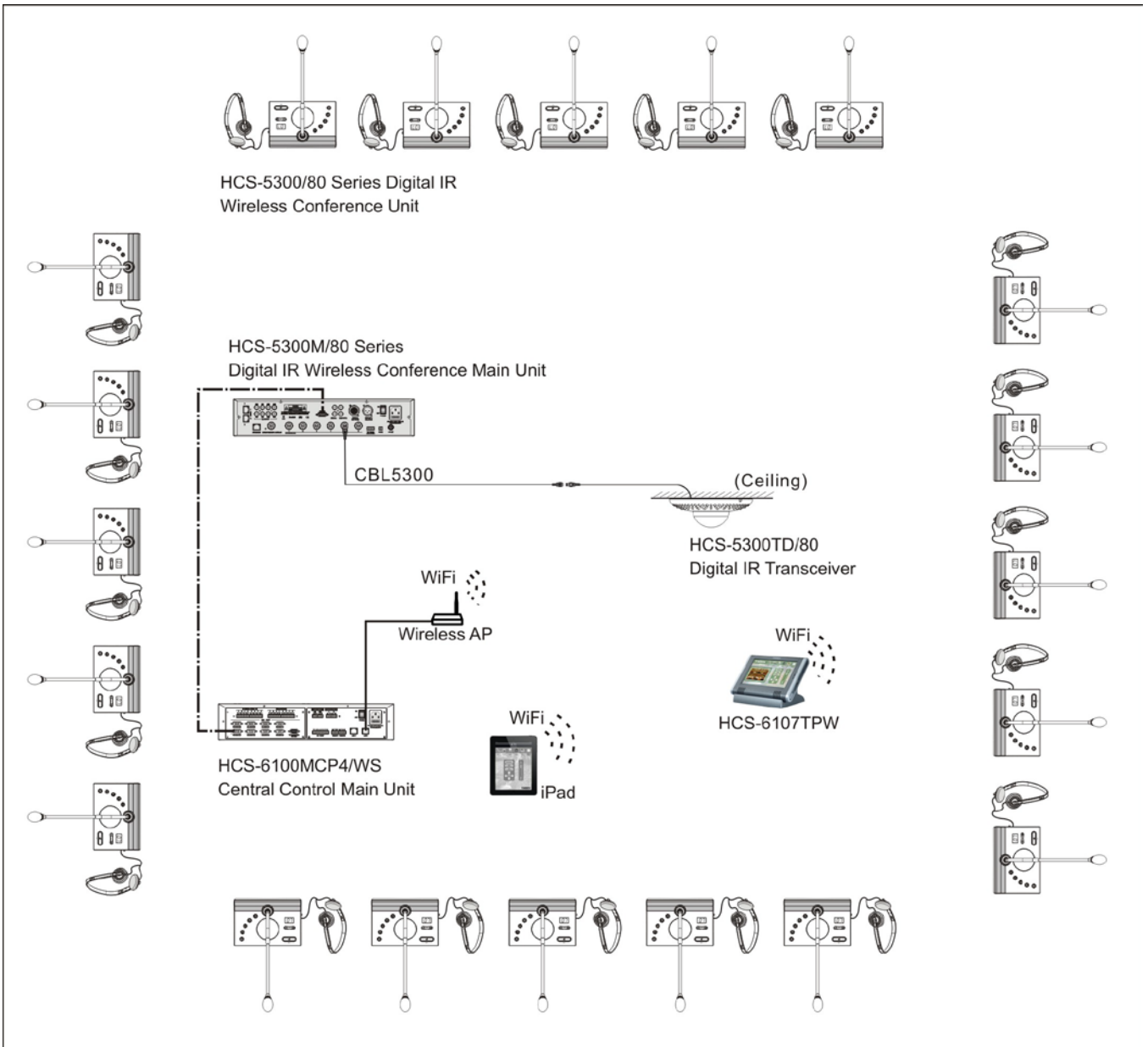

Figure 1.1 System overview

The system is composed of one or more of the following:

■ **Digital IR Wireless Conference System Main Unit**

HCS-5300MA/80A

Digital IR Wireless Conference System Main Unit (discussion, voting, 1+7 CHs, with interface for HCS-4100/50 series Wired Congress Unit and Interpreter Unit, Dante interface)

HCS-5300MB/80A

Digital IR Wireless Conference System Main Unit (discussion, 1+7 CHs, with interface for HCS-4100/50 series Wired Congress Unit and Interpreter Unit)

HCS-5300MC/80A

Digital IR Wireless Conference System Main Unit (discussion)

■ **Digital Infrared Transceiver and Receiver**

HCS-5300TD/80

Digital Infrared Transceiver (ceiling, wall or tripod-mounted, suitable for less than 6 m height)

HCS-5300TDS/80

Digital Infrared Transceiver (suspension)

HCS-5300TH/80

Digital Infrared Transceiver (ceiling, wall or tripod-mounted, powered from HCS-5300M or power adapter, suitable for higher than 6 m)

HCS-5300TWN/80

Digital Infrared Transceiver (ceiling, wall or tripod-mounted)

■ **Digital IR Wireless Conference unit**

HCS-5300CE/80

Digital IR Wireless Chairman Unit (discussion, voting, 1+7 CHs, cooperates with HCS-5100Plus series can achieve 8 CHs simultaneous audio)

HCS-5300DE/80

Digital IR Wireless Delegate Unit (discussion, voting, 1+7 CHs, cooperates with HCS-5100Plus series can achieve 8 CHs simultaneous audio)

HCS-5301D/80

Digital IR Wireless Delegate Unit (discussion, 1+7 CHs, 2 channel selectors, dual predefined positions, cooperates with HCS-5100Plus series can achieve 8 CHs simultaneous audio)

HCS-5302C/80

Digital IR Wireless Chairman Unit (discussion)

HCS-5302D/80

Digital IR Wireless Delegate Unit (discussion)

HCS-5380CVS

Digital IR Wireless Chairman Unit (discussion, voting, 1+7 CHs, cooperates with HCS-5100Plus series can achieve 8 CHs simultaneous audio)

HCS-5380C

Digital IR Wireless Delegate Unit (discussion)

HCS-5380DVS

Digital IR Wireless Delegate Unit (discussion, voting, 1+7 CHs, cooperates with HCS-5100Plus series can achieve 8 CHs simultaneous audio)

HCS-5380DDS

Digital IR Wireless Delegate Unit (discussion, 1+7 CHs, 2 channel selectors, dual predefined positions, cooperates with HCS-5100Plus series can achieve 8 CHs simultaneous audio)

HCS-5380DS

Digital IR Wireless Delegate Unit (discussion, 1+7 CHs, cooperates with HCS-5100Plus series can achieve 8 CHs simultaneous audio,)

HCS-5380D

Digital IR Wireless Delegate Unit (discussion)

HCS-5381RC

Digital IR Wireless Chairman Unit (rectangular columnar metal microphone, discussion)

HCS-5381RD

Digital IR Wireless Delegate Unit (rectangular columnar metal microphone, discussion)

HCS-5381C

Digital IR Wireless Chairman Unit (discussion)

HCS-5381D

Digital IR Wireless Delegate Unit (metal microphone, discussion)

■ **Mounting Suspension**

HCS-5300TDP-05

Mounting Suspension for Digital Infrared Transceiver (0.5 m)

HCS-5300TDP-10

Mounting Suspension for Digital Infrared Transceiver
(1.0 m)

HCS-5300TDP-20

Mounting Suspension for Digital Infrared Transceiver
(2.0 m)

- **Software**

HCS-5300WS

Web control Software (CMU setting, microphone control, video matrix, S.I. setting)

- **Digital IR Conference Room Switcher**

HCS-5300MX Digital IR Conference Room Switcher

- **Distributor**

HCS-5352 Cable Splitter (1 input & 4 outputs)

- **Lithium Rechargeable Battery Pack**

HCS-5300BAT

Lithium Rechargeable Battery Pack (11.1 V DC, for HCS-5300/01/02 series conference unit)

- **Charging Device**

HCS-5300CHG/08

Charging Unit (8 pcs/case, for HCS-5300BAT)

HCS-5300CHG/06

Charging Unit (6 pcs/case, for HCS-5380/5381 series conference unit)

HCS-5300CHG/06A

Charging Unit (6 pcs/case, for HCS-5380 series conference unit)

- **Tripod**

HCS-5300TZJ2 Transceiver stand

- **Power Adapter**

HCS-ADP15V Power Adapter (DC 15 V, 2.4 A)

HCS-ADP24V Power Adapter (DC 24 V, 1.5 A, for HCS-5300TW Digital Infrared Transceiver)

HCS-ADP24V2 Power Adapter (DC 24 V, 1.5 A, for 5300TWN Digital Infrared Transceiver)

TES-ADP5V

Power Adapter (DC 5 V, 2 A)

- **Dedicated Cable**

CBL5300-05 5 m Dedicated Transceiver Cable

CBL5300-10 10 m Dedicated Transceiver Cable

CBL5300-20 20 m Dedicated Transceiver Cable

CBL5300-30 30 m Dedicated Transceiver Cable

CBL5300-40 40 m Dedicated Transceiver Cable

CBL5300-50 50 m Dedicated Transceiver Cable

CBL5300-05CMP 5 m Dedicated Transceiver Cable (CMP)

CBL5300-10CMP 10 m Dedicated Transceiver Cable (CMP)

CBL5300-20CMP 20 m Dedicated Transceiver Cable (CMP)

CBL5300-30CMP 30 m Dedicated Transceiver Cable (CMP)

CBL5300-40CMP 40 m Dedicated Transceiver Cable (CMP)

CBL5300-50CMP 50 m Dedicated Transceiver Cable (CMP)

- **Earphones**

EP-820AS

Single Earphone (TRS connector, Ring: NC)

EP-829

Single Earphone (TRS connector, Ring: NC)

EP-830

Single Earphone (TRS connector, Ring: NC)

EP-960BH

Headphone (stereo, with Detachable Earshells, without Sponge Ear Pads)

HCS-5100PA Headphone (180° plug)

1.2 Functions and features

1. Digital infrared wireless conference system operating TAIDEN dirATC technology - digital infrared Audio Transmission and Control technology

2. Wireless conference system

- Quick set up and removal, free from troubles resulting from cable breaks and cable deteriorations
- Easy to set up a system within limited time
- No impact on furniture, interior equipment or building structure

3. Infrared transmission technology

- Conference privacy is guaranteed as infrared signals do not pass through opaque walls or ceilings
- Opaque partitions between conference rooms, allow to operate a system in each room
- Any quantity of infrared wireless conference systems can be installed within a building
- The infrared communication frees users from worries about eavesdropping and radio interference inherent to radio wave-based wireless communications
- No radio radiation
- No radio frequency license needed for operating an infrared system all over the world
- Adapts 1 to 8 MHz transmission frequency, undisturbed by HF driven light sources and mobile phones
- Work without errors, even in bright sunlight

4. Digital infrared audio transmission technology

Digital infrared audio processing and transmission technologies ensure sound quality:

- Frequency response: 80 Hz-20 kHz
- SNR: ≥ 90 dBA
- Total harmonic distortion: ≤ 0.05 %

5. Full functions

- Discussion
- Vote (3 or 5 keys)
- Simultaneous interpretation (1+7 channels)
- Isolated audio recording function for simultaneous interpretation (1+7 channels)
- Automatic video tracking
- USB interface realizing quality-lossless sound recording on PC and intact input of streaming audio into the system
- Web control function
- Compatible with HCS-5100Plus new generation digital infrared language distribution system
- Powerful application software modules

1.3 System technology

1.3.1 Basic system concept

The system composition of HCS-5300/80 digital infrared wireless conference system is shown in figure 1.2. It is composed of:

- Digital infrared wireless conference units for participators
- Digital infrared wireless conference main unit for system control
- Digital infrared transceiver(s) for connection to main unit

The digital infrared wireless conference main unit converts audio and/or control signals into carrier outputs which are transmitted to the digital infrared transceiver(s). In the digital infrared transceiver(s) the carriers are converted into modulated infrared light, sent to all digital infrared wireless conference units. The digital infrared transceiver(s) also receive infrared signals from every digital infrared wireless conference unit and convert the signals into audio or control signals which are transmitted to the main unit.

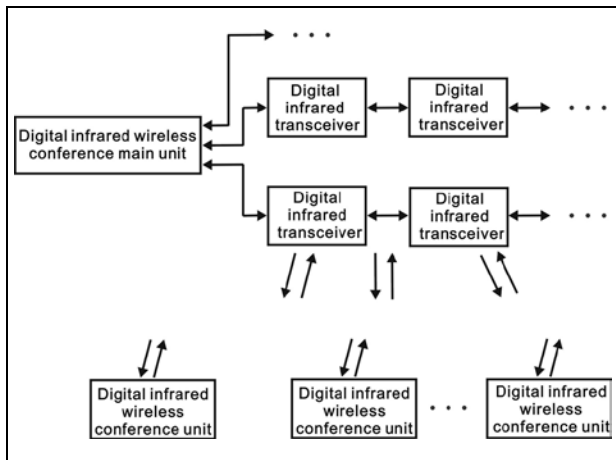

Figure 1.2 The basic system concept

1.3.2 IR radiation

Audio and control signals of HCS-5300/80 are transmitted as modulated infrared light. Infrared radiation is part of the electro-magnetic spectrum, which is composed of visible light, radio waves and other types of radiation. Its wavelength is longer in comparison with the wavelength of visible light.

Infrared light cannot pass through opaque walls and ceilings and guarantees privacy of the meeting by avoiding of being intercepted or disturbed. In addition,

infrared light has no radio radiation and a license is not required when operating infrared light systems.

1.3.3 Carriers and channels

TAIDEN HCS-5300/80 digital infrared wireless conference system adopts 1~8 MHz wave band (IEC 61603 BAND III, IV, V), shown as figure 1.3. This wave band is suitable for the transmission of wide band audio and corresponding signals. Please refer to table 1.1.

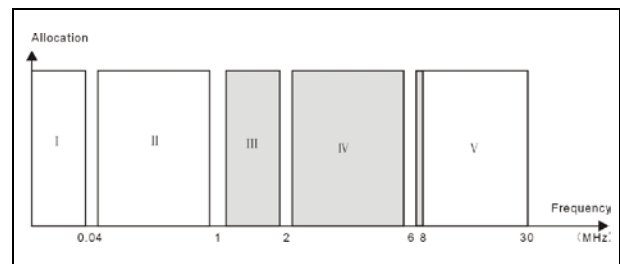

Figure 1.3 Standard wave band in HCS-5300/80 system

Route	Channel	Frequency
From conference unit(s) to main unit via transceiver	Audio channel 1	4.3 MHz
	Audio channel 2	4.8 MHz
	Audio channel 3	5.8 MHz
	Audio channel 4	6.3 MHz
	Control channel	3.8 MHz
From main unit to conference unit(s) via transceiver	Floor audio + interpretation audio (0-3) + Control signal	2.333 MHz
	Floor audio + interpretation audio (4-7) + Control signal	1.666 MHz

Table 1.1 Channels and corresponding frequencies in HCS-5300/80 system

1.4 Aspects of infrared signal transmission

To benefit from the advantages of a digital infrared wireless conference system the signals should be transmitted undisturbed. This is achieved by using digital infrared transceivers well positioned and sufficient in quantity to ensure uniform and adequate infrared radiation for all conference units.

When planning a digital infrared wireless conference system, several aspects influencing the uniformity and quality of the infrared signal should be considered. These are discussed in the next sections.

1.4.1 Ambient lighting

HCS-5300/80 system adopts 1~8 MHz wave band, and has very good anti-interference performance (see figure 1.4, figure 1.5).

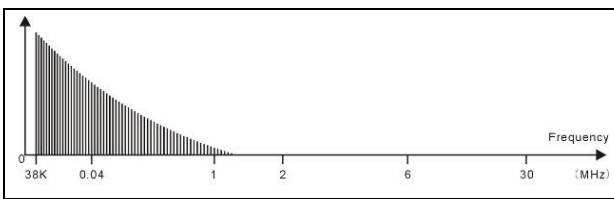

Figure 1.4 High frequency lights disturbance from HF driven light sources (energy-saving lamps)

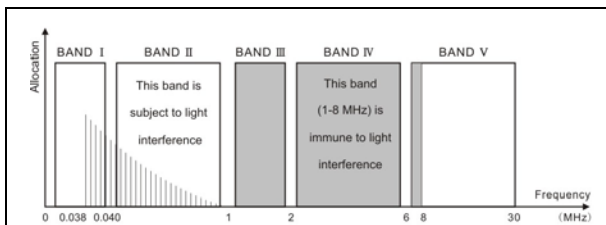

Figure 1.5 New generation digital infrared conference system with 1-8 MHz wave band can avoid high frequency lights disturbance

For meeting rooms with large, unshielded windows, multi-transceiver operation should be considered. For outdoor using, a site test will be required to determine the needed amount of transceivers. With sufficient transceivers, perfect signal transmission can be fulfilled even in bright sunlight.

1.4.2 Objects, surfaces and reflections

Just like visible light, infrared radiation is reflected from hard surfaces and refracted by hyaloid (glassy or transparent appearance) items. Objects in the conference venue as well as structure of the walls and ceilings will influence the distribution of infrared light.

Infrared radiation is reflected from almost all hard surfaces. Smooth, bright or shiny surfaces reflect well. Dark or rough surfaces absorb a large part of the infrared energy. Usually, surfaces opaque to visible light are also opaque to infrared radiation.

Shadows from walls and furniture will influence the transmission of infrared light. This can be solved by using a sufficient quantity of transceivers. They should be positioned in a manner to provide an infrared field strong enough to cover the whole conference area.

Make sure that each infrared wireless conference unit can communicate simultaneously with at least two transceivers to guarantee stable adequate infrared signal transmission.

1.4.3 Infrared service area of digital infrared wireless conference unit

Infrared light is directional invisible light. Infrared wireless conference unit gets best sensitivity when it directly faces a transceiver. Every HCS-5300/80 or

HCS-5380 series digital infrared wireless conference unit is equipped with infrared glass at its frontage to guarantee maximum receiving angle.

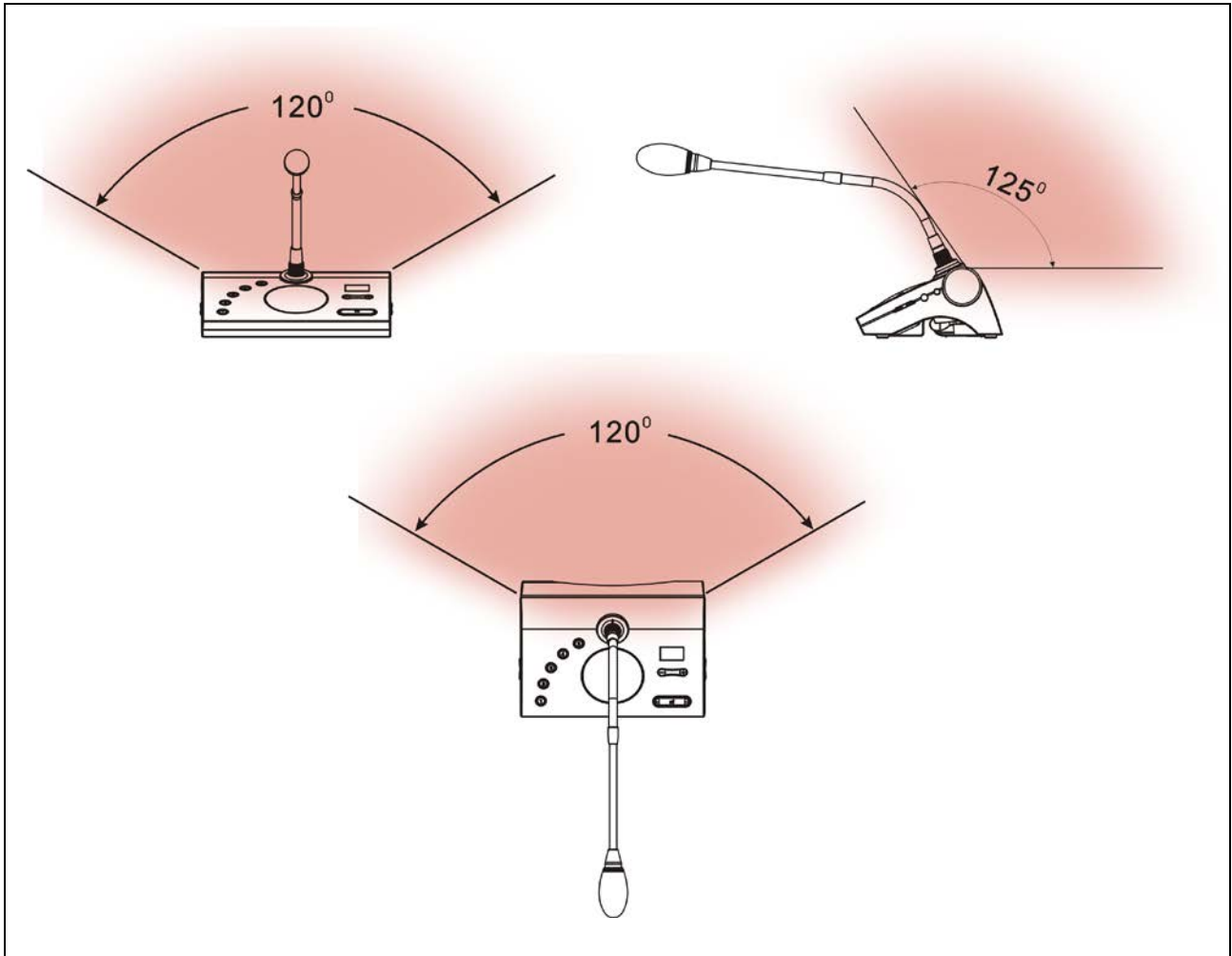

Figure 1.6 Coverage area of digital infrared wireless conference unit

1.4.4 Infrared service area of digital infrared transceiver

The type of the digital infrared transceiver determines the covering area. More transceivers can enlarge the covered area.

The coverage area is determined by the intersection of the infrared working area of the digital infrared transceivers with the receiving plane determined by the

position of the infrared wireless conference unit. The size and the position of the coverage area are related to the height chosen for mounting the transceiver. If infrared signals between the transceiver(s) and the conference unit can get directly to each other, their intensity guarantees normal communication.

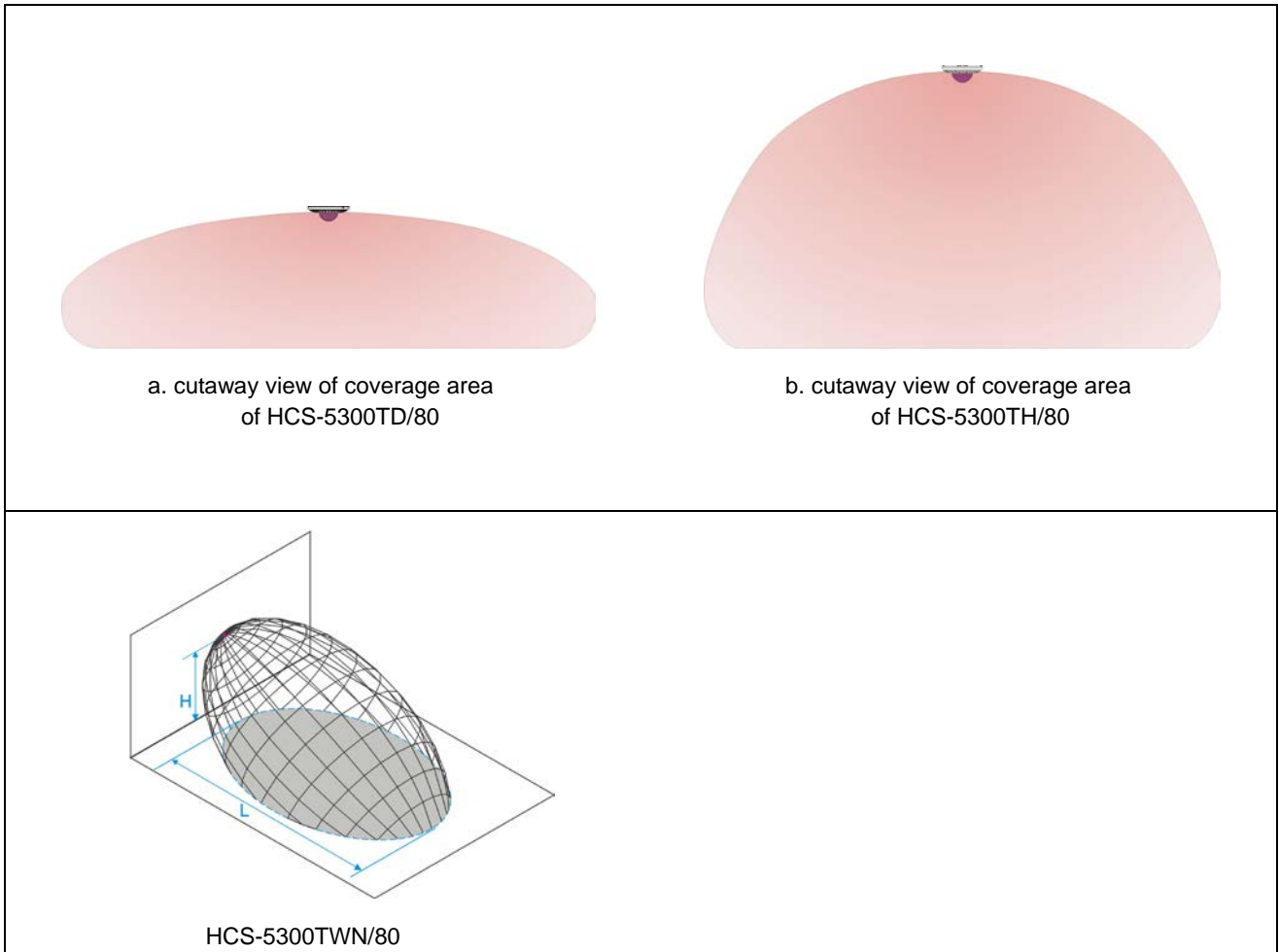

Figure 1.7 Coverage area of digital infrared transceiver

1.4.5 Overlap and multipath effects

If footprints of two transceivers overlap, its total coverage area may be larger than the sum of the two separate footprints. In an area with overlap effect, the individual radiation signals of two transceivers are added, resulting in an increase of the radiation intensity, larger than the required intensity.

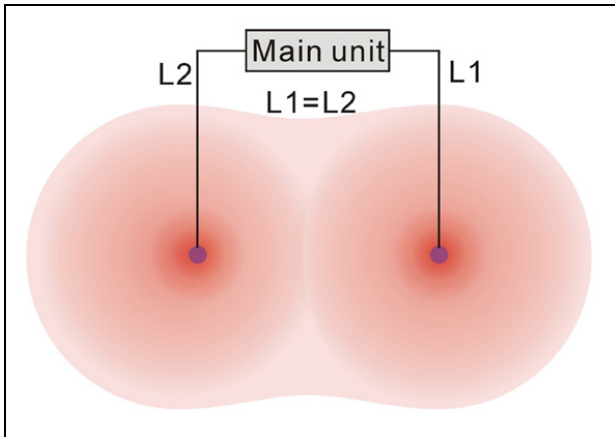

Figure 1.8 Increased coverage area caused by added radiation power

However, due to the differences in the delays of the signals from two or more transceivers, the signals may cancel out each other (multipath effect). In a worst-case situation, loss of reception at some positions (black spots) may be the consequence.

The distance between the main unit and each transceiver must be equivalent to avoid multipath effect.

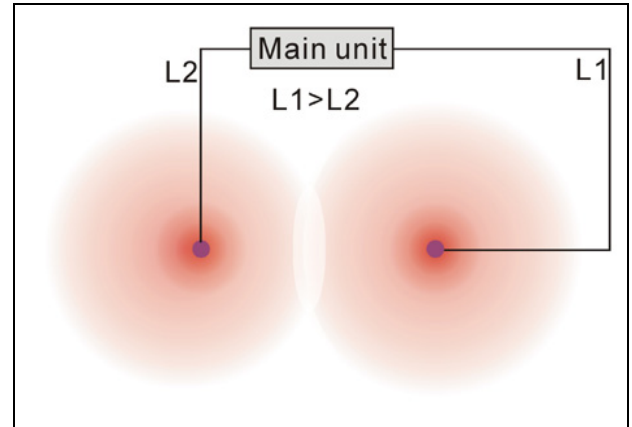

Figure 1.9 Reduced coverage area caused by differences in cable signal delay

Chapter 2 HCS-5300M/80A Series Digital IR Wireless Conference System Main Unit

2.1 Overview

HCS-5300M/80A digital infrared wireless conference system main unit is the heart of the HCS-5300/80 wireless conference system. The main unit can be connected to digital infrared transceivers and recording devices and:

- ◇ display system function configuration
- ◇ display system status
- ◇ fulfill automatic conference controlling

It can be directly connected to a HCS-5100Plus digital infrared language distribution system. If PC software is operated, additional powerful functions are available.

Each HCS-5300MA/MB/80A main unit can be connected to 10 transceivers and each HCS-5300MC/80A main unit can be connected to 6 transceivers at most. The maximal number of wireless conference units is 1000. With connecting to the HCS-8300MES extension unit, the maximal number of wired conference units is 200. Four microphones of digital infrared wireless conference units can be switched on at the same time.

Wired Congress Unit and Interpreter Units can be connected to implement 1+3 CHs wired simultaneous interpretation system, and interpreter Units can be connected to implement 1+7 CHs wireless simultaneous interpretation system.

HCS-5300M/80A is suitable for either tabletop or 19-inch rack mounting using.

Types:

HCS-5300MA/80A

Digital IR Wireless Conference System Main Unit (discussion, voting, 1+7 CHs, with interface for HCS-4100/50 series Wired Congress Unit and Interpreter Unit, Dante interface)

HCS-5300MB/80A

Digital IR Wireless Conference System Main Unit (discussion, 1+7 CHs, with interface for HCS-4100/50 series Wired Congress Unit and Interpreter Unit)

HCS-5300MC/80A

Digital IR Wireless Conference System Main Unit (discussion)

2.2 Functions and indications

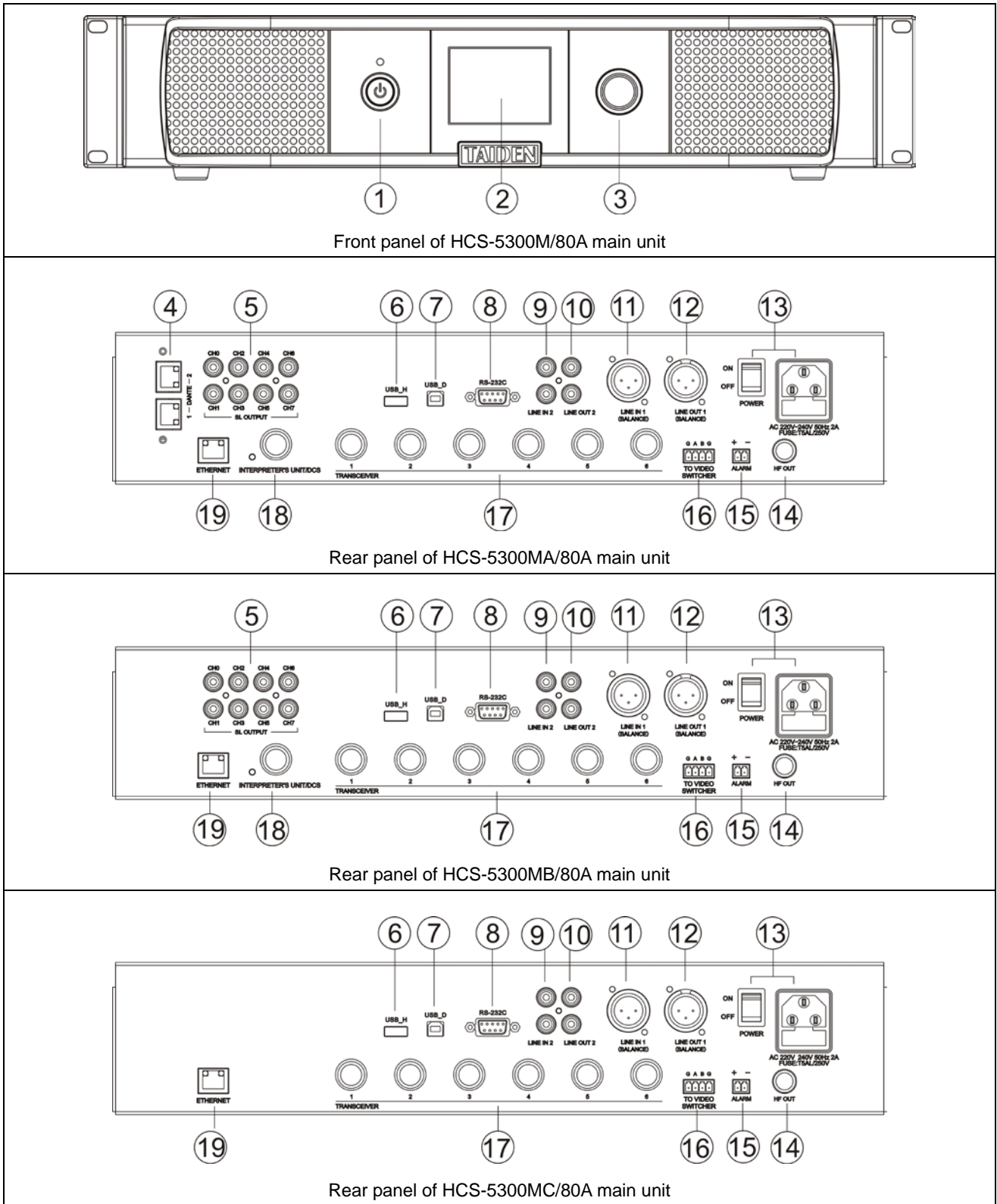

Figure 2.1 Digital infrared wireless conference system main unit

1. Standby key

2. Menu display

- 2.8" LCD, displays main unit status and configuration menu.

3. Operation knob

- For LCD menu operation;

4. Dante interface

- Connecting the conference main unit to the Dante network to transmit audio signals.
- Primary port: Dante2.

5. Simultaneous interpretation outputs (0-7)

6. A type USB interface

- To plug-in a USB stick.

7. Mini USB interface

- For connecting to PC.

8. RS-232C port

- Used for connecting to a central control system for central controlling, as well as for system diagnosis.

9. "Line IN 2" (RCA)

10. "Line OUT 2" (RCA)

11. "Line IN 1" (3 cord XLR balanced input)

12. "LINE OUT 1" (3 cord XLR balanced output)

13. Power supply interface and button

14. HF out (BNC socket)

- For connecting to HCS-5100T series digital infrared radiator.

15. Fire alarm linked trigger interface

When the Alarm Setting in main menu is on:

- **Connected:** all conference units will be switched off and display "ALARM";
- **Unconnected:** conference units will return to the status preceding "ALARM".

16. Video switch interface

- When cooperating with video switch and dome camera, auto video tracking can be realized;
- Connect to a HCS-3316HDN dome camera.

Note:

☞ When connecting to a HCS-3316HDN dome camera : "A" is connected to the "+" of the camera's RS485 interface, while "B" is connect to the "-" interface; SW1: 1; Baudrate: 9600; Ethernet protocol: PELCO-D).

17. Transceiver interfaces (1-6)

18. Interpreter Unit interface

- For connecting to interpreter unit;
- For connecting to HCS-4100/50 series Wired Congress Unit.

19. Ethernet

- For communication between the conference main unit and the PC under TCP/IP protocol to realize remote controlling; furthermore, it enables remote controlling by wireless touch panel through central control system.

2.3 Installation

HCS-5300M/80A series digital infrared wireless conference system main unit can be fixed in a standard 19-inch cabinet. Put the main unit in the cabinet and fix the four holes up with screws ①.

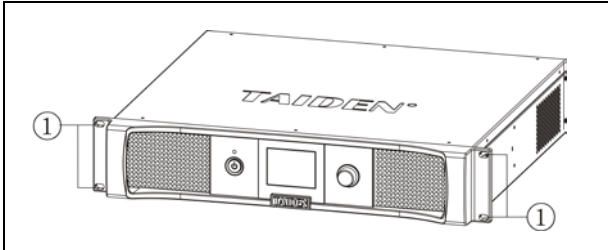

Figure 2.2 Installation of digital infrared wireless conference system main unit

In addition, 1U metal stripes are included as decoration to be installed between the main units in the cabinet. It is also good for the ventilation and cooling off. Fix up the four holes ③ with screws.

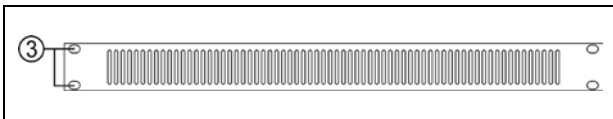

Figure 2.3 Decoration of cabinet

Note:

- ☞ There should be at least 0.5 U of heat dissipation space between the two hosts on the cabinet, not overlapping placement.

2.4 Connection

Several typical system connections of HCS-5300M/80A series main unit will be introduced in this section, including connection:

- To interpretation devices
- To other auxiliary devices
- To HCS-8300MI series
- System connection [Wired/wireless discussion + digital simultaneous interpretation + voting + video tracking]
- System connection [Wired/wireless discussion + digital simultaneous interpretation + video tracking + central control]
- System connection [Wireless discussion + video tracking + central control]

2.4.1 To interpretation devices

HCS-5300MA/MB/80A main unit has embedded 1+7 channels simultaneous interpretation and can be connected to interpretation devices (please refer to [2.5.4](#)). TAIDEN interpreter units can be connected directly to HCS-5300M/80A from interpreter's unit interface and fulfill eight channels simultaneous interpretation (including floor audio).

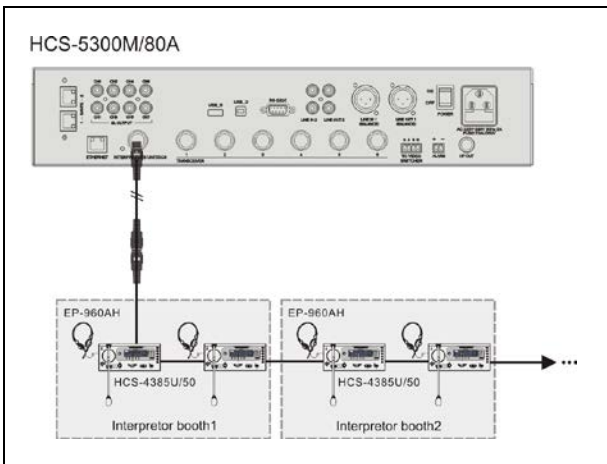

Figure 2.4 Main unit connecting to HCS-4385U/50 through interpreter's unit interface

2.4.2 To other auxiliary devices

2.4.2.1 To external audio device

Digital infrared wireless conference main unit can be connected to an external audio device through LINE IN 1 or LINE IN 2 interface. The external audio signal is now available at the floor audio channel.

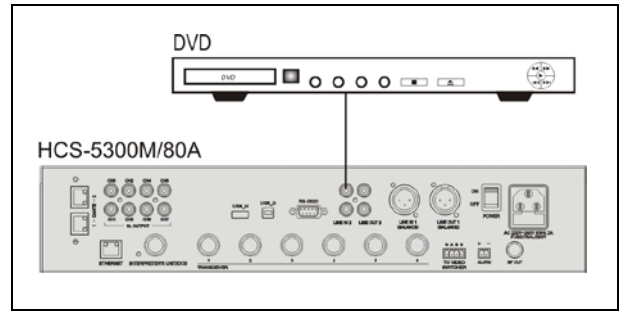

Figure 2.5 Main unit connecting to external audio device through "LINE IN" interface

2.4.2.2 To recording device

HCS-5300M/80A series digital infrared wireless conference main unit has 2 audio outputs and 8 individual audio simultaneous interpretation outputs which can be connected to recording devices. Simultaneous interpretation signals can be recorded or the meeting can be recorded as a sum of all audio signals.

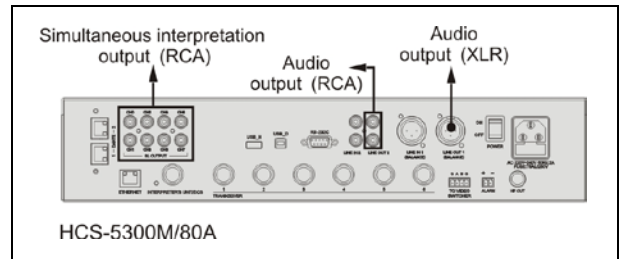

Figure 2.6 Main unit connecting to recording device

2.4.2.3 To PA

HCS-5300M/80A series digital infrared wireless conference system main unit has audio output interfaces which can be connected to a PA system. Use an audio cable to connect “LINE OUT 1” or “LINE OUT 2” of HCS-5300M/80A to the input interface of PA.

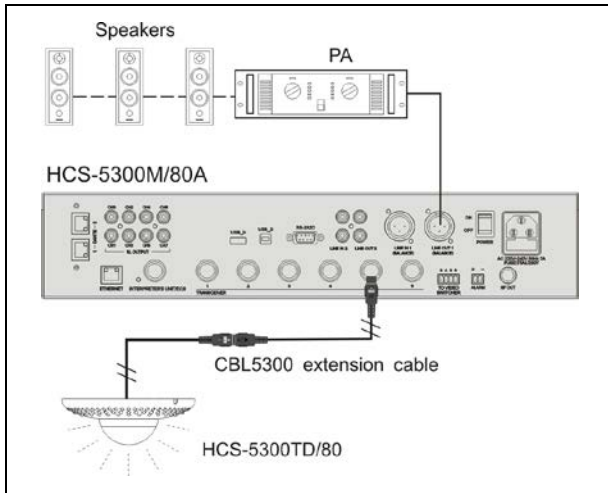

Figure 2.7 Digital infrared wireless conference main unit connecting to PA

2.4.3 To HCS-8300MI series

HCS-5300M/A main unit connect with HCS-8300MI series 8 Channels Audio Input Interface to realize the following function:

a) Transmits 7 digital (AES/EBU)/analog audio channels to the interpretation channels of the Congress System,

for example for remote interpretation purposes or for transmission to floor channel

b) All inputs can be mixed with arbitrary ratio, and outputted to any channel;

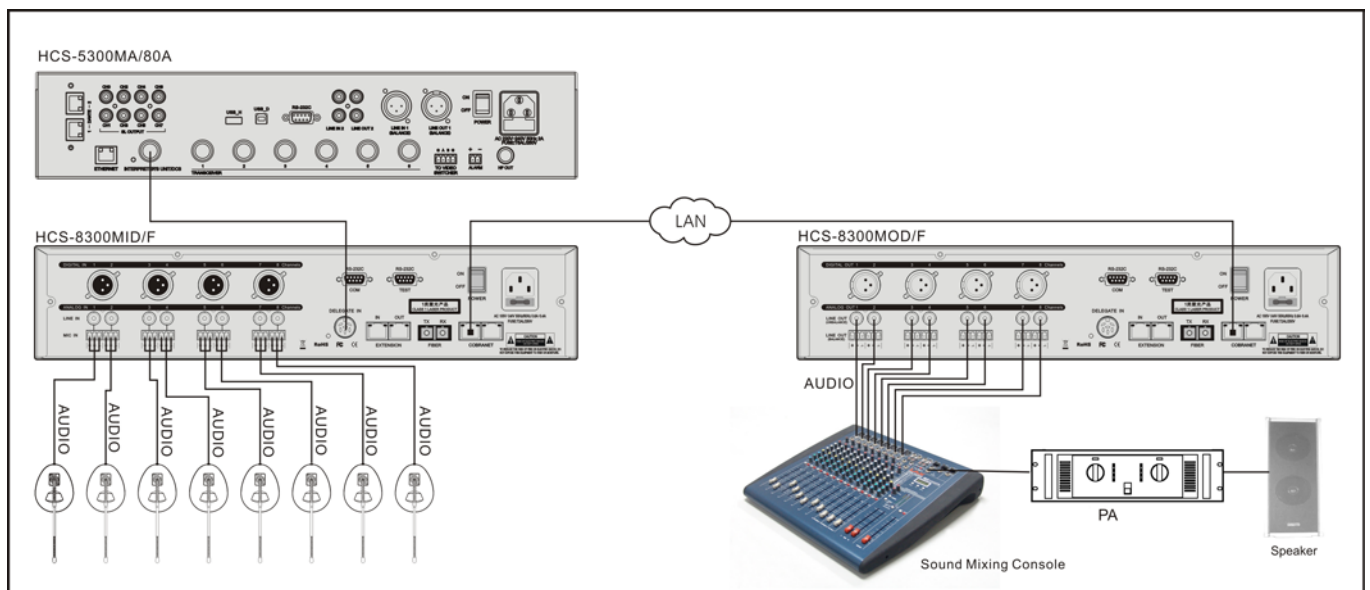

Figure 2.8 HCS-5300M+HCS-8300MI+HCS-8300MO multi-channel digital audio transmission solution

2.4.4 System connection 1

● [Wired/wireless discussion + digital simultaneous interpretation + voting + video tracking]

HCS-5300MA/80A has the functions for discussion, vote and digital simultaneous interpretation. The system can be connected to an automatic video tracking system. For video tracking purposes, the application software is used to make camera presets for every conference unit. If the conference unit is switched on, the video tracking system will automatically find the appropriate preset and focus on the speaker. The view of the speaker will be displayed on large screen or other display devices. The automatic video tracking system is compatible with several kinds of video signals and operates automatic video switching. The video tracking system is composed of video switcher, camera control board and

high-speed dome camera.

Use a RS-485 cable and connect the HCS-5300M/80A main unit (port "TO VIDEO SWITCHER") to the corresponding port at the rear panel of the video switcher (port "TAINET").

Multiform functions can be realized with the following system configuration:

- ◆ Digital infrared wireless conference;
- ◆ Wired/wireless discussion
- ◆ Digital infrared language distribution system;
- ◆ Voting;
- ◆ Video tracking.

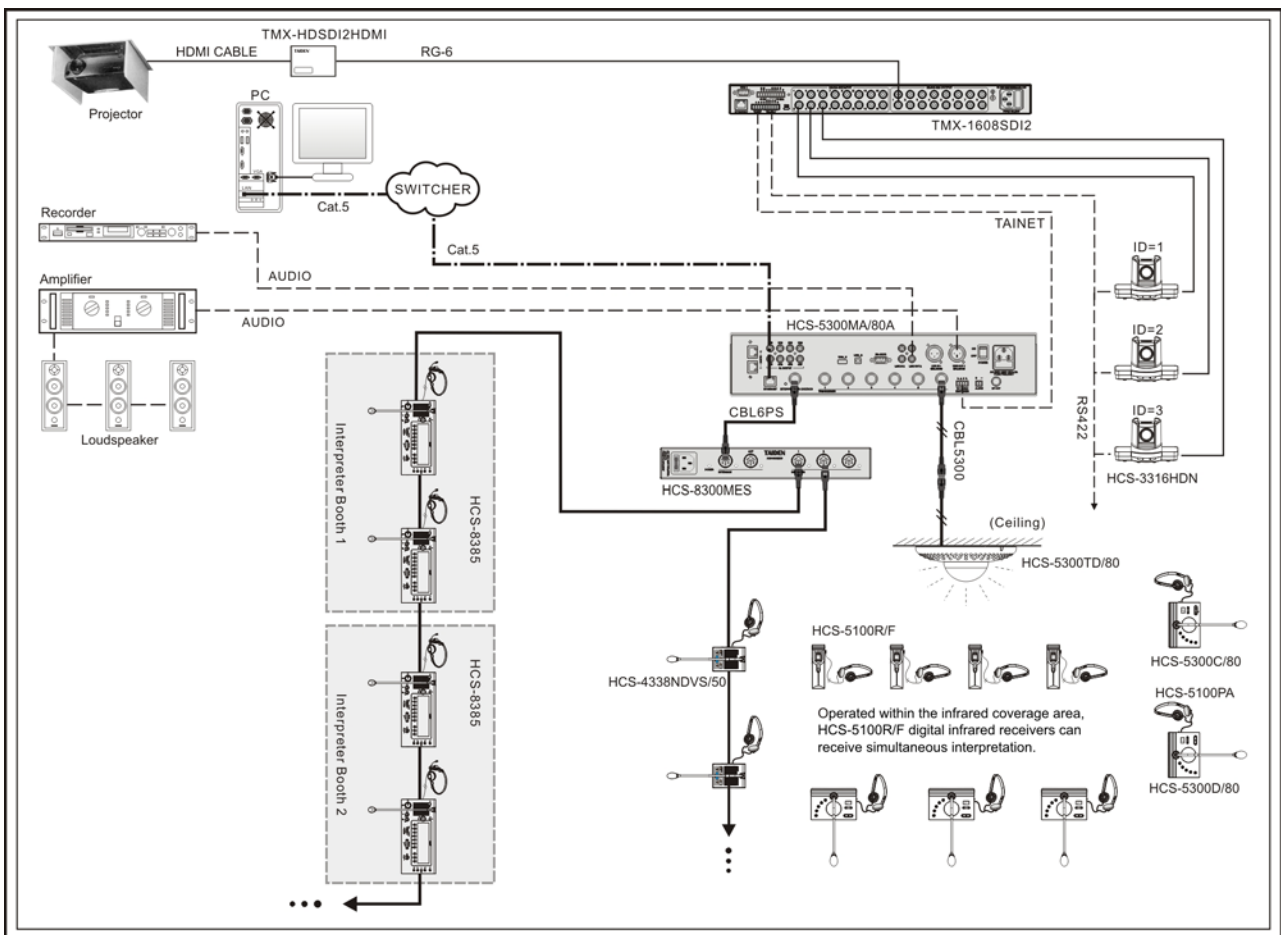

Figure 2.9 System connection [Wired/wireless discussion + digital simultaneous interpretation + voting + video tracking]

2.4.5 System connection 2

● [Wired/wireless discussion + digital simultaneous interpretation + video tracking + central control]

HCS-5300MB/80A has the functions for discussion and digital simultaneous interpretation. The system can be connected to an automatic video tracking system. For video tracking purposes, the application software is used to make camera presets for every conference unit. If the conference unit is switched on, the video tracking system will automatically find the appropriate preset and focus on the speaker. The view of the speaker will be displayed on large screen or other display devices. The automatic video tracking system is compatible with several kinds of video signals and operates automatic video switching. The video tracking system is composed of video switcher, camera control board and high-speed dome camera.

Use a RS-485 cable and connect HCS-5300M/80 Main unit (port "TO VIDEO SWITCHER") to the corresponding port at the rear panel of the video switcher (port "TAINET").

Also, TAIDEN HCS-5300 digital infrared wireless conference system and TAIDEN HCS-6100 network central control system can be joined together seamlessly. It can link together various devices, hardware and environment equipment from different manufacturers. The central control system can operate the conferencing devices through wired Ethernet or

wireless bidirectional communication by wired/wireless touch panel. Features include power controlling, environment light adjustment and on-off, electric curtain or projector screen open-close and on-off, system PA volume controlling and controlling various electric devices, such as DVD, VCR, TV, projector, etc. RS-232C or RS-485 interfaces are available. Remote controlling, even from distant places, can be achieved through LAN or internet.

If using TAIDEN network central control system touch panel to control conference units, the ID of each conference unit should be known (have been set up before leaving factory, ID will be displayed on LCD on startup).

Multiform functions can be realized with the following system configuration:

- ◆ Digital infrared wireless conference;
- ◆ Switch on/off microphone of conference unit;
- ◆ Wired /wireless discussion
- ◆ Digital infrared language distribution system;
- ◆ Video tracking, and cameras can be remote controlled;
- ◆ Central controlling to currently connected devices.

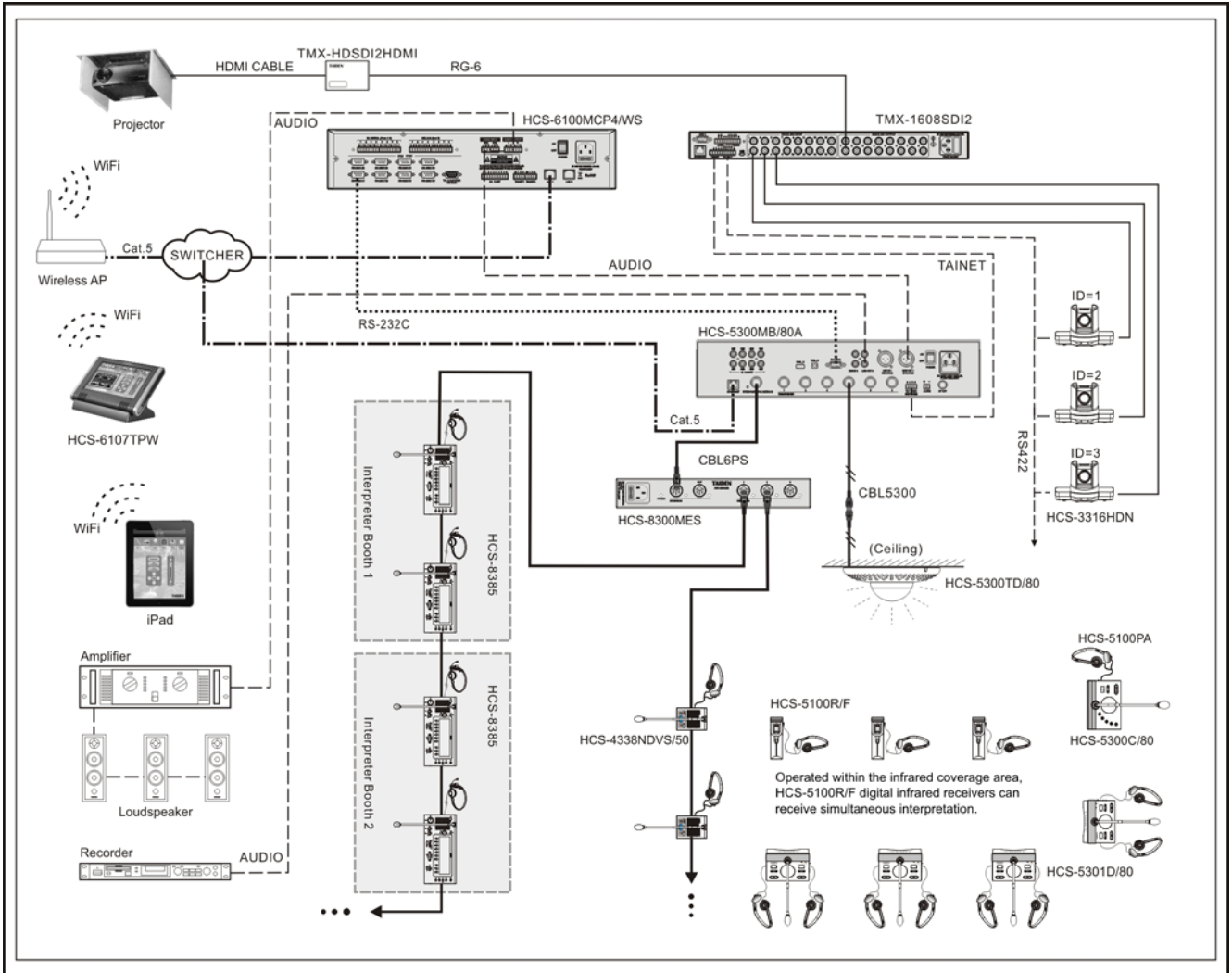

Figure 2.10 System connection [Wired/wireless discussion + digital simultaneous interpretation + video tracking + central control]

2.4.6 System connection 3

● [Wireless discussion + video tracking + central control]

HCS-5300MC/80A has the functions for discussion. The system can be connected to an automatic video tracking system. For video tracking purposes, the application software is used to make camera presets for every conference unit. If the conference unit is switched on, the video tracking system will automatically find the appropriate preset and focus on the speaker. The view of the speaker will be displayed on large screen or other display devices. The automatic video tracking system is compatible with several kinds of video signals and operates automatic video switching. The video tracking system is composed of video switcher, camera control board and high-speed dome camera.

Use a RS-485 cable and connect HCS-5300M/80 Main unit (port "TO VIDEO SWITCHER") to the corresponding port at the rear panel of the video switcher (port "TAINET").

Also, TAIDEN HCS-5300/80 new generation digital infrared wireless conference system and TAIDEN HCS-6100 network central control system can be joined together seamlessly. It can link together various devices, hardware and environment equipment from different manufacturers. The central control system can operate the conferencing devices through wired Ethernet or

wireless bidirectional communication by wired/wireless touch panel. Features include power controlling, environment light adjustment and on-off, electric curtain or projector screen open-close and on-off, system PA volume controlling and controlling various electric devices, such as DVD, VCR, TV, projector, etc. RS-232C or RS-485 interfaces are available. Remote controlling, even from distant places, can be achieved through LAN or internet.

If using TAIDEN intelligent central control system touch panel to control conference units, the ID of each conference unit should be known (have been set up before leaving factory, ID will be displayed on LCD on startup).

Multiform functions can be realized with the following system configuration:

- ◆ Digital infrared wireless conference;
- ◆ Switch on/off microphone of conference unit;
- ◆ Video tracking, and cameras can be remote controlled;
- ◆ Central controlling to currently connected devices.

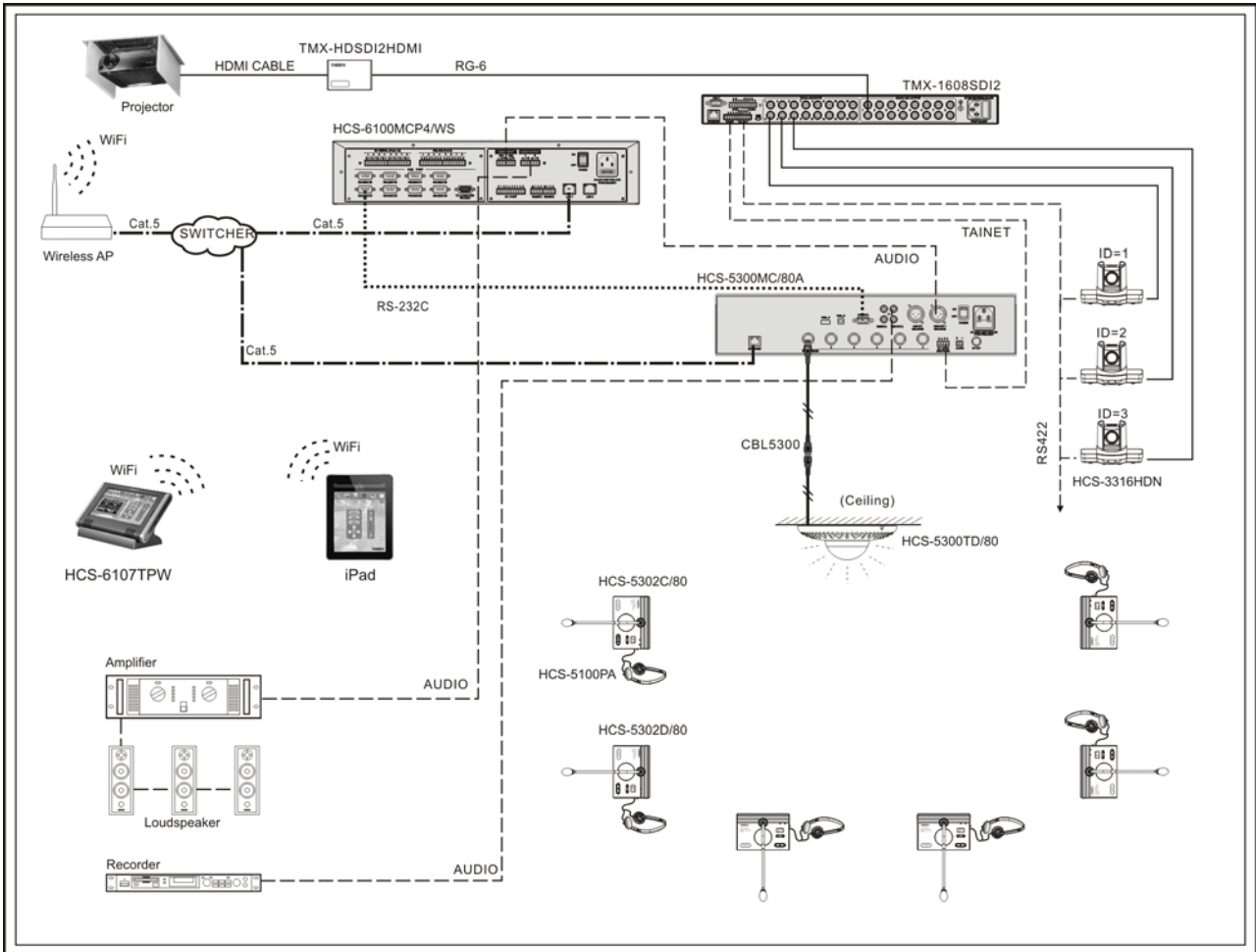

Figure 2.11 System connection [Wireless discussion + video tracking + central control]

2.4.7 Load capacity

HCS-5300MA/MB/80A main unit can connect to and power for digital infrared wireless transceiver, wired congress unit and interpretation unit. So, devices type and quantity must be considered synthetically when designing a system.

- ◆ The HCS-5300M/80A main unit can connect to 10 transceivers at most. We advice to connect other wired units via a HCS-8300MES extension unit.
- ◆ The HCS-5300M/80A main unit can connect to 14 interpretation units at most. At this point, only 6 transceivers can be supported, if you want to connect more transceivers, please connect them via a HCS-5300MX.

The maximal number of wired units that can be directly connected to the HCS-5300M/80A with 6 transceivers is shown in table 2.1, as a reference of system configuration:

Table2.1 Quick lookup table for the max. number of wired units (unit: pcs)

System status	Type No.	The extension cable length between the CMU and the first wired unit connected to the socket		
		20 m	40 m	60 m
HCS-5300MA/MB/80A+ HCS-5300T/80 × 6	HCS-4338N/50	18	17	16
	HCS-4385U/50	14	14	11
	HCS-8385	13	10	8
	HCS-4385U/50+ HCS-8336	8+4	6+3	4+2
	HCS-8385+ HCS-8336	8+4	6+3	4+2

2.5 Configuration and operation

Digital infrared wireless conference system main unit can be configured and set up through menu operation with four buttons. All menu items operation will be introduced one by one in this section.

A) Starting initialization

Switch on and press the standby key, the HCS-5300M/80A digital infrared wireless conference system main unit will start initialization:

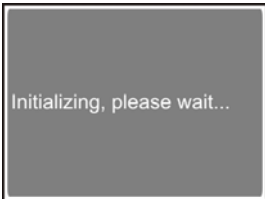

Under the initial interface, there are parameters such as speaker volume, operation mode, active micro's number, audio mode and IP address about current main unit. Rotate the operation knob can adjust the volume of speakers, range: -30 to 0 dB.



B) Access main menu

Pressing the operation knob under initial interface will go to main menu, which includes the following items:

Audio Mode Setting	Operation
Max. Active Mics	System status
SI Setting	Line In 1 Setting
Line In 2 Setting	Headphone Auto Att.
Ring Setting	Chairman Priority
Mic. Parameters	Mic. Auto Off
Language	Network Setting
Time Setting	Video Tracking
Mute Speaker	Alarm Setting
Backup/Restore	Voice Mode Setting
WiredMic Function	Number
Mic. IR Strength	Mic. Led Setting
USB Audio Setting	License
Dante Audio Mode	RS-232 Baudrate
Noise Elimination	Line out1 Noise Gate
Retractable Mic.	Interp. Outgoing
Interp. Unit LED	Voice of God Setting
One Touch Turn On	Floor From MI SI
Screensaver	About
About Dante	Return

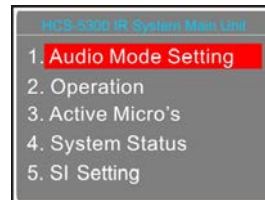

- Press the operation knob to go to the corresponding submenus;
- To switch from term to rotate the operation knob.

2.5.1 Audio Mode Setting

“Audio Mode” includes three submenus: “Normal”, “Remote Conferencing” and “External Process”.

- **Normal:** LineOut1/2 and floor audio output feature each the sum signal of Dante In + LineIn1 + LineIn2 + active microphones (figure 2.12);

- **Remote Conferencing:**

If selecting the analog interface for far end: **A)** LineOut1 output features the sum signal of Dante In + LineIn2 + active microphones; **B)** LineOut2 and floor audio output feature each the sum signal of Dante In + LineIn1 + LineIn2 + active microphone signals (figure 2.13).

If selecting the Dante interface for far end, **C)** LineOut1 output feature the sum signal of Dante In2 + LineIn1 + LineIn2 + active microphones; **D)** LineOut2 and floor audio output feature each the sum signal of Dante In + LineIn1 + LineIn2 + active microphones (figure 2.14);

- **External Process:** If selecting analog interface for external processor, LineOut1 and LineOut2 output feature each the sum signal of Dante In + LineIn2 + active microphones; floor audio output features the audio signal of LineIn1 (figure 2.15).

If selecting Dante interface for external processor, LineOut1/2 output feature each the sum signal of Dante In2 + LineIn1 + LineIn2 + active microphones; floor audio output featured the audio signal of Dante In1 (figure 2.16).

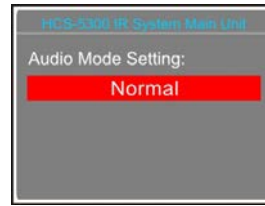

Rotate the operation knob to select audio mode;

- **When selecting “Normal” mode:** Press the knob to save and return to the upper level menu.
- **When selecting “Remote Conferencing” mode or “External Process” mode:** Press the knob to enter the audio interface selection interface:

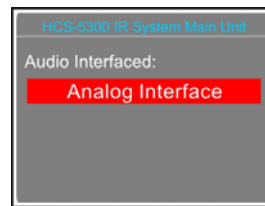

1. Rotate the operation knob to select an audio port;
2. Press the knob to save and return to the upper level menu.

Note:

☞ Only the main unit with Dante mould has Dante In and Dante interface.

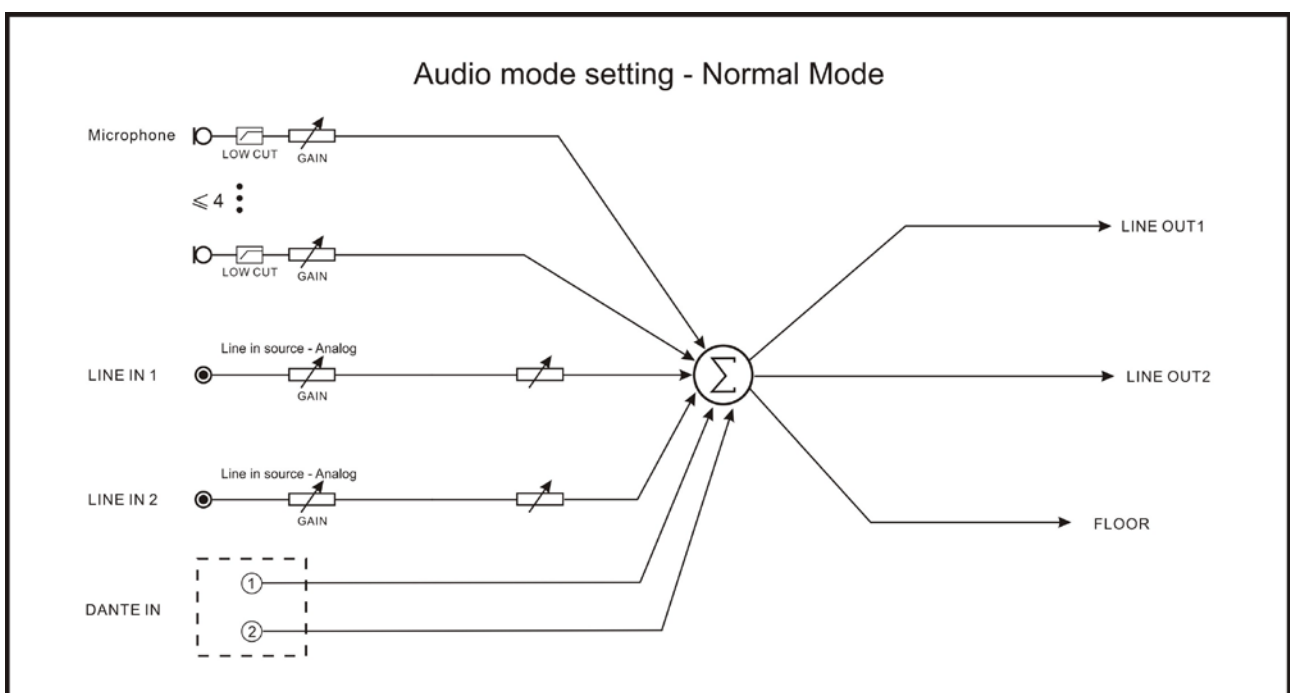

Figure 2.12 Audio mode setting – Normal Mode

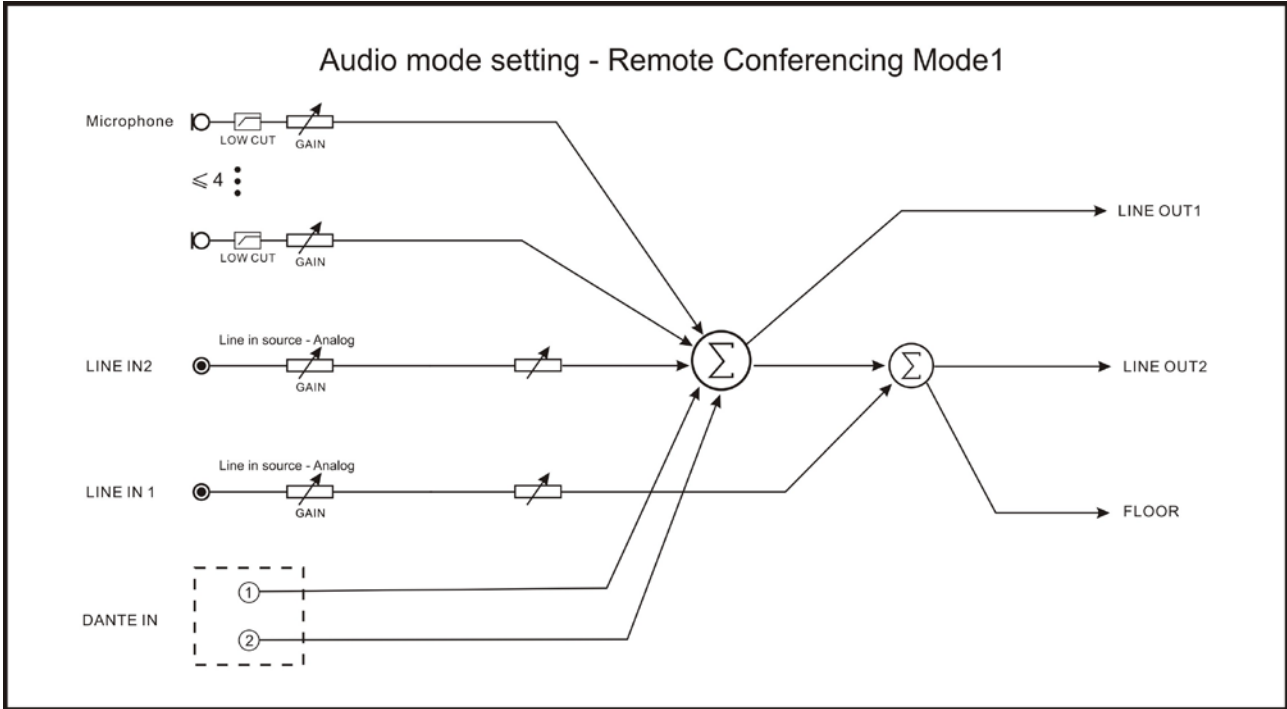

Figure 2.13 Audio mode setting – Remote Conferencing Mode1

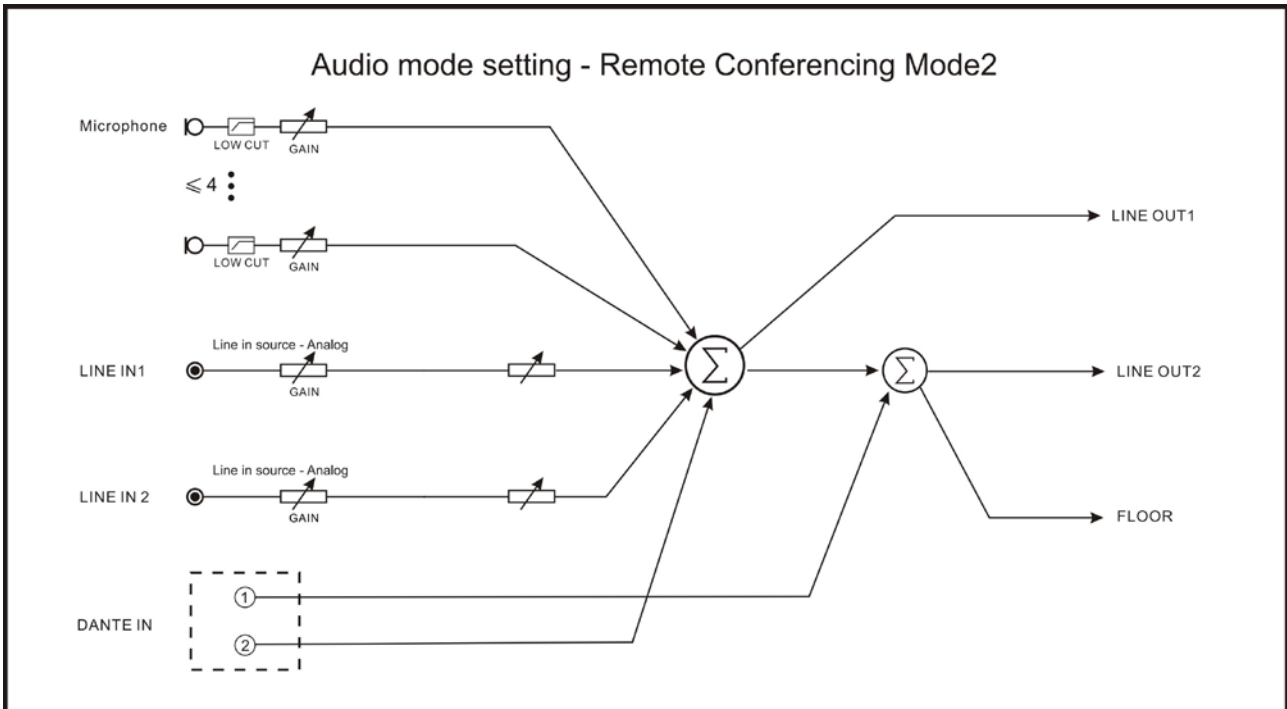

Figure 2.14 Audio mode setting – Remote Conferencing Mode2

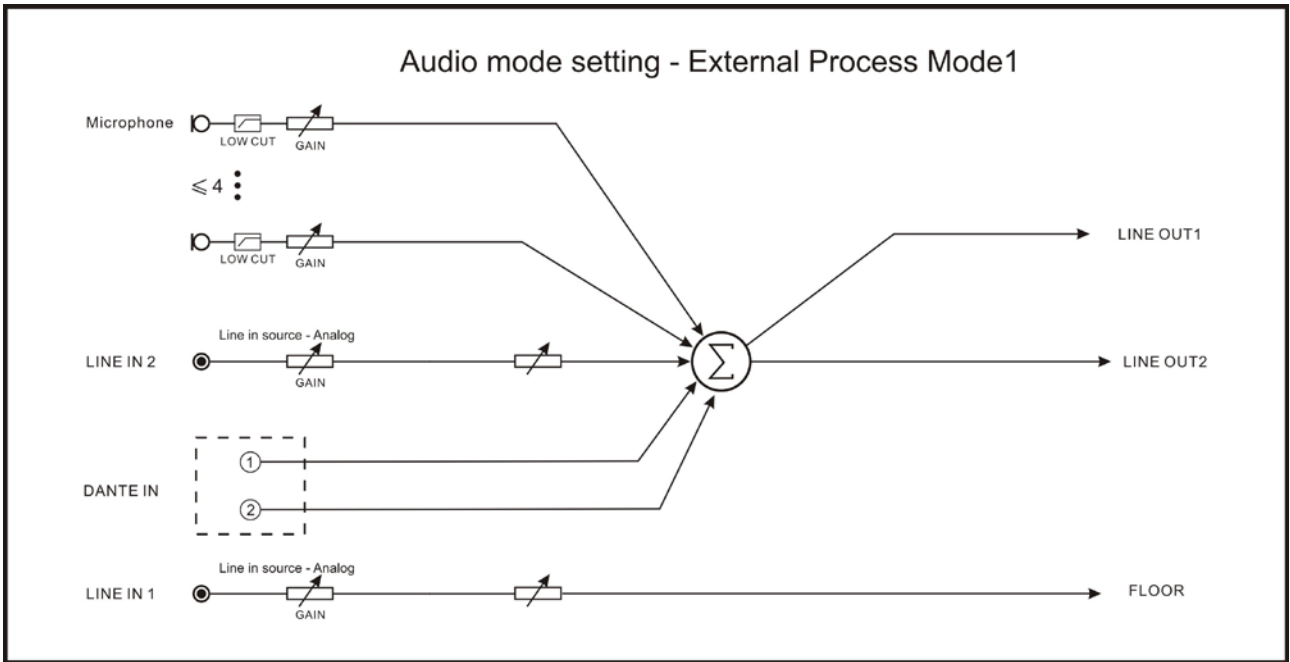

Figure 2.15 Audio mode setting – External Process Mode1

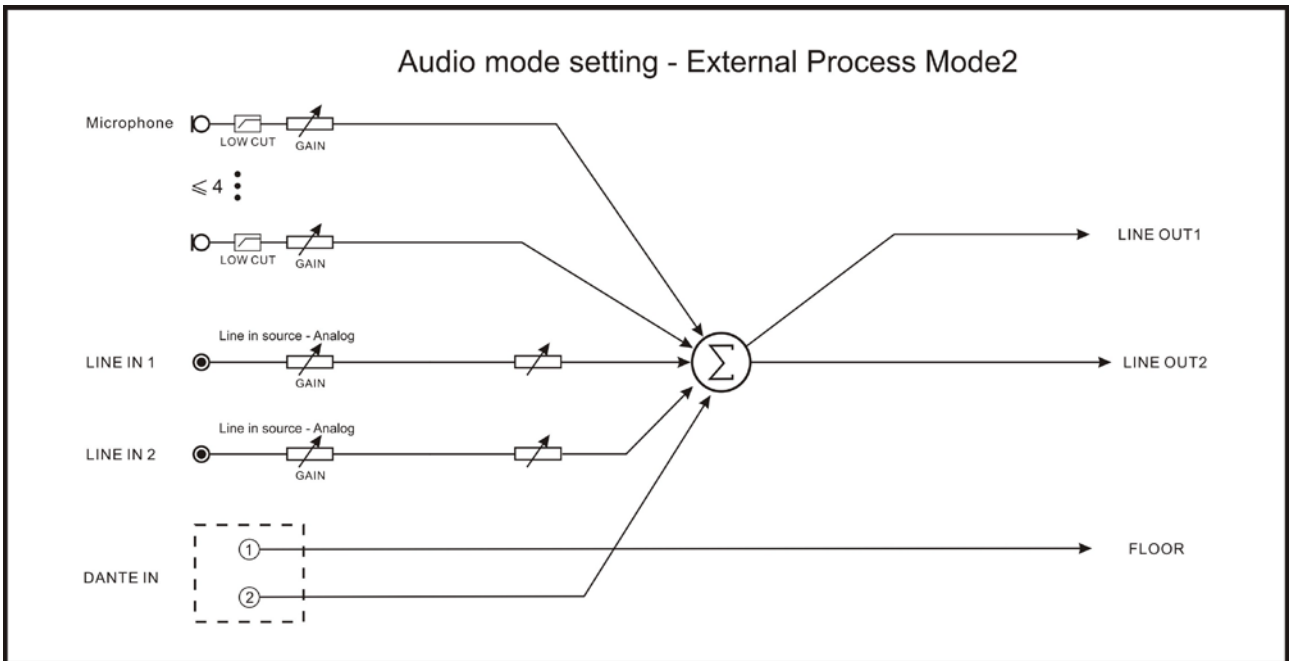
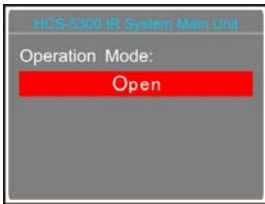

Figure 2.16 Audio mode setting – External Process Mode2

2.5.2 Operation

Rotate the operation knob to switch microphone mode among “Open”, “Override” and “Voice”.



■ “Open”:

If the maximal number of active microphones (including VIP/chairman unit), previously fixed, has been reached, a further delegate unit cannot be activated; and the VIP/chairman unit still can be activated when the total number of active microphone is less than 4 in the system.

■ “Override”:

If the maximal number of active microphones has been reached and if another delegate unit is activated, the delegate unit switched on first will be switched off first automatically (first in / first out). If the total number of active microphone is less than 4 in the system, the VIP/chairman unit can be activated till the number reaches 4 and then if another chairman unit is activated, the unit switched on first will be switched off first automatically (primarily switched off the delegate units and then the VIP/chairman units).

■ “Voice”:

When delegates speak into the microphones at a short distance, the microphones will be activated. If the maximal number of active microphones, previously fixed, has been reached, other delegate units cannot be activated; and the VIP/chairman unit still can be activated when the total number of active microphone is less than 4 in the system.

2.5.3 Active Micro's

Rotate the operation knob to select the maximal number of active microphone and then press the operation knob to save and return to the upper level menu.

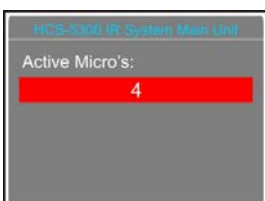

2.5.4 System Status

Rotate the operation knob to select “Carrier Using Status” and press the knob to confirm.

The status of every channel and the status of the active microphone(s) and their batteries will be displayed.



Carrier	ID	Signal	Battery
4.3M	2	M	75%
4.8M			
5.8M	4	H	100%
6.3M			

The example figures IR wireless conference units with ID “2” and “4” are speaking and their carriers are “4.3M” and “5.8M”(the carrier of wired microphone is Wired), and their signal intensities are “M” (middle) and “H” (high). “L” means the signal is low and “X” means there is no signal received. Two more channels are available. The signal will be null when “Mic. IR Strength” is set “No”.

2.5.5 SI Setting

In “SI Setting” submenu, the following parameters need to be set up:

- ◆ “Number of Channel(s)”
- ◆ “Language for Channel”
- ◆ “Number of Booth(s)”
- ◆ “Interlock mode between booths”
- ◆ “Language for Booth”
- ◆ “Distribute Floor to Used SI Channel”
- ◆ “Interpreter Units Display Real Time”

a) Select Number of Channel(s)



Rotate the operation knob to switch between 0-7;

Note:

☞ If there are wired conference units connected, the maximal number of channels is 3.

- ◆ If “0” is selected, it stands for no SI function, press the operation knob to save and return to the main menu;
- ◆ If other values are selected, it stands for the number of interpretation channels, press the operation knob to

go to step b).

b) Select Language of Channel



Rotate the operation knob to select a channel and then press the knob to set up: rotate the knob to select a language and then press the knob to confirm. Repeat the step to set up all language.

- ◆ Select "Exit" to return to the main menu;
- ◆ Select "Next" to go to step c);

c) Select Number of Booth(s)

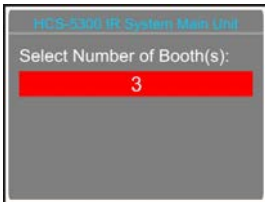

Rotate the operation knob to switch between 0-7. Usually, one language will take one booth.

- ◆ If "0" is selected, it stands for no interpreter booth, press the knob to save and return to the main menu;
- ◆ If other values are selected, it stands for the quantity of interpreter booths, press the knob to go to step d).

d). Interlock mode between booths

Select interlock mode between booths, includes:

- "OVERRIDE"
- "OVERRIDE-BC"
- "INTERLOCK"

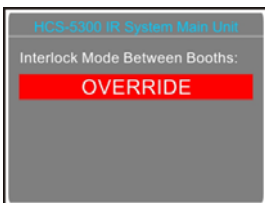

- 1). Rotate the operation knob to switch among the three interlock modes;
 - "INTERLOCK" mode prevents that two booths engage the same channel. when an interpreter unit in another booth to override an occupied channel in another booth, the "Microphone ON" indicators the occupied channel will flash on the control panel for about 5 seconds.
 - "OVERRIDE" mode enables an interpreter unit

in another booth to override an occupied channel in another booth, but supplying the same channel.

- "OVERRIDE-BC" mode enables A/B/C channel of an interpreter unit in another booth to override an occupied B/C channel in another booth, but supplying the same channel; when an interpreter unit in another booth to override an occupied A channel in another booth, the "Microphone ON" indicators the occupied A channel will flash on the control panel for about 5 seconds.

- 2). Press the operation knob to confirm selected interlock mode and go to step e).

e) Select Language for Booth

To distribute interpretation languages separately, A/B/C channels are provided in each Interpreter unit. The language setting of A/B/C channels for all Interpreter units in one booth is uniform. After setup of booth numbers, the user interface to set up output channel A/B/C language will show for each booth.

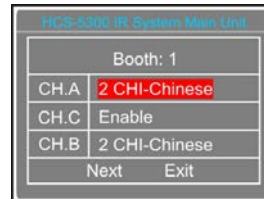

- 1). Rotate the operation knob to select a language from those languages that have been selected in step b) and press the knob to confirm;
- 2). Select channel C language for booth 1: "Enable" or "Disable";
 - ◆ If "Enable" is selected for C then use the operation knob to select a language for B from those languages that have been selected in step b) and press the knob to confirm;
 - ◆ If "Disable" is selected for C then select channel B language from "Disable" or "Enable";
 - "Disable" stands for no language output from channel B;
 - "Enable" stands for the language of channel B which can be any of the selected languages.
- 3). Repeat 1)-2) to set up output channel A/B/C language for all booths and then go to step f).

f) Distribute Floor to Used SI Channel

Enable/disable switch to floor channel automatically when no interpretation channel is available.



- 1). Rotate the operation knob to select “Yes” or “No”;
- 2). Press the knob to save and then go to step g).

g) Interpreter Units Display Real Time

Select to display real time or not on the LCD screen of interpreter units.

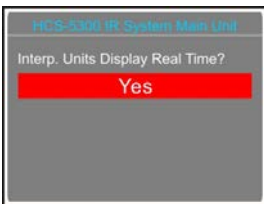

- 1). Rotate the operation knob to select “Yes” or “No”;
- 2). Press the knob to save and return to the upper level menu.

2.5.6 Line In 1 Setting

Adjust Line In 1 volume, range: Mute, -29 dB - 0 dB.

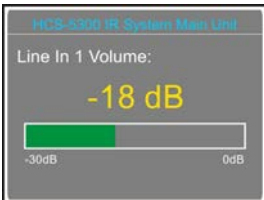

- a). Rotate the operation knob to adjust volume;
- b). Press the knob to save and return to the upper level menu.

2.5.7 Line In 2 Setting

Adjust Line In 2 volume, range: Mute, -29 dB - 0 dB.

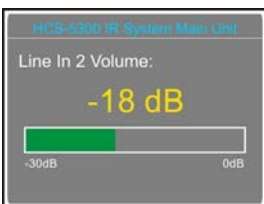

- c). Rotate the operation knob to adjust volume;
- d). Press the knob to save and return to the upper level menu.

2.5.8 Headphone Auto Att.

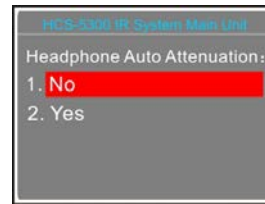

If a headphone is plugged, howling may happen when the microphone is activated. “Headphone Auto Att.” function is used to suppress howling for floor language channel. If enabled, the headphone audio signal will decrease automatically by 12 dB.

- a). Rotate the operation knob to select “Yes” or “No”;
- b). Press the knob to save and return to the upper level menu.

2.5.9 Ring Setting

Select ring tone on/off on request to speak, when chairman priority button is pressed or when timing speech.

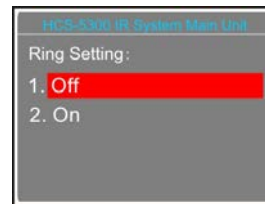

- a). Rotate the operation knob to select ring on/off;
- b). Press the knob to save and return to the upper level menu.

2.5.10 Chairman Priority

Priority includes two priority modes: “All mute”
“All off”



- a). Rotate the operation knob to select priority mode between “All Mute” and “All Off”;
- b). Press the knob to save and return to the upper level menu.
 - “All Mute”: when the chairman presses and holds the “Priority” button, all active microphones will mute temporarily; when the chairman releases the “Priority” button, all temporarily muted

microphones will resume.

- “All Off”: when the chairman presses the “Priority” button, all active microphones will be deactivated.

2.5.11 Mic. Parameters



1. “Mic. Gain Setting”

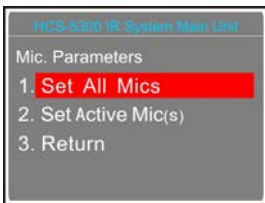

- Rotate the operation knob to select “Set All Mics” or “Set Active Mic(s)”;
- Press the knob to go to the next step.

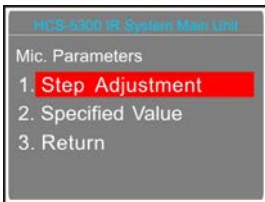

▪ “Specified Value



- Rotate the operation knob to adjust the gain of all/ active microphones, range: -12 dB - 12 dB;
- Press the knob to save.

▪ “Step Adjustment” (unsuitable for wired units)

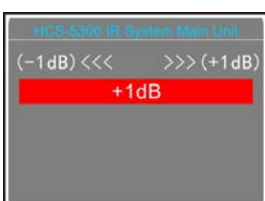

- Rotate the operation knob to reduce/increase 1dB of the gain, range: -12 dB - 12 dB;
- Press the knob to save and return to the upper level menu.

2. “Mic. Low Cut Setting”



- Rotate the operation knob to select “On” or “Off”;
- Press the knob to save and return to the upper level menu.

2.5.12 Mic. Auto Off



Use operation knob to enable/disable to turn off the microphone automatically after a period of silence.

- “Yes”: the microphone will automatically switch off after a period of silence and the period shall be set up as below:

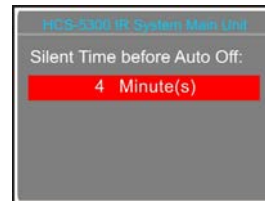

- Set up the period in minutes with the operation knob, range from 1-59 minute(s);
- Press the knob to save and return to the upper level menu.

- “No”: do not switch off the microphone after a period of silence, and return to the upper level menu.

Note:

☞ Microphone Auto Off Setting is invalid for wired microphones.

2.5.13 Language



- Rotate the operation knob to switch language from “中_简”, “中_繁”, “English”;
- Press the knob to confirm and return to the upper level menu.

2.5.14 Network Setting

“Network Setting” includes three submenus:

- “IP address”
- “Subnet mask”
- “Gateway”

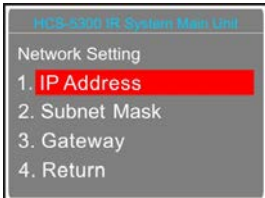

a) Setting up unique “IP Address” for the main unit:

- Select the “IP address” and press the operation knob to go to set up the IP address interface:



- Rotate the knob to switch between the four numbers;
- Press the knob to edit the selected number;
- Rotate the knob to adjust the number;
- Press the knob to save;
- Select “Return” to return to the high level menu.

b) Setup “Subnet Mask” and “Gateway”

The same chronological order as for the “IP address” set up.

Note:

- ☞ “IP address”, “Subnet Mask” and “Gateway” of the system software must correspond with the above main unit settings, otherwise connection error will occur.

2.5.15 Time Setting



- Rotate the knob to switch between the four numbers;
- Press the knob to edit the selected number;
- Rotate the knob to adjust the number;
- Press the knob to save;
- Select “Return” to return to the high level menu.

2.5.16 Video Tracking

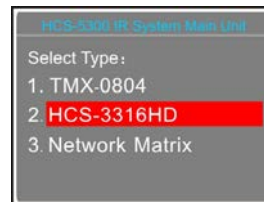

- Rotate the operation knob to select a connection type (HCS-3316HD, TMX-0804, Network Matrix) according to current system;

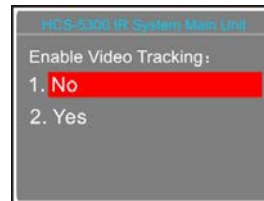

- Rotate the knob to select “Yes” or “No”;
 - If “No” is selected, the video tracking function is disabled;
 - If “Yes” is selected, the video tracking function is enabled;
- Press the knob to save and return to the upper level menu;
- Reboot the main unit to effect.

2.5.17 Mute Speaker

Set work mode between loudspeaker and headphone.

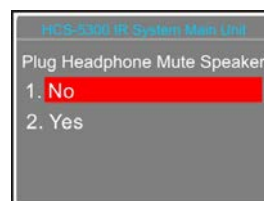

- Rotate the operation knob to select “Yes” or “No”;

- If “Yes” is selected, the loudspeaker is muted when the headphone is plugged;
- If “No” is selected, the loudspeaker and the headphone can work at the same time, the loudspeaker sends out the floor channel only and the headphone sends out the floor channel and SI channels;

Note:
 ☞ The loudspeaker will be muted when plugging all the two headphones of HCS-5301/80, HCS-5380DDS or HCS-4338NDDS/50 even if selected “No”.

- b) Press the knob to save and return to the upper level menu.

2.5.18 Alarm Setting

Enable/disable alarm function.

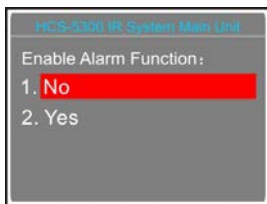

- a) Rotate the operation knob to select “Yes” or “No”;
 b) Press the knob to save and return to the upper level menu.

2.5.19 Backup/Restore

The system parameters can be backed up or restored through the front panel USB port. Make sure that the USB disk is properly connected, otherwise it will prompt “Please insert the USB disk.”



- a). Rotate the operation knob to select “Backup” or “Restore”;
- If “Backup” is selected, system parameters can be backed up;
 - If “Restore” is selected, system parameters can be restored;
- b). Press the knob to confirm and to go to selected menu item;

- c). Return to the upper level menu after backup or reboot the main unit after recovery to save the parameters.

2.5.20 Voice Mode Setting

“Voice Mode Setting” includes two submenus:

“Auto Off Time”

“Voice Sensitivity”

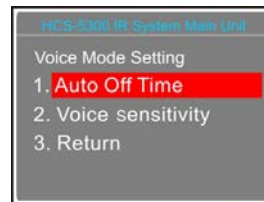

■ “Auto Off Time”

- a). Rotate the operation knob to select “Auto Off Time” and press the knob to enter the setup interface, rotate the knob to select for “3s”, “5s” or “10s”, shown in the following figure:



- b). Press the knob to save and return to the upper level menu.

■ “Voice Sensitivity”

- a). Rotate the operation knob to select “Voice Sensitivity” and press the knob to enter the setup interface. Rotate the knob to select the “High”, “Middle” or “Low”, shown as in the following figure:

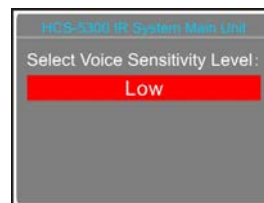

- b). Press the knob to save and return to the upper level menu.

2.5.21 WiredMic Function

Enable/disable WiredMic function.



- Rotate the operation knob to select “Yes” or “No”;
- Press the knob to save and reboot the main unit to enable.

Note:

☞ System only supports 1+3 S.I. channels when connecting to wired microphones.

2.5.22 Number

All wired units must be numbered when the system is used for first time or when adding or replacing wired conference units.



■ **WiredMic(s)**

- Enter “WiredMic(s)”, the LED indicators on the wired units connected will blink;



- Press the keys on the wired units one by one to number each unit, the button indicating light will be deactivated;
- Once all units are numbered, reboot the CMU to update the number information.

■ **Interpreter Units (only for HCS-4385U)**

- Enter “Interp’”, all the interpreter units enter numbering status, and the ‘B’ indicator light was turned on, the LCD of the main unit is shown as following:



- Turn the primary knob to select a number (1-6), and press the ‘B’ button to confirm;
- Press the knob to stop numbering and return to upper level menu.

2.5.23 Mic. IR Strength

When more speakers give speech at the same time, the audio signals the main unit received may be intermittent because of the different distances between the microphones and the receiver may lead to interference between channels. Now enable “Mic. IR Automatic adjusting”, the interference can be reduced obviously.



- Rotate the operation knob to select “Yes” or “No”;
- Press the knob to save.

2.5.24 Mic. Led Setting

Set up the color of indicator lamp rings when turn on the microphone and the “ON/OFF” button.



- Rotate the operation knob to select “Green For Mic. On” or “Red For Mic. On”;

Option	State	Mic.	Button
Green For Mic. On	Speaking	Green	Green
	Apply	Red	Red
	Voice (no speaking)	Off	Red
Red For Mic. On	Speaking	Red	Red
	Apply	Green	Green
	Voice (no speaking)	Off	Green

b) Press the knob to save.

2.5.25 USB Audio Setting

Enable/disable USB audio function. The USB audio will engage one S.I. channel.

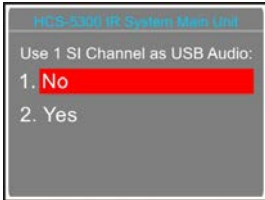

- Rotate the operation knob to select “Yes” or “No”;
- Press the knob to save;
- Reboot the main unit to enable.

2.5.26 License

Install the Web Server process and see the licenses list of the main unit.



■ When selecting “Install”:



- Insert the U-disk and the Web Server process will be installed automatically. “Success” will be displayed on the LCD if the installation successful.
- Reboot the main unit to enable Web Server.

■ When selecting “List”:

 see the licenses list.

2.5.27 Dante Audio Mode

Set the output mode of Dante.

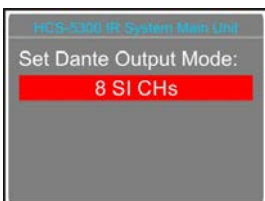

- Rotate the operation knob to select the output mode;
 - **8 SI CHs:** Dante output the signals of 0 to 7 SI

channels;

- **LINE OUT + 6 SI CHs:** Dante output the signals of LINE OUT1+LINE OUT2+0 to 5 SI channels;
- Press the knob to save and return to the upper level menu.

2.5.28 RS-232 Baudrate

Set the baudrate of RS-232.

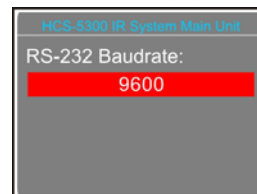

- Rotate the operation knob to select “9600” or “115200”;
- Press the knob to save and return.

2.5.29 Noise Elimination

Enable the noise elimination function for current microphone or not.

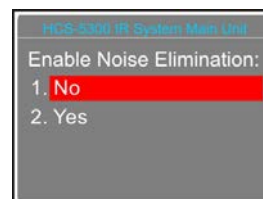

- Rotate the operation knob to select “No” or “Yes”;
- Press the knob to confirm the operation and return to the upper level menu.

2.5.30 Line Out1 Noise Gate

Enable/Disable the line out1 noise gate.

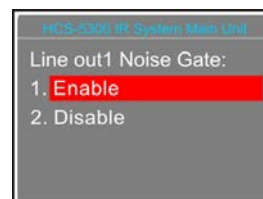

- Rotate the operation knob to select “Enable” or “Disable”;
- Press the knob to save and return to the upper level menu.

2.5.31 Retractable Mic.

Control (retract/raise) the array microphone of HCS-4851/50 series.



- a). Rotate the operation knob to select “Control” or “Sync Number”;
 - If select “**Control**”, use the “MENU” button to go to step b);
 - If select “**Sync Number**”, use the “MENU” button to go to step c);



- b). Rotate the operation knob to select “Retract” or “Raise”;

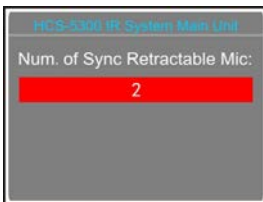

- c). Rotate the operation knob to set sync number from 1 to 4;
- d). Press the knob to confirm the operation and return to the upper level menu.

2.5.32 Interp. Outgoing

Enable/disable to switch the output channel when the microphone of HCS-8385 interpreter unit is available.

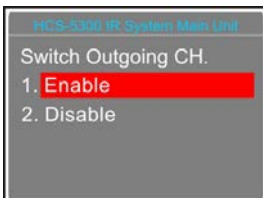

- c). Rotate the operation knob to select “Enable” or “Disable”;
- d). Press the knob to confirm the operation and return to the upper level menu.

2.5.33 Interp. Units LED

Enable/disable to switch the interpretation units green LED.

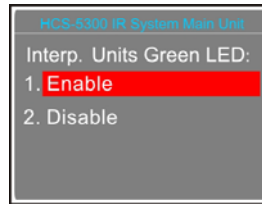

- a). Rotate the operation knob to select “Enable” or “Disable”;
- b). Press the knob to confirm the operation and return to the upper level menu.

2.5.34 Voice of God Setting

Output interpreter voice to the 07 S.I. channel or not when interpreter speaks by pressing button “C”.

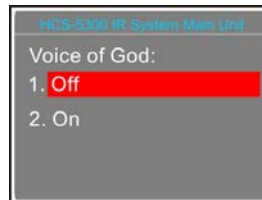

- a). Rotate the operation knob to select “On” or “Off”. Settings for “On”: No output for channel C;
- b). Press the knob to confirm the operation and return to the upper level menu.

Note:

- ☞ The USB input and the wired unit with the 04 carrier will be mute.

2.5.35 One Touch Turn On

Enable/disable to turn on the microphone at the same time when power on the HCS-5380C/D conference unit.



- a). Rotate the operation knob to select “Enable” or “Disable”;
- b). Press the knob to confirm the operation and return to the upper level menu;
- c). Reboot the unit to enable the setting.

2.5.36 Floor From MI SI

Receiver floor from HCS-8300MI S.I. or not when connecting to HCS-8300MI.

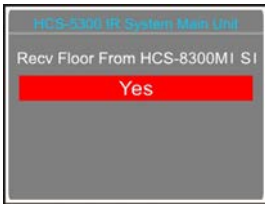

- Rotate the operation knob to select “Yes” or “No”;
- Press the knob to save and return to the upper level menu.

2.5.37 Screensaver

Set the screensaver, if no operation in 3 minutes will enter the screensaver state when enable.

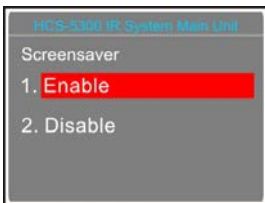

- Rotate the operation knob to select “Enable” or “Disable”;
- Press the knob to save and return to the upper level menu.

2.5.38 Dante Boost

Adjust Dante Boost, range: 0 dB - +20 dB.

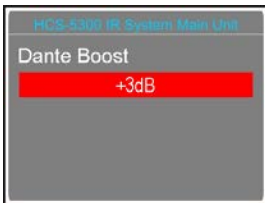

- Rotate the operation knob to adjust Dante boost ;
- Press the knob to save and return to the upper level menu.

2.5.39 About

CMU information includes: firmware version, corporation information and series number, as shown in the following figure – rotate or press the operation knob to return to the upper level menu.

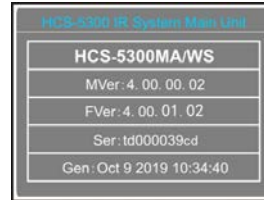

2.5.40 About Dante

Dante information includes: Dante version, device version and device name, as shown in the following figure – rotate or press the operation knob to return to the upper level menu.



2.5.41 Power Management

Press and hold the Standby button to enter power management interface, as shown as the following figure:

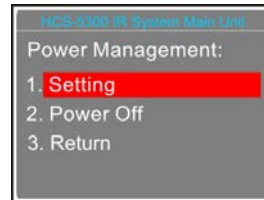

- Rotate the operation knob to select “Setting”, “Power Off” or “Return”;
 - If “**Power Off**” is selected, the main unit switches to standby mode;
 - If “**Return**” is selected, the main unit return to the initial interface;
 - If “**Setting**” is selected, then select enable the standby key or not;

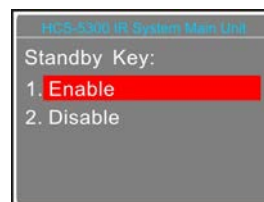

- Rotate the operation knob to select “Disable” or “Enable”;
 - If “**Enable**” is selected, power on through the “POWER” switch and the standby key;
 - If “**Disable**” is selected, power on directly through the “POWER” switch;

c). Press the operation knob to save and return to the upper level menu.

Note:

☞ When power down the main unit, please press and hold the standby key to enter power management interface, then select “**Power Off**” and press the operation knob to confirm. Please do not use the switch button on the back of the main unit to shutdown directly; otherwise, it may lead to startup error.

2.6 USB Audio

HCS-5300M/A has a built-in USB Audio (1 channel, 16bit, 32kHz) which can be connected to the computer through USB cable (software requirement: WindowsXP or higher) for digital audio input/output when the “USB Audio Setting” of main unit is enable. We take Win7 system as an example to introduce the function and operation of the USB Audio.

2.6.1 Installation of USB Audio

Once the HCS-5300M/A main unit connects to the computer, the HCS-5300M USB Audio will be detected and activated automatically instead of the default audio device. User can check the information of HCS-5300M USB Audio from “Device Manager- Sound, video and game controllers”, as shown in the following figure:

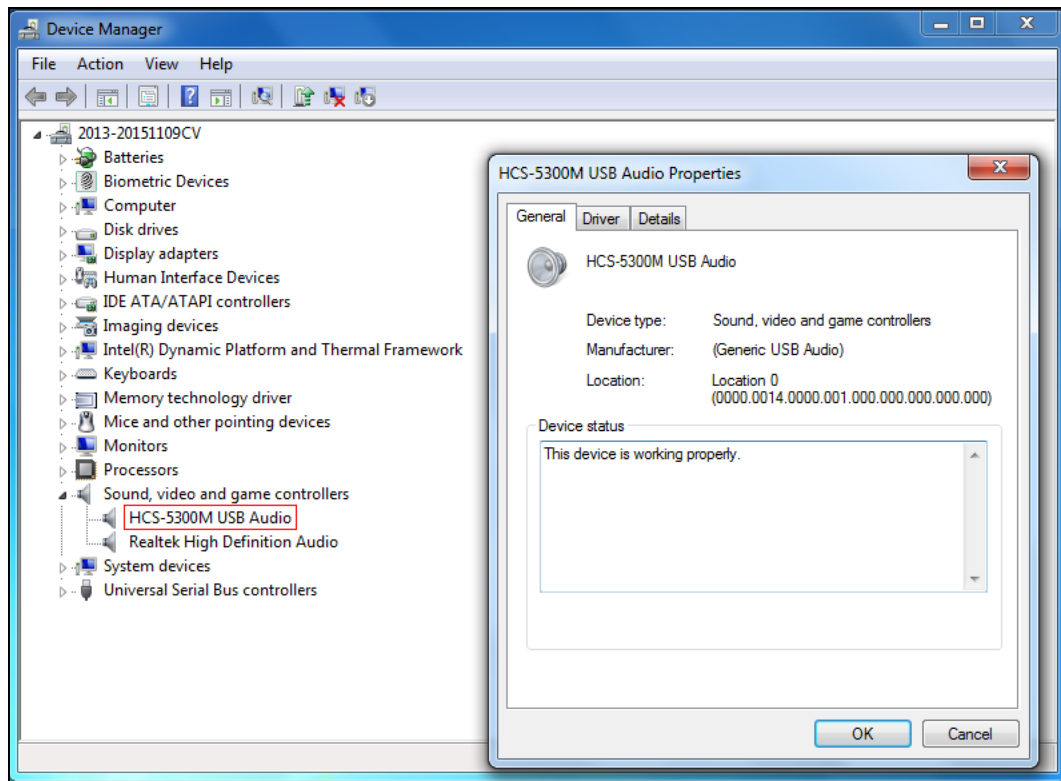

Figurer 2.17: Information of USB sound card

2.6.2 Digital audio input

When the HCS-5300M/A main unit is connected to the computer, the conference units connected in the system are the microphone for digital audio input. Using the recording software or the third party communication software, such as recorder, Skype or QQ and so on, functions like recording, remote instruction, remote communication can be implemented.

Please adjust and test the HCS-5300M USB Audio to a suitable volume when first using. Adjust method: open the control panel-sound (or right click the volume icon on the taskbar and select sound), and select the Microphone (HCS-5300M USB Audio) and modify its setting on the Recording dialog box. Shown as in the following figure:

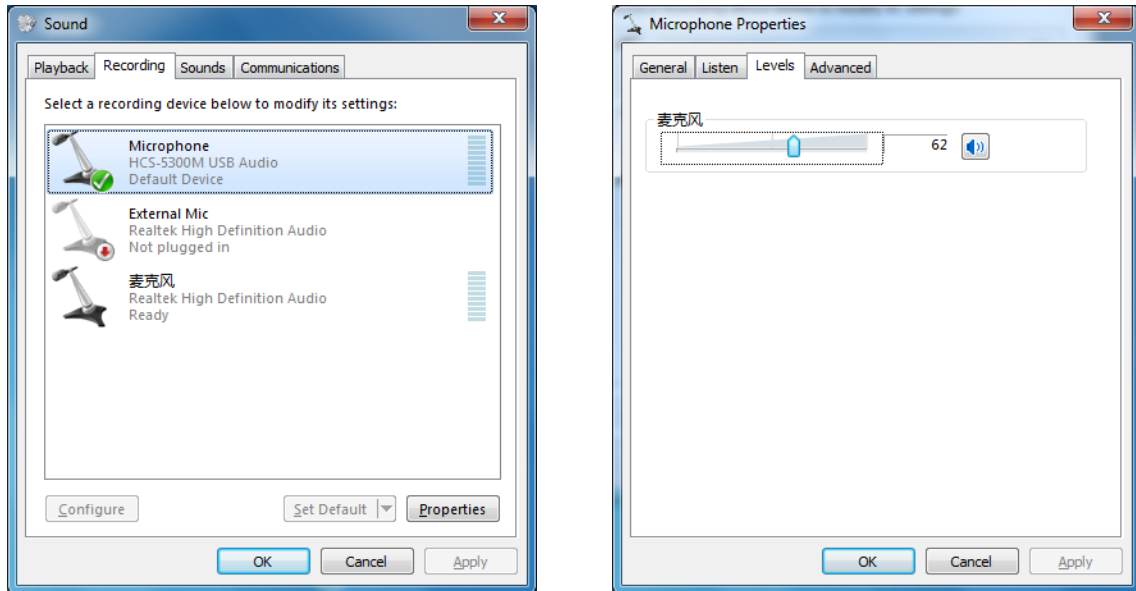

Figure 2.18: Adjusting microphone volume

Note:

- ☞ To avoid feedback, only the output floor audio (except audio of PC) of the main unit will be recorded;
- ☞ Too high volume may lead to distortion, so user can confirm a suitable volume through recording and playback when necessary;
- ☞ When recording under compressed format such as MP3, the audio quality may be affected if unsuitable sampling rate or resolution is selected, so we suggest you to select 32 kHz or its multiple for the sampling rate and 16 bit for the resolution;
- ☞ Please select the HCS-5300M USB Audio as the current device on recording or communication. Usually, HCS-5300M UBS Audio will be activated instead of the default audio device after connecting to the computer. If there is something wrong in recording, may be the audio device selection made a mistake, please select the HCS-5300M USB Audio manually

2.6.3 Digital audio output

The HCS-5300M/A main unit can be connected to the computer for digital audio output. Please adjust and test the HCS-5300M UBS Audio to a suitable volume when first using. Adjust method: open the control panel-sound (or right click the volume icon on the taskbar and select sound), and select the speakers (HCS-5300M UBS Audio) and modify its setting in the Playback dialog box, as shown in the following figure:

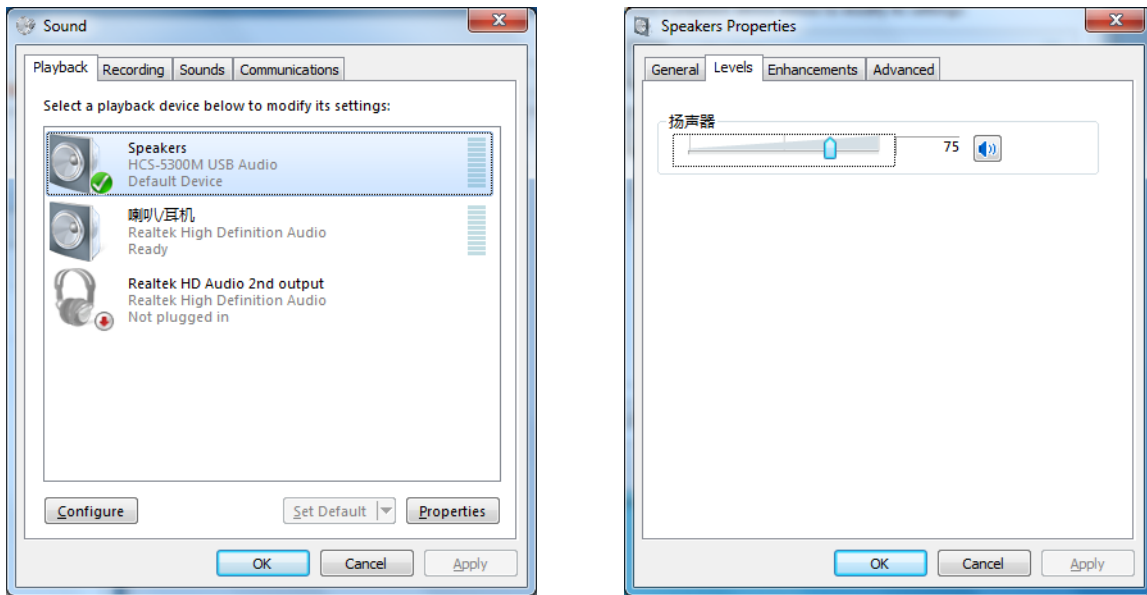

Figure 2.19: Adjusting playback volume

Note:

Please select the HCS-5300M USB Audio as the current device on playback. Usually, HCS-5300M UBS Audio will be activated instead of the default audio device after connecting to the computer. If there is something wrong about playback, may be the audio devices selection made a mistake, please select the HCS-5300M USB Audio manually. Take the Media Player as an example to show the sound card selection:

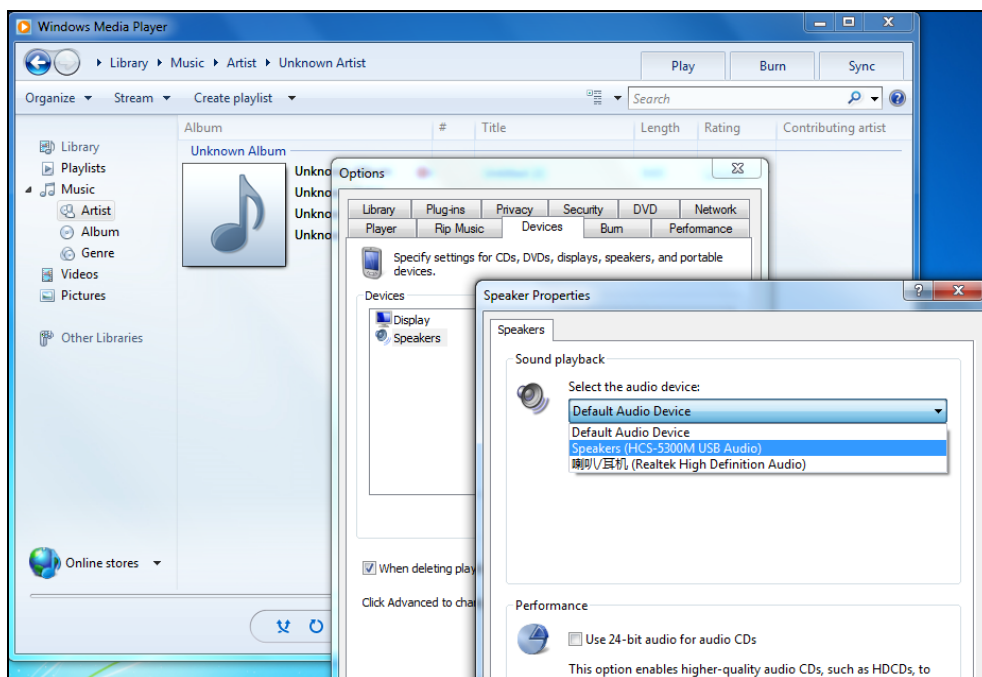

Figure 2.20: Audio device selection

Chapter 3 Digital infrared transceiver

3.1 Overview

The digital infrared transceiver manages the communication between the main unit and the conference units. It can be mounted onto the ceiling or the wall for optional coverage or fixed onto a tripod at any appropriate spot.

Types:

HCS-5300TD/80

Digital Infrared Transceiver (ceiling, wall or tripod-mounted, suitable for less than 6 m height)

HCS-5300TDS/80

Digital Infrared Transceiver (suspension)

HCS-5300TH/80

Digital Infrared Transceiver (ceiling, wall or tripod-mounted, powered from HCS-5300M or power adapter, suitable for higher than 6 m)

HCS-5300TWN/80

Digital Infrared Transceiver (ceiling, wall or tripod-mounted)

3.2 Functions and indications

3.2.1 Digital infrared transceiver

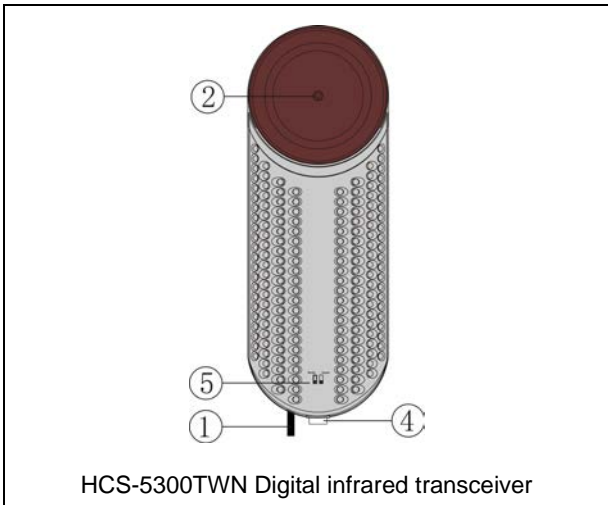
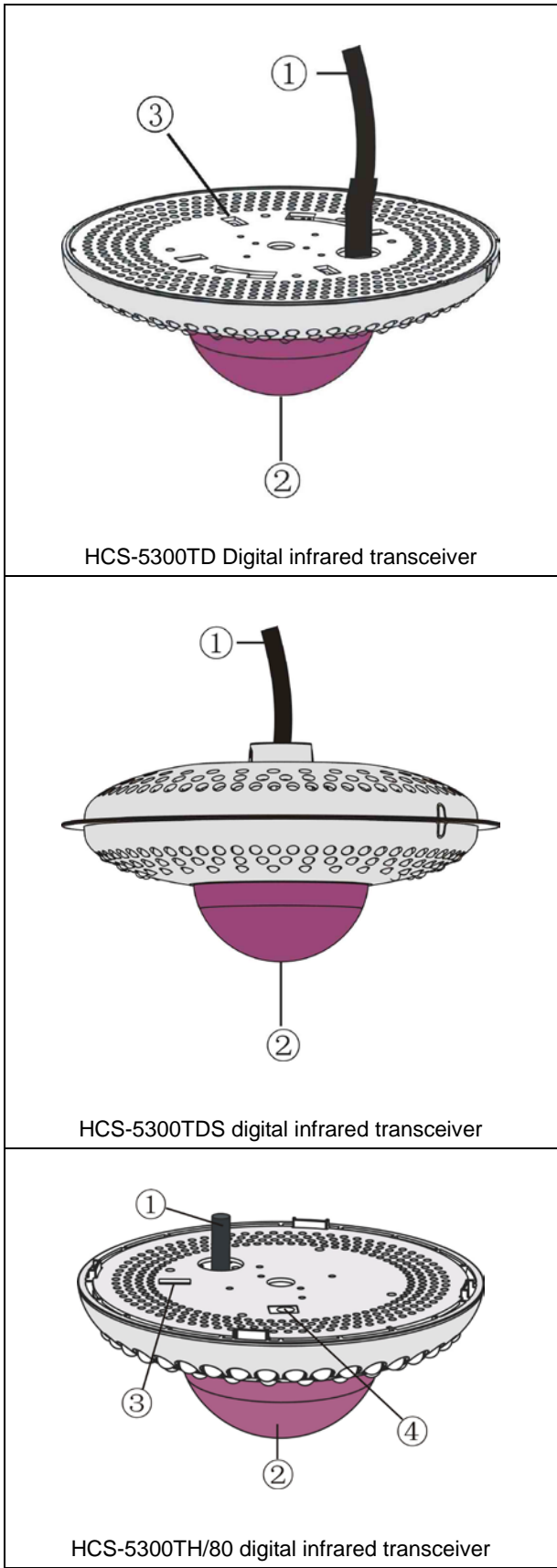

Figure 3.1 HCS-5300T digital infrared transceiver

Figure 3.1:

1. 2-meter 6 PIN cable CBL-5300
2. Power indicating light
3. Switchers for radiation area selection

Note:

The HCS-5300TDS/80 digital infrared transceiver has four built-in switchers and the HCS-5300TH/80 has one built-in switcher to select the radiation area, they were switched to “ON” in the factory. If necessary in the practical application, please remove the top cover and switch off one or more radiated areas by selecting the corresponding switcher(s).

4. Power adapter port

- for connecting to HCS-ADP24V adapter (HCS-5300TH)
- for connecting to HCS-ADP24V2 adapter (HCS-5300TWN)

5. Dip switches, for adjust the intensity of the infrared emitters on the width and depth.

3.2.2 Digital infrared cable splitter

HCS-5352 digital infrared cable splitter with one input and four outputs that can be used to connect four transceivers/ receivers at most.

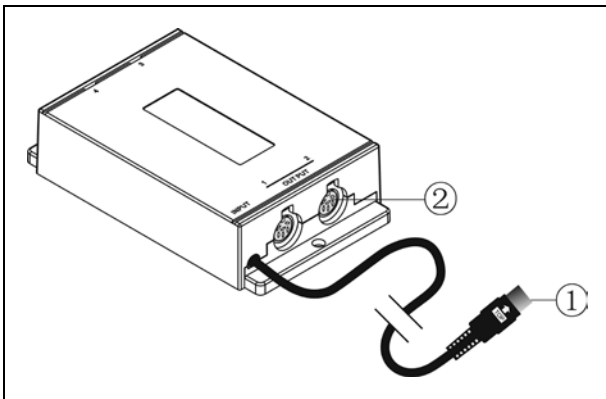
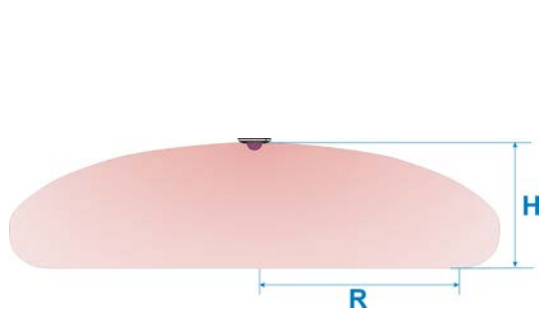

Figure 3.2 HCS-5352 cable splitter

Figure 3.2:

- 1. To the transceiver interface of the main unit**
- 2. Four transceiver/ receiver interfaces**

3.3 Infrared service area



a.HCS-5300TD(S)/80

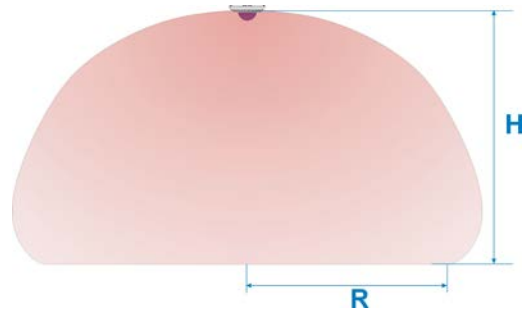

b.HCS-5300TH/80

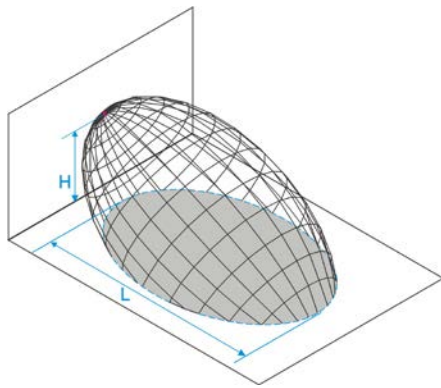

c.HCS-5300TH/80

Type No.	Mounting height (H)	Coverage area radius (R)
HCS-5300TD/80	2.5 ~ 3.0 m	13 m
HCS-5300TDS/80	3.5 ~ 4.5 m	11 m
	5.0 ~ 7.0 m	9 m
HCS-5300TH/80	6.0 m	9 m
	9.0 m	11 m
	12 m	9 m
Type No.	Mounting height (H)	Coverage area Length (L)
HCS-5300TWN/80	under 5 m	15 m

* The table above is the coverage area of a single transceiver; but the actual coverage area will be affected by the number of the transceivers and the length of the cable connected in the system.

Figure 3.3 Service area of HCS-5300/80 digital infrared transceivers and receiver

3.4 Position planning

3.4.1 Precautions in planning the digital infrared transceiver/receiver

Due to strict demands on intensity and stability of infrared signals in an infrared wireless conference system, please read section 1.4 carefully and take all aspects of infrared signal transmission into consideration before planning the mounting position.

3.4.1.1 Avoid direct sunshine

Exposing the transceiver/receiver to sunshine or an infrared illuminant may cause system failure or noise. To guarantee adequate intensity and stability of infrared signals avoid mounting the transceiver/receiver near to an infrared illuminant, as shown in the following figure:

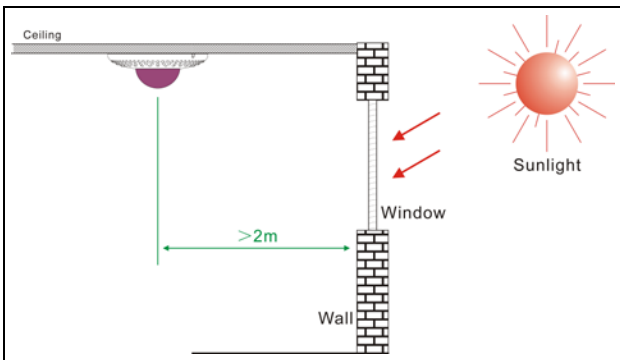

Figure 3.4 Digital infrared transceiver/receiver position (near window)

- Cover the window with a curtain to protect the transceiver/receiver from direct solar radiation;
- The distance between the transceiver/receiver and the window nearby must be more than 2 meters.

3.4.1.2 Stay away from lighting equipment

Although HCS-5300 system has good anti-interference performance to ambient light, the distance of the transceiver/receiver from lighting equipment must be at least 50 cm to guarantee adequate intensity and stability of infrared signals.

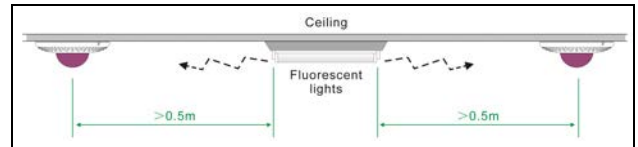

Figure 3.5 Digital infrared transceiver/receiver position (near lighting equipment)

Note:

- ☞ If the position of lighting equipment is higher than the position of the transceiver/receiver, its disturbance can be ignored.

3.4.1.3 Stay away from wall, pillar and other obstacle

Because objects in a meeting room may cause infrared light reflection (see section 1.4.2), the transceiver/receiver should not be mounted near to a wall, pillar or other obstacle; otherwise, the transceiver/receiver could feature malfunctions by detecting the reflected own infrared signals.

The distance of the transceiver/receiver to the obstacle should be at least 30 cm.

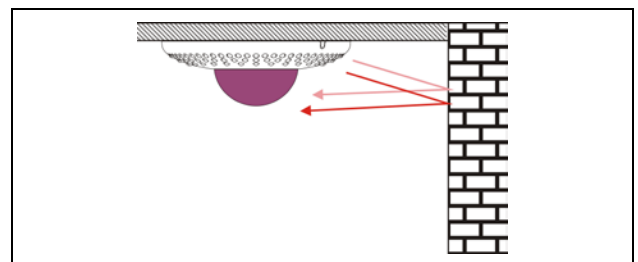

Figure 3.6 Reflected infrared light received by the transceiver/receiver

Note:

- ☞ A distance of 30 cm will be adequate to make the transceiver/receiver unaffected. However, if highly reflective surfaces exist in the meeting room, e.g. mirror, the disturbance still exists.
- ☞ Especially reflections caused by pillars in large halls may cause disturbance.

3.4.1.4 Make each conference unit communicating with more than one transceiver

As shown in the following figure: when the speaker in the front row speaks in an upright position, the infrared signal will be blocked. In conference rooms with conference units in rows, each conference unit should communicate with more than one transceiver to avoid blocking.

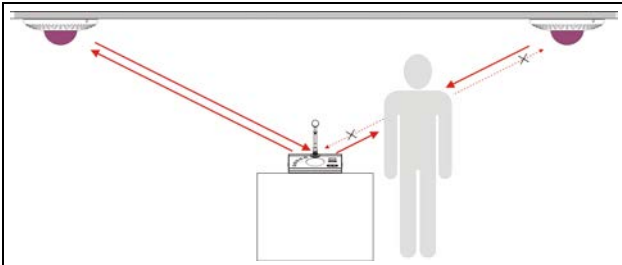

Figure 3.7 Infrared signals blocking

So, each transmitter should communicate with more than one receiver to avoid blocking.

3.4.1.5 Stay away from plasma displays

When planning an infrared wireless discussion system, plasma displays are not appropriate to be used in the venue. If you want to use plasma displays, infrared wireless conference units and infrared wireless transceivers/receivers should not be used closer than 3 meters to the plasma, or the plasma display should be equipped with an infrared filter.

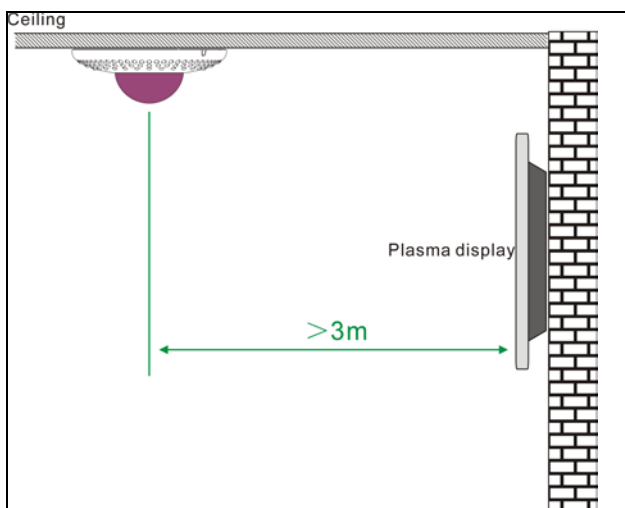

Figure 3.8 Digital infrared transceiver/receiver position (near plasma display)

3.4.2 Planning digital infrared transceiver

The coverage area of the digital infrared transceiver is defined by the distance between the transceiver and the conference unit. Select suitable transceiver type according to the height of the conference room, locate them at reasonable positions and place all conference units within the coverage area.

3.4.2.1 Steps to plan the transceiver

1. Determine the current operating area, e.g. the area where the conference units are used;

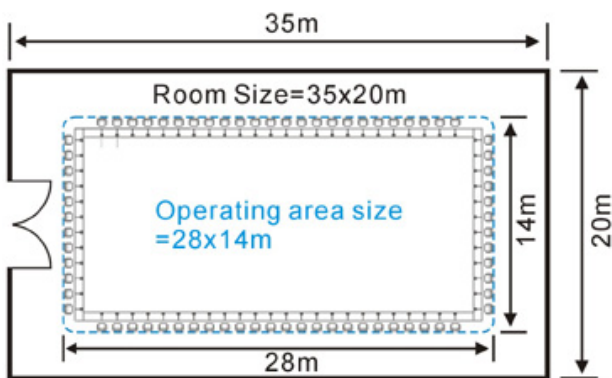

Figure 3.9 Room area and the current operating area

Note:

In most applications, the coverage area of infrared signals is smaller than the area of the whole meeting room. Therefore, first of all, determine the current operating area and the position of the conference units.

2. Select suitable transceiver type according to the height of the conference room and determine the coverage area of a single transceiver (see figure 3.3).
3. Plan adequate transceivers according to the coverage area of a single transceiver and make sure that they can cover the system operating area;

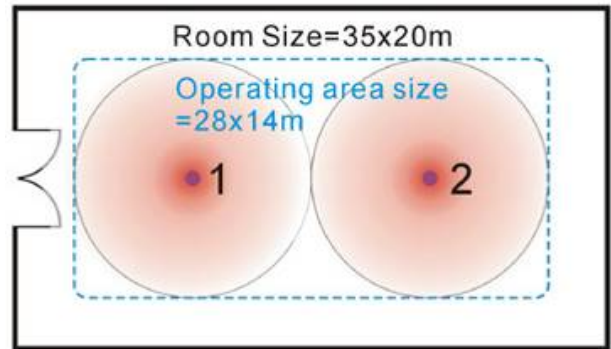

Figure 3.10 Two transceivers cannot cover the whole operating area

Apparently, only two transceivers cannot cover the system operating area completely.

Therefore, we select four transceivers and position them evenly in the meeting room. The overlap effect on the border of every transceiver will cover all blind areas (see section 1.4.5).

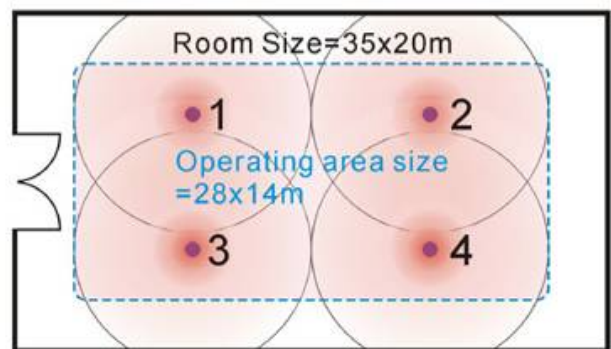

Figure 3.11 Four transceivers cover the whole operating area

Note:

The distances between the main unit and every transceiver must be equivalent to avoid multipath effect.

4. Determine the position of the main unit and distributors (if used). Plan the paths between the transceivers and the main unit according to section 3.4.3. Proceed to cable connection.

3.4.2.2 Example for planning the transceiver

【Square table arrangement】

If the transceivers are arranged as shown in the following figure, the coverage area of infrared signals will cover the entire meeting room.

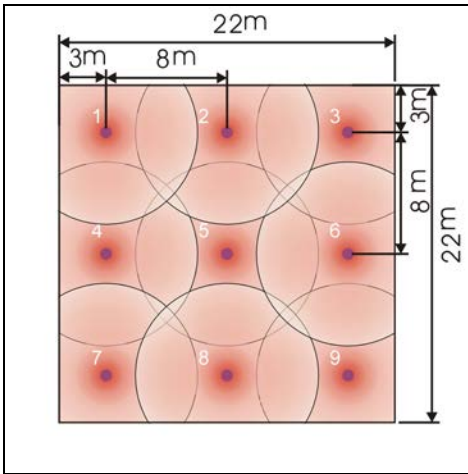

Figure 3.12 Planning the transceiver (square conference room)

【Round table arrangement】

Apparently, only one transceiver will cover all conference units if these are within the circular coverage area of one single transceiver,

However, to avoid blocking communication, two or more transceivers are indicated.

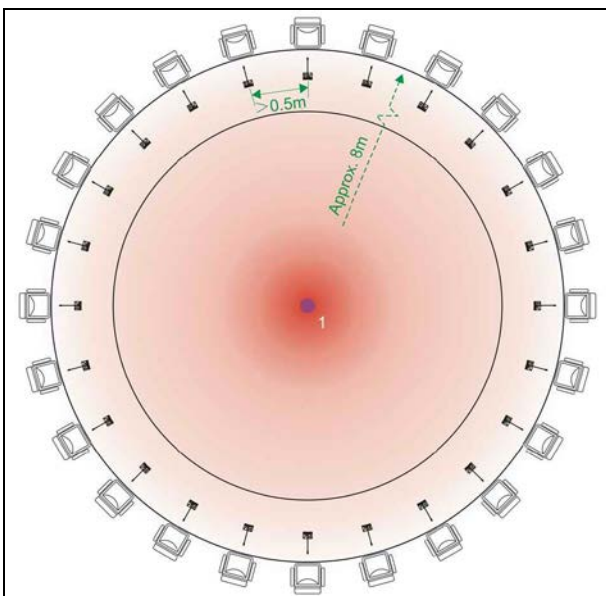

Figure 3.13 Planning the transceiver (round table arrangement)

【Rectangular table arrangement】

Generally: In conference rooms with identical dimensions, the position of the transceivers is determined by the arrangement of the conference units (Figure 2.14 to 2.17)

The following figures show the ideal position planning of the transceivers for a

- A) conference style arrangement (circulatory seating)
- B) parliamentary arrangement

A) Conference style seating (circulatory seating)

Within the circulatory seating operating area of the conference units, the transceivers must be placed evenly. Make sure that all conference units communicate with at least two transceivers.

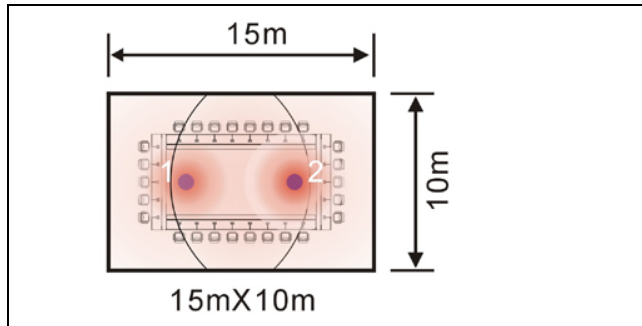

Figure 3.14 Arrangement according to the seating style (conference style seating)

The following figure shows the position planning for conference style seating if the conference rooms have distinct areas.

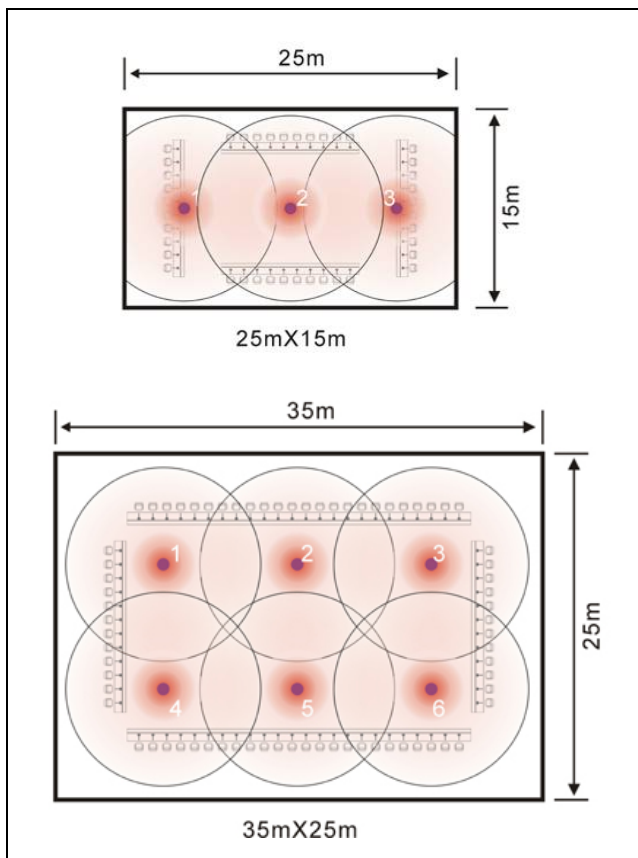

Figure 3.15 Planning the transceiver (conference style seating)

B) Parliamentary seating

If the transceivers for parliamentary seating would be placed evenly as shown in Figure 3.14, transceiver No. 1 could only communicate with the few conference units in the last row (left row in Figure 3.16), compared to the transceiver placed over the front row. The reason is that the infrared receiving glass is at the frontage of the conference unit and is orientated to the podium. Therefore the transceivers are now placed according to Figure 3.16. Transceiver No. 1 was moved to the right compared to Figure 3.14. The transceiver in the front row can effectively enlarge the coverage area.

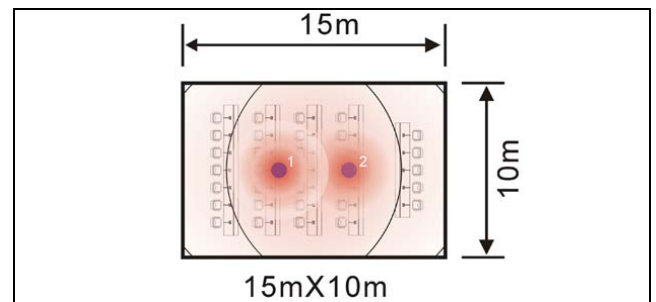

Figure 3.16 Arrangement according to the seating style (parliamentary seating)

The following figure shows the position planning for parliamentary style seating if the conference rooms have distinct areas.

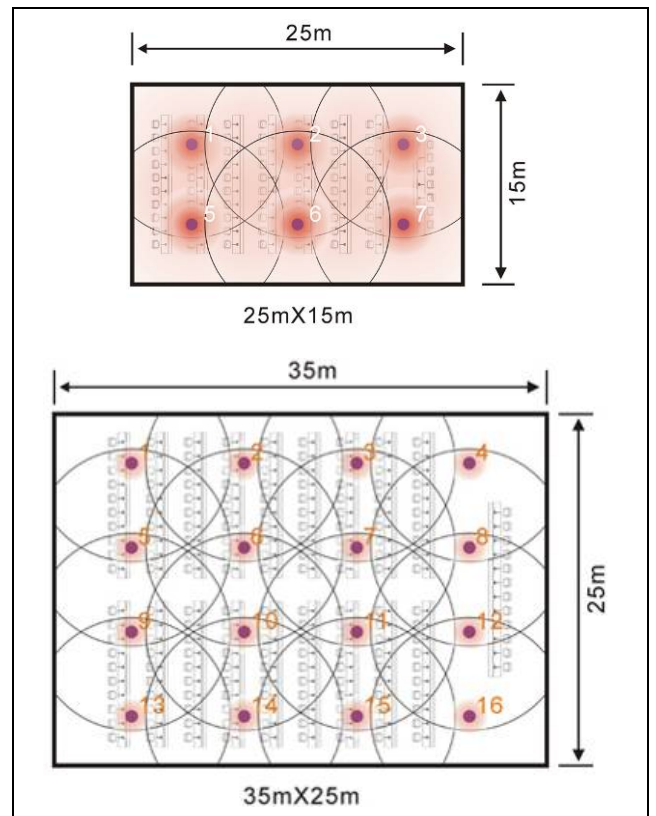

Figure 3.17 Planning the transceiver (parliamentary seating)

【Balcony venue】

In a balcony venue, with a higher ceiling and the shielding from the gallery, the transceiver planning must depend on the height of the ceiling and the style of seating. For example, HCS-5300TH/80 can be used to communicate with the units on the chairman platform and the ground floor for the area not shaded by the balcony.

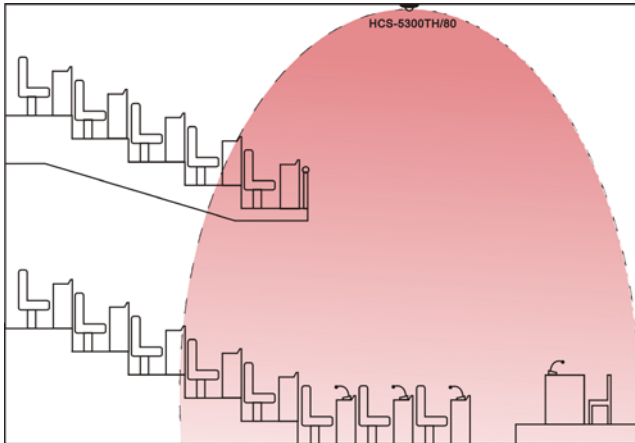

Figure 3.18 Planning the transceiver (balcony venue)

3.4.3 Planning the path from main unit to transceiver

3.4.3.1 Cautions for cable connecting

■ The distances between main unit and every transceiver must be equal

If the footprints of two transceivers overlap, the conference unit can receive infrared signals from more than one transceiver. As described in section [1.4.5](#), overlap effect or multipath effect will occur: the intensity of the receiving signals is enhanced if the two signals have the same phase; but the intensity of the receiving signals will weaken if the two signals have the reverse phase. To avoid multipath effect, the distance between the main unit and all transceivers must be equal. As shown in the following figure, all cables for "A" must be identical in length when the transceivers are installed in the same space.

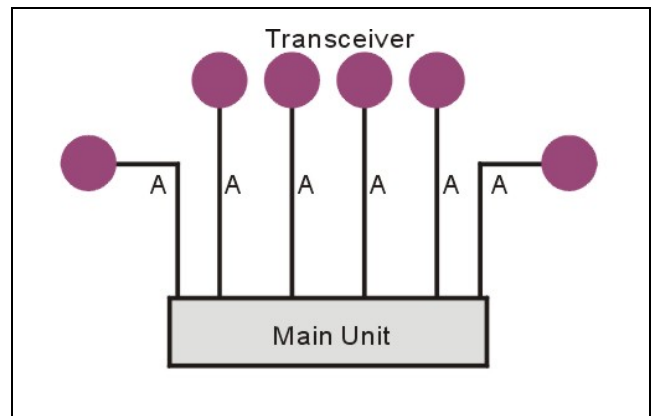

Figure 3.19 Without distributors, all the cable lengths must be equal

■ Cable length between main unit and transceiver should not exceed 60 m

Cable length A should not exceed 60 meters in the previous figure.

■ Avoid parallel cabling of high voltage (power) cables and the cables between the infrared transceivers and the main unit

Communication between infrared transceivers and the main unit may be interfered by high voltage. To reduce the risk of interference, avoid parallel cabling with high voltage cables (includes mains voltage). If this cannot be avoided, please shield the cable with iron pipe.

3.4.3.2 Using distributor

If using distributors, do not use more than one distributor in one branch, or it will increase high frequency signal loss and may cause system fault.

Connections to transceivers with and without distributors in the branch, cannot work together in one system. When installed in several rooms, the cable splitter must be connected to the main unit directly and the cable lengths to different rooms do not need to be equal, as shown in figure 3.20.

- All cable lengths B1 must be equal;
- All cable lengths B2 must be equal;
- B1 and B2 are used for different rooms, and do not need to be equal;

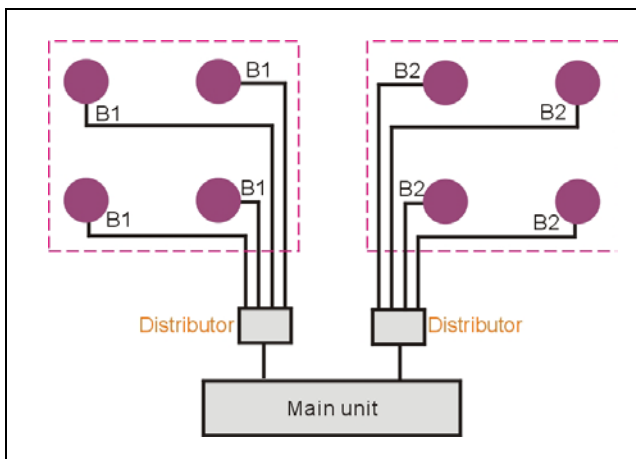

Figure 3.20 Plan the path from main unit to transceiver with distributor for several rooms

Note:

- ☞ The same rule is also applicable for two systems installed in one room but have enough distance that they will not interference to each other.

3.5 Installation

3.5.1 Installation of HCS-5300TD/80

3.5.1.1 Ceiling mounted 1

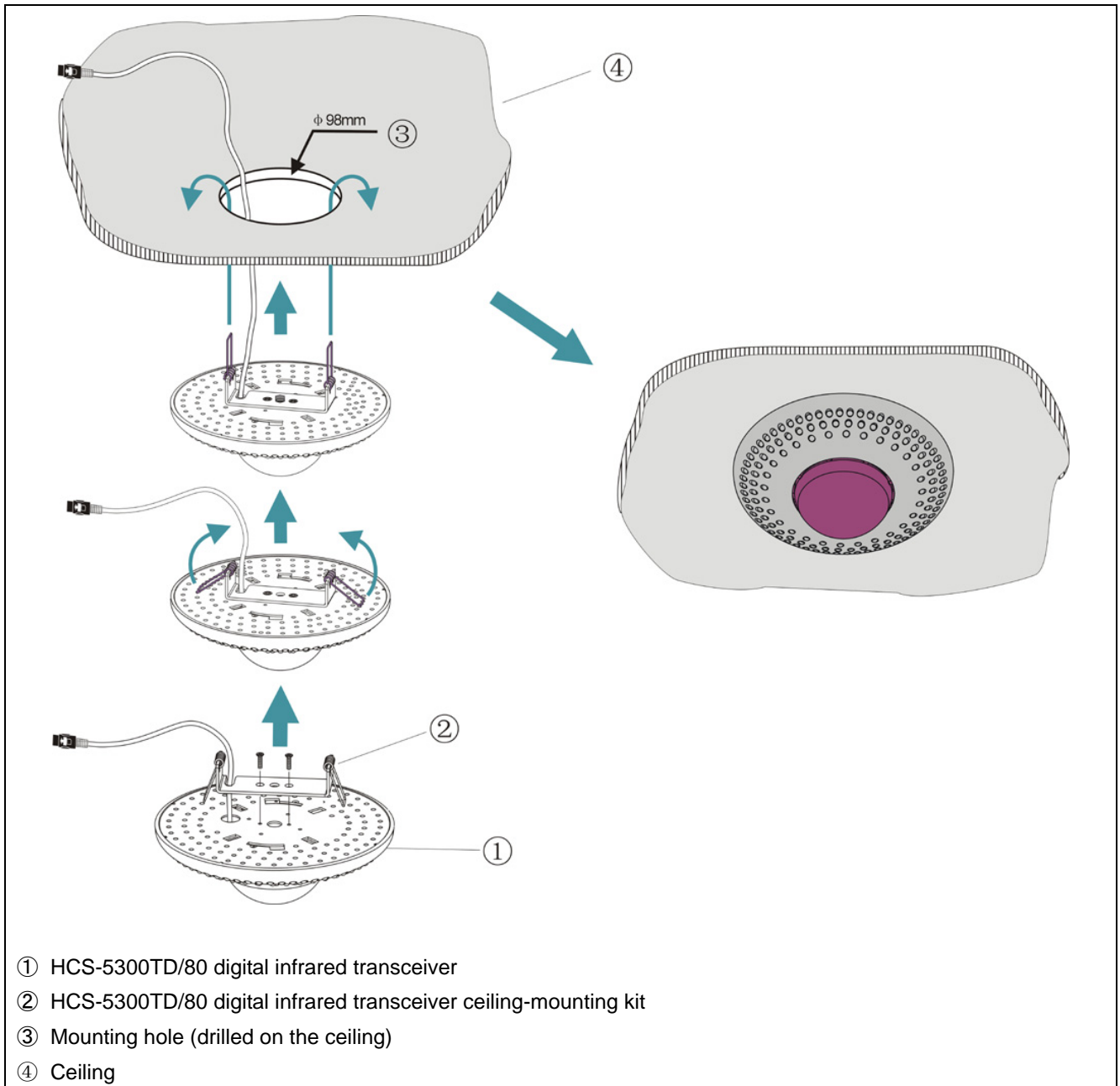

Figure 3.21 HCS-5300TD/80 digital infrared transceiver ceiling mounted

Mounting steps:

Step 1: Install the ceiling mounting kit at the top of the HCS-5300TD/80 Transceiver;

Step 2: Drill a hole with 98 mm diameter into the ceiling (for mounting and heat elimination during operation);

WARNING:

Do not cover the venting to keep good ventilation for the equipment.

Step 3: Insert the cable into the mounting hole;

Step 4: Hold the spring straightly and vertically, insert it into the mounting hole until the base of the HCS-5300TD/80 transceiver can fit with the ceiling.



3.5.1.2 Ceiling mounted 2

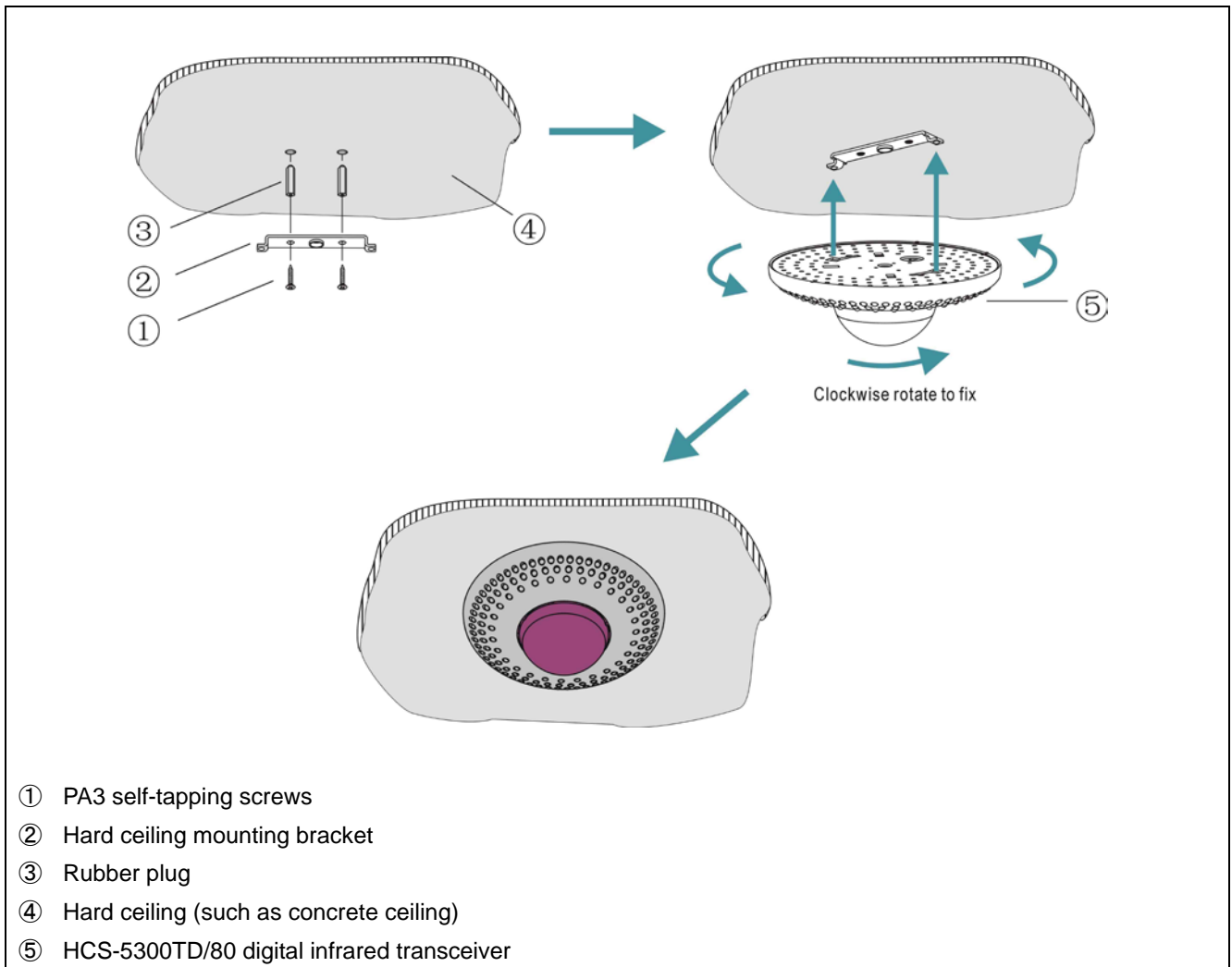

Figure 3.22 HCS-5300TD/80 digital infrared transceiver ceiling mounted

Mounting steps:

Step 1: Position the mounting bracket on the ceiling according to the installation location of the HCS-5300TD/80 and mark the positions of the drilling holes. Drill two holes (5 mm diameter, 30 mm depth) into the ceiling.

Step 2: Put the included rubber plugs into the mounting holes on the ceiling;

Step 3: Fix the mounting bracket on the ceiling with PA3 self-tapping screws;

Step 4: Put the slots of HCS-5300TD/80 digital infrared transceiver into hard ceiling mounting bracket and fix it with clockwise rotation.



WARNING:

☞ This installation method is applicable when the ceiling thickness is greater than the length of the rubber plug.

3.5.1.3 Tripod mounted (Adjustable angle)

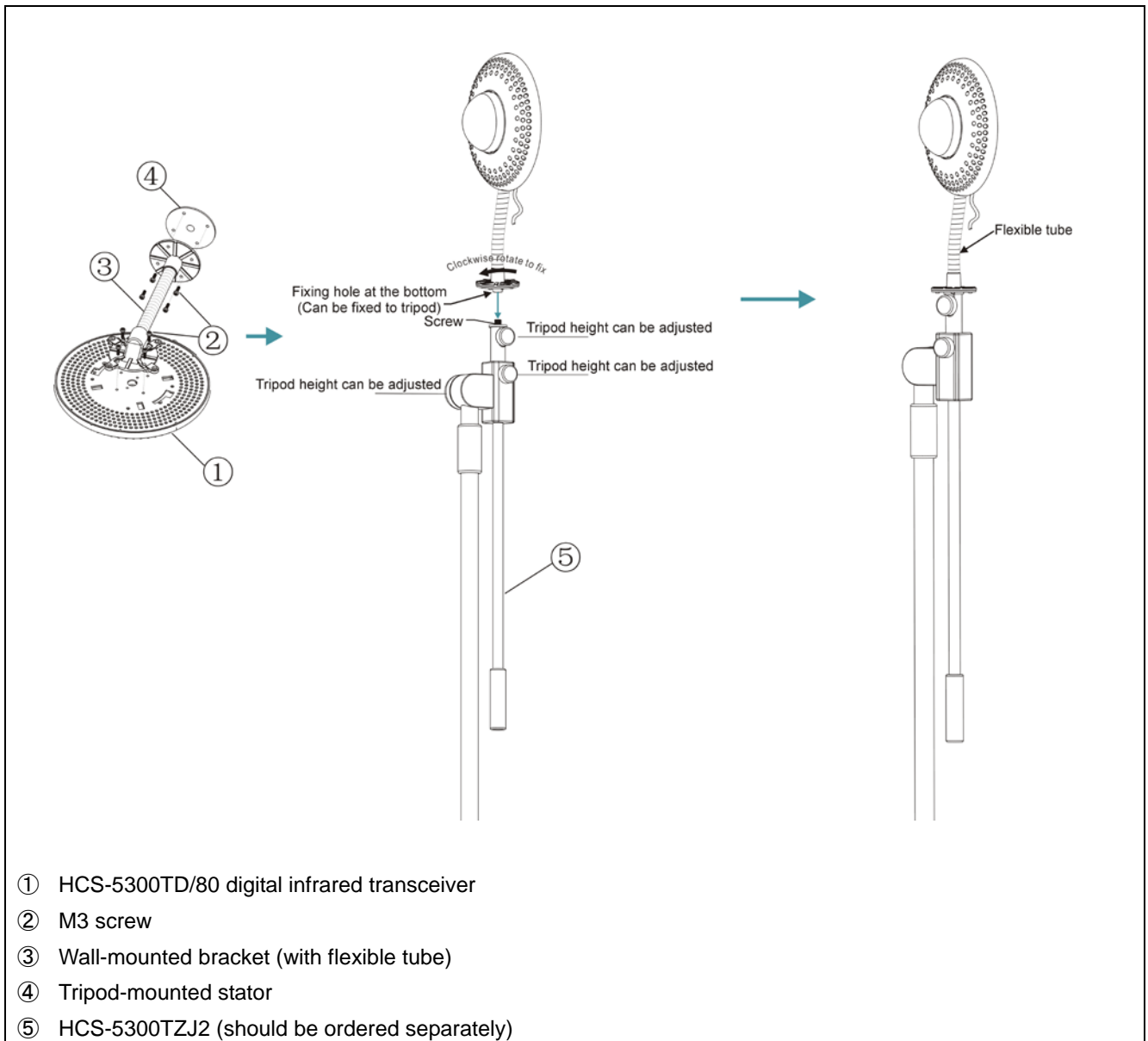

Figure 3.23 HCS-5300TD/80 digital infrared transceiver tripod mounted

Mounting steps:

Step 1: Fix the HCS-5300TD/80 digital infrared transceiver onto the wall-mounted bracket with M3 screws;

Step 2: Fix the tripod-mounted stator onto the other end of the wall-mounted bracket with M3 screws;

Step 3: Aim the mounting hole at the bottom of the tripod-mounted stator to the screw on the tripod;

Step 4: Fix it with clockwise rotation.



3.5.1.4 Tripod mounted

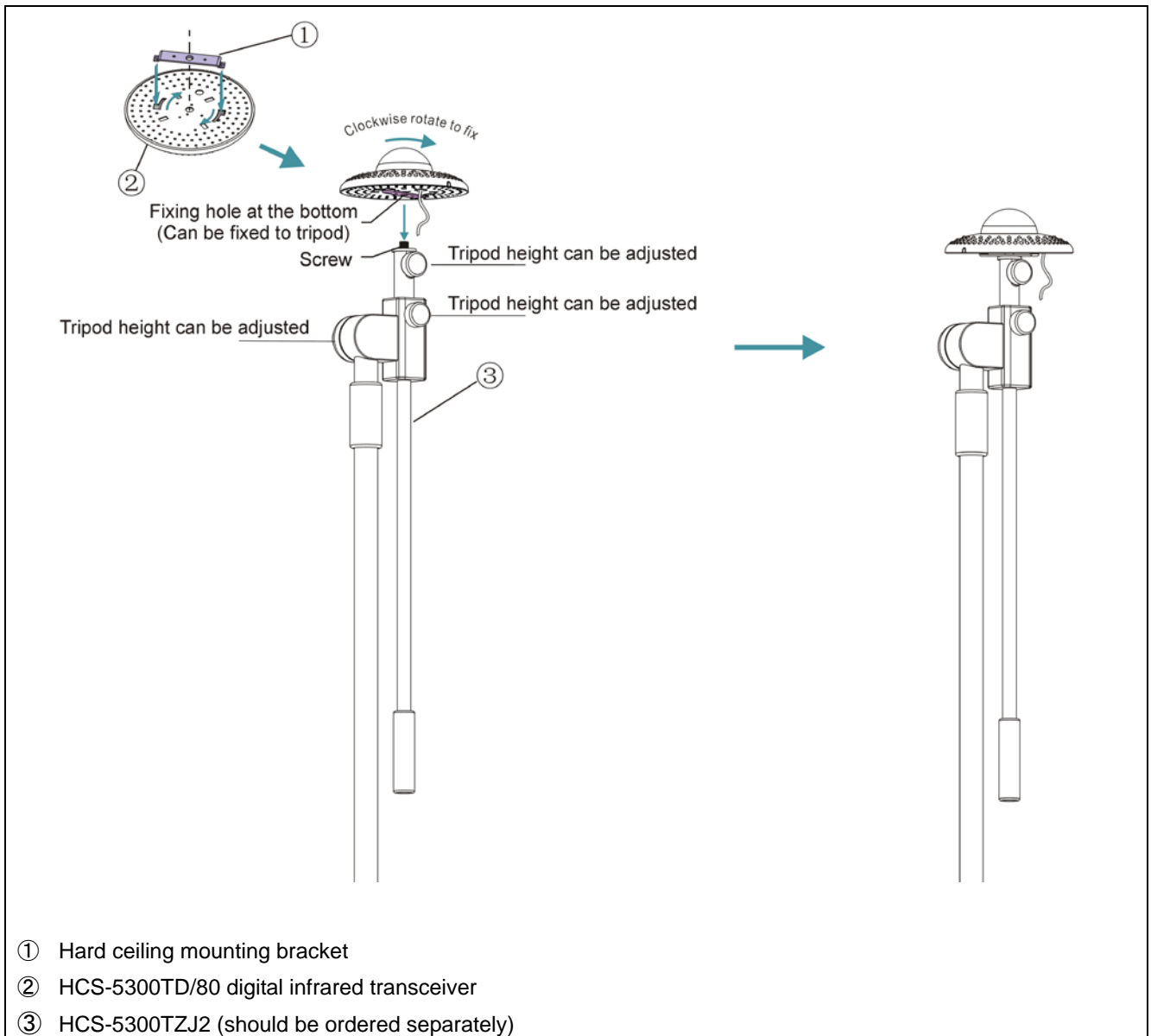

Figure 3.24 HCS-5300TD/80 digital infrared transceiver tripod mounted

Mounting steps:

Step 1: Put the bracket on the bottom of the transceiver and fix it with rotation;

Step 2: Aim the mounting hole at the bottom of HCS-5300TD/80 digital infrared transceiver to the screw on the tripod;

Step 3: Fix it with clockwise rotation.

WARNING:

☞ This installation method is applicable when the ceiling is white and lower than 4 m.

3.5.1.5 Wall mounted (Adjustable angle)

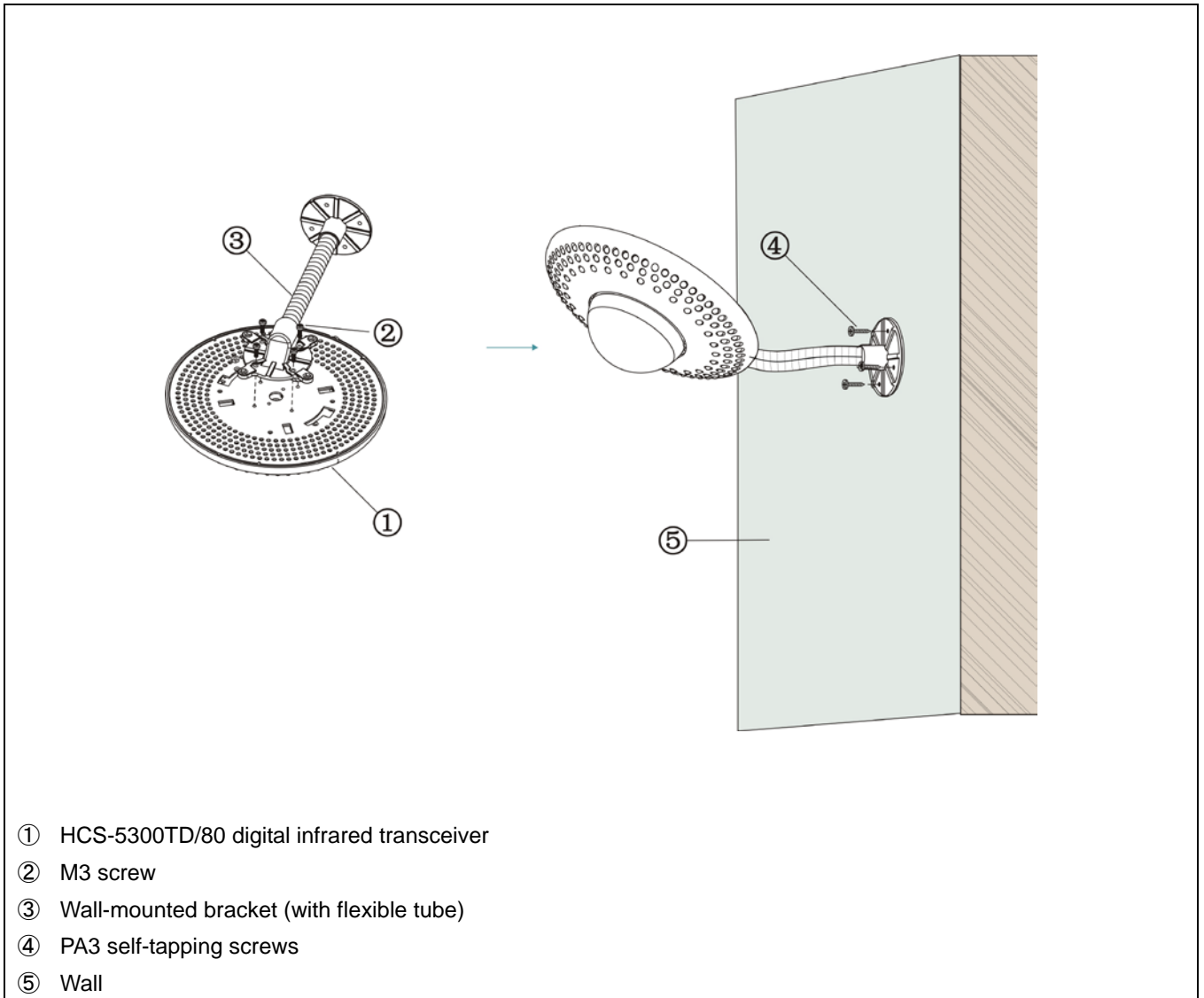

Figure 3.25 HCS-5300TD/80 digital infrared transceiver wall mounted

Mounting steps:

Step 1: Fix the HCS-5300TD/80 digital infrared transceiver onto the wall-mounted bracket with M3 screws;

Step 2: Position the wall-mounted bracket on the wall according to the installation location of the HCS-5300TD/80 and mark the positions of the drilling holes. Drill four holes (5 mm diameter, 30 mm depth) on the wall;

Step 3: Put the included rubber plugs into the mounting holes on the wall;

Step 4: Fix the wall-mounted bracket onto the wall with M3 screws.



WARNING:

☞ This installation method is applicable when the wall thickness is greater than the length of the rubber plug.

3.5.2 Installation of HCS-5300TDS/80

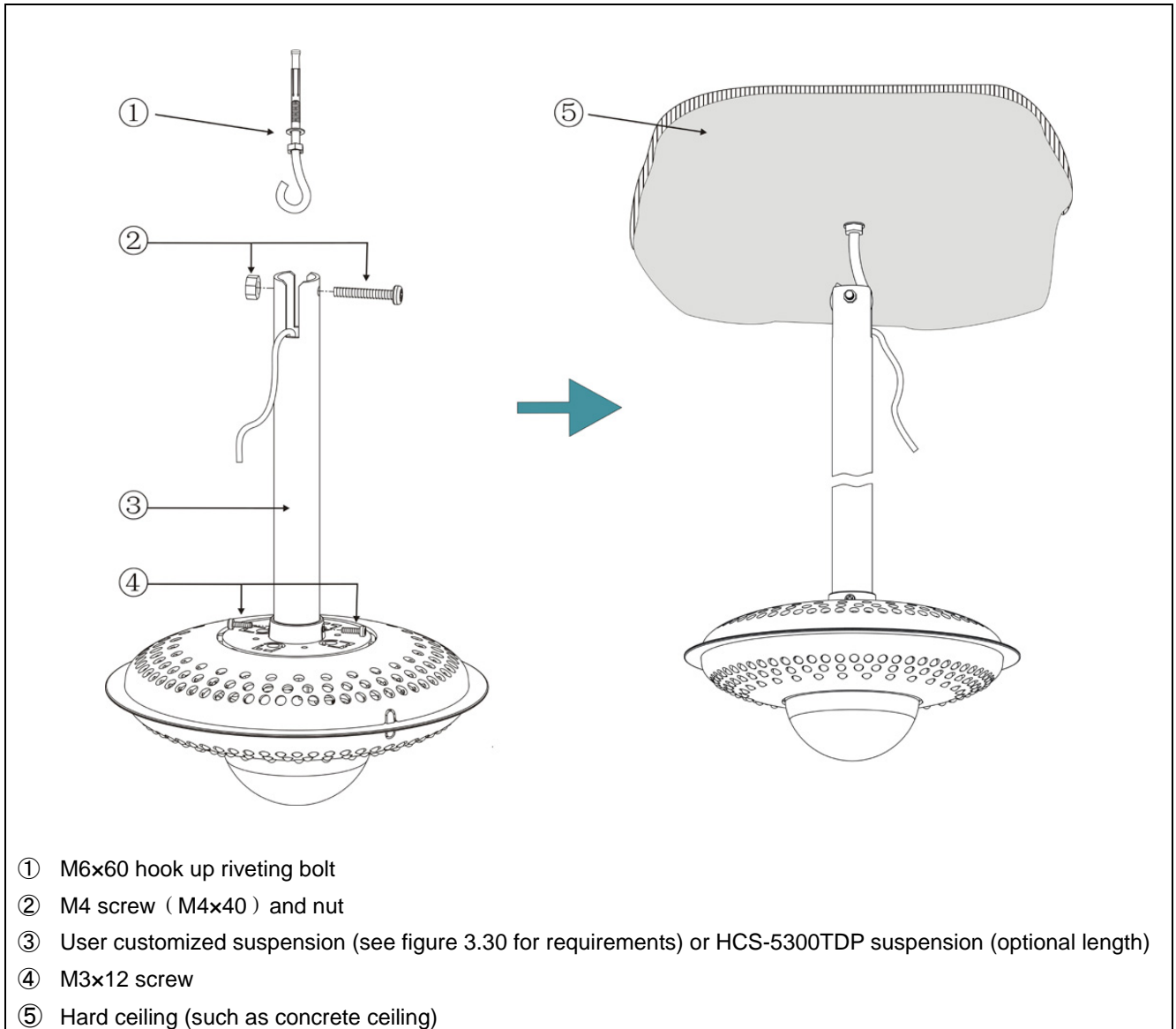

Figure 3.26 HCS-5300TDS/80 digital infrared transceiver suspension mounted

Mounting steps:

Step 1: Fix M6×60 hook up riveting bolt onto the hard ceiling (such as concrete ceiling);

Step 2: Fix HCS-5300TDS/80 digital infrared transceiver onto the suspension with M3×12 screws;

Step 3: Pull the M4 screw over the mounting hole at the top of the suspension and fix it with M4 nut;

Step 4: Hang the suspension on M6 hook up riveting bolt.

WARNING:

☞ This installation method is applicable to hard ceiling (such as concrete ceiling), and when the thickness of the ceiling is greater than the length of M6 screw.



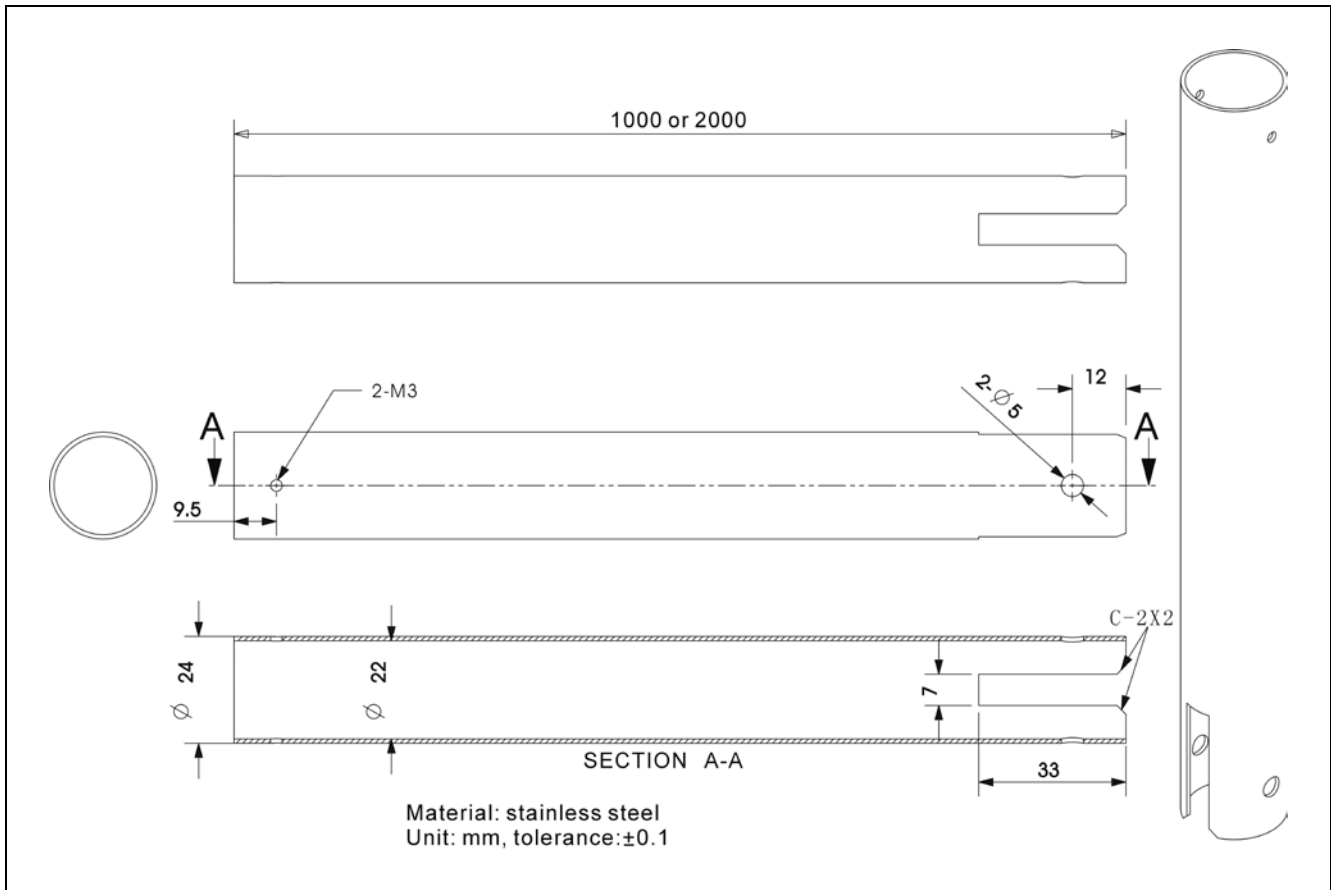

Figure 3.27 Requirements of user customized suspension

3.5.3 Installation of HCS-5300TH/80

3.5.3.1 Ceiling mounted

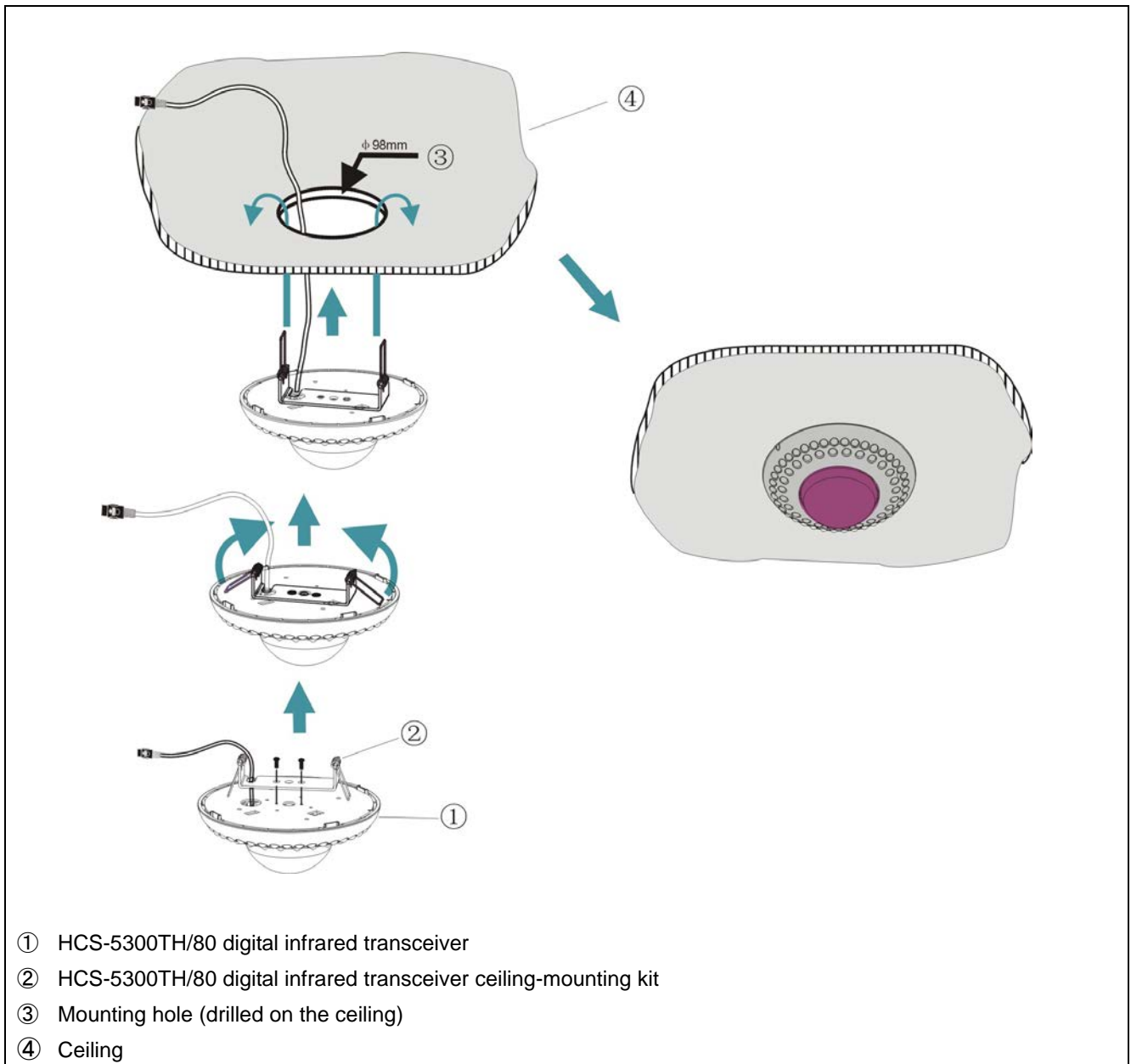

Figure 3.28 HCS-5300TH/80 digital infrared transceiver ceiling mounted

Mounting steps:

Step 1: Install the ceiling mounting kit at the top of the HCS-5300TH/80 Transceiver;

Step 2: Drill a hole with 98 mm diameter into the ceiling (for mounting and heat elimination during operation);

WARNING:

Do not cover the venting to keep good ventilation for the equipment.

Step 3: Insert the cable into the mounting hole;

Step 4: Hold the spring straightly and vertically, insert it into the mounting hole until the base of the HCS-5300TH/80 transceiver can fit with the ceiling.



3.5.3.2 Tripod mounted (Adjustable angle)

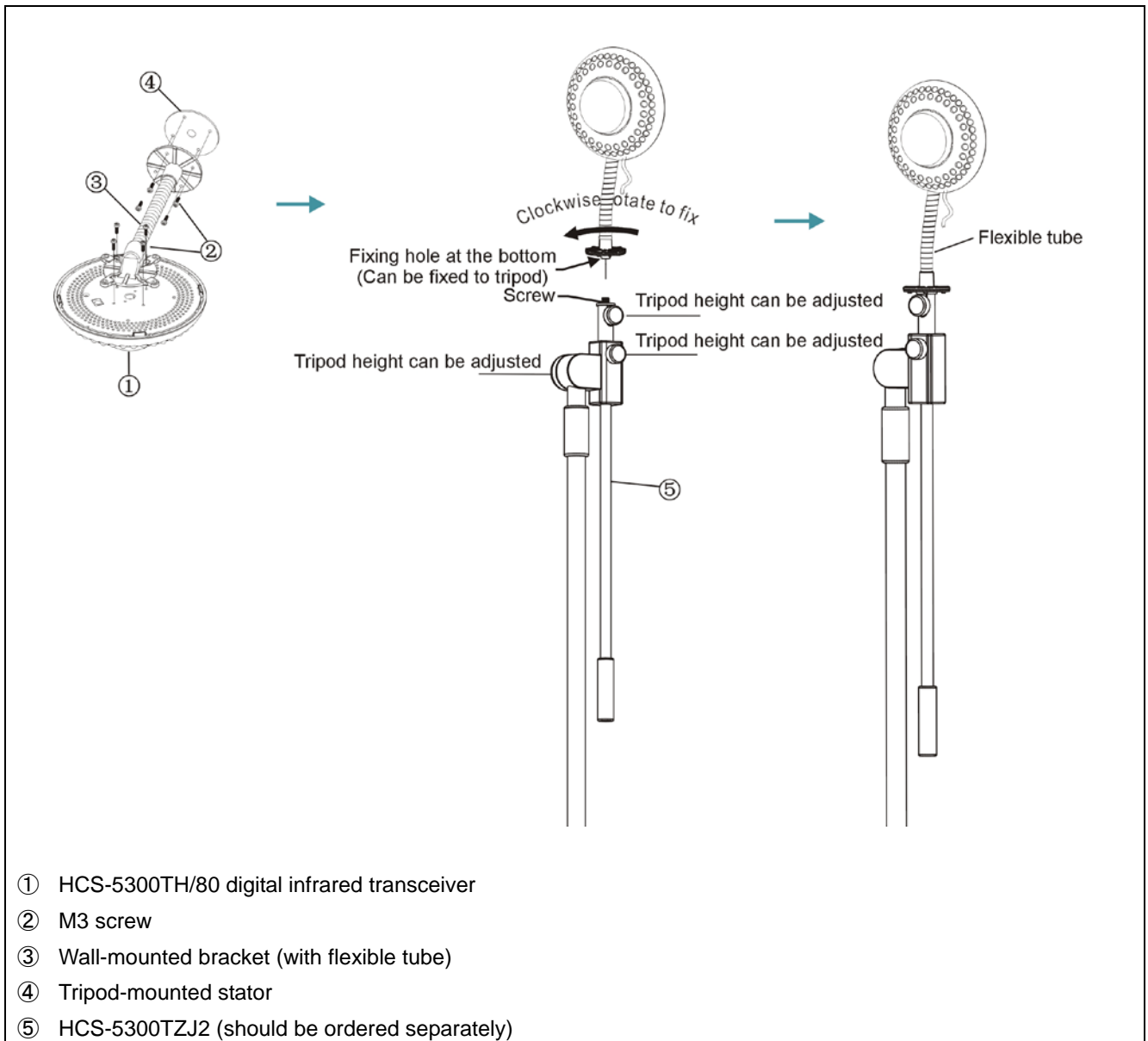

Figure 3.29 HCS-5300TH/80 digital infrared transceiver tripod mounted

Mounting steps:

Step 1: Fix the HCS-5300TH/80 digital infrared transceiver onto the wall-mounted bracket with M3 screws;

Step 2: Fix the tripod-mounted stator onto the other end of the wall-mounted bracket with M3 screws;

Step 3: Aim the mounting hole at the bottom of the tripod-mounted stator to the screw on the tripod;

Step 4: Fix it with clockwise rotation.

3.5.3.3 Wall mounted (Adjustable angle)

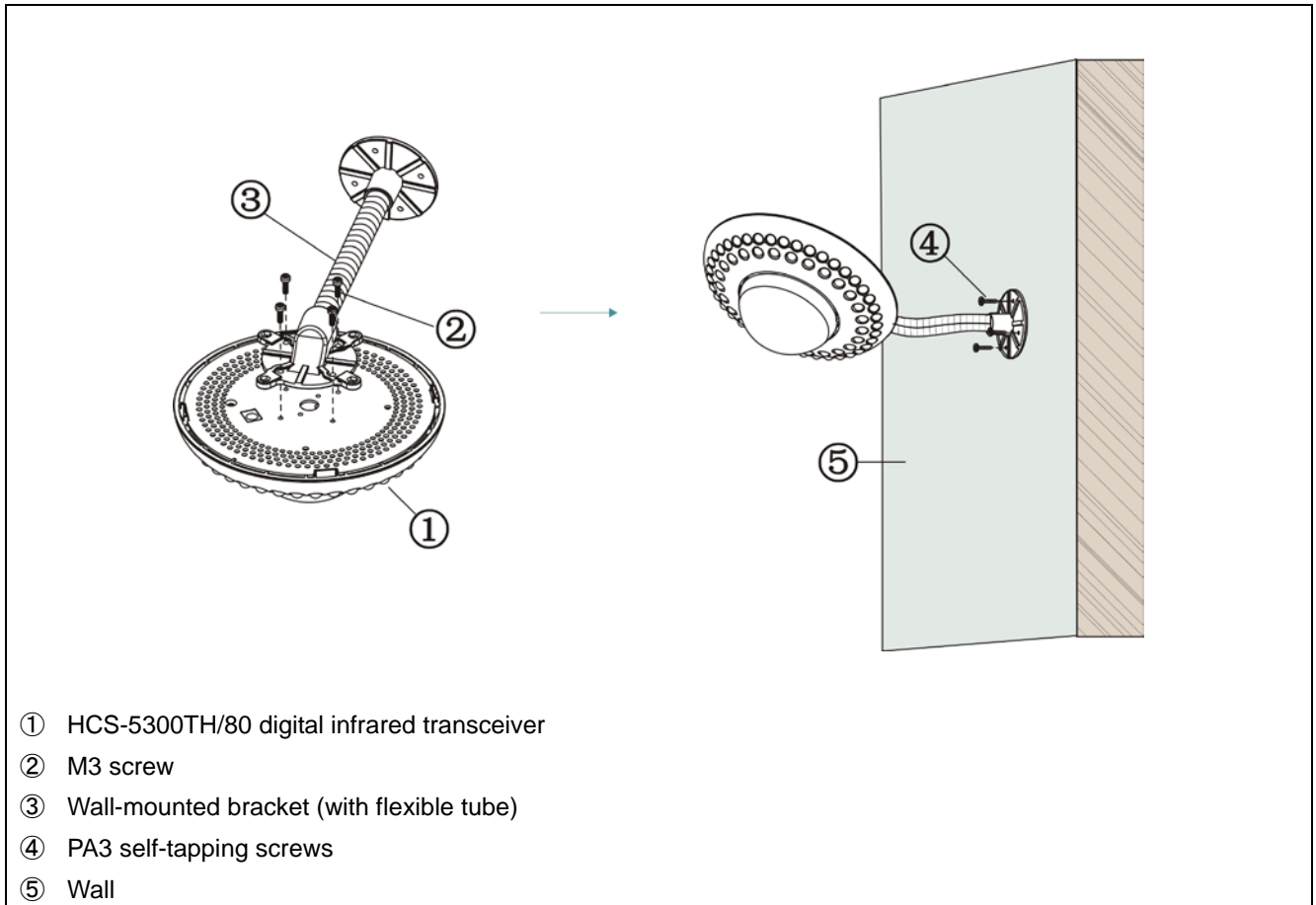

Figure 3.30 HCS-5300TH/80 digital infrared transceiver wall mounted

Mounting steps:

Step 1: Fix the HCS-5300TH/80 digital infrared transceiver onto the wall-mounted bracket with M3 screws;

Step 2: Position the wall-mounted bracket on the wall according to the installation location of the HCS-5300TH/80 and mark the positions of the drilling holes. Drill four holes (5 mm diameter, 30 mm depth) on the wall;

Step 3: Put the included rubber plugs into the mounting holes on the wall;

Step 4: Fix the wall-mounted bracket onto the wall with PA3 self-tapping screws.

WARNING:

☞ This installation method is applicable when the wall thickness is greater than the length of the rubber plug.

3.5.4 Installation of HCS-5300TWN/80

3.5.4.1 Ceiling mounted

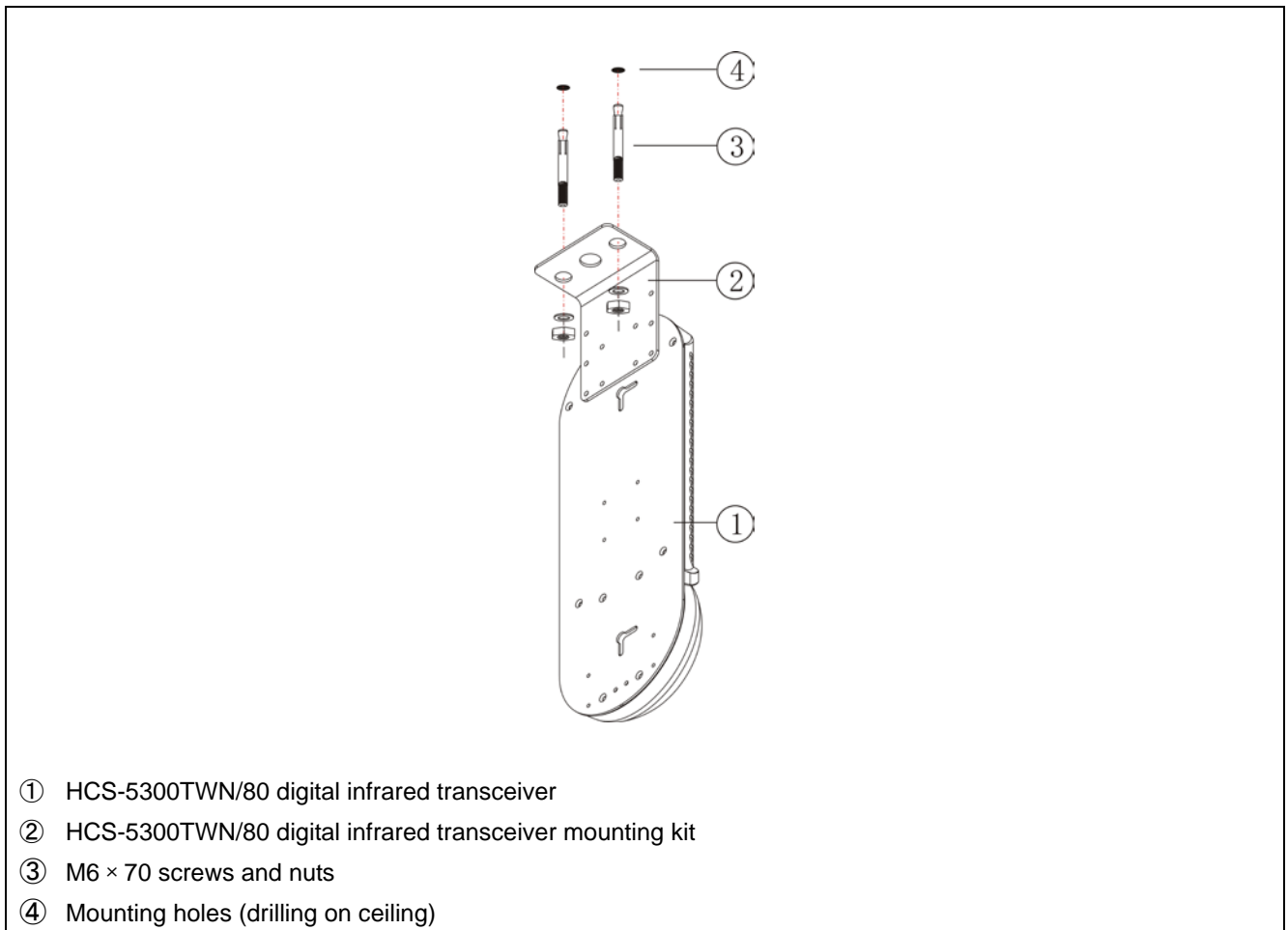

Figure 3.31 HCS-5300TWN/80 digital infrared transceiver ceiling mounted

Mounting steps:

Step 1: Install the mounting kit at the top of the HCS-5300TWN/80 Transceiver;

Step 2: Position the mounting kit on the ceiling according to the installation location of the HCS-5300TWN/80 and mark the positions of the drilling holes. Drill two holes (6 mm diameter, 50 mm depth) on the ceiling;

Step 3: Insert the screws into the mounting holes;

Step 4: Fix the mounting kit onto the ceiling with M6 nuts.

3.5.4.2 Tripod mounted

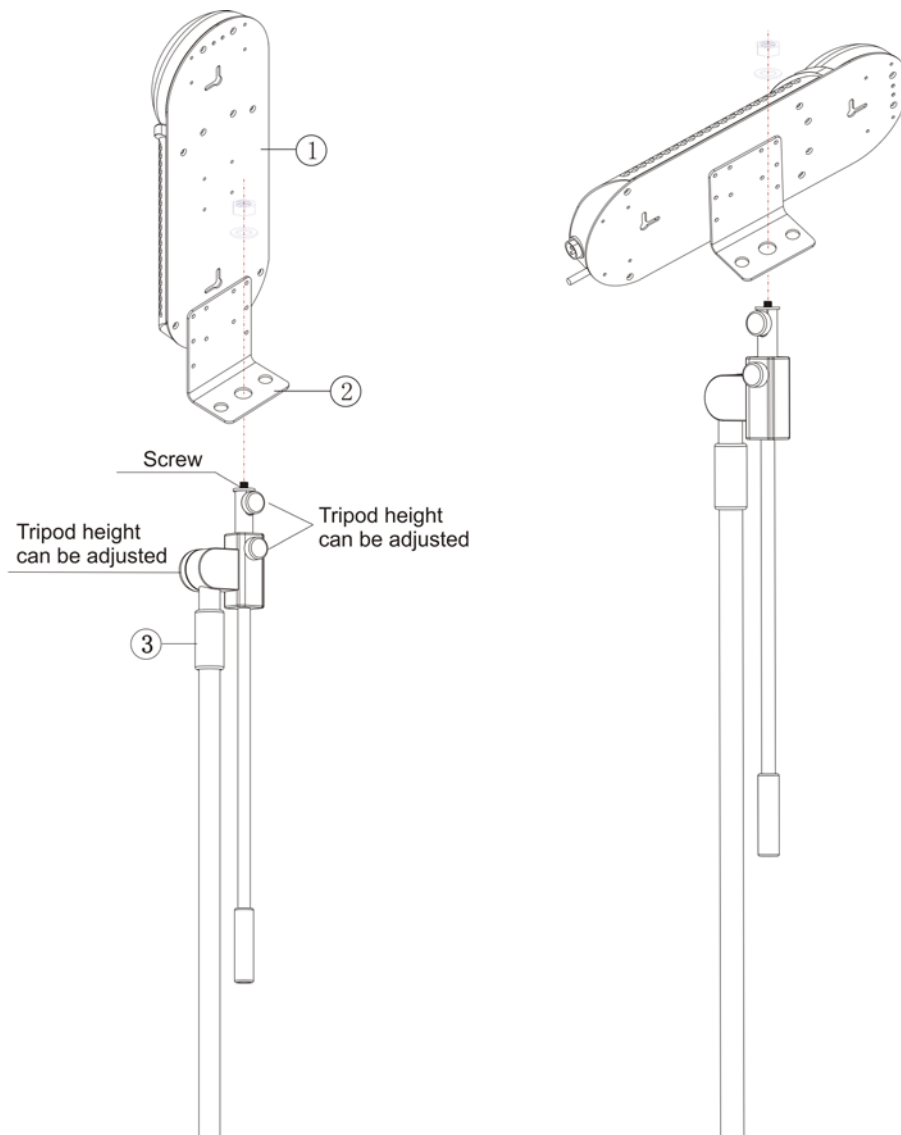

- ① HCS-5300TWN/80 digital infrared transceiver
- ② HCS-5300TWN/80 digital infrared transceiver mounting kit
- ③ HCS-5300TZJ2 (should be ordered separately)

Figure 3.32 HCS-5300TWN/80 digital infrared transceiver tripod mounted

Mounting steps:

Step 1: Fix the HCS-5300TWN/80 digital infrared transceiver onto the mounting kit (horizontal or longitudinal installation);

Step 2: Fasten the fixing holes of the mounting kit through the screw on the tripod and fix it with a nut.

3.5.4.3 Wall mounted 1 (Adjustable angle)

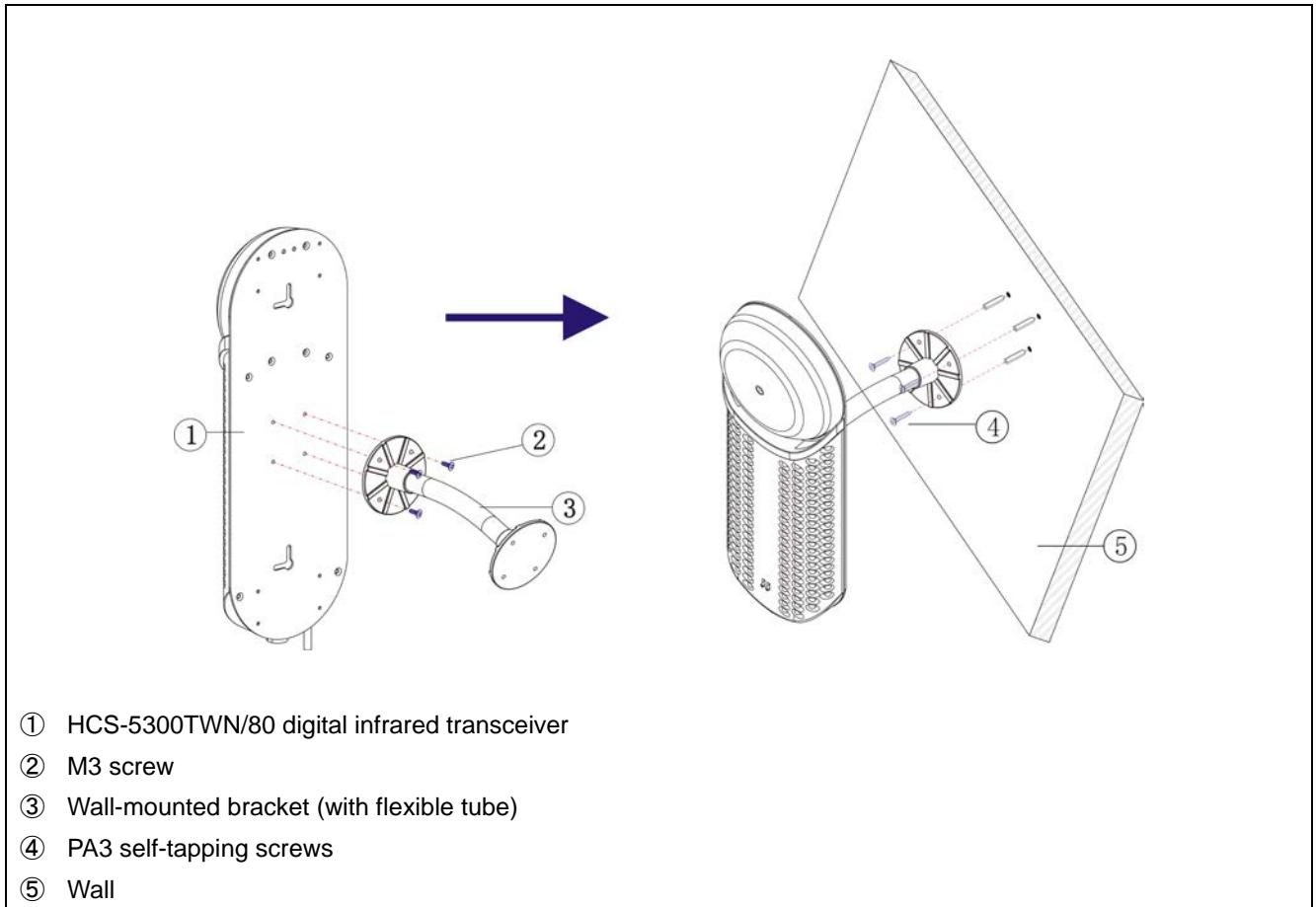

Figure 3.33 HCS-5300TWN/80 digital infrared transceiver wall mounted1

Mounting steps:

Step 1: Fix the HCS-5300TWN/80 digital infrared transceiver onto the wall-mounted bracket with M3 screws;

Step 2: Position the wall-mounted bracket on the wall according to the installation location of the HCS-5300TWN/80 and mark the positions of the drilling holes. Drill four holes (5 mm diameter, 30 mm depth) on the wall;

Step 3: Put the included rubber plugs into the mounting holes on the wall;

Step 4: Fix the wall-mounted bracket onto the wall with PA3 self-tapping screws.

WARNING:

☞ This installation method is applicable when the wall thickness is greater than the length of the rubber plug.

3.5.4.4 Wall mounted 2

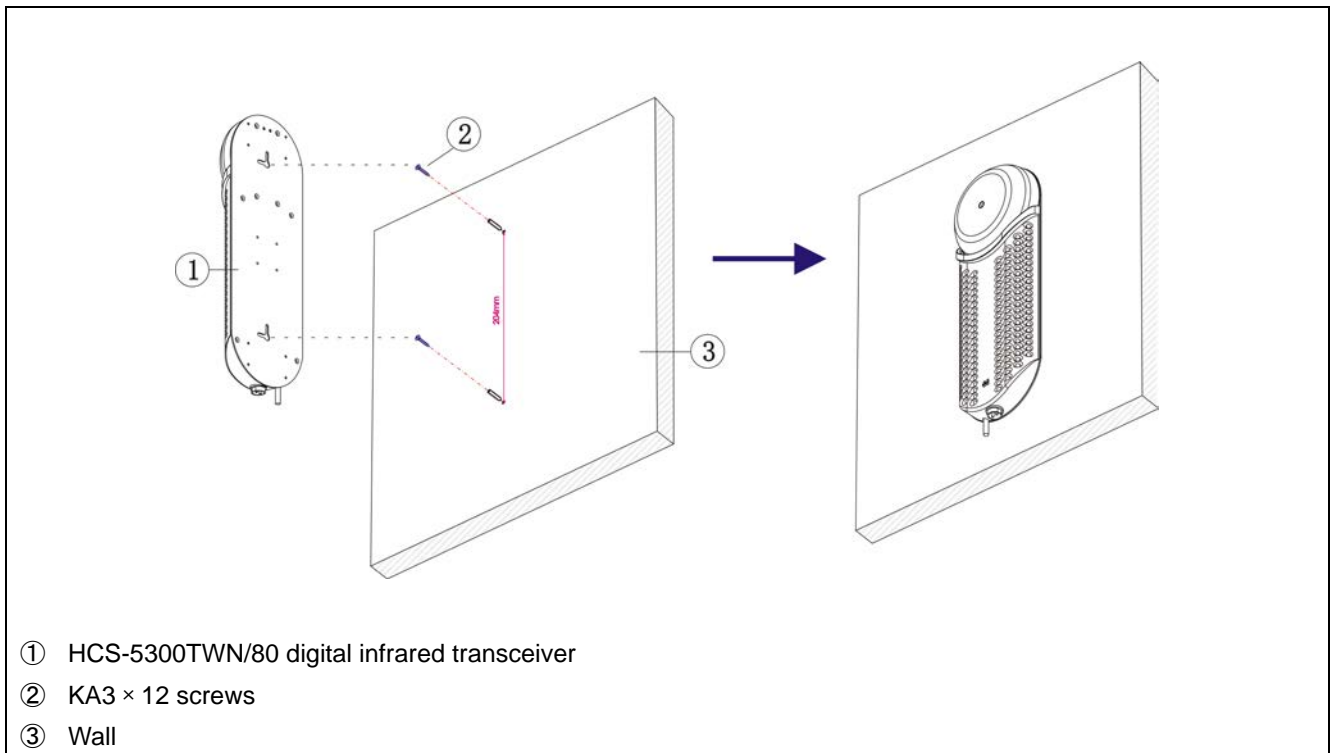

Figure 3.34 HCS-5300TWN/80 digital infrared transceiver wall mounted2

Mounting steps:

Step 1: Drill two holes (5 mm diameter, 30 mm depth, 204 mm spaced in vertical direction) on the wall according to installation location of the HCS-5300TWN/80;

Step 2: Put the included rubber plugs into the mounting holes on the wall;

Step 2: Put the KA3 screws into the included rubber plugs;

Step 4: Hang the HCS-5300TWN/80 digital infrared transceiver on the KA3 screw.

WARNING:

☞ This installation method is applicable when the wall thickness is greater than the length of the rubber plug.

3.6 Connecting to main unit

Connect the transceiver to the main unit with designated 6-pin 100 Mbps high speed cable.

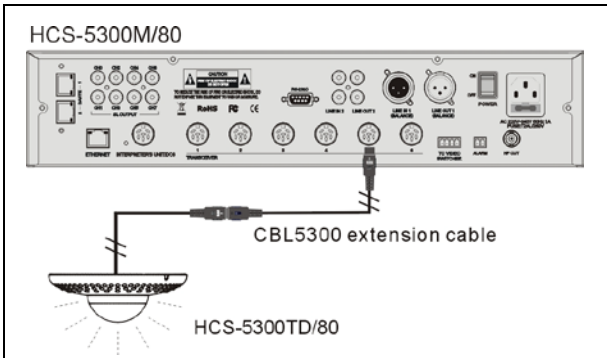

Figure 3.31 Digital infrared transceiver connecting to digital infrared wireless conference main unit

Note:

☞ The correctness of the cable connection can be ascertained if the indicating light on the transceiver is lighting up. If the indicating light is not on, cable connection failure or short circuit should be considered.

Chapter 4 HCS-5300/80 Series digital infrared wireless conference unit

4.1 Overview

HCS-5300/80 series digital infrared wireless conference units are the basic devices for the participators, divided into delegate unit and chairman unit with priority features. Different functions are available, depending on the conference unit type used. Functions include: listen, speak, LCD display, key press sign-in, vote, simultaneous interpretation, etc.

Types:

HCS-5300CE/80

Digital IR Wireless Chairman Unit (discussion, voting, 1+7 CHs, cooperates with HCS-5100Plus series can achieve 8 CHs simultaneous audio)

HCS-5300DE/80

Digital IR Wireless Delegate Unit (discussion, voting, 1+7 CHs, cooperates with HCS-5100Plus series can achieve 8 CHs simultaneous audio)

HCS-5301D/80

Digital IR Wireless Delegate Unit (discussion, 1+7 CHs, 2 channel selectors, dual predefined positions, cooperates with HCS-5100Plus series can achieve 8 CHs simultaneous audio)

HCS-5302C/80

Digital IR Wireless Chairman Unit (discussion)

HCS-5302D/80

Digital IR Wireless Delegate Unit (discussion)

4.2 Functions and indicating

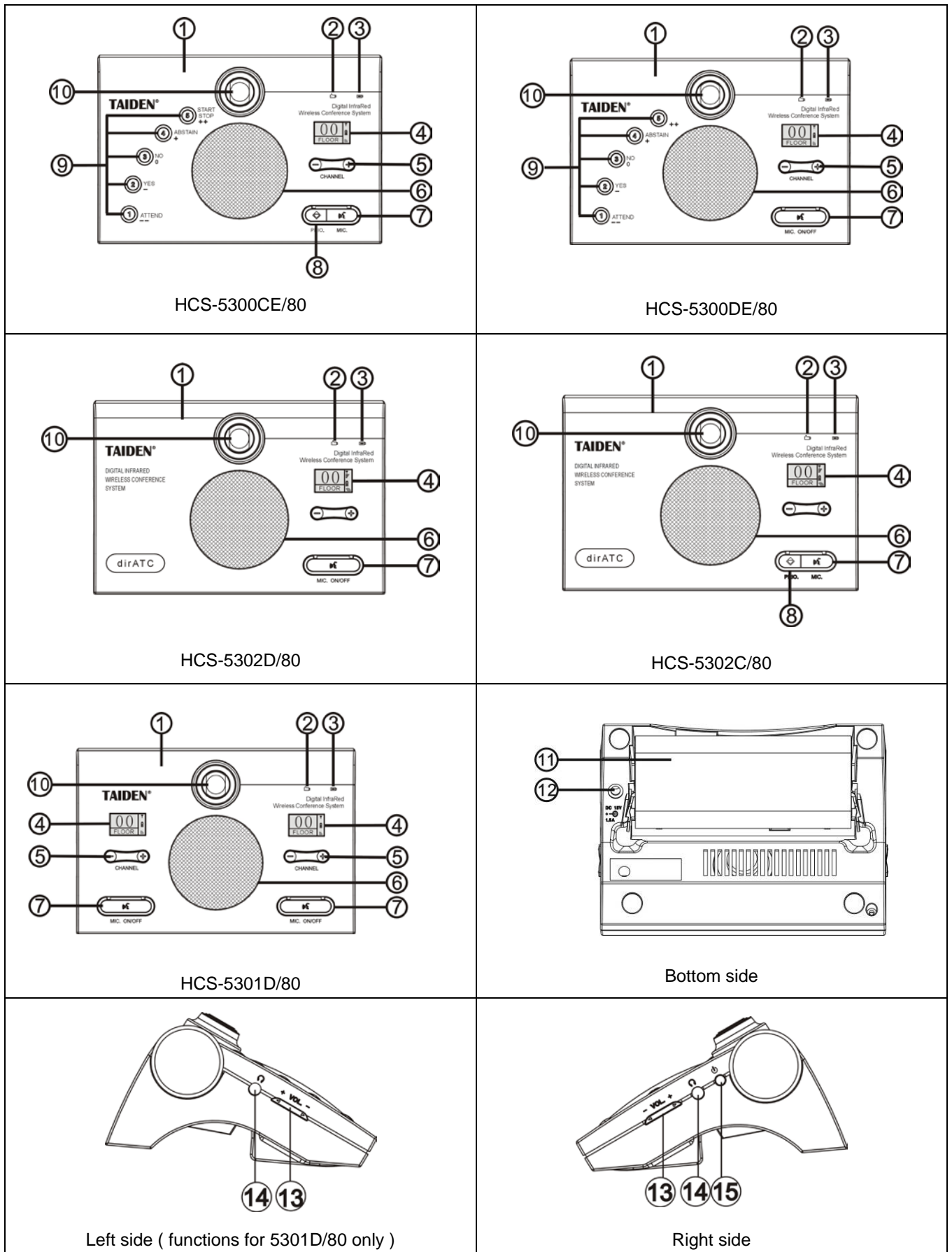

Figure 4.1 HCS-5300/80 series digital infrared wireless conference unit

Figure 4.1:

1. **Infrared transmitting/receiving glass** – at the frontage of the conference unit for transmitting/receiving infrared signals.

Note:

Please let no object block infrared signals from reaching the glass.

2. **Charging indicator**

3. **Fully charged indicator**

4. **LCD** – display for channel number, language name, signal icon, battery capacity and emission angle.

5. **Channel selector** (note: operable only if earphone is plugged)

6. **Built-in loudspeaker** – outputs floor audio; the volume is adjusted by the main unit or by PC application software. Mutes automatically when its microphone is switched on.

7. **Mic. On/Off button** (with indicating light around)

- **Chairman unit:** turn on/off mic if the number of active mic is less than 4
- **Delegate unit:**
 - a. Turn on/off mic in “Override” mode;
 - b. Turn on/off mic in “Open” mode if mic active limit number is not yet reached;
 - c. Turn off mic in “Voice” mode if mic is activated;
 - d. Request to speak/turn off mic in “Apply” mode.
- **Indication light** (according for the setting of the main unit):

Option	State	Mic.	Button
Green For Mic. On	Speaking	Green	Green
	Apply	Red	Red
	Voice (no speaking)	Off	Red
Red For Mic. On	Speaking	Red	Red
	Apply	Green	Green
	Voice (no speaking)	Off	Green

8. **Priority button** (for chairman unit only)

- If configured as “All mute”, all active microphones will be muted temporarily when the priority button is pressed and they will resume when the priority button is released;
- If configured as “All off”, all active microphones will be turned off automatically when the priority button is pressed;
- If the chairman microphone is not active, pressing

the priority button to activate it;

- If “Ring” mode was set as “On” in the main unit configuration, pressing this button will emit a ring tone.

9. **5 Multifunctional buttons** (with indicator around)

➤ **Sign-in /Candidate 1/Response-- (“ATTEND/1/- -”):**

- a. In sign-in mode, sign-in indicating light will blink, press this button to sign-in;
- b. In opinion poll state of voting mode, voting indicating light will blink, press this button to vote for candidate 1;
- c. In audience response state of voting mode, voting indicating light will blink, press this button to give a response “0” of “100” (“- -”).

➤ **Yes/ Candidate 2/Response- (“YES/2/-”):**

- a. In parliamentary state of voting mode, voting indicating light will blink, press this button to approve;
- b. In opinion poll state of voting mode, voting indicating light will blink, press this button to vote for candidate 2;
- c. In audience response state of voting mode, voting indicating light will blink, press this button to give a response “25” of “100” (“-”).

➤ **No/ Candidate 3/Response 0 (“NO/3/0”):**

- a. In parliamentary state of voting mode, voting indicating light will blink, press this button to oppose;
- b. In opinion poll state of voting mode, voting indicating light will blink, press this button to vote for candidate 3;
- e. In audience response state of voting mode, voting indicating light will blink, press this button to give a response “50” of “100” (“0”).

➤ **Abstain/ Candidate 4/Response+ (“ABSTAIN/4/+”):**

- a. In parliamentary state of voting mode, voting indicating light will blink, press this button to abstain;
- b. In opinion poll state of voting mode, voting indicating light will blink, press this button to vote for candidate 4;
- c. In audience response state of voting mode, voting indicating light will blink, press this button to give a response “75” of “100” (“+”).

➤ **Start/Stop/Candidate5/Response++**

(“START/STOP/5/++”):

- a. In opinion poll state of voting mode, voting indicating light will blink, press this button to vote for candidate 5;
- b. In audience response state of voting mode, voting indicating light will blink, press this button to give a response “100” of “100” (“++”);

10. Dismountable microphone socket

11. Position for Lithium battery

12. Power adapter interface

13. Earphone volume control

14. Earphone jack – Ø 3.5 mm stereo earphone jack

15. Power switch

4.3 Infrared service area

Infrared light is directional invisible light. Infrared wireless conference unit gets best sensitivity when it directly faces a transceiver. Every HCS-5300/80 series digital infrared wireless conference unit is equipped with infrared glass at its frontage to guarantee

maximum receiving angle.

In the vertical direction, the emission angle is 125° , and in the horizontal , the emission angle is 120° .

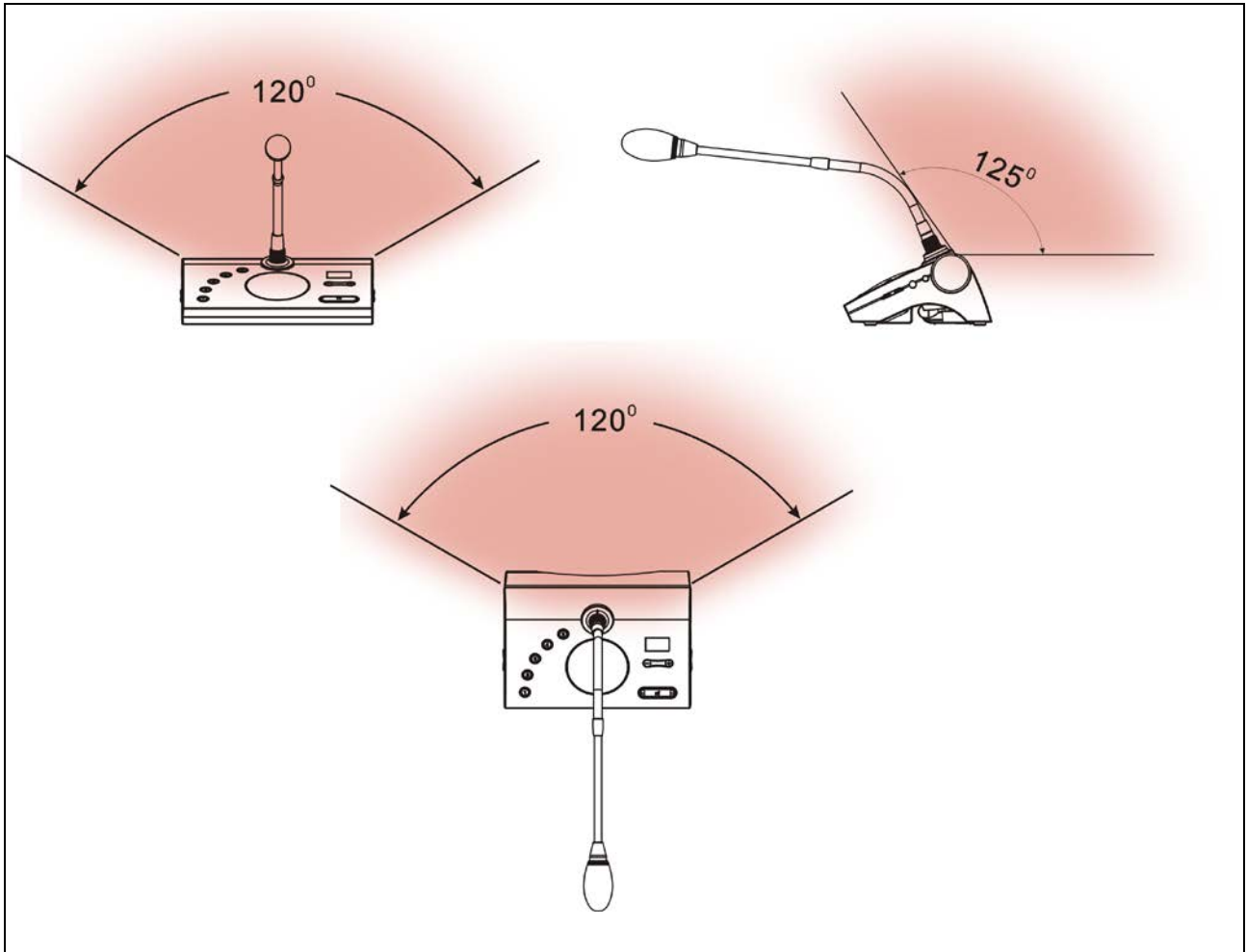

Figure 4.2 Coverage area of new generation digital infrared wireless conference unit

4.4 Precautions in using

- Avoid direct sunshine when using, otherwise it may cause signal blocking.

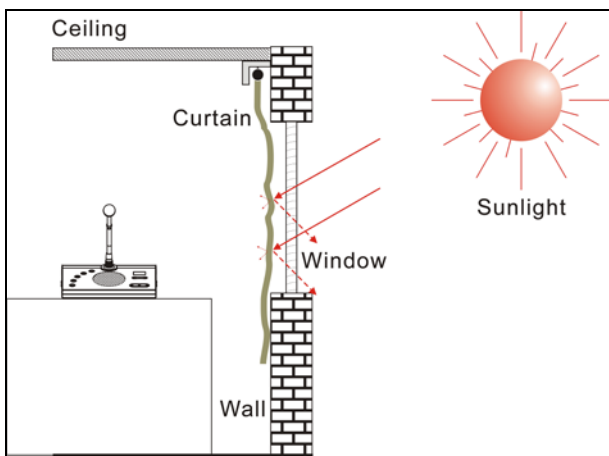

Figure 4.3 Close curtain to avoid direct sunshine

- The distance between adjacent conference units must be at least 0.5 meter; the distance between opposite conference units must be at least 0.8 meter.

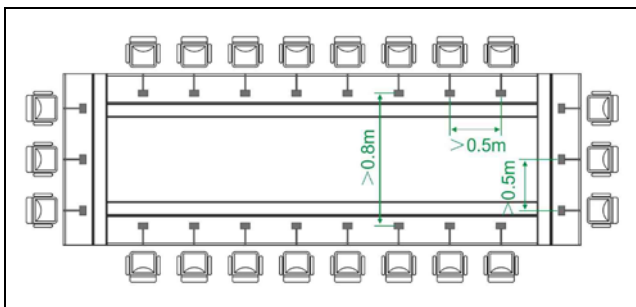

Figure 4.4 Distance between conference units

- The distance between the conference unit and the nearest transceiver must be at least 2 meters or more.

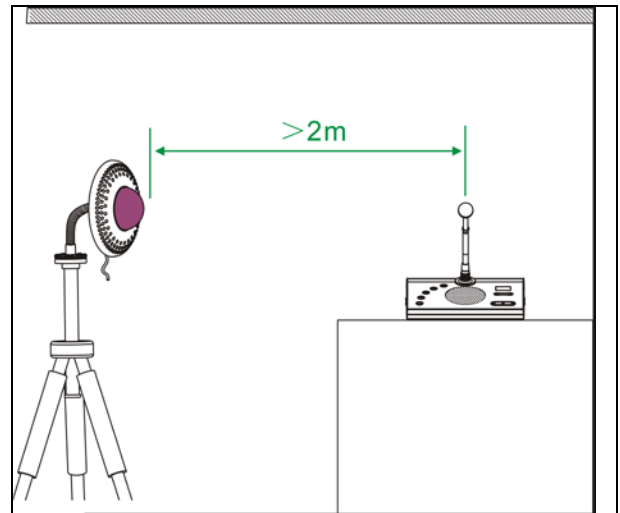

Figure 4.5 Distance between conference unit and transceiver

4.5 Operation

The operation of the chairman unit and the delegate unit will be introduced in detail in this section.

4.5.1 The operation of delegate unit

HCS-5300D/80 is taken as reference to introduce the operation of the digital infrared wireless delegate unit. HCS-5300D/80 delegate unit combines speaking, voting, channel selection with LED channel display all in one. Other types of delegate units feature all or part of the functions. The delegate unit can be set as VIP unit by software (TAIDEN Digital Conference System).

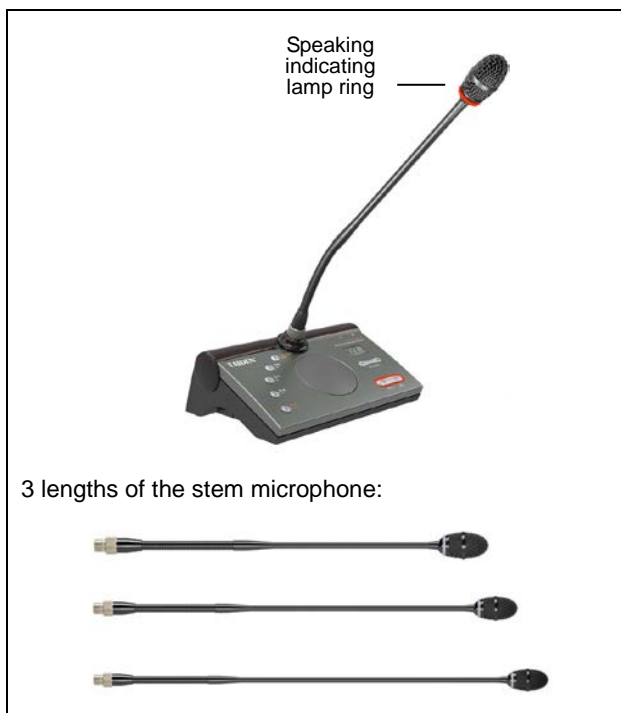

Figure 4.6 HCS-5300/80 series conference unit with microphone

1. Mic. active mode

The Mic. active mode can be set by the main unit configuration.

■ “Open”

- ◇ If the Mic. active limit (1/2/3/4) has not been reached, pressing the “Mic. On/Off” button will turn on the microphone;
- ◇ If the Mic. active limit has been reached, a further delegate microphone cannot be activated; the VIP/chairman microphones still can be activated when the total number of active microphone is less than 4 in the system.

■ “Override”

- ◇ If the Mic. active limit (1/2/3/4) has not been reached, pressing the “Mic. On/Off” button will turn on the microphone;
- ◇ If the Mic. active limit has been reached, the delegate microphone switched on first will be switched off first automatically (first in/first out) when another delegate microphone is activated. If the total number of active microphone is less than 4 in the system, the VIP/chairman microphones can be activated till the number reaches 4, and then if another VIP/chairman microphone is activated, the unit switched on first will be switched off first automatically (primarily switched off the delegate units and then the VIP/chairman units).

■ “Voice”

- ◇ If the Mic. active limit (1/2/3/4) has not been reached, the microphone will be activated when the delegate speaks into at a short distance. If the delegate does not speak in a set time, the microphone will be deactivated automatically.
- ◇ If the Mic. active limit has been reached, all other microphones cannot be activated unless one of the active microphones is turned off. The VIP/chairman microphones still can be activated when the total number of active microphone is less than 4 in the system.

■ “Apply” (application software needed)

- ◇ If the Mic. request limit (set up by PC) has not been reached, pressing the “Mic. On/Off” button can request to speak;
- ◇ If the Mic. active limit (1/2/3/4) has been reached, all other requests cannot be approved. The VIP/chairman unit still can be activated when the total number of active microphone is less than 4 in the system.

A camera can focus an activated microphone automatically (application software needed). Speaker's video can be exported to and displayed on large screen(s).

2. Vote (application software needed)

HCS-5300 application software can start voting.

- The voting button indicating lights of the conference unit start to blink, the delegate can press the voting button to vote;
- For “First key-press valid” voting, the delegate can vote only once, and his/her voting indicating lights will be deactivated after his/her voting;
- For “Last key-press valid” voting, the delegate can change his/her vote. When the delegate voted, the indicating light of his voted key will be activated and all other indicating lights will be deactivated. About 1 second later, all indicating lights will blink again, and the delegate may change his/her vote. His/her last voted key will be valid.

3. Channel select

- When the main unit is connected to an interpreter unit or when external audio and simultaneous interpretation function is operated, the channel selection function will be activated. To use the channel selection function, the earphone must be plugged in. When the earphone is plugged in, the interpretation languages can be selected by channel selector.
- When the earphone is pulled out, the conference unit will switch to floor audio channel automatically.

4. LCD display

■ Startup interface

The startup interface will be displayed on the LCD on startup, including:

Type
Version
ID

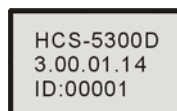

■ Channel number and language name display interface

After startup display, the floor audio channel is displayed, including: **Channel number**

Language name
Signal icon
Battery capacity



IR emission strength

If simultaneous interpretation function is operated and the earphone plugged in, simultaneous interpretation channels can be selected by the channel selector on the

delegate unit. The channel number and the language name will be displayed.

If the Mic IR strength automatic adjusting is enabled by main unit, the IR emission strength will be realtime displayed, the icon is shown as follow:

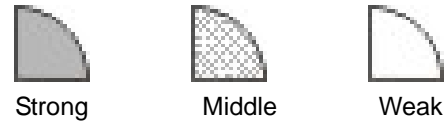

5. Key press sign-in (application software needed)

In sign-in mode, sign-in indicating light will blink. Press the “Attend” button to sign-in; the light extinguishes.

6. Volume control

- The built-in loudspeaker of the delegate unit can be adjusted by the main unit speaker volume adjust knob;
- The earphone volume can be adjusted by the volume control button on the delegate unit.

7. Charging

HCS-5300/80 conference unit can be charged with HCS-ADP15V adapter; or remove the lithium battery from the conference unit and be charged in the HCS-5300CHG/08 charging unit. When charging by the adapter, the Charging Indicator and Fully Charged Indicator are for indication of the current power status and battery status:

	Charging indicator	Fully charged indicator
Charging	On	-
Full	-	On

4.5.2 The operation of chairman unit

The chairman unit features the functions of a delegate unit and in addition priority function:

- If the priority mode is set as “All mute” in the main unit configuration, all active conference units will be muted when the priority button on the chairman unit is pressed and return active when the priority button on the chairman unit is released;
- If the priority mode is set as “All off” in the main unit configuration, all active conference units will be turned off automatically when the priority button on the chairman unit is pressed.

Note:

- ☞ When there is more than one chairman unit in a system and if one chairman is pressing the priority key, the priority keys of the remaining chairman units will be inoperable temporarily.

Chapter 5 HCS-5380 Series digital infrared wireless conference unit

5.1 Overview

HCS-5380 series digital infrared wireless conference units are the basic devices for the participators, divided into delegate unit and chairman unit with priority features. Different functions are available, depending on the conference unit type used. Functions include: listen, speak, OLED display, key press sign-in, vote, simultaneous interpretation, etc.

Types:

HCS-5380CVS

Digital IR Wireless Chairman Unit (discussion, voting, 1+7 CHs, cooperates with HCS-5100Plus series can achieve 8 CHs simultaneous audio)

HCS-5380C

Digital IR Wireless Chairman Unit (discussion)

HCS-5380DVS

Digital IR Wireless Delegate Unit (discussion, voting, 1+7 CHs, cooperates with HCS-5100Plus series can achieve 8 CHs simultaneous audio)

HCS-5380DDS

Digital IR Wireless Delegate Unit (discussion, 1+7 CHs, 2 channel selectors, dual predefined positions, cooperates with HCS-5100Plus series can achieve 8 CHs simultaneous audio)

HCS-5380DS

Digital IR Wireless Delegate Unit (discussion, 1+7 CHs, cooperates with HCS-5100Plus series can achieve 8 CHs simultaneous audio,)

HCS-5380D

Digital IR Wireless Delegate Unit (discussion)

5.2 Functions and indicating

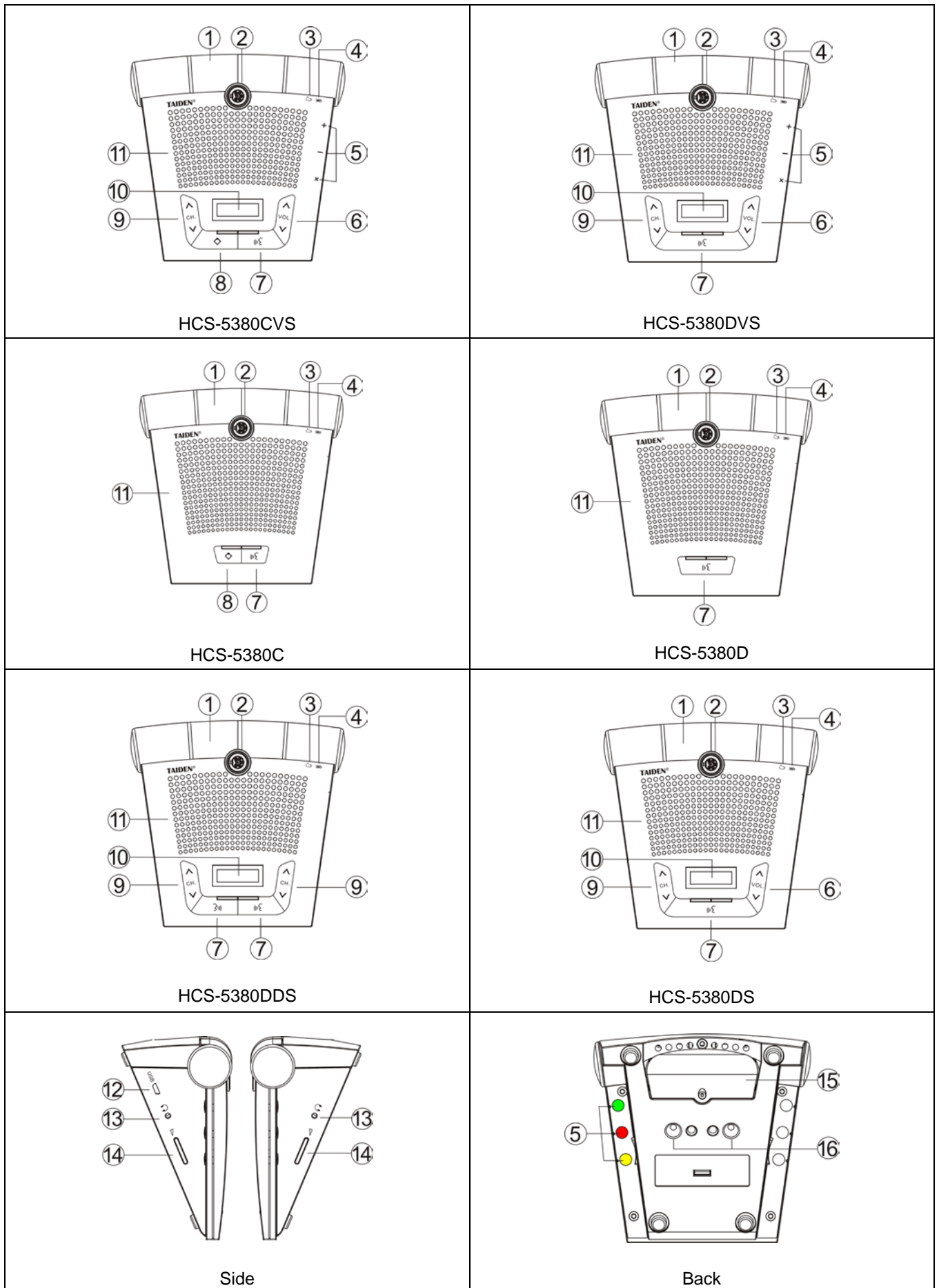

Figure 5.1 HCS-5380 series digital infrared wireless conference unit

Figure 5.1:

1. Infrared transmitting/receiving glass – at the frontage of the conference unit for transmitting/receiving infrared signals.

Note:
 ☞ Please let no object block infrared signals from reaching the glass.

2. Dismountable microphone socket

3. Charging indicator

4. Battery indicator

5. 3 Function buttons (only for HCS-5380CVS/DVS)

Function	+	-	×
Sign-in	Any button		
Voting	Yes	No	Abstain
Opinion poll	1	2	3

6. Earphone volume control

7. Mic. On/Off button (with indicating light around)

- Press the button for power on and keep pressing the button for power off the conference unit
- **Chairman unit:** turn on/off mic if the number of active mic is less than 4
- **Delegate unit:**
 - a. Turn on/off mic in “Override” mode;
 - b. Turn on/off mic in “Open” mode if mic active limit number is not yet reached;
 - c. Turn off mic in “Voice” mode if mic is activated;
 - d. Request to speak/turn off mic in “Apply” mode.
- **Indication light** (according for the setting of the main unit):

Option	State	Mic.	Button
Green For Mic. On	Speaking	Green	Green
	Apply	Red	Red
	Voice (no speaking)	Off	Red
Red For Mic. On	Speaking	Red	Red
	Apply	Green	Green
	Voice (no speaking)	Off	Green

8. Priority button (for chairman unit only)

- If configured as “All mute”, all active microphones will be muted temporarily when the priority button is pressed and they will resume when the priority button is released;
- If configured as “All off”, all active microphones will be turned off automatically when the priority button is pressed;
- If the chairman microphone is not active, pressing the priority button to activate it;
- If “Ring” mode was set as “On” in the main unit configuration, pressing this button will emit a ring tone.

9. Channel selector (note: operable only if earphone is plugged)

10. OLED with screen savers– display for channel number, language name, battery capacity and earphone volume.

11. Built-in loudspeaker – outputs floor audio; the volume is adjusted by the main unit or by PC application software. Mutes automatically when its microphone is switched on.

12. USB interface

- For upgrade
- For connecting to adapt to charge the unit

13. Earphone jack (HCS-5380DDS with two jacks) – Ø 3.5 mm stereo earphone jack

14. Earphone volume button (HCS-5380DDSwit with two buttons)

15. Battery slot

16. Charging contacts

5.3 Infrared service area

Infrared light is directional invisible light. Infrared wireless conference unit gets best sensitivity when it directly faces a transceiver. Every HCS-5380 series digital infrared wireless conference unit is equipped with infrared glass at its frontage to guarantee maximum receiving angle.

In the vertical direction, the emission angle is 125° , and in the horizontal , the emission angle is 120° .

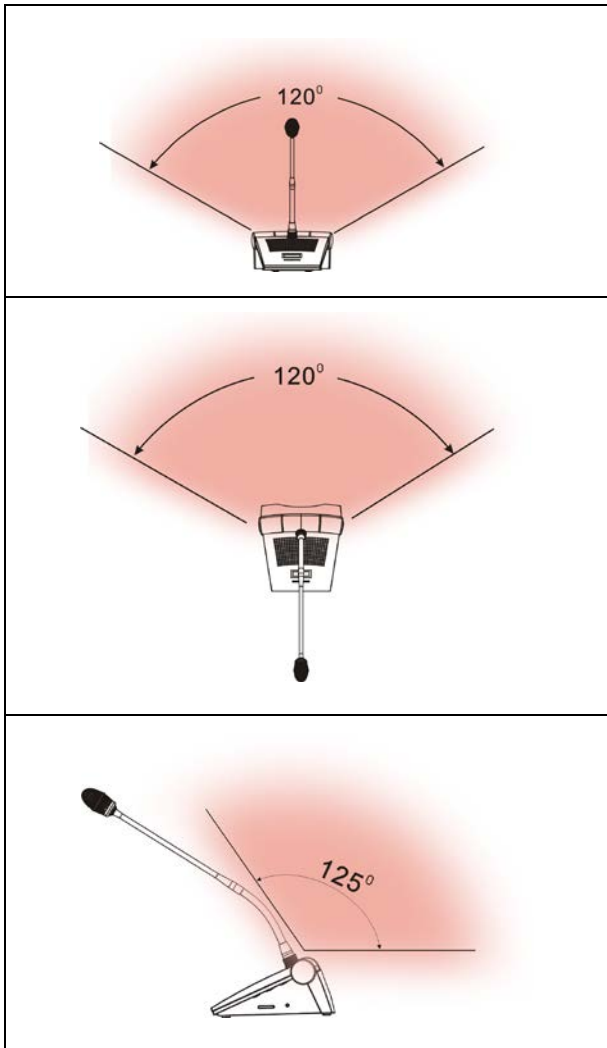

Figure 5.2 Coverage area of digital infrared wireless conference unit

5.4 Precautions in using

- **Avoid direct sunshine when using, otherwise it may cause signal blocking.**

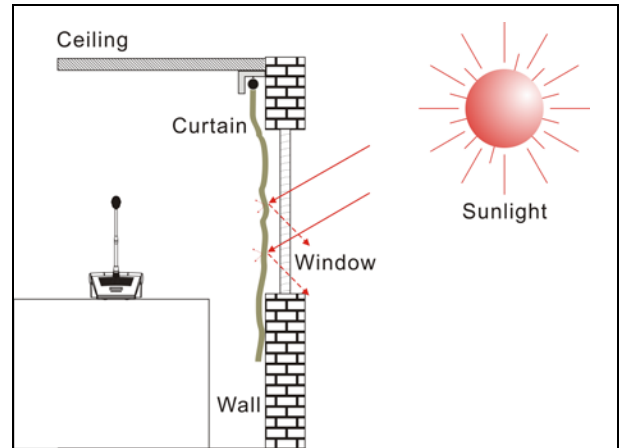

Figure 5.3 Close curtain to avoid direct sunshine

- **The distance between adjacent conference units must be at least 0.5 meter; the distance between opposite conference units must be at least 0.8 meter.**

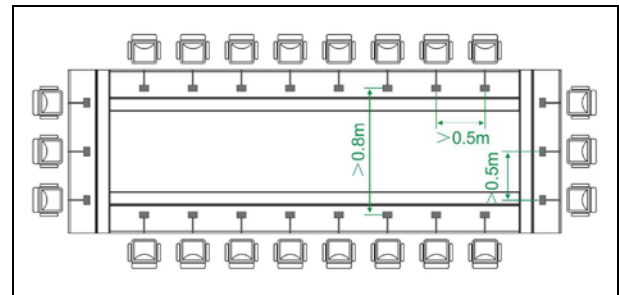

Figure 5.4 Distance between conference units

- **The distance between the conference unit and the nearest transceiver must be at least 2 meters or more.**

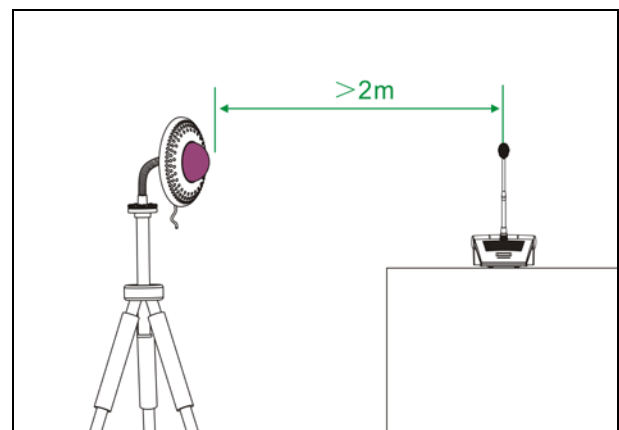

Figure 5.5 Distance between conference unit and transceiver

5.5 Operation

The operation of the chairman unit and the delegate unit will be introduced in detail in this section.

5.5.1 The operation of delegate unit

HCS-5380DVS is taken as reference to introduce the operation of the digital infrared wireless delegate unit. HCS-5380D series delegate unit combines speaking, voting, channel selection with OLED channel display all in one. Other types of delegate units feature all or part of the functions. The delegate unit can be set as VIP unit by software (TAIDEN Digital Conference System).

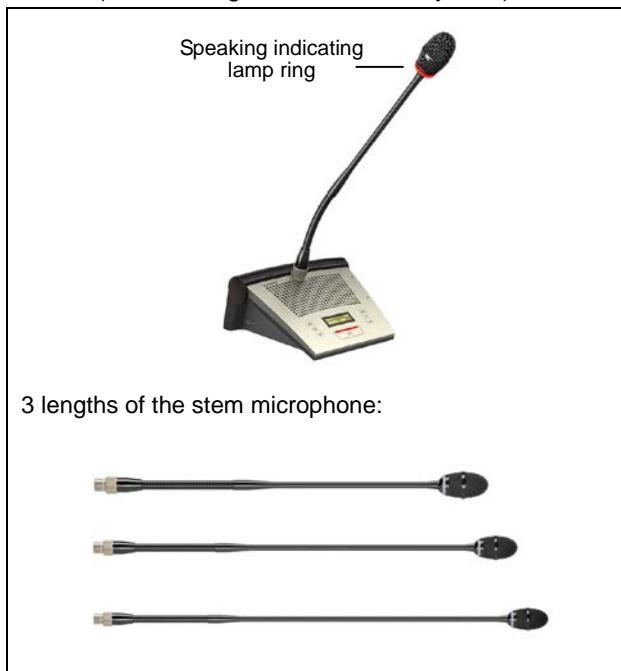

Figure 5.6 HCS-5380 series conference unit with microphone

1. Power on/off

Press the microphone on/off button for power on and keep pressing the button for power off the conference unit.

2. Key press sign-in (application software needed)

In sign-in mode, OLED displays "PRESENTING". Press the "+", "-", or "x" button to sign in and the OLED displays "PRESENTED" when succeed.

3. Mic. active mode

The Mic. active mode can be set by the main unit configuration.

■ "Open"

- ◇ If the Mic. active limit (1/2/3/4) has not been reached, pressing the "Mic. On/Off" button will turn on the microphone;
- ◇ If the Mic. active limit has been reached, a further delegate microphone cannot be activated; the VIP/chairman microphones still can be activated when the total number of active microphone is less than 4 in the system.

■ "Override"

- ◇ If the Mic. active limit (1/2/3/4) has not been reached, pressing the "Mic. On/Off" button will turn on the microphone;
- ◇ If the Mic. active limit has been reached, the delegate microphone switched on first will be switched off first automatically (first in/first out) when another delegate microphone is activated. If the total number of active microphone is less than 4 in the system, the VIP/chairman microphones can be activated till the number reaches 4, and then if another VIP/chairman microphone is activated, the unit switched on first will be switched off first automatically (primarily switched off the delegate units and then the VIP/chairman units).

■ "Voice"

- ◇ If the Mic. active limit (1/2/3/4) has not been reached, the microphone will be activated when the delegate speaks into at a short distance. If the delegate does not speak in a set time, the microphone will be deactivated automatically.
- ◇ If the Mic. active limit has been reached, all other microphones cannot be activated unless one of the active microphones is turned off. The VIP/chairman microphones still can be activated when the total number of active microphone is less than 4 in the system.

Note:

When the “One touch turn on mic.” setting of main unit is enabled, HCS-5380C/D can also be turn on via pressing the “Mic. On/Off” button if the Mic. active limit hasn’t been reached. These units must be turn off via pressing the “Mic. On/Off” button as well.

■ **“Apply” (application software needed)**

- ◇ If the Mic. request limit (set up by PC) has not been reached, pressing the “Mic. On/Off” button can request to speak;
- ◇ If the Mic. active limit (1/2/3/4) has been reached, all other requests cannot be approved. The VIP/chairman unit still can be activated when the total number of active microphone is less than 4 in the system.

A camera can focus an activated microphone automatically (application software needed). Speaker’s video can be exported to and displayed on large screen(s).

4. Vote (application software needed)

HCS-5380 application software can start voting.

- The OLED displays the options, the delegate can press the voting button to vote;

Function	+	-	×
Voting	Yes	No	Abstain
Opinion poll	1	2	3

- For “First key-press valid” voting, the delegate can vote only once, and the selected option will be high-lighted;
- For “Last key-press valid” voting, the delegate can change his/her vote. His/her last voted key will be valid.

5. Channel select

- When the main unit is connected to an interpreter unit or when external audio and simultaneous interpretation function is operated, the channel selection function will be activated. To use the channel selection function, the earphone must be plugged in. When the earphone is plugged in, the

interpretation languages can be selected by channel selector.

- When the earphone is pulled out, the conference unit will switch to floor audio channel automatically.

6. OLED display

The startup interface will be displayed on the OLED on startup, including: channel number, battery capacity, earphone volume and language name.



If simultaneous interpretation function is operated and the earphone plugged in, simultaneous interpretation channels can be selected by the channel selector on the left side of the OLED. The channel number and the language name will be displayed.



7. Volume control

- a) The built-in loudspeaker of the delegate unit can be adjusted by the main unit speaker volume adjust knob;
- b) The earphone volume can be adjusted by the volume control button on the front or side of the delegate unit.

8. Charging

HCS-5380C/D conference unit can be charged with TES-ADP5V adapter, or be charged in HCS-5380CHG/06 charging unit. When charging by the adapter, the charging indicator lights up for indication of the current power status and battery status:

	Charging indicator
Charging	Flash
Full	On

After power on, the battery status will be indicated via the battery indicator:

	Battery indicator
Charging	On
Full	Flash fast

The other conference units will display the power status and battery status on the OLED.

5.5.2 The operation of chairman unit

The chairman unit features the functions of a delegate unit and in addition priority function:

- If the priority mode is set as “All mute” in the main unit configuration, all active conference units will be muted when the priority button on the chairman unit is pressed and return active when the priority button on the chairman unit is released;
- If the priority mode is set as “All off” in the main unit configuration, all active conference units will be turned off automatically when the priority button on the chairman unit is pressed.

Note:

- ☞ When there is more than one chairman unit in a system and if one chairman is pressing the priority key, the priority keys of the remaining chairman units will be inoperable temporarily.

Chapter 6 HCS-5381 Series digital infrared wireless conference unit

6.1 Overview

HCS-5381 series digital infrared wireless conference units are the basic devices for the participators, divided into delegate unit and chairman unit with priority features.

Types:

HCS-5381RC

Digital IR Wireless Chairman Unit (rectangular columnar metal microphone, discussion)

HCS-5381RD

Digital IR Wireless Delegate Unit (rectangular columnar metal microphone, discussion)

HCS-5381C

Digital IR Wireless Chairman Unit (discussion)

HCS-5381D

Digital IR Wireless Delegate Unit (discussion)

6.2 Functions and indicating

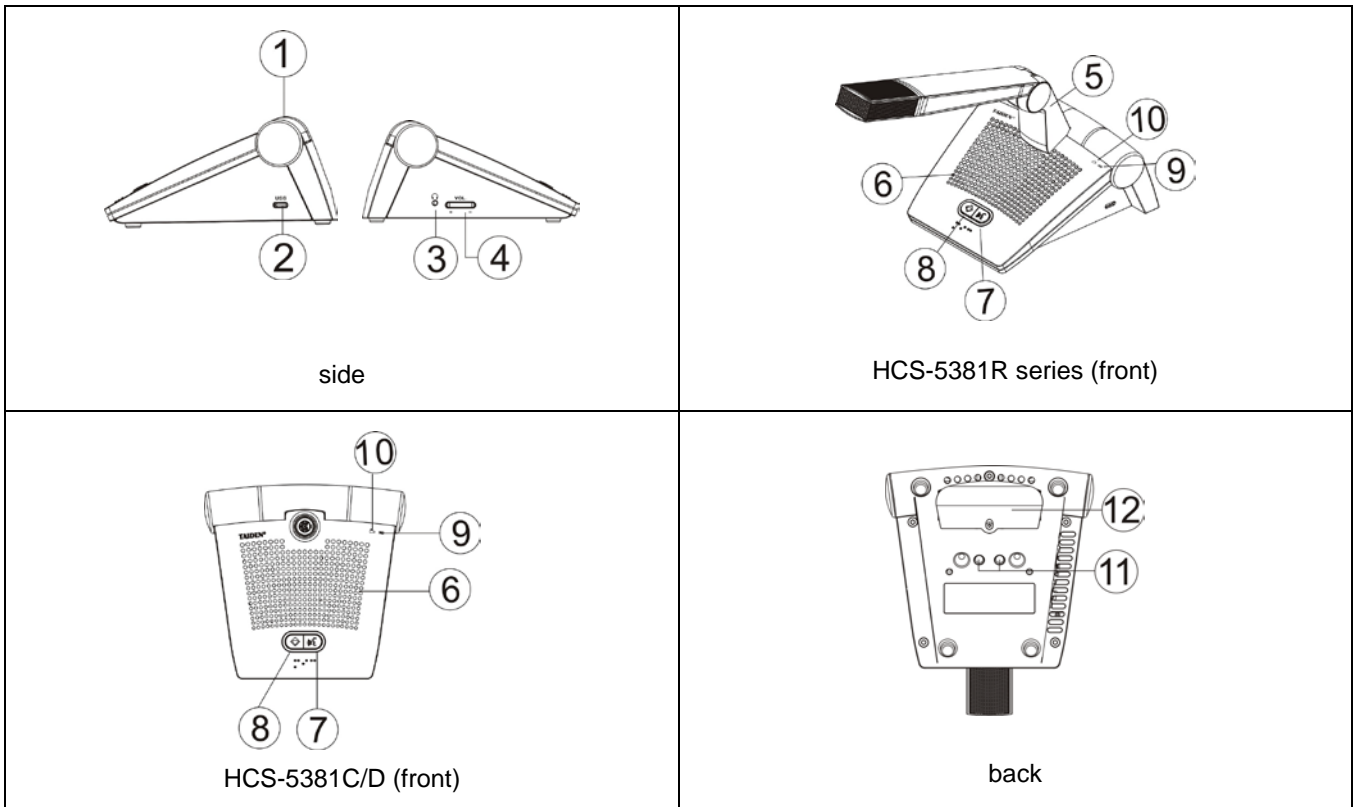

Figure 6.1 HCS-5381 series digital infrared wireless conference unit

Figure 6.1:

1. **Infrared transmitting/receiving glass** – at the frontage of the conference unit for transmitting/receiving infrared signals.

Note:
 ☞ Please let no object block infrared signals from reaching the glass.

2. **USB interface**

- For upgrade
- For connecting to adapt to charge the unit

3. **Earphone jack** – Ø 3.5 mm stereo earphone jack

4. **Earphone volume button**

5. **Rectangular columnar metal microphone (HCS-5381R series)**

Dismountable microphone socket (HCS-5381C/D)

6. **Built-in loudspeaker** – outputs floor audio; the volume is adjusted by the main unit or by PC application software. Mutes automatically when its microphone is switched on.

7. **Mic. On/Off button** (with indicating light around)

- Press the button for power on and keep pressing the button for power off the conference unit

- **Chairman unit:** turn on/off mic if the number of active mic is less than 4
- **Delegate unit:**
 - a. Turn on/off mic in “Override” mode;
 - b. Turn on/off mic in “Open” mode if mic active limit number is not yet reached;
 - c. Turn off mic in “Voice” mode if mic is activated;
 - d. Request to speak/turn off mic in “Apply” mode.
- **Indication light** (according for the setting of the main unit):

Option	State	Mic.	Button
Green For Mic. On	Speaking	Green	Green
	Apply	Red	Red
	Voice (no speaking)	Off	Red
Red For Mic. On	Speaking	Red	Red
	Apply	Green	Green
	Voice (no speaking)	Off	Green

8. Priority button (for chairman unit only)

- If configured as “All mute”, all active microphones will be muted temporarily when the priority button is pressed and they will resume when the priority button is released;
- If configured as “All off”, all active microphones will be turned off automatically when the priority button is pressed;
- If the chairman microphone is not active, pressing the priority button to activate it;
- If “Ring” mode was set as “On” in the main unit configuration, pressing this button will emit a ring tone.

9. Battery indicator

10 .Charging indicator

11. Charging contacts

12. Battery slot

6.3 Infrared service area

Infrared light is directional invisible light. Infrared wireless conference unit gets best sensitivity when it directly faces a transceiver. Every HCS-5381 series digital infrared wireless conference unit is equipped with infrared glass at its frontage to guarantee maximum receiving angle.

In the vertical direction, the emission angle is 125° , and in the horizontal, the emission angle is 120° .

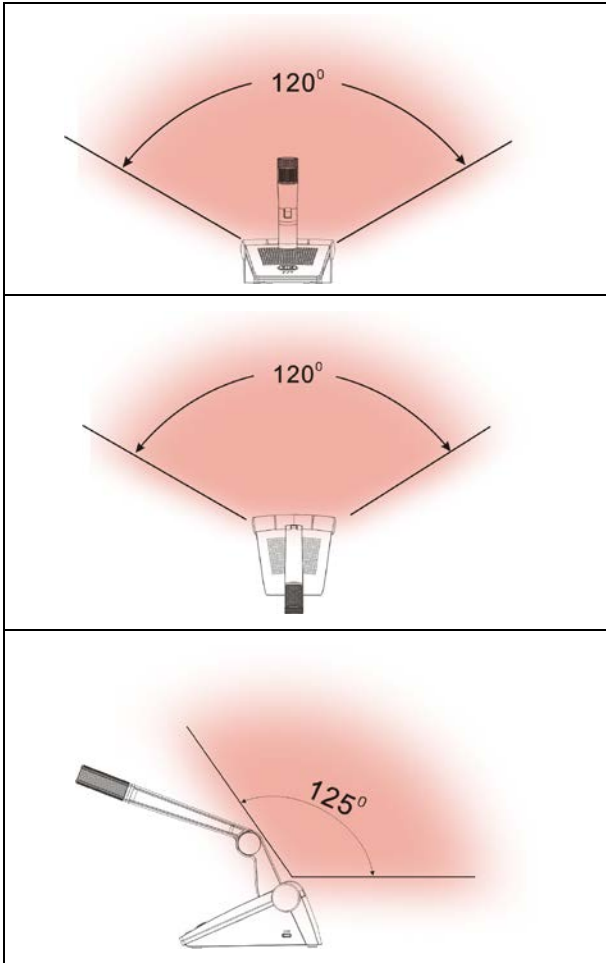

Figure 6.2 Coverage area of digital infrared wireless conference unit

6.4 Precautions in using

- **Avoid direct sunshine when using, otherwise it may cause signal blocking.**

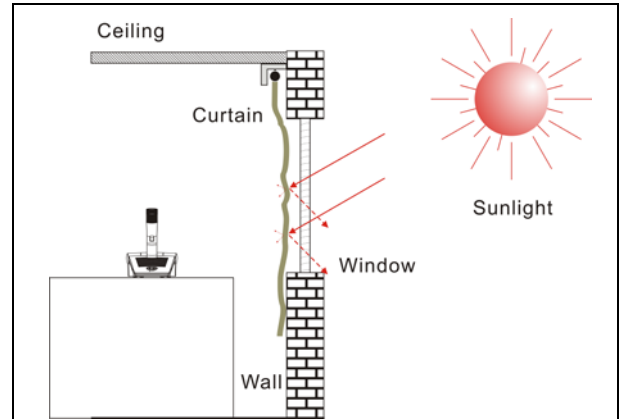

Figure 6.3 Close curtain to avoid direct sunshine

- **The distance between adjacent conference units must be at least 0.5 meter; the distance between opposite conference units must be at least 0.8 meter.**

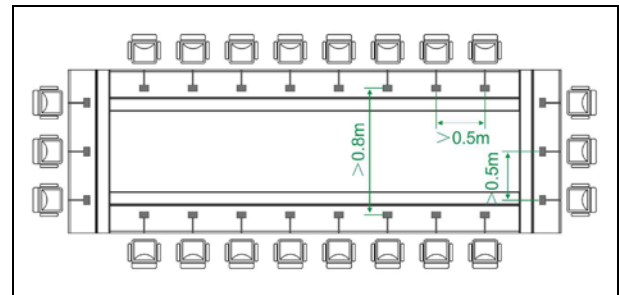

Figure 6.4 Distance between conference units

- **The distance between the conference unit and the nearest transceiver must be at least 2 meters or more.**

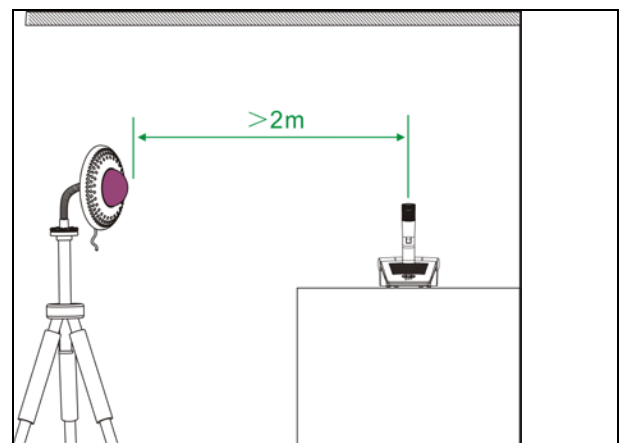

Figure 6.5 Distance between conference unit and transceiver

6.5 Operation

The operation of the chairman unit and the delegate unit will be introduced in detail in this section.

6.5.1 The operation of delegate unit

1. Power on/off

Press the microphone on/off button for power on and keep pressing the button for power off the conference unit.

2. Mic. active mode

The Mic. active mode can be set by the main unit configuration.

■ “Open”

- ◇ If the Mic. active limit (1/2/3/4) has not been reached, pressing the “Mic. On/Off” button will turn on the microphone;
- ◇ If the Mic. active limit has been reached, a further delegate microphone cannot be activated; the VIP/chairman microphones still can be activated when the total number of active microphone is less than 4 in the system.

■ “Override”

- ◇ If the Mic. active limit (1/2/3/4) has not been reached, pressing the “Mic. On/Off” button will turn on the microphone;
- ◇ If the Mic. active limit has been reached, the delegate microphone switched on first will be switched off first automatically (first in/first out) when another delegate microphone is activated. If the total number of active microphone is less than 4 in the system, the VIP/chairman microphones can be activated till the number reaches 4, and then if another VIP/chairman microphone is activated, the unit switched on first will be switched off first automatically (primarily switched off the delegate units and then the VIP/chairman units).

■ “Voice”

- ◇ If the Mic. active limit (1/2/3/4) has not been reached, the microphone will be activated when the delegate speaks into at a short distance. If the delegate does not speak in a set time, the microphone will be deactivated automatically.

- ◇ If the Mic. active limit has been reached, all other microphones cannot be activated unless one of the active microphones is turned off. The VIP/chairman microphones still can be activated when the total number of active microphone is less than 4 in the system.

Note:

- ☞ When the “One touch turn on mic.” setting of main unit is enabled, HCS-5381RC/D can also be turn on via pressing the “Mic. On/Off” button if the Mic. active limit hasn’t been reached. These units must be turn off via pressing the “Mic. On/Off” button as well.

■ “Apply” (application software needed)

- ◇ If the Mic. request limit (set up by PC) has not been reached, pressing the “Mic. On/Off” button can request to speak;
- ◇ If the Mic. active limit (1/2/3/4) has been reached, all other requests cannot be approved. The VIP/chairman unit still can be activated when the total number of active microphone is less than 4 in the system.

A camera can focus an activated microphone automatically (application software needed).
Speaker’s video can be exported to and displayed on large screen(s).

3. Volume control

- a) The built-in loudspeaker of the delegate unit can be adjusted by the main unit speaker volume adjust knob;
- b) The earphone volume can be adjusted by the volume control button on the front or side of the delegate unit.

4. Charging

HCS-5381 conference unit can be charged with TES-ADP5V adapter, or be charged in HCS-5380CHG/06 charging unit. The charging indicator lights up for indication of the current power status and battery status when charging:

	Charging indicator
Charging	Flash
Full	On

After power on, the battery status will indicate via the battery indicator:

	Battery indicator
Charging	On
Full	Flash fast

6.5.2 The operation of chairman unit

The chairman unit features the functions of a delegate unit and in addition priority function:

- If the priority mode is set as "All mute" in the main unit configuration, all active conference units will be muted when the priority button on the chairman unit is pressed and return active when the priority button on the chairman unit is released;
- If the priority mode is set as "All off" in the main unit configuration, all active conference units will be turned off automatically when the priority button on the chairman unit is pressed.

Note:

☞ When there is more than one chairman unit in a system and if one chairman is pressing the priority key, the priority keys of the remaining chairman units will be inoperable temporarily.

Chapter 7 Web control software

Apply model: HCS-5300MA/80A, HCS-5300MB/80A, HCS-5300MC/80A; Running environment: browser for Firefox29.0, Google25.0, IE10 or higher.

7.1 Login and exit

The user inputs the IP address of the CMU into the Web browser to login. The default UserName is “admin” and the default password is “123456”, the password can be changed after login. The default username is administrators that cannot be deleted. The login interface is shown in the following figure:

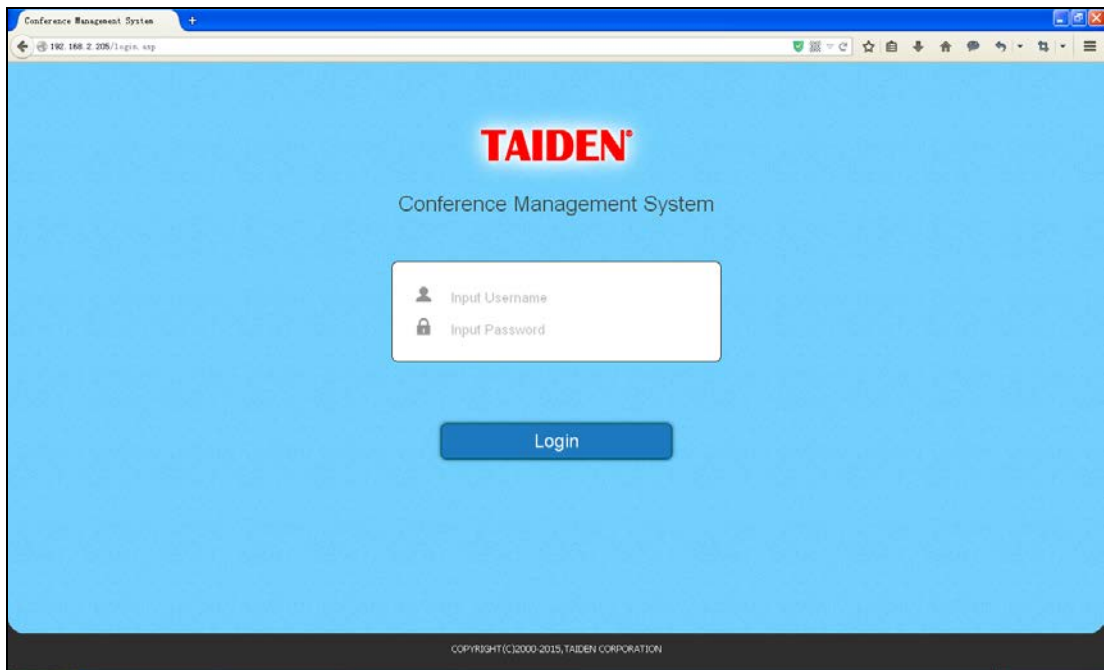
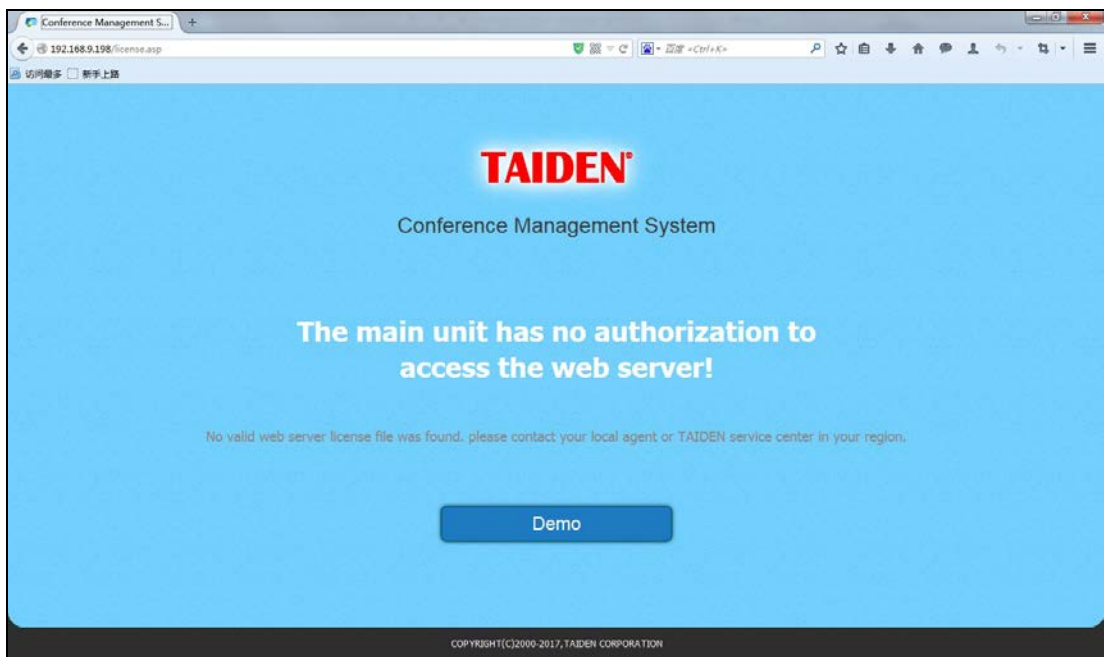

Figure 7.1 Login

Note:

Please make sure the main unit has the authorization to access the Web Server, or a note interface will be shown as the following figure, and you can press the “Demo” button to view the conference manage function of Web Server:



Input the UserName and password, then click the “Login” button and it will enter the conference management system interface automatically.

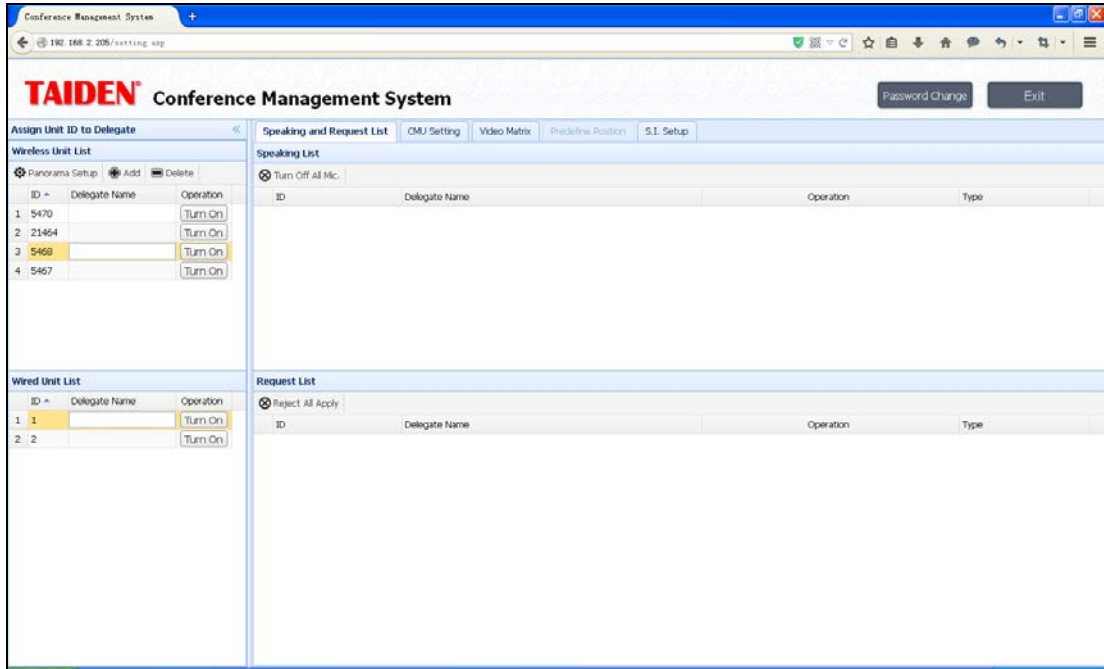

Figure 7.2 Conference Management System

There are two buttons in the right top of the interface:

- **Password Change:** click this button and the below dialog box is shown:

Password Change

Old Password:

New Password:

Password Confirm:

Input the Old Password, New Password and Password Confirm, and then click the “OK” button to change the password.

Note:

Password only supports a sequence of numbers or letters (case sensitive) with maximal 20 characters.

- **Exit:** exit the conference management system.

7.2 Conference management

7.2.1 Assign unit ID to delegate

It will list all ID of connective units in the system. User can assign them to delegates, open microphones, set up the camera predefined position, etc.. The interface is shown in the following figure:

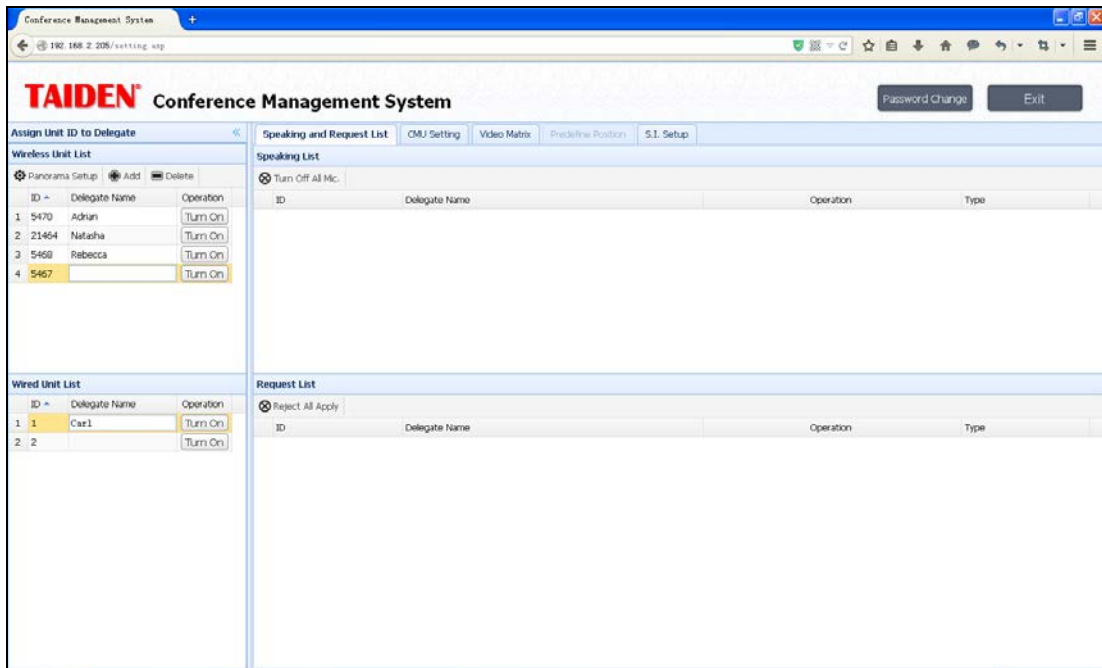
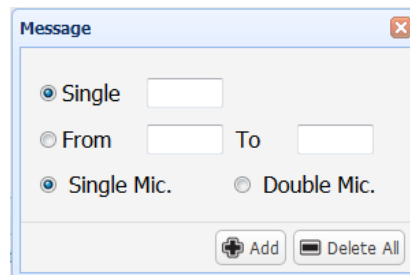

Figure 7.3 Assign Unit ID to Delegate

- **ID:** IDs of all microphones, can be listed in ascending or descending order by clicking the triangle icon;
- **Delegate Name:** double click and input a name (at most 128 characters) to assign the unit to the delegate;
- **Operation:** turn on the microphones:
“Turn On”: click this button to open the microphone;
- **Panorama Setup:** set up the Panorama (refer to [7.2.5](#));
- **Add:** wireless conference units must be added to the “Wireless Unit List” manually when being connected into the system first or after being deleted. Click this button and the below dialog box is shown:



Select “Single” or “From...To...”, then input the ID number and select the unit type (single mic. or double mic.), at last click the “Add” button. A maximum of 200 conference units can be added and their information will be displayed on the list automatically.

“Delete All”: delete all wireless units in the list.

Note:

Wired conference unit will be added into the list automatically once it is connected into the main unit.

- **Delete:** delete the selected wireless conference unit.

Note:

Wired conference unit will be deleted automatically when the “WiredMic Function Setting” in main unit menu is “No”.

7.2.2 Speaking and request list

Speaking and Request List displays the information of the active and requested microphones, includes Mic. ID, delegate name, camera control and unit type.

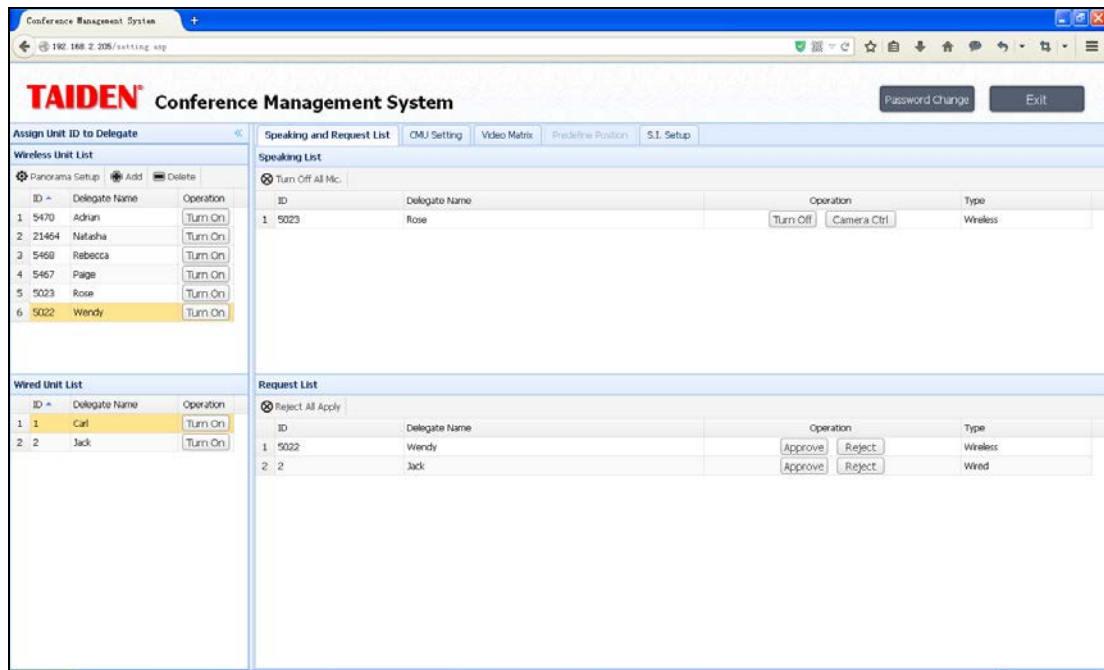

Figure 7.4 Speaking and Request List

- **Turn Off All Mic.:** turn off all the microphones on the speaking list;
- **Turn Off:** turn off the selected microphone;
- **Camera Ctrl:** click this button and set up the camera predefine position on the right side (refer to [7.2.5](#));
- **Type:** display the type of the conference unit, including wired conference unit and wireless conference unit;
- **Reject All Apply:** reject all the requests on the list;
- **Approve:** accept the selected unit's request, after clicking, the microphone is active and its information will be displayed on the speaking list;
- **Reject:** reject the selected unit's request.

7.2.3 CMU setting

CMU Setting includes Operation Mode, Active Microphones and Loudspeaker Volume. The CMU Setting interface as shown in the following figure:

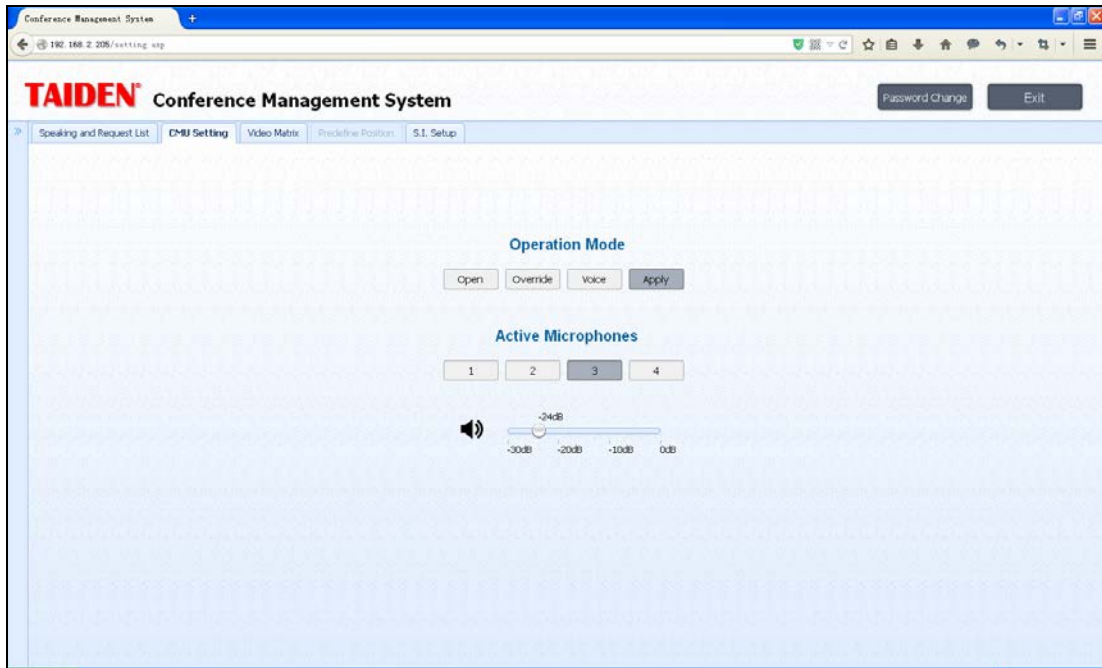

Figure 7.5 CMU Setting

- **Operation Mode:** set up the speaking mode, include Open/ Override/ Voice/ Apply;
 - ◆ **“Open”:** if the number of active microphones reaches the limit, the rest of the delegate microphones could not be activated; the chairman microphones still can be activated when the total number of active microphone is less than 4 in the system;
 - ◆ **“Override”:** if the number of active delegate microphone reaches the limit (1/2/3/4), turning on another delegate microphone will switch off the delegate microphone turned on first: delegates speak in FIFO mode. If the total number of active microphone is less than 4 in the system, the chairman microphones can be activated till the number reaches 4, turning on another chairman microphone will switch off the unit switched on first automatically (primarily switched off the delegate units and then the chairman units);
 - ◆ **“Voice”:** voice control mode, the microphone On/Off is controlled by voice: participator speaks towards the microphone and turns it on. In case of a speech pause, the microphone will turn off automatically. If the number of active microphones reaches the limit, the rest of the delegate microphones cannot be activated; the chairman microphones still can be activated when the total number of active microphone is less than 4 in the system;
 - ◆ **“Apply”:** apply mode, the delegate applies to speak and the chairman speaks directly by pressing the microphone ON/OFF key. The delegate can only speak when the operator approved his application. If the number of active microphones reaches the limit, all other requests cannot be approved. The chairman unit still can be activated if the total number of active microphone is less than 4 in the system.

- **Active Microphones:** the number of maximum active microphones (1/2/3/4 pcs);
- **Volume:** adjust the volume (-30 dB to 0 dB) of the loudspeakers.

7.2.4 Video matrix

It includes Video Matrix and Video Switch. The matrix, TMX-0804, is a high definition video matrix which includes one 8x4 video matrix.

7.2.4.1 Video Matrix

The setup of the Video Matrix interface is shown in the following figure:

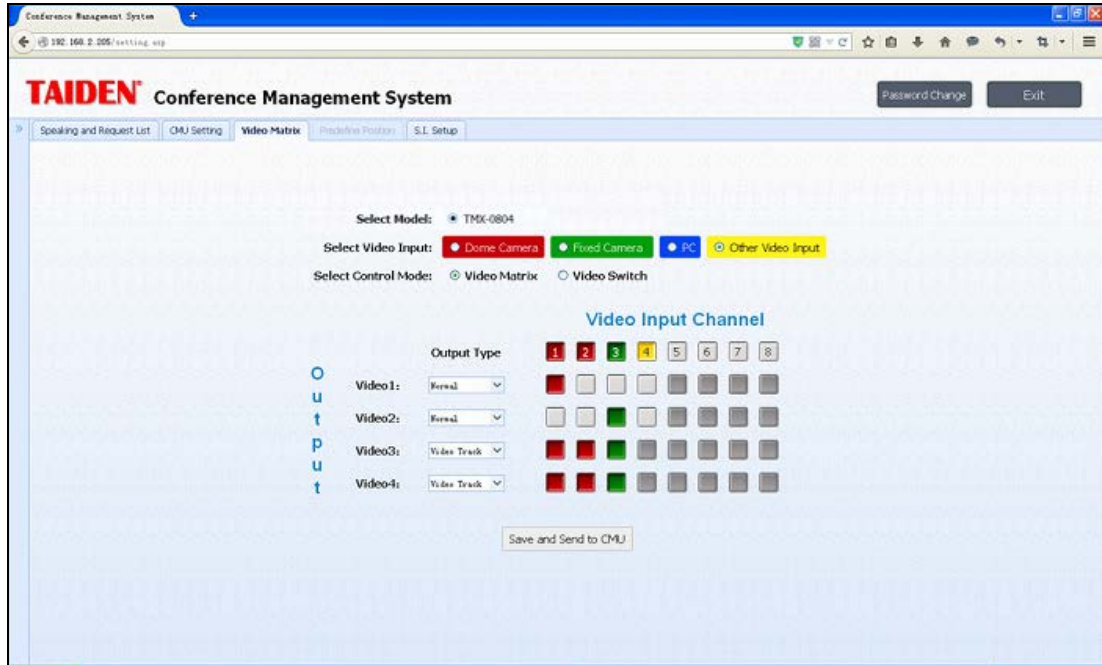

Figure 7.6 Video Matrix

- **Select Model:** system will select a model automatically according to the system connection, if selecting HCS-3316HD, the input and output cannot be set.
- **Select Video Input:** includes Dome Camera, Fixed Camera, PC and Other Video Input;
- **Output Type:** includes Normal and Video Track;
- **Save and send to CMU**

Matrix setup:

1. Assign video input type according to the actual situation;
2. Assign video output type;
3. Assign output channel for "normal" video output by clicking on the cross point of input and output;
4. Click "Save and Send to CMU" button to save current video matrix.

7.2.4.2 Video Switch

The interface of the Video Switch is shown in the following figure:

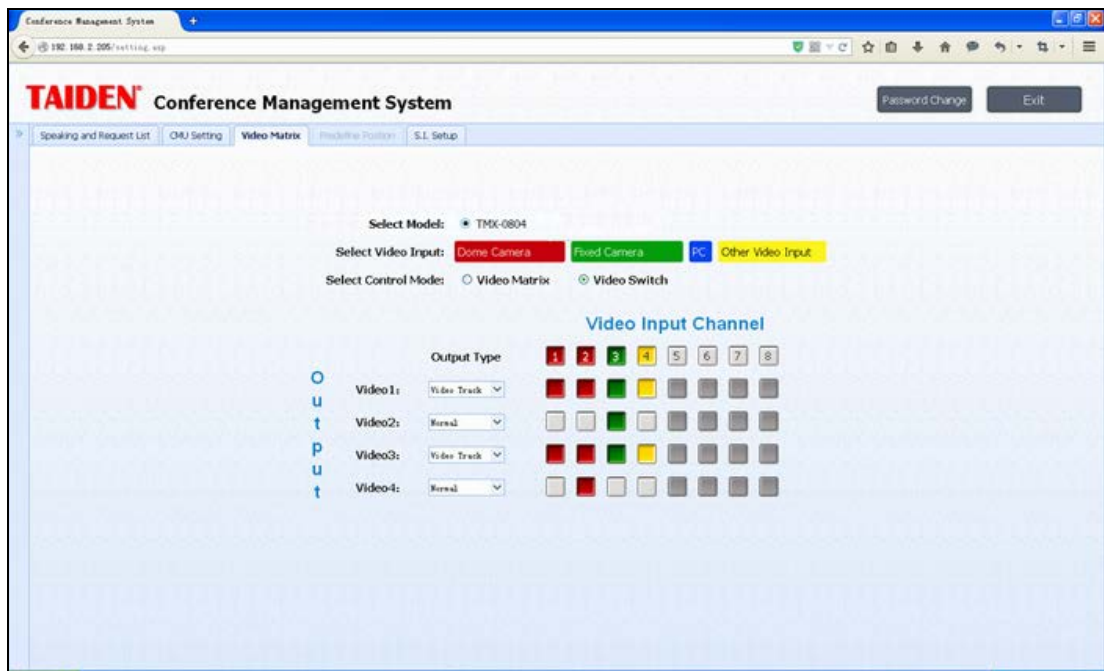

Figure 7.7 Video Switch

Matrix switch:

1. According to the setup of the video matrix, the video input type will be displayed automatically;
2. Assign corresponding output channel by clicking on the cross point of input and output;
3. Select "Video Track" under video 1-4 output line doublers, the selected output channel will be switched to the video track.

Note:

Video Switch is invalid for HCS-3316HD.

7.2.5 Predefined position

If the conference system is equipped with cameras, the system can carry out automatic video tracking, i.e. display the image of the speaking participator to the display devices (large screen, TV, and so on). Predefine position is to set the predefined position of each microphone.

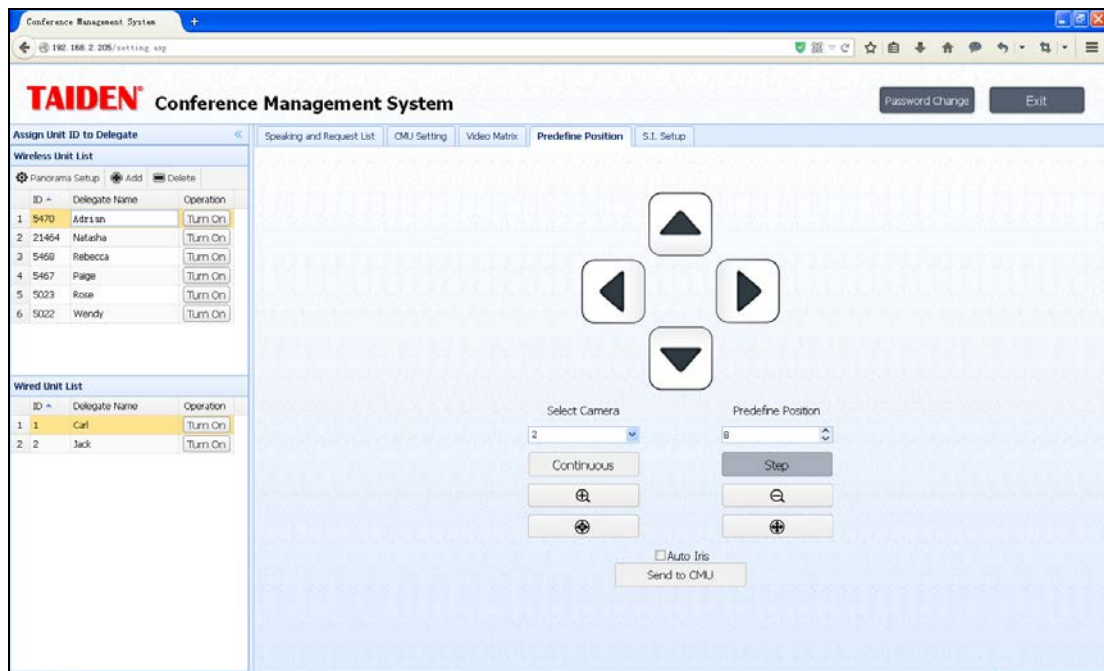

Figure 7.8 Predefine Position

■ Microphone predefined position setup:

1. Select a microphone on the speaking list, then click the “Camera Ctrl” button to open the “Predefine Position” interface;
2. Select the proper camera in the Select Camera combo box (since each conference can be equipped with multiple cameras, the operator shall select the proper camera to give the best image of each participator);
3. Select the predefined position number (each camera can accommodate 64 positions);
4. Adjust the camera angle by the four direction buttons, and click zoom in/out button to adjust the size of the video image;
5. Click the “Send to CMU” button to send the current predefined position to the CMU if the adjustment is done;
6. Repeat the above steps to set the predefined position for other seats/microphones;

During the conference, if all microphones are configured with predefined positions, the camera will aim at the speaking participator automatically (when video tracking setting in menu of main unit is “turn on”), i.e. automatic video tracking.

Note:

When connect to HCS-3316HD without matrix, please set the “Select Camera” to be 1;

If the camera features auto iris, you can select “Auto Iris” to be applied for all predefined positions. If “Auto Iris” option is checked, then all predefined positions will use auto iris; if not checked, the iris for each predefined position can be adjusted and saved respectively.

- ### ■ Panorama setup:
- select proper camera and predefined position number, then adjust the camera angle by the four direction buttons, and click zoom in/out button to adjust the size of the video image, at last, click the “Send to CMU” button to save the panorama if the adjustment is done.

7.2.6 S.I. setup

It includes channels, booths and language setting. The interface of S.I. setup is shown in the following figure:

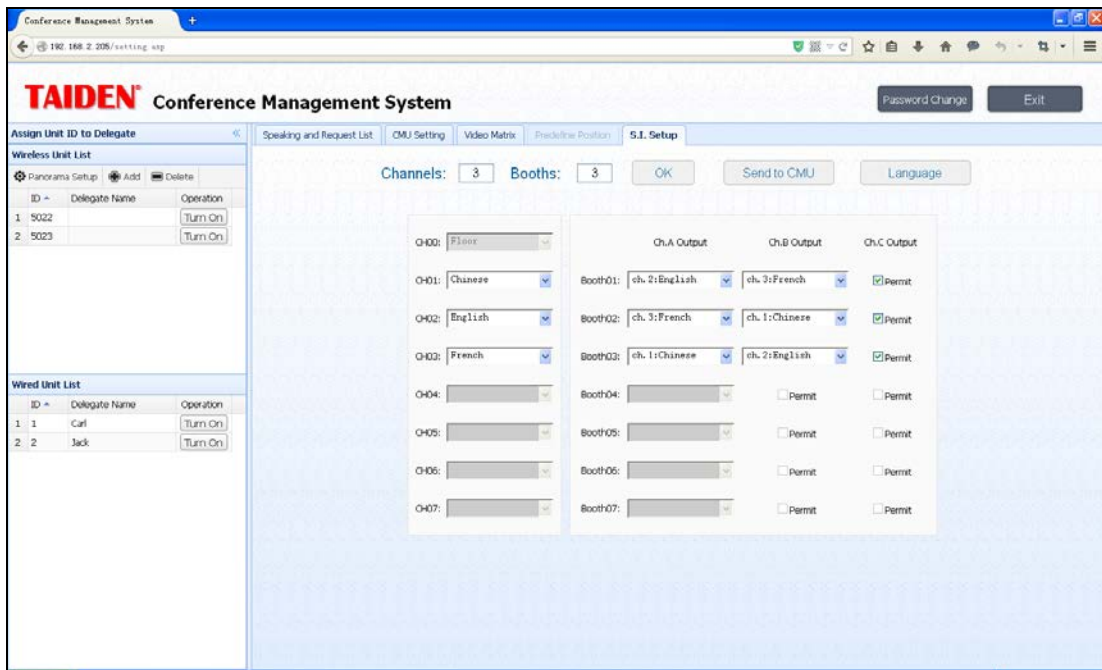

Figure 7.9 S.I. setup

- **Channels:** supports 7 S.I. channels at most. If there are wired conference units connected, the maximal number of channels is 3;

The system supports 7 S.I. channels, and distributes as well an output language for each channel. To set up the S.I. channels, the user should first select the number of channels, according to the conference requirement. If there are 3 different languages applied in the conference, the operator shall set the channel number to 3 and click the "OK" button to confirm. Assign now a specific language for each channel. After completion, click the "Send to CMU" button to save the settings and to update the conference main unit.

- **Booth:** supports 7 booths at most.

The system supports 7 Interpreter Booths. Each booth should set the outgoing A channel, and whether outgoing B and C channel is needed. If the outgoing C channel is checked, the outgoing language of B channel should be set. All settings shall be configured according to the actual conference requirements. When the setup is completed, click the "Send to CMU" button to save the settings and to update the conference main unit.

- **Language:** languages can be added or deleted conveniently, a maximum of 16 user-defined languages are supported. However, the languages listed by the system cannot be modified or deleted, as shown in the figure below:

Language ✖

Query: Abbreviation:

<input checked="" type="radio"/> Albanian	<input type="radio"/> Arabic	<input type="radio"/> Armenian	<input type="radio"/> Assamese	<input type="radio"/> Azerbaijani	<input type="radio"/> Balinese
<input type="radio"/> Bantu	<input type="radio"/> Basque	<input type="radio"/> Belarusian	<input type="radio"/> Bengali	<input type="radio"/> Brunei	<input type="radio"/> Bulgarian
<input type="radio"/> Burmese	<input type="radio"/> Cambodian	<input type="radio"/> Cantonese	<input type="radio"/> Catalan	<input type="radio"/> Chinese	<input type="radio"/> Corsican
<input type="radio"/> Croatian	<input type="radio"/> Czech	<input type="radio"/> Dai	<input type="radio"/> Danish	<input type="radio"/> Dari	<input type="radio"/> Dutch
<input type="radio"/> Dzongkha	<input type="radio"/> English	<input type="radio"/> Estonian	<input type="radio"/> Filipino	<input type="radio"/> Finnish	<input type="radio"/> Floor
<input type="radio"/> French	<input type="radio"/> Galician	<input type="radio"/> Georgian	<input type="radio"/> German	<input type="radio"/> Greek	<input type="radio"/> Gujarati
<input type="radio"/> Hawaiian	<input type="radio"/> Hebrew	<input type="radio"/> Hindi	<input type="radio"/> Hungarian	<input type="radio"/> Icelandic	<input type="radio"/> Indonesian
<input type="radio"/> Irish	<input type="radio"/> Italian	<input type="radio"/> Japanese	<input type="radio"/> Kannada	<input type="radio"/> Kashmiri	<input type="radio"/> Kazakh
<input type="radio"/> Kirghiz	<input type="radio"/> Korean	<input type="radio"/> Kurdish	<input type="radio"/> Lao	<input type="radio"/> Latvian	<input type="radio"/> Lithuanian
<input type="radio"/> Malay	<input type="radio"/> Malayalam	<input type="radio"/> Marathi	<input type="radio"/> Moldovan	<input type="radio"/> Mongolian	<input type="radio"/> Music
<input type="radio"/> Myanmar	<input type="radio"/> Ndebele	<input type="radio"/> Nepali	<input type="radio"/> Norwegian	<input type="radio"/> Oriya	<input type="radio"/> Panjabi
<input type="radio"/> Persian	<input type="radio"/> Polish	<input type="radio"/> Portuguese	<input type="radio"/> Romanian	<input type="radio"/> Romansh	<input type="radio"/> Russian
<input type="radio"/> Sanskrit	<input type="radio"/> Serbian	<input type="radio"/> Sindhi	<input type="radio"/> Singapore	<input type="radio"/> Sinhalese	<input type="radio"/> Slovak
<input type="radio"/> Slovenian	<input type="radio"/> Sotho	<input type="radio"/> Spanish	<input type="radio"/> Swahili	<input type="radio"/> Swedish	<input type="radio"/> Tajik
<input type="radio"/> Tamil	<input type="radio"/> Telugu	<input type="radio"/> Thai	<input type="radio"/> Tibetan	<input type="radio"/> Tswana	<input type="radio"/> Turkish
<input type="radio"/> Turkmen	<input type="radio"/> Uighur	<input type="radio"/> Ukrainian	<input type="radio"/> Unknown	<input type="radio"/> Urdu	<input type="radio"/> Vietnamese
<input type="radio"/> Welsh	<input type="radio"/> Zhuang	<input type="radio"/> Zulu			

Note:

The user-defined language only supports a sequence of numbers or letters (case sensitive) with a maximum of 8 characters, the abbreviation supports a maximum of 3 characters.

Chapter 8 Accessories

8.1 Digital IR conference room switcher

8.1.1 Functions and indications

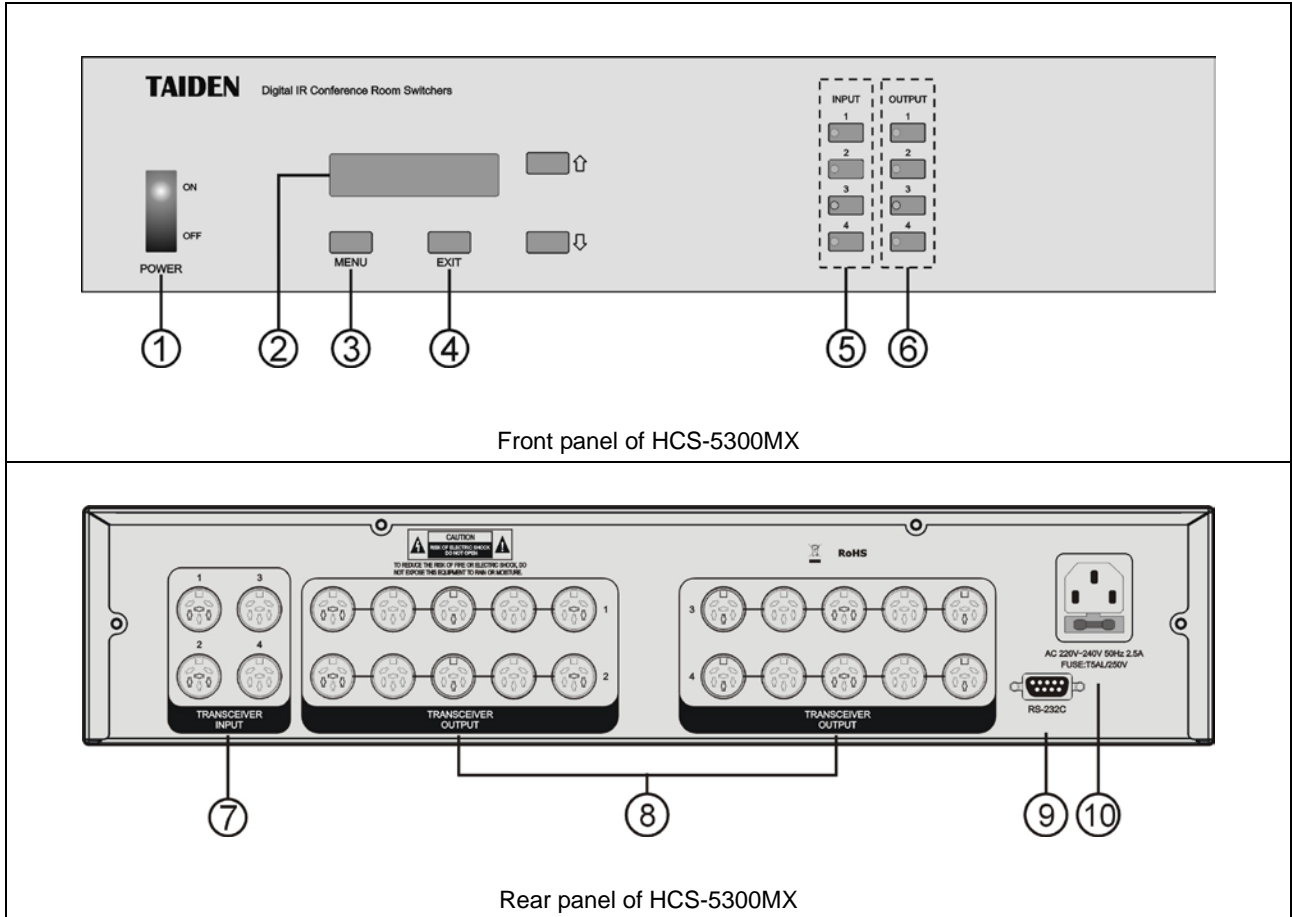

Figure 8.1 HCS-5300MX Digital IR Conference Room Switcher

- 1. Mains switch**
- 2. 16x2 segment LCD**
- 3. “MENU” button**
 - The LCD displays firmware version.
- 4. “EXIT” button**
 - The LCD displays the corresponding state of input channels and output groups
- 5. Input channel selectors with indicators (1-4)**
- 6. Output group selectors with indicators (1-4)**
- 7. Input channels (1-4)**
 - For connecting to HCS-5300M Digital IR Wireless Conference System Main Unit.
- 8. Output groups (1-4 group, 5 outputs per group)**
 - Up to 16 transceivers can be connected.
- 9. RS-232 port**
 - "COM" port is used for connecting to a central control system for central controlling.
- 10. Power supply**

8.1.2 Connection

8.1.2.1 Splitting/Combining several meeting rooms 1

Several meeting rooms can be split/ combined at leisure through the HCS-5300MX Digital IR Conference Room Switcher with CBL5300 cable. One HCS-5300MX can combine up to four meeting rooms.

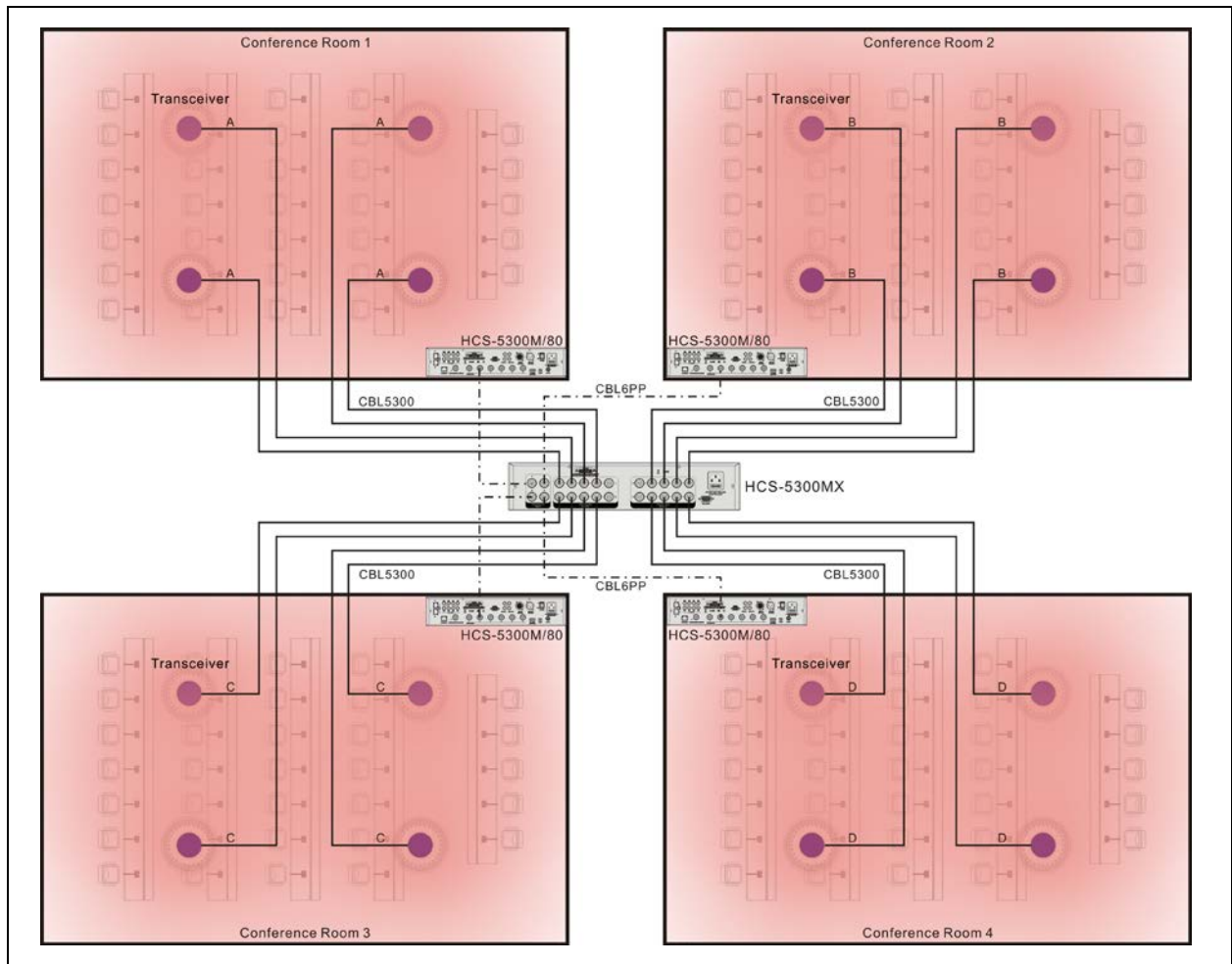

Figure 8.2 Splitting/Combining several meeting rooms 1

8.1.2.2 Splitting/Combining several meeting rooms 2

Several meeting rooms can be split/combined at leisure through the HCS-5300MX with CBL5300 cable to connect the transceivers and the HCS-8300MX with 6PIN to RJ45 cable to connect the interpreter units. Four

meeting rooms can be combined up at most to realize discussion, 1+7CHs simultaneous interpretation, central control, etc..

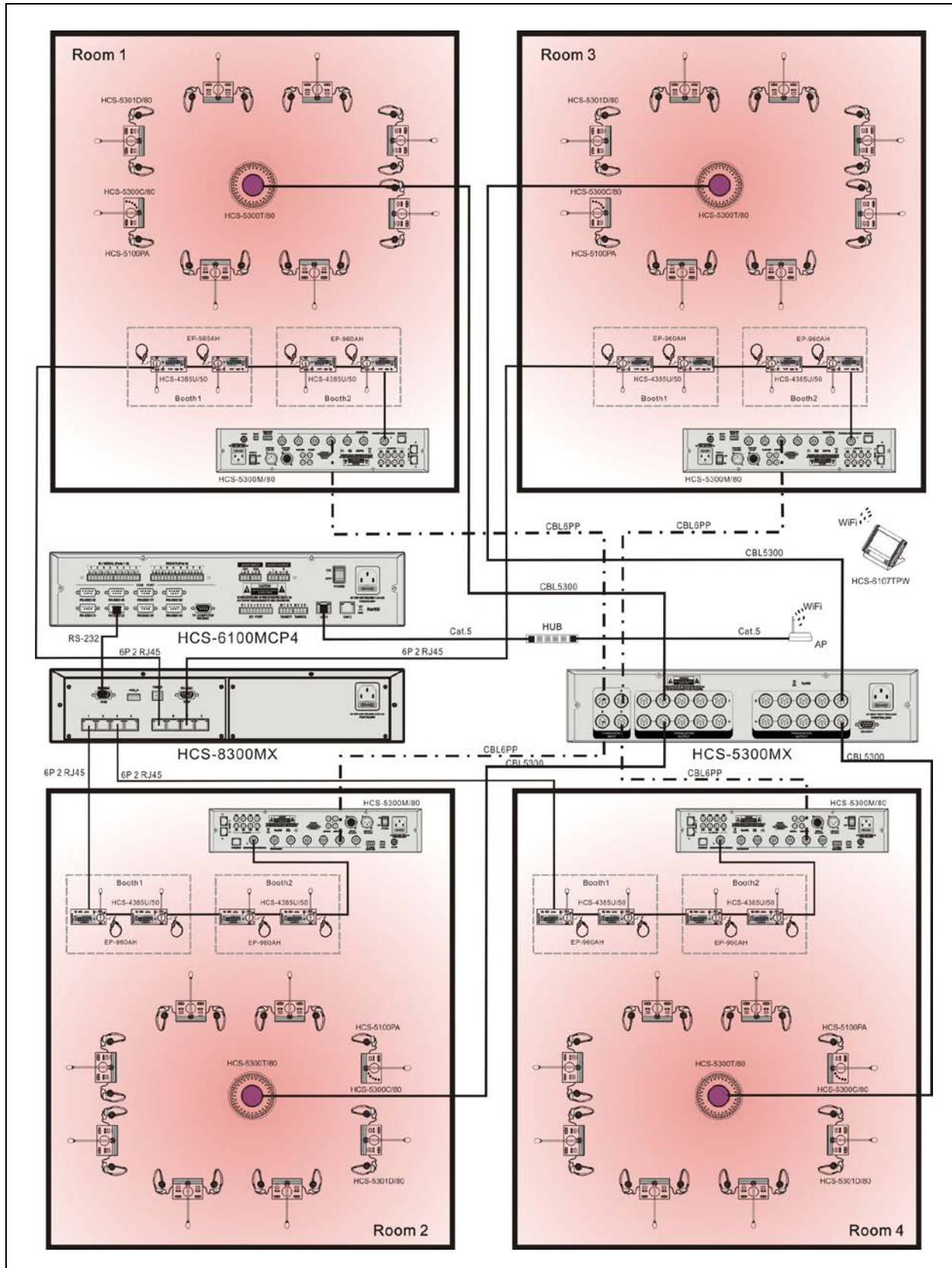

Figure 8.3 Splitting/Combining several meeting rooms

8.1.3 Configuration and operation

Switch on HCS-5300MX Digital IR Conference Room Switcher, it will start initialization:

```
Initializing.....  
Please wait
```

When the initialization is finished, the corresponding state of input channels and output groups will be displayed on the LCD:

```
Out: 1 2 3 4  
In: 1 2 3 4
```

Press the button at the front panel and go to the next operation:

- Press the “Menu” button to go to the main menu which includes “Enable Update” and “About”.

- “Enable Update”

```
Enable Update  
Disable
```

- a). Press the “ \uparrow/\downarrow ” button to switch to “Enable Update” and press “MENU” to turn to next step;
- b). Press the “ \uparrow/\downarrow ” button to select “Enable” or “Disable”;
- c). Press the “MENU” button to save and press “EXIT” to turn to the upper level menu.

- “About”

Press the “ \uparrow/\downarrow ” button to switch to “About” and press the “MENU” button, the firmware version of the switcher will be displayed on the LCD.

```
HCS-5300MX 1.02  
11:55:26 Dec 6
```

- Channel switch operation:

- Press the “INPUT 1...4” button to select the input channel, the corresponding indicator lights up;
- Press the “OUTPUT 1...4” button to select the output group(s), the corresponding indicator lights up, then the signal of the selected input channel will be switched to the selected output group(s). Press the selected “OUTPUT 1...4” button again to deselect the selected output group(s). If the input channel displays “X”, the output group is closed and the corresponding indicator is off.

8.2 Accessories

HCS-5300 can be power supplied by specific Lithium battery or power adapter.



Figure 8.4 HCS-5300BAT Lithium battery

■ Assemble procedure:

1. Assemble the battery into the slot on the bottom of the conference unit with the buckles on the right and left side of the battery aiming to the slot;
2. Push the battery into the slot tightly according to the arrow direction on the conference unit.

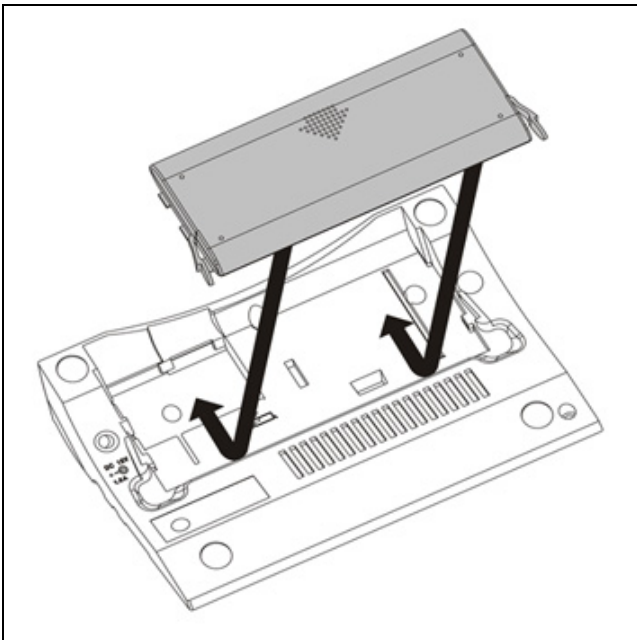

Figure 8.5 Assemble HCS-5300BAT battery

■ Disassemble procedure:

1. Press and hold the buckles on the right and left side of the battery;
2. Plug the battery out according to the arrow direction on the battery.

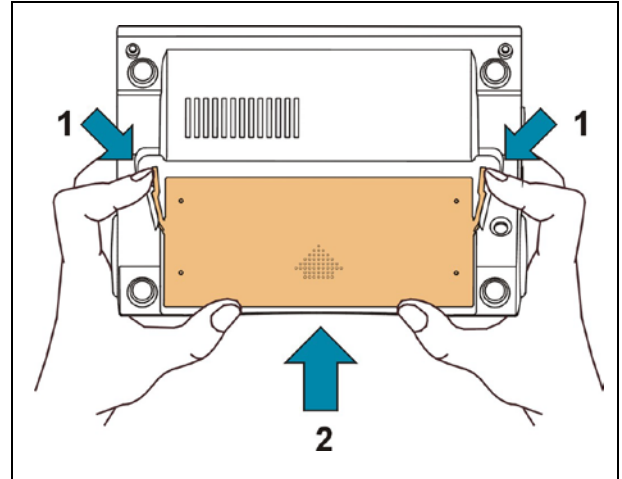

Figure 8.6 Disassemble HCS-5300BAT battery

8.3 Charging device

- HCS-5300CHG/08 charging unit

The charging unit can recharge up to 8 HCS-5300BAT batteries at one time by using universal power supply with automatic voltage matching. A charging indicator and a fully charged indicator on the charging unit are displaying the battery status. The charging circuit will check if the battery is connected and control the charging process.

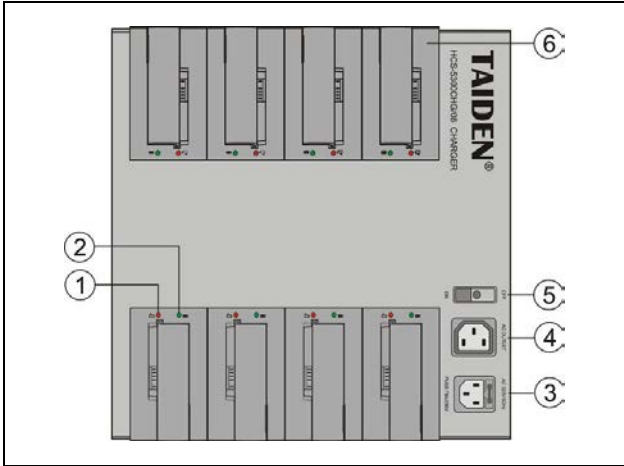

Figure 8.7 HCS-5300CHG/08 charging unit

Figure 8.7:

1. Charging indicating light
2. Fully charged indicating light
3. Power input
4. Power output
5. Power switch
6. Charging lattice - can charge up to 8 HCS-5300BAT batteries at one time

Charging procedure:

1. Connect power core;
2. Switch on;
3. Insert batteries;
4. Battery charging indicator lights up:

LED Status	Charging Status
Green	Fully charged or battery not inserted
Red	Charging
LED off	Charging unit power off

Note:

The charging unit is only used to charge HCS-5300BAT. Neither charge other battery types with HCS-5300CHG/08 nor charge HCS-5300BAT with other charging unit.

- HCS-5300CHG/06 charging unit

The charging unit can recharge up to 6 HCS-5380/5381 series conference units at one time by using 9 VDC, 6 A power adapter.



Figure 8.8 HCS-5300CHG/06 charging unit

- HCS-5300CHG/06A charging unit

The charging unit can recharge up to 6 HCS-5380 series conference units at one time by using 9 VDC, 6 A power adapter.

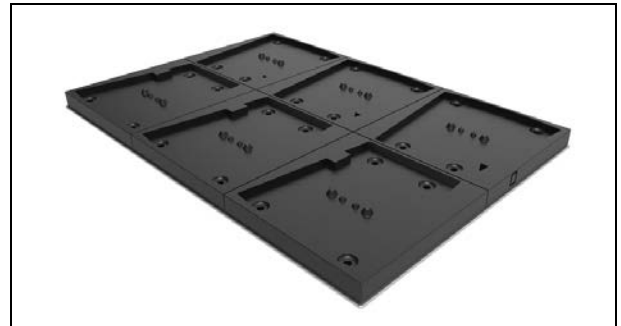

Figure 8.9 HCS-5300CHG/06A charging unit

8.4 Dedicated extension cable for digital infrared transceiver

CBL5300 dedicated cable is used to connect the digital infrared transceiver and the digital infrared wireless conference main unit. It features one male 6P-DIN connector at one end and one female 6P-DIN connector at the opposite end. Available lengths: 5, 10, 20, 30, 40 or 50 meters.



Figure 8.10 CBL5300 dedicated extension cable for digital infrared transceiver

8.5 Power adapter

- HCS-ADP15V power adapter

Connect the HCS-ADP15V to the power adapter interface at the bottom of the HCS-5300/80 series new generation digital infrared wireless conference unit.



Figure 8.11 HCS-ADP15V power adapter

- HCS-ADP24V power adapter

Connect the HCS-ADP24V to the power adapter interface at the top of the 5300TH/80 digital infrared transceiver.



Figure 8.12 HCS-ADP24V power adapter

- HCS-ADP24V2 power adapter

Connect the HCS-ADP24V2 to the power adapter interface at the bottom of the HCS-5300TWN/80 digital infrared transceiver.



Figure 8.13 HCS-ADP24V2 power adapter

- TES-ADP5V power adapter

Connect the TES-ADP5V to the power adapter interface of the HCS-5380 digital infrared wireless conference unit.



Figure 8.14 TES-ADP5V power adapter

8.6 HCS-5300TZJ2 transceiver stand



Figure 8.15 HCS-5300TZJ2

HCS-5300TZJ2 transceiver stand is used to mount the HCS-5300TD/80, its height can be adjusted from 1.1 m to 2.7 m. For the installation method, refer to section [3.5](#).

8.7 Earphones

The earphones are connected to the conference units via an Ø 3.5 mm stereo jack. Suitable earphone types include:

- EP-820AS single earphone



- EP-829 single earphone



- EP-830 single earphone



- HCS-5100PA headphone



- EP-960BH headphone



- Any other compatible type (see chapter [10](#) Technical Data).

Chapter 9 Fault diagnosis

Some simple trouble-shooting instructions are provided in this chapter. If more serious faults arise, please contact a qualified technician.

9.1 Digital infrared wireless conference unit

Fault	Analysis	Solution
Cannot startup.	The battery is not charged (When using the lithium-ion battery)	The battery is not charged when leaving the factory, please fully charge the battery before using.
	No power supply (when using the power adapter).	Please connect the power supply correctly and check the DC socket.
No audio output from the speaker or earphone.	Improper volume control.	Adjust the volume to proper position.
	The earphone is not plugged-in completely	Insert the earphone completely.
Cannot speak.	Transceiver working indicating light is off or not.	Check the I/O cable connecting the transceiver with the main unit.
Cannot operate MIC. ON/OFF button.	Infrared transceiver is directly under sunshine or spotlight.	Reposition it and avoid direct sunshine or spotlight.
	Is there any obstacle between the transceiver and the conference unit? Is the transceiver type suitable for the height and are all conference units in the coverage area? (If the power indicating light and Mic. active light blink at the same time, it stands for the conference unit is out of coverage area)	Select suitable transceiver type according to height and mount them in that way not to block the direct view.
	The cable between the transceiver and the main unit is not connected.	Connect the cable.
	In priority mode.	Please operate this button when priority mode is finished.
Battery working time is short.	Not fully charged.	Charging for 6 hours can fully charge the battery.
	Out of battery service life (HCS-5300/80 series).	Use new batteries (complete set). Note: every new battery can be charged about 300 times.
	Poor transceiver planning	Please contact the local TAIDEN service center.

9.2 Digital infrared wireless main unit

Fault	Analysis	Solution
Cannot startup.	No power supply or no power cord connected to main unit.	Connect the power supply with the power cord.

9.3 Charging Unit

Fault	Analysis	Solution
The power indicating light is not on when the unit is powered on.	The power cord is not plugged into the power socket.	Plug the power cord into the power socket and supply power to the charging unit.
	The fuse has blown.	Change the fuse. Please contact the local TAIDEN service center.
The charging indicating light of the charging lattice is not lighting up though the battery is plugged-in.	The battery is not properly plugged-in.	Plug-in the battery properly into the charging lattice.
	The charging contact is covered by dust.	Please clean the charging contact with dry cotton swab.
Battery working time is short.	Lithium-Ion battery deteriorated.	Please replace with new HCS-5300BAT Lithium-Ion battery.

Chapter 10 Technical data

10.1 System specification

System performance

Conforms to the international standard ISO 22259
The carrier frequency (0~3) transmitted by the main unit conforms to IEC 61603-7, the international standard for digital infra-red transmission of audio signals for conference and similar applications.

Transmission characteristics

IR transmission wavelength: 870 nm

Modulation frequency:

1 to 8 MHz, carrier frequency (0~3) transmitted by main unit according to IEC 61603-7

Protocol and modulation:

DQPSK, carrier frequency (0~3) transmitted by main unit according to IEC 61603-7

Cabling and system limits

Transceiver cable type:

Specific 6PIN cable (HCS-5352 is optional)

Maximum number of transceivers:

4 per output, 10 in total (HCS-5300MA/MB/80A)

4 per output, 6 in total (HCS-5300MC/80A)

Maximum number of interpreter units:

14 in total (HCS-5300MA/MB/80A)

Maximum cable length: 60 m per output

System environmental conditions

Working conditions fixed/stationary/portable

Temperature range:

- Transport: -40 °C to +70 °C

- Operating: 0 °C to +45 °C

Max. Relative humidity: < 95% (not condensing)

Safety: Compliant with EN 60065

EMC emission: Compliant with EN 55022

EMC immunity: Compliant with EN 55024

Approvals: CE, FCC

Power harmonics: Compliant with EN 61000-3-2

Voltage fluctuations and flicker: Compliant with EN 61000-3-3

10.2 Digital infrared wireless main unit of HCS-5300M/80

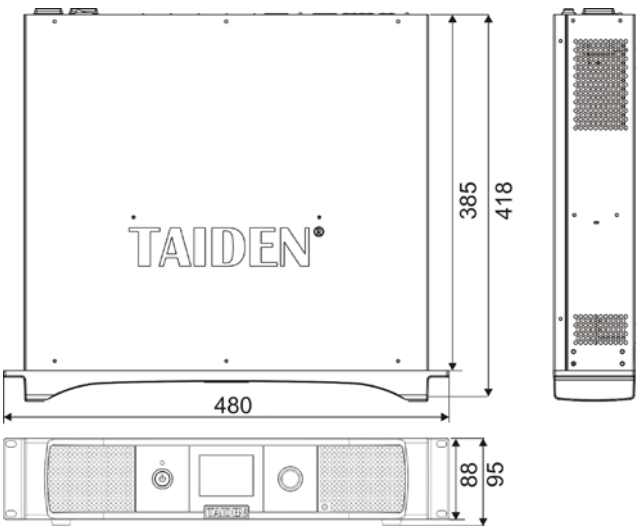
Type	HCS-5300MA/80A	HCS-5300MB/80A	HCS-5300MC/80A
Discussion	✓	✓	✓
Simultaneous interpretation	Max. (1+7) channels	Max. (1+7) channels	-
Vote	✓	-	-
Dante	✓	-	-
Mains voltage	AC 100 V-120 V 60 Hz or AC 220 V-240 V 50 Hz		
Power consumption	Max. 160 W		
Audio inputs	LINE IN 1: +10 dBu, balanced, XLR socket LINE IN 2: +15 dBu, unbalanced, RCA jack		
Audio outputs	LINE OUT 1: +20 dBu, balanced, XLR socket LINE OUT 2: +20 dBu, unbalanced, RCA jack SI. INPUT (CH 0-7): +10 dBu, unbalanced, RCA jack		
Maximal number of conference units	≤1000 units		
Transceivers I/O terminal	6P-DIN sockets x 6		
External control terminal	RS-232C D-sub (9 P, female), USB interface, RJ45 (ETHERNET, Dante)		
Display	256x32 LCD		
Interpreter's unit terminal	1 6P-DIN socket		
HF OUT (Radiator terminal)	1 BNC connector		
Alarm terminal	3.81 mm Phoenix connectors, 2 pole		
Video switcher terminal	3.81 mm Phoenix connectors, 4 pole		
Weighted signal-to-noise ratio	≥90 dBA		
Dynamic range	≥90 dB		
Audio frequency response	80-20000 Hz (-3 dB)		
Total harmonic distortion at 1 kHz	≤0.05 %		
Crosstalk attenuation at 1 kHz	≥80 dB		
Dimensions			
Weight	11.8 kg	11.8 kg	9.3 kg
Color	Dark grey		

10.3 Digital infrared transceiver

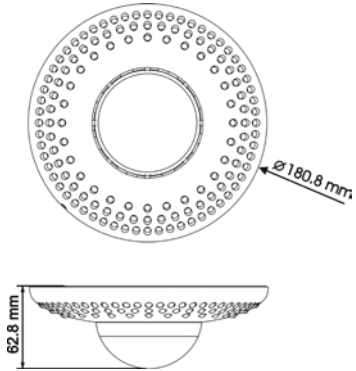
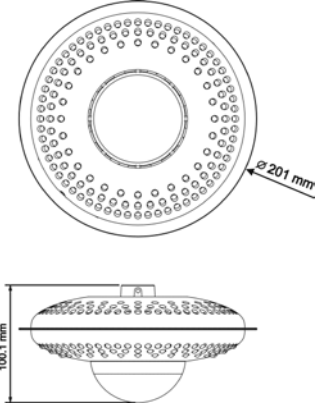
Type		HCS-5300TD/80	HCS-5300TDS/80
Voltage		33 V DC (supplied from HCS-5300)	
Current consumption		Max. 550 mA	
Mounting		Tripod, wall or ceiling mounted	Suspension
Infrared emitter/detector	Wavelength	870 nm	
	Modulation method	DQPSK	
	Carrier frequency	1 ~ 8 MHz	
	Communication area	Area radius from the point underneath the unit Approx. 13 m in radius (ceiling height: 2.5 - 3 m) Approx. 11 m in radius (ceiling height: 3.5 – 4.5 m) Approx. 9 m in radius (ceiling height: 5 - 7 m)	
Connection terminal		6P-DIN	
Cable		2 m specific cable with 6P-DIN male plug	
Dimensions			
Weight		0.5 kg	0.6 kg
Color		Silver/Charcoal gray/White	

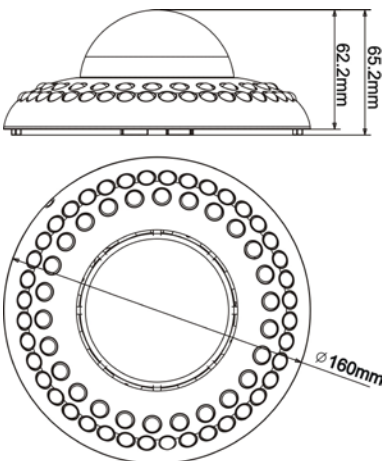
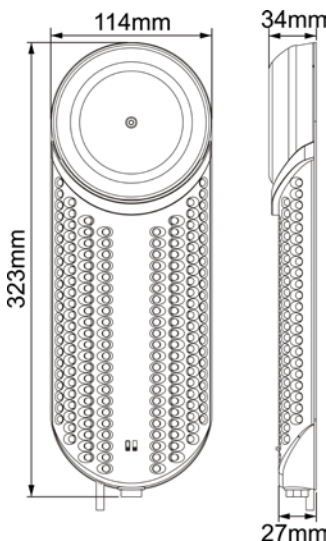
Type	HCS-5300TH/80	HCS-5300TWN/80
Voltage	33 V DC (supplied from HCS-5300M) 24 V DC (supplied from HCS-ADP24V)	33 V DC (supplied from HCS-5300M) 24 V DC (supplied from HCS-ADP24V2)
Current consumption	Max. 550 mA	Max. 650 mA (supplied from HCS-5300M) Max. 650 mA (supplied from adapter)
Mounting	Tripod, wall or ceiling mounted	
Infrared emitter/detector	Wavelength	870 nm
	Modulation method	DQPSK
	Carrier frequency	1 ~ 8 MHz
	Communication area	Area radius from the point underneath the unit Approx. 9 m in radius (ceiling height: 6 m) Approx. 11 m in radius (ceiling height: 9 m) Approx. 9 m in radius (ceiling height: 12 m)
Connection terminal	6P-DIN, DC power adapter interface	6P-DIN, power adapter interface 2P aviation plug
Cable	2 m specific cable with 6P-DIN male plug	
Dimensions		
Weight	0.6 kg	0.9 kg
Color	Silver/Charcoal gray/White	Black

10.4 HCS-5300/80 Series digital infrared wireless conference unit

Type	HCS-5300CE/80	HCS-5300DE/80	HCS-5301D/80	HCS-5302D/80	HCS-5302C/80
Discussion	√	√	√	√	√
Voting	5 keys		-	-	-
Simultaneous interpretation	1+7 channels	1+7channels	2x (1+7) channels	-	-
Priority key	√	-	-	-	√
Voltage	11.1 V DC (HCS-5300BAT battery); 15 V DC (HCS-ADP15V power adapter)				
Current consumption	When Mic on: 320 mA When Mic off: 65 mA				
Infrared emitter/receiver	Wavelength	870 nm (AM: Brightness modulation)			
	Modulation method	DQPSK			
	Carrier frequency	Transmission: Control channel: 3.8 MHz Audio channel 1: 4.3 MHz Audio channel 2: 4.8 MHz Audio channel 3: 5.8 MHz Audio channel 4: 6.3 MHz Reception: Floor audio + interpretation audio (0-3) + Control signal: 2.333 MHz Floor audio + interpretation audio (4-7) + Control signal: 1.666 MHz			
	Acceptance/emission angle	Vertical: angle selectable, range: 125°; Horizontal: 120°			
Output	Built-in louderspeaker: 4 Ω, 1 W Earphone: Ø 3.5 mm				
Display	64x48 LCD display				
Operation time of battery	When Mic on: approx. 14.4hours When Mic off: approx. 48 hours				
Charging time of battery	Approx. 6 hours via HCS-5300CHG/08 Approx. 4 hours via HCS-ADP15V				
SNR	≥ 90 dB(A)				
Frequency response	80-20000 Hz (-3 dB)				
Dynamic range	≥ 90 dB				
Total harmonic distortion at 1 kHz	≤ 0.05 %				
Crosstalk attenuation at 1 kHz	≥ 80 dB				
Microphone input impedance	680 Ω				
Earphone load	≥ 16 Ω x 2				
Earphone volume	10 mW				
Mic. gain adjustable range	-12 dB - +12 dB				
Mic. treble/bass adjustable range	-12 dB - +12 dB				

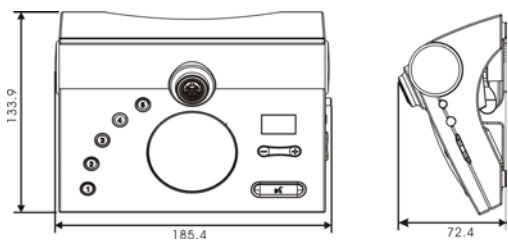
Type	HCS-5300CE/80	HCS-5300DE/80	HCS-5301D/80	HCS-5302D/80	HCS-5302C/80
Dimensions					
Weight (excl. battery)	0.5 kg				
Weight (incl. battery)	0.8 kg				
Color	Silver/ Charcoal gray				
Microphone	Type	Uni-directional electret condenser microphone			
	Sensitivity	-46 dBV/Pa			
	Frequency response	30-20000 Hz			
	Directivity 0°/180°	≥ 20 dB (1kHz)			
	Equivalent noise	20 dBA (SPL)			
	Maximum sound pressure level	125 dB (THD≤3%)			
	Standard stem microphone	MS33EGB1B/S			

10.5 HCS-5380 Series digital infrared wireless conference unit

Type		HCS-5380C series	HCS-5380D series
Voltage		Built-in 3.7 V/5200 mAh recharge battery; 5 V, 2 A (TES-ADP5V power adapter)	
Infrared emitter/receiver	Wavelength	870 nm (AM: Brightness modulation)	
	Modulation method	DQPSK	
	Carrier frequency	Transmission: Control channel: 3.8 MHz Audio channel 1: 4.3 MHz Audio channel 2: 4.8 MHz Audio channel 3: 5.8 MHz Audio channel 4: 6.3 MHz Reception: Floor audio + interpretation audio (0-3) + Control signal: 2.333 MHz Floor audio + interpretation audio (4-7) + Control signal: 1.666 MHz	
	Acceptance/emission angle	Vertical: angle selectable, range: 125°; Horizontal: 120°	
Output		Built-in louderspeaker: 4 Ω, 1 W; Earphone: Ø 3.5 mm	
Display		128x36 OLED display	
Operation time of battery (IR signal is sufficient)		When Mic on: approx. 12 hours; When Mic off: approx. 40 hours	
Charging time of battery		Approx. 4 hours	
SNR		≥ 90 dB(A)	
Frequency response		80-20000 Hz (-3 dB)	
Dynamic range		≥ 90 dB	
Total harmonic distortion at 1 kHz		≤ 0.05 %	
Crosstalk attenuation at 1 kHz		≥ 80 dB	
Microphone input impedance		680 Ω	
Earphone load		≥ 16 Ω x 2	
Earphone volume		10 mW	
Mic. gain adjustable range		-12 dB - +12 dB	
Mic. treble/bass adjustable range		-12 dB - +12 dB	
Dimensions			
Weight		0.9 kg (w/o. stem)	
Color		Champagne/ Charcoal gray	
Microphone	Type	Uni-directional electret condenser microphone	
	Sensitivity	-46 dBV/Pa	
	Frequency response	30-20000 Hz	
	Directivity 0°/180°	≥ 20 dB (1kHz)	
	Equivalent noise	20 dBA (SPL)	
	Maximum sound pressure level	125 dB (THD≤3%)	
	Standard stem microphone	MS33EGB1B/S	

10.6 HCS-5381 Series digital infrared wireless conference unit

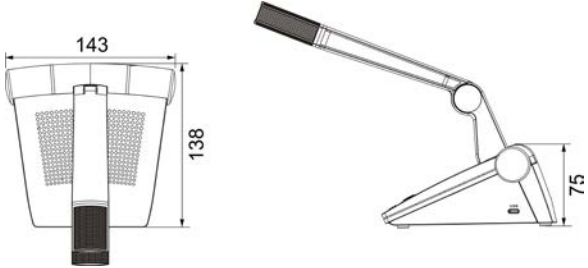
Type		HCS-5381RC series	HCS-5381RD series
Voltage		Built-in 3.7 V/5200 mAh recharge battery; 5 V, 2 A (TES-ADP5V power adapter)	
Infrared emitter/receiver	Wavelength	870 nm (AM: Brightness modulation)	
	Modulation method	DQPSK	
	Carrier frequency	Transmission: Control channel: 3.8 MHz Audio channel 1: 4.3 MHz Audio channel 2: 4.8 MHz Audio channel 3: 5.8 MHz Audio channel 4: 6.3 MHz Reception: Floor audio + interpretation audio (0-3) + Control signal: 2.333 MHz Floor audio + interpretation audio (4-7) + Control signal: 1.666 MHz	
	Acceptance/emission angle	Vertical: angle selectable, range: 125°; Horizontal: 120°	
Output		Built-in loudspeaker: 4 Ω, 1 W; Earphone: Ø 3.5 mm	
Operation time of battery (IR signal is sufficient)		When Mic on: approx. 12 hours; When Mic off: approx. 40 hours	
Charging time of battery		Approx. 4 hours	
SNR		≥ 90 dB(A)	
Frequency response		80-20000 Hz (-3 dB)	
Dynamic range		≥ 90 dB	
Total harmonic distortion at 1 kHz		≤ 0.05 %	
Microphone input impedance		680 Ω	
Earphone load		≥ 16 Ω x 2	
Earphone volume		10 mW	
Mic. gain adjustable range		-12 dB - +12 dB	
Mic. treble/bass adjustable range		-15 dB - +15 dB	
Dimensions			
Weight		1.2 kg	
Color		Charcoal gray	
Microphone	Type	Uni-directional electret condenser microphone	
	Sensitivity	-38 dBV/Pa	
	Frequency response	50-20000 Hz	
	Directivity	≥ 15 dB (1kHz) (0°/180°) ≥ 20 dB (1kHz) (0°/1350°)	
	Equivalent noise	20 dBA (SPL)	
	Maximum sound pressure level	139 dB (THD≤3%)	

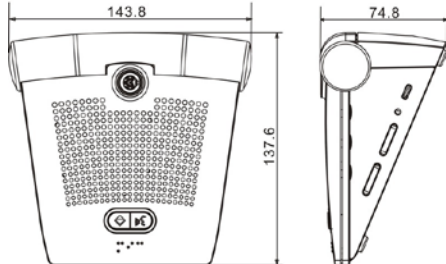
Type		HCS-5381C series	HCS-5381D series
Voltage		Built-in 3.7 V/5200 mAh recharge battery; 5 V, 2 A (TES-ADP5V power adapter)	
Infrared emitter/receiver	Wavelength	870 nm (AM: Brightness modulation)	
	Modulation method	DQPSK	
	Carrier frequency	Transmission: Control channel: 3.8 MHz Audio channel 1: 4.3 MHz Audio channel 2: 4.8 MHz Audio channel 3: 5.8 MHz Audio channel 4: 6.3 MHz Reception: Floor audio + interpretation audio (0-3) + Control signal: 2.333 MHz Floor audio + interpretation audio (4-7) + Control signal: 1.666 MHz	
	Acceptance/emission angle	Vertical: angle selectable, range: 125°; Horizontal: 120°	
Output		Built-in loudspeaker: 4 Ω, 1 W; Earphone: Ø 3.5 mm	
Operation time of battery (IR signal is sufficient)		When Mic on: approx. 12 hours; When Mic off: approx. 40 hours	
Charging time of battery		Approx. 4 hours	
SNR		≥ 90 dB(A)	
Frequency response		80-20000 Hz (-3 dB)	
Dynamic range		≥ 90 dB	
Total harmonic distortion at 1 kHz		≤ 0.05 %	
Microphone input impedance		680 Ω	
Earphone load		≥ 16 Ω x 2	
Earphone volume		10 mW	
Mic. gain adjustable range		-12 dB - +12 dB	
Mic. treble/bass adjustable range		-15 dB - +15 dB	
Dimensions			
Weight		0.9 kg (w/o. stem)	
Color		Champagne/Charcoal gray	
Microphone	Type	Uni-directional electret condenser microphone	
	Sensitivity	-46 dBV/Pa	
	Frequency response	30-20000 Hz	
	Directivity	≥ 20 dB (1kHz) (0°/180°)	
	Equivalent noise	20 dBA (SPL)	
	Maximum sound pressure level	125 dB (THD≤3%)	
	Standard stem microphone	MS33EGB1B/S	

10.7 Digital IR Conference Room Switcher

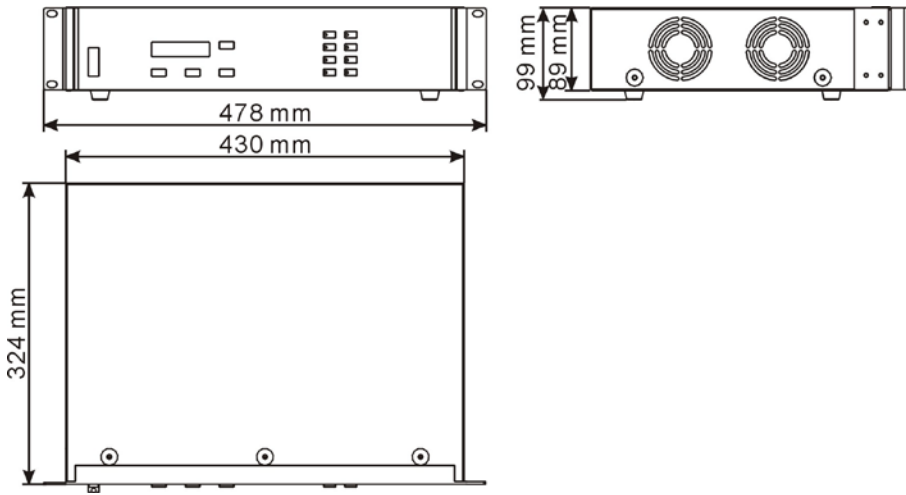
Type	HCS-5300MX
Mains voltage	AC 100 V - 120 V 60 Hz or AC 220 V - 240 V 50 Hz
Power consumption	15 W
Input interfaces	4 6P-DIN sockets
Output interfaces	20 6P-DIN sockets in 4 groups, 5 sockets per group
Dimensions	 <p>The drawing shows three views of the HCS-5300MX switcher. The front view shows a width of 478 mm and a depth of 430 mm. The top view shows a width of 430 mm and a depth of 324 mm. The side view shows a height of 99 mm. The device features two cooling fans on the top surface and four 6P-DIN input sockets on the front panel.</p>
Weight	10.6 kg
Color	White

10.8 Lithium battery

Type	HCS-5300BAT
Nominal voltage	11.1 V DC
Nominal capacity	4400 mAh
Dimensions	140 (w) x 28 (h) x 58 (d) mm
Weight	0.3 kg
Color	Black

10.9 Charging Device

Type	HCS-5300CHG/08	HCS-5300CHG/06 HCS-5300CHG/06A
Mains voltage	AC 100 V - 240 V 50/60 Hz	9 V, 6 A adapter
Power consumption	Max. 380 W	Max. 50 W
Charging Time	Approx. 6 hours	Approx. 4 hours
Charging Capacity	8 HCS-5300BAT batteries	6 HCS-5380/5381 series units (HCS-5300CHG/06) 6 HCS-5380 series units (HCS-5300CHG/06A)
LED indicator	Power indicator, charging status	--
Dimensions		
Weight	4.5 kg	0.4 kg
Color	White	Black

10.10 Power adapter

Type	HCS-ADP15V	HCS-ADP24V HCS-ADP24V2	TES-ADP5V
Mains voltage	AC 100-240 V 50 Hz/60 Hz		
Output	15 V DC, 2.4 A	24 V DC, 1.5 A	5 V, 2 A
Cable Length	3 m		1 m
Dimensions (mm)	95 x 28 x 45		39 x 27 x 43
Weight	0.3 kg		50 g
Color	Black		White

10.11 Distributor

Type	HCS-5352
Voltage	33 V DC (supplied from HCS-5300M)
Number of I/O terminals	1 In / 4 Out
Connector	4 x 6P-DIN socket + 2.1 m cable with 6P-DIN plug
Dimensions (mm)	149 x 35 x 90
Weight	0.3 kg
Color	Charcoal gray

10.12 CBL-5300 Dedicated extension cable

- HCS-5300TD/TDS/80 dedicated extension cable
- With one male 6P-DIN connector at one end and one female 6P-DIN connector at opposite end
- Available lengths: 5, 10, 20, 30, 40 or 50 meters
- Diameter: Ø 6 mm
- Color: Black

10.13 HCS-5300ZJ2 transceiver stand

- Used to install HCS-5300TD/TH/80
- Maximum height: 2.7 meters
- Weight: 3.9 kg

10.14 Earphones

■ EP-820AS Single Earphone

- Used with the receiver/conference unit
- Hi-Fi sound quality
- Ø 3.5 mm stereo plug
- 32 Ω (Tip and Sleeve, Ring: NC)
- Frequency response: 50 Hz to 20 kHz
- Sensitivity: ≥102 dBA/1 mW
- Weight: 20 g

■ EP-829 Single Earphone

- Used with the receiver/conference unit
- Hi-Fi sound quality
- Ø 3.5 mm stereo plug
- 32 Ω (Tip and Sleeve, Ring: NC)
- Frequency response: 20 Hz to 20 kHz
- Sensitivity: ≥108 dBA/1 mW
- Weight: 35 g

■ EP-830 Single Earphone

- Used with the receiver/conference unit
- Hi-Fi sound quality
- Assembled with detachable shell, cable and earphone
- The shell can be removed and cleaned separately
- The cable can be replaced separately by customer if breaks
- Ø 3.5 mm stereo plug (TRS)
- 32 Ohm (Tip and Sleeve, Ring: NC)
- Frequency response: 20 Hz to 20 kHz
- Sensitivity: ≥108 dBA/1 mW
- Weight: 25 g

■ HCS-5100PA headphone

- Used with the receiver/conference unit
- Hi-Fi sound quality
- 32 Ohm×2, Ø 3.5 mm stereo jack
- Frequency response: 20 Hz to 20 kHz
- Sensitivity: ≥108 dBA/1 mW
- Weight: 70 g

■ EP-960BH headphone

- Used with the receiver/conference unit
- Hi-Fi sound quality
- 150 Ohm×2, Ø 3.5 mm stereo jack
- Frequency response: 20 Hz to 20 kHz
- Sensitivity: ≥108 dBA/1 mW
- One sided wire
- Weight: 90 g

10.15 Connection details

■ Mains cables

- Blue Neutral
- Brown Live
- Green/Yellow Earth/Ground

■ Audio cables

Chinch connector (male)

- Pin① Signal +
- Pin② GND



■ Earphones

3.5 mm Jack plug

- Tip① Signal left
- Ring② Signal Right
- Sleeve③ Electrical earth/screen

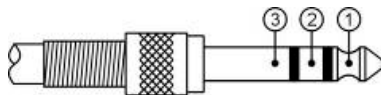

■ Emergency switch

Terminal block

Connect the emergency switch to +, -.

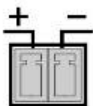

ALARM

10.16 Display language list

No	Chinese	English	Abbr.	No	Chinese	English	Abbr.	No	Chinese	English	Abbr.
0	原声	Floor	FLO	33	巴厘语	Balinese	BAN	66	加利西亚语	Galician	GLG
1	阿尔巴尼亚	Albanian	ALB	34	孟加拉国语	Bengali	BEN	67	古吉特语	Gujarati	GUJ
2	阿拉伯语	Arabic	ARA	35	缅甸语	Myanmar	MYA	68	夏威夷语	Hawaiian	HAW
3	保加利亚语	Bulgarian	BUL	36	白俄罗斯语	Belarusian	BEL	69	坎那达语	Kannada	KAN
4	加泰罗尼亚	Catalan	CAT	37	科西嘉语	Corsican	COS	70	克什米尔语	Kashmiri	KAS
5	汉语	Chinese	CHI	38	爱尔兰语	Irish	GLE	72	柬埔寨语	Cambodian	KHM
6	捷克语	Czech	CZE	39	哈萨克语	Kazakh	KAZ	73	库尔德语	Kurdish	KUR
7	丹麦语	Danish	DAN	40	吉尔吉斯语	Kirghiz	KIR	74	马拉雅拉姆	Malayalam	MAL
8	荷兰语	Dutch	DUT	41	老挝语	Lao	LAO	75	马拉地语	Marathi	MAR
9	英语	English	ENG	42	蒙古语	Mongolian	MON	76	摩尔多瓦语	Moldovan	MLD
10	芬兰语	Finnish	FIN	43	尼泊尔语	Nepali	NEP	77	恩德贝勒语	Ndebele	NDE
11	法语	French	FRE	44	塔吉克语	Tajik	TGK	78	奥里亚语	Oriya	ORI
12	德语	German	GER	45	泰语	Thai	THA	79	旁遮普语	Panjabi	PAN
13	希腊语	Greek	GRE	46	藏语	Tibetan	TIB	80	罗曼什语	Romansh	ROH
14	希伯来语	Hebrew	HEB	47	土库曼斯坦	Turkmen	TUK	81	梵文	Sanskrit	SAN
15	匈牙利语	Hungarian	HUN	48	乌克兰语	Ukrainian	UKR	82	信德语	Sindhi	SND
16	印度尼西亚	Indonesian	IND	49	越南语	Vietnamese	VIE	83	僧加罗语	Sinhalese	SIN
17	意大利语	Italian	ITA	50	粤语	Cantonese	YUE	84	梭托语	Sotho	SOT
18	日语	Japanese	JPN	51	克罗地亚语	Croatian	HRV	85	斯瓦西里语	Swahili	SWA
19	韩语	Korean	KOR	52	斯洛伐克语	Slovak	SLO	86	泰米尔语	Tamil	TAM
20	马来语	Malay	MAY	53	斯洛文尼亚	Slovenian	SLV	87	泰卢固语	Telugu	TEL
21	挪威语	Norwegian	NOR	54	爱沙尼亚语	Estonian	EST	88	茨瓦纳语	Tswana	TSN
22	波斯语	Persian	PER	55	拉脱维亚语	Latvian	LAV	89	乌尔都语	Urdu	URD
23	波兰语	Polish	POL	56	立陶宛语	Lithuanian	LIT	90	威尔士语	Welsh	WEL
24	葡萄牙语	Portuguese	POR	57	乔治亚语	Georgian	GEO	91	班图语	Bantu	BNT
25	罗马尼亚语	Romanian	RUM	58	冰岛语	Icelandic	ICE	92	祖鲁语	Zulu	ZUL
26	俄语	Russian	RUS	59	音乐	Music	MUS	93	壮族语	Zhuang	ZHA
27	塞尔维亚语	Serbian	SRP	60	未知语种	Unknown	---	94	傣族语	Dai	DIJ
28	西班牙语	Spanish	SPA	61	阿萨姆语	Assamese	ASM	95	维吾尔语	Uighur	UIG
29	瑞典语	Swedish	SWE	62	巴斯克语	Basque	BAQ	96	文莱语	Brunei	BRN
30	土耳其语	Turkish	TUR	63	达里语	Dari	PRS	97	新加坡	Singapore	SIG
31	亚美利亚语	Armenian	ARM	64	宗卡语	Dzongkha	DZO	98	印度语	Hindi	HND
32	阿塞拜疆语	Azerbaijani	AZE	65	菲律宾语	Filipino	FIL	99	缅甸语	Burmese	BUR

Appendix

Dedicated 6 PIN Extension Cable

Case 1: Soldering of S-UTP Cable and 6PIN plug/socket

1.(S-UTP) Core $4 \times 2 \times (7 \times 0.203)$ with 96-branch intertexture net

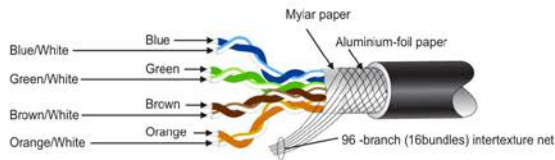

2.6P DIN Male Plug



3. 6P DIN Female Socket (insulation ring)

Front view



Rear view



4.Soldering

Socket (rear view)

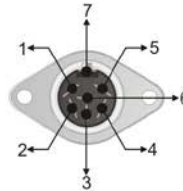

Plug (rear view)

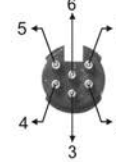

5.Soldering between dedicated 6P DIN plug/socket and the core of (S-UTP) cable

Mark (plug/socket)	Corresponding (S-UTP) core
1	Blue/White
2	Brown/White
3	Brown
4	Green, Green/White
5	Orange, Orange/White
6	Blue
7	96-branch (16-bundle) weave

Case 2: S-UTP Extension cable jointing

- Strip 30 mm insulation of both cable sheaths;
- Fan out the wires, twist the braided shield into a bundle, and cut off unnecessary foil paper and Mylar paper;



- Strip 2 mm insulation of the 8 wires; pre-tin the strands and the braided shields appropriately;
- Preassemble the heat-shrinkable tubes as in the following figure: put the $\phi 2.0$ heat-shrinkable tubes over the 8 wires, put the $\phi 4.0$ heat-shrinkable tube over the braided shield, put the $\phi 11.0$ heat-shrinkable tube over the cable sheath;
- Solder together wires having the same color (8x); solder together the braided shields;

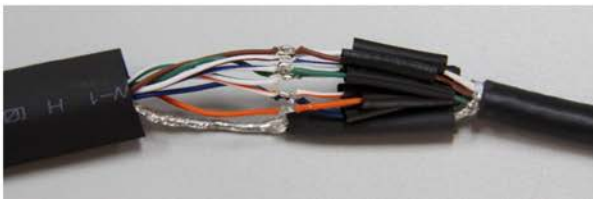

- Cover the solder joints of the 8 wires and of the braided shields with the heat-shrinkable tubes and shrink them with the electric hot-air blower;



- Shrink the heat-shrinkable tube which covers the 8 wires, the braided shield and the cable sheath with the electric hot-air blower.



TAIDEN INDUSTRIAL CO., LTD.

6/F, Block B, Future Plaza, 6060 Qiaoxiang Rd, Nanshan District, Shenzhen, China

P.C.: 518053

Website: <http://www.taiden.com>

Copyright by TAIDEN

Last Revision: 10/2021