

### Contents

#### AR-725-E-M

##### 1 Products

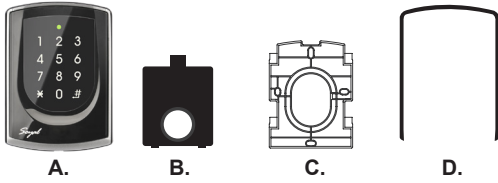

##### 2 Terminal Cables

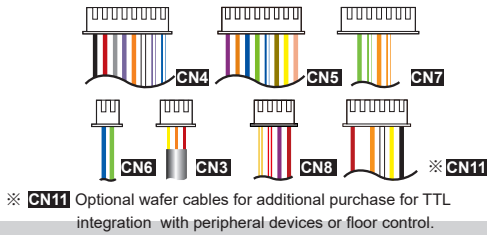

##### 3 Tools

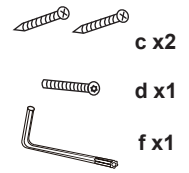

#### AR-725-E

##### 1 Products

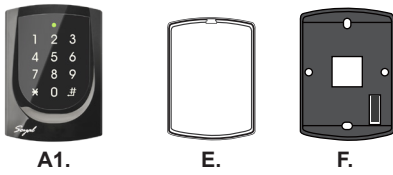

##### 2 Terminal Cables

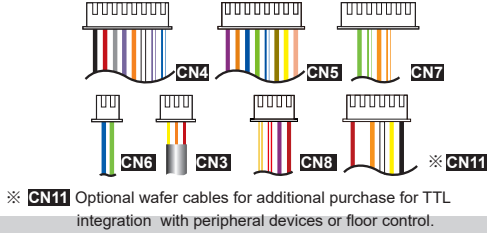

##### 3 Tools



#### AR-725 (X)

##### 1 Products

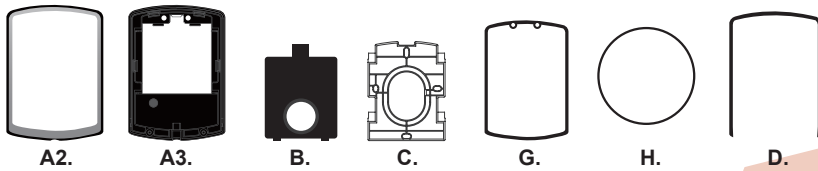

##### 2 Tools

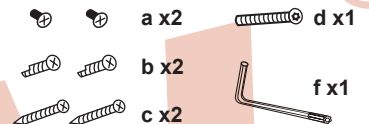

### Parts Description

- a. Button Head Pozidriv Tapping Screw: M3x10
- b. Button Head Pozidriv Slotting Screw: 2.5x10
- c. Flat Head Cap Philips Tapping Screw: 4x19.1
- d. Security Torx Screw: M3.5x15
- e. Flat Head Hex Socket Screw: M3x8
- f. Allen key

### Installation

#### AR-725-E-M

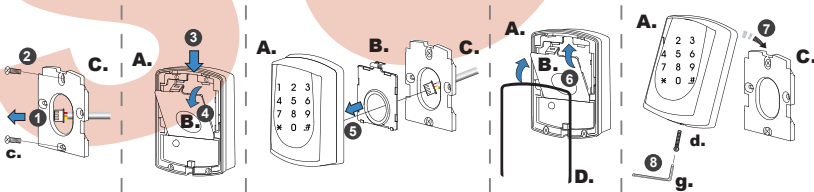

- Pull the cables from the square access hole of the mounting plate C.
- Use a screwdriver to screw the metal plate C to the wall.
- Take off the plastic mounting plate B from the body A, and pull the cables through the access hole of C and B, then connect to the body A.
- Assemble plate B with the body A, and embed the water proof strip D onto the plastic side frame.
- Assemble the body A onto the mounting plate C with the Allen key and screws (accessories supplied).
- Turn on the power and LED will light and beep will sound.

#### AR-725-E

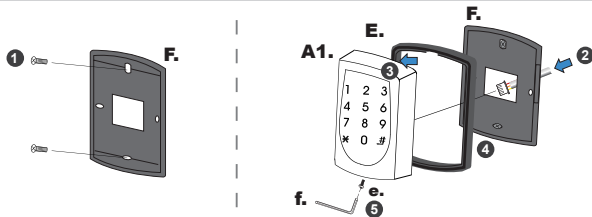

- Use a screwdriver to screw the base F onto the wall.
- Attach the water proof gasket to the body A1, and pull the cables from the square hole of the base F, and connect to the body A1.
- Assemble the body A1 with the base F.
- Screw A1 and F tight with the Allen key and screws (accessories supplied).
- Turn on the power and LED will light and beep will sound.

#### AR-725 (X)

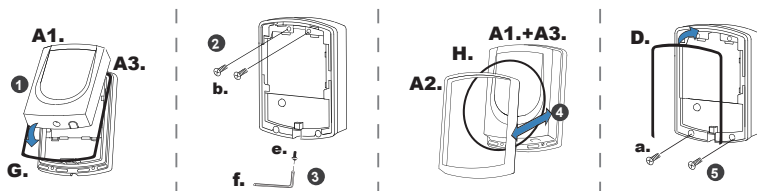

- Put on G, and attach A1 onto the plastic plate A3, and screw it with the Allen key and screws (accessories supplied).
- Put the ring O on the metal frame, and put them together onto the reader A1+A3, and screw them and buckle up the 4 buckles on the back.
- Embed the water proof strip D onto the frame side of the base.
- Following by the install process of AR-725-E-M.

### Notice

- 1. Tubing:** The communication wires and power line should NOT be bound in the same conduit or tubing.
- 2. Cable selection:** Use AWG 22-24 Shielded Twist Pair to avoid star wiring. Use CAT5 for TCP/IP connection.
- 3. Power supply:** Don't equip reader and lock with the same power supply. The power for reader may be unstable when the lock is activating, that may make the reader malfunction. The standard installation: Door relay and lock use the same power supply, and reader use independent power supply.

### Connector Table

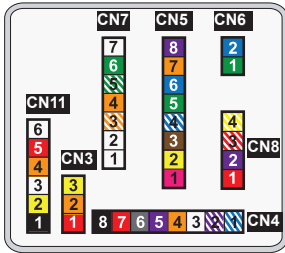

#### Cable: CN4

Wire Application	Wire	Color	Description
Lock Relay	1	Blue White	(N.O.)DC24V1Amp
	2	Purple White	(N.C.)DC24V1Amp
Common-COM-Point	3	White	(COM)DC24V1Amp
Door Contact	4	Orange	Negative Trigger Input
Exit Switch	5	Purple	Negative Trigger Input
Alarm Relay	6	Gray	Transistor Output Max. 12V/100mA (Open Collector Active Low)
Power	7	Thick Red	DC 12V
	8	Thick Black	DC 0V

#### Cable: CN5

Wire Application	Wire	Color	Description
Beeper	1	Pink	Beeper Output 5V/100mA, Low
LED	2	Yellow	Red LED Output 5V/20mA, Max
	3	Brown	Green LED Output 5V/20mA, Max
Door Output	4	Blue White	Transistor Output Max. 12V/100mA (Open Collector Active Low)
Wiegand	5	Thin Green	Wiegand DAT: 0 Input
	6	Thin Blue	Wiegand DAT: 1 Input
WG Door Contact	7	Orange	Negative Trigger Input
WG Exit Switch	8	Purple	Negative Trigger Input

#### Cable: CN7

Wire Application	Wire	Color	Description
TCP/IP Output	1	---	---
	2	---	---
	3	Orange White	Net - TX+
	4	Orange	Net - TX-
	5	Green White	Net - RX+
	6	Green	Net - RX-
	7	---	---

#### Cable: CN6

Wire Application	Wire	Color	Description
RS-485 for Lift Controller	1	Thick Green	RS-485(B-)
	2	Thick Blue	RS-485(A+)

#### Cable: CN3

Wire Application	Wire	Color	Description
Anti-Tamper Switch	1	Red	N.C.
	2	Orange	COM
	3	Yellow	N.O.

#### Cable: CN8

Wire Application	Wire	Color	Description
Power	1	Red	DC 12V Output
Security trigger signal	2	Purple	Security trigger signal Output
Arming	3	Red White	Arming Output
Duress	4	Yellow White	Duress Output

#### Cable: CN11

Optional:(Request to purchase AR-725L485 additionally)

Wire Application	Wire	Color	Description
TTL Port	1	Black	DC 0V
	2	Yellow	TX
	3	White	TE
	4	Orange	RX
	5	Red	DC 5V
	6	---	---

### Wiring Diagram

#### Connect to Electric Bolt

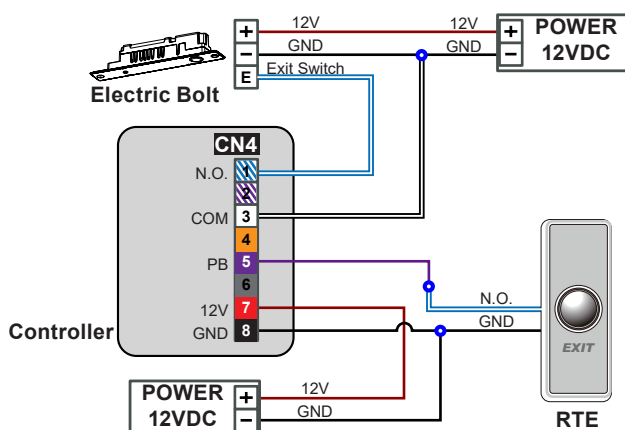

#### Connect to Magnet Lock

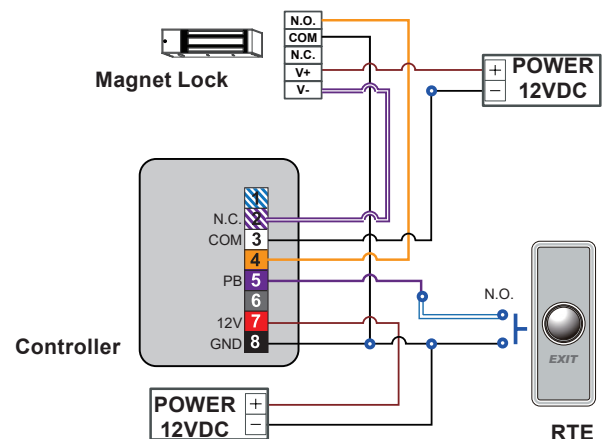

### Connect to Electric Strike

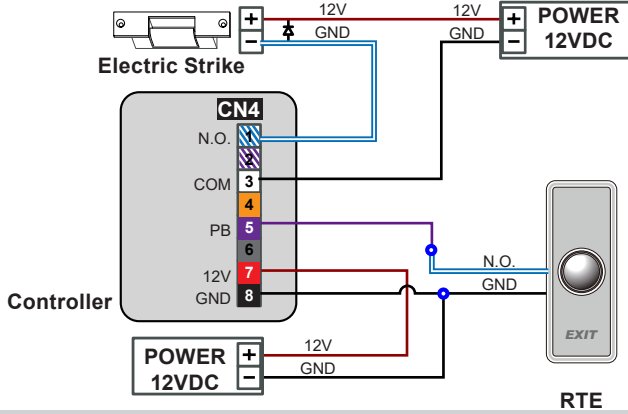

### Connect to Door Contact

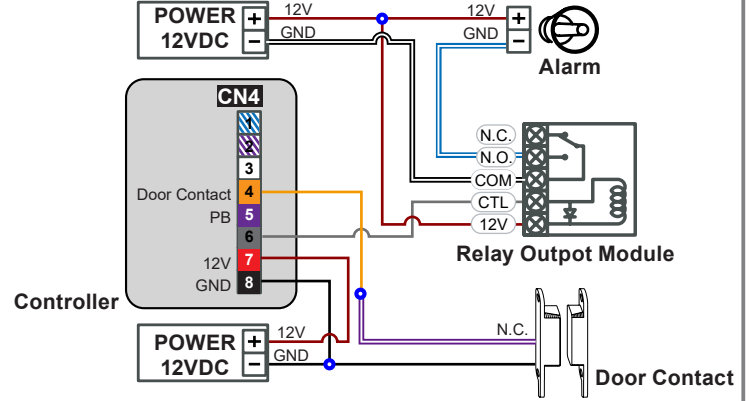

### Strengthen security with AR-721RB

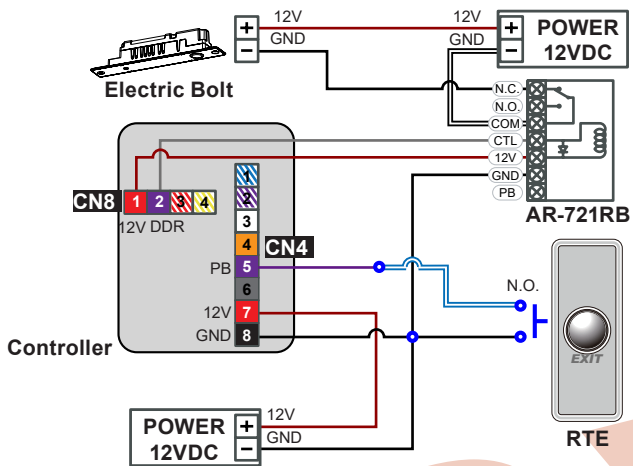

### Connect to Reader

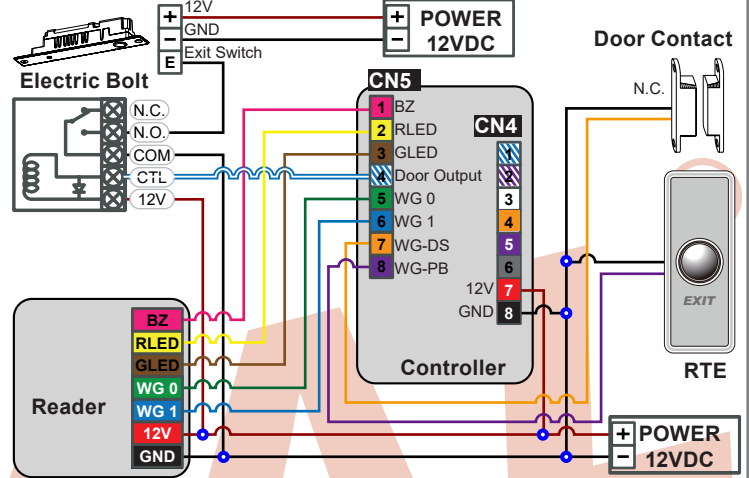

### AR-725-E become WG mode (28 \* 000 #)

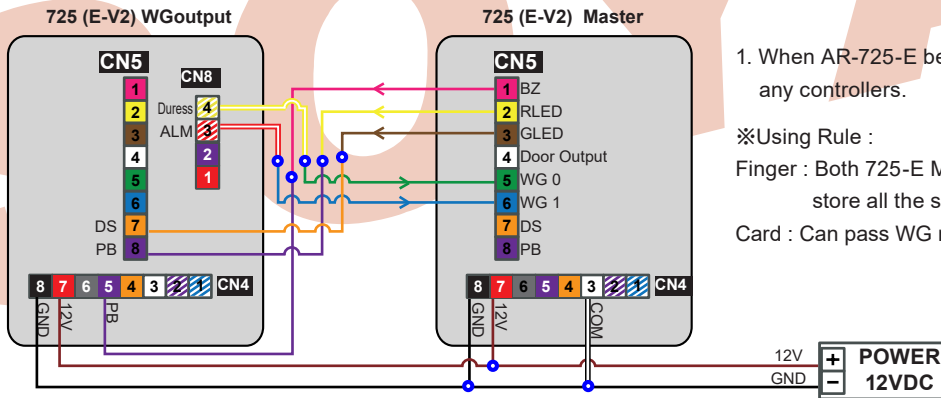

1. When AR-725-E become WG mode, it can be used with any controllers.

※Using Rule :

- Finger : Both 725-E Master mode and 725-E WG mode must store all the same FP data and real or visual card number.
- Card : Can pass WG message to controller.

### Adding and Deleting Tag

#### • Add Single Tag or Random tags

Input \*123456# (or Master Code) → 19 \*UUUUU \* 00001# → Present the tag(s) with Controller (single tag or random numbered cards one by one) → Done  
 [e.g.] 2 random cards with user addresses No. 100 and No. 101:  
 Access programming mode → 19 \* 00100 \* 00001# → Present the tags one by one → Done

#### • Add the Sequential tags

Input \*123456# (or Master Code) → 19 \*UUUUU \* QQQQ# → Present the tags (Present the tag with the lowest number first.) → OK  
 [e.g.] User Address NO.101 to NO.120 have 20 pcs of sequential tags:(62312~62332) :  
 Access programming mode → 19 \* 00101 \* 00120# → Close Tag into RF Area(only use the tag NO.62312) → OK

#### • Delete a Single Tag

Input \*123456# (or Master Code) → 10 \*SSSS 9 EEEEE#  
 [e.g.] Delete User Address: 00058  
 Access programming mode → 10 \* 00058 9 00058#

#### Tag Information



**• Delete a batch of Tags**

Input \*123456# (or Master Code) → 10\*SSSSS9EEEE#

[e.g.] Delete User Address: 00101~00245

Access programming mode → 10\*00101900245#

**• Delete All Tags**

Input \*123456# (or Master Code) → 29\*29\*#

## Programming

### A. Entering and Exiting Programming Mode

**• Entering**

Input \*123456# or \*PPPPPP#

[e.g.] The Default Value= 123456, if already changed the Master Code= 876112, input \*876112# → Access programming mode

**• Exiting**

Input \*#

**• Changing the Master Code**

Access programming mode → 09\*PPPPPPRRRRR# [Input the 6-digit new master code twice.]

[e.g.] If want to changing the Master Code= 876112, input \*123456# → 09\*876112876112#

### B. Changing the Node ID of Reader

Access programming mode → 00\*NNN\*MMM\*AAA#

[NNN= Node ID: 000~254; MMM=AR-725-E Door NO.:1~255; AAA=WG Reader Door NO.:1~255

### C. Setting up the control mode (M4/M8)

Access programming mode → 04\*N# [N=4/8]

Mode	Support	User Capacity	Access Mode	Event Capacity	120 Holidays	Duress	Time Zone	Lift Control	Anti-pass-back
M4	Networking/ Stand-Alone	16,000 (0~15,999)	1.Card only 2.Card and PIN (4-digit PIN) 3.Card or User address (5-digit) + Individual PIN (4-digit individual PIN)	32,000	V	V	unlimited	64	V
M8	Networking/ Stand-Alone	16,000 (0~15,999)	1.Card only 2.Card and PIN (4-digit individual PIN) 3.Card or PIN (4-digit individual PIN)	32,000	V	V	unlimited	64	V

### D. Setting up the password

**• Individual PWD (M4/M8)**

**Card or PIN:** Access programming mode → 12\*UUUUU\*PPPP# [e.g. User address: 00001 and PWD: 1234. Input 12\*00001\*1234#]

**Card and PIN:** Access programming mode → 13\*UUUUU\*PPPP# [e.g. User address: 00001 and PWD: 1234. Input 13\*00001\*1234#]

### E. Anti-pass-back

Usually, anti-pass-back is commonly applied to parking areas in order to prevent from multi-entry with one card at a time, or somewhere wants to monitor not only the access but also exit condition.

**• Enable device**

Access programming mode → 20\*U\*DDD# U= Enable target unit(0=AR-881EF/EV,1=Reader) [Please refer to function default value for details.]  
[e.g.] If the **AR-881EF/EV** set to **exit reader**, **WG Reader** set to **access reader**.

Access programming mode → 20\*0\*128# → 20\*1\*192# [Please refer to function default value for details.]

**• Enable card user**

Access programming mode → 26\*SSSS\*EEEE\*P# SSSS= starting user address; EEEE= ending user address [P=0 Enable/ P=1 Disable/ P=2 Reset]  
[e.g.] User address from 00152 to 00684 enable the anti-pass-back function: 26\*00152\*00684\*0#

### F. Auto Open Zone

Door will keep opening after first man flashing card. When the reader is stand-alone, supporting only 16 sets of auto-open zone by device setting. Auto-open zone can extend up to unlimited sets by Networking.

**• Enable/Disable auto open zone**

Access programming mode → 20\*U\*DDD# U= Enable target unit(0=AR-725-E,1=Reader) [Please refer to function default value for details.]  
[e.g.] If the **AR-725-E** set to **Enable aut open zone**.

Access programming mode → 20\*0\*004# [Please refer to function default value for details.]

**• Enable/Disable auto open door without presenting card**

Access programming mode → 24\*U\*DDD# U= Enable target unit(0=AR-725-E,1=Reader) [Please refer to function default value for details.]  
[e.g.] If the **WG Reader** set to **Enable aut open door without presenting card**.

Access programming mode → 24\*1\*128# [Please refer to function default value for details.]

**• Setting up access time**

Access programming mode → 08\*MW\*NN\*HHMMhhmm\*7123456H# [M=AR-725-E; W=Reader(0=disable,1=enable); NN: 16 sets of auto-open zone (NN=00~15); HHMMhhmm=Starting time to ending time; 7123456H= 7 days of week + Holiday (F= 0: disable; 1: enable)]  
[e.g.]AR-725-E (**without WG reader**), to set second time zone which could be passed only at 9:30am to 4:20pm on Mon, Wed and Fri.

Access programming mode → 08\*10\*01\*09301620\*01010100# → setting is completed

## G. Lift control

Connect with **AR-401RO16B** to control floors which the user will be able to access. [BAUD9600]

### • Single floor

Access programming mode → 27 \* UUUUU \* LL #

UUUU=User Address LL=Floor number (01~64 floor)

[e.g.] User address NO. 45 only can reach the elevator to the 24th floor: 27 \* 00045 \* 24 #

### • Multi floors

Access programming mode → 21 \* UUUUU \* G \* LLLLLLLL #

[UUUUU=User address G: 8 sets of lift control (Input: 0~7) LLLLLLLL:

8 floors setting (L=0=Disable, L=1=Enable)

[e.g.] User address NO. 168 can reach only the 6th and 20th floor:

Access programming mode → 21 \* 00168 \* 0 \* 00100000 #

Set (G)	Floor							
	L	L	L	L	L	L	L	L
0	8	7	6	5	4	3	2	1
1	16	15	14	13	12	11	10	9
2	24	23	22	21	20	19	18	17
3	32	31	30	29	28	27	26	25
4	40	39	38	37	36	35	34	33
5	48	47	46	45	44	43	42	41
6	56	55	54	53	52	51	50	49
7	64	63	62	61	60	59	58	57

## H. Setting Up the Arming

### • Conditions:

1. Arming is enabled
2. Alarm system connected

### • Application:

1. **Door open too long:** Door is open longer than door relay time plus door close time.
2. **Force open** (Opened without a valid user card): Access by force or illegal procedure.
3. **Door position abnormal:** Arming is enabled and the power is suddenly off then on.

### • Enable Arming status:

Standby Mode		Card or Passcode	Card and Passcode
<b>Card only</b>	<b>Enable all devices</b>	<b>Enable particular device</b>	<b>Card or Passcode</b>
Induct valid card → Input 4 digit arming code → * * #	Induct valid card → Input 4 digit arming code → * U # or #	Input 5 digit user address → Input 4 digit pass code → # → Input 4 digits arming code → * * # or * U #	Induct valid card → Input 4 digit pass code → # → Input 4 digits arming code → * * # or * U #
<b>Enter Program Mode</b>		<b>Enable all devices:</b> Access programming mode → * * #	
		<b>Enable particular device:</b> Access programming mode → * * U #	

### • Disable Arming status:

Standby Mode		Card or Passcode	Card and Passcode
<b>Card only</b>	<b>Disable all devices</b>	<b>Disable particular device</b>	<b>Card or Passcode</b>
Induct valid card → Input 4 digit arming code → * 9 #	Induct valid card → Input 4 digit arming code → * U # or #	Input 5 digit user address → Input 4 digit pass code → # → Input 4 digits arming code → * 9 # or * U #	Induct valid card → Input 4 digit pass code → # → Input 4 digits arming code → * 9 # or * U #

※ Factory default armingcode is: 1234. U=Reader unit (0=AR-725-E, 1=WG Reader).

## Restoring Factory Settings

### Reset all device parameters and user card data

#### • Reset all device parameters and user card data:

Access programming mode → 29 \* 29 9 #

#### • Reset all user card data:

Access programming mode → 29 \* 29 \* #

#### • Reset IP Setting:

Press "IP Resent Button" of main board for few seconds. (Reference to picture)

※ After operation as above, you will hear the long reminder sound, and wait until the sound disappear then reset the power of the controller, the device will restore factory setting.

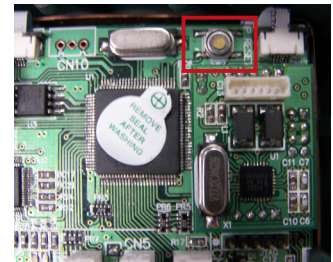

## Firmware Upgrade

### Get the upgrade software from SOYAL or our distributor and run "UdpUpdater" software

#### • Execute the software UdpUpdater.exe

The software is within SOYAL CD or Login the SOYAL web to downloads

#### • Update the firmware

[Please login the SOYAL web to download the new ISP Firmware.]

1. Input the Target Address and Port
2. [Load F/W] open the documents that have the new ISP Firmware
3. Click the new ISP Firmware and [Open] it
4. Click [Update Device] to start the firmware update
5. Till the screen shown [Firmware Update is Complete]

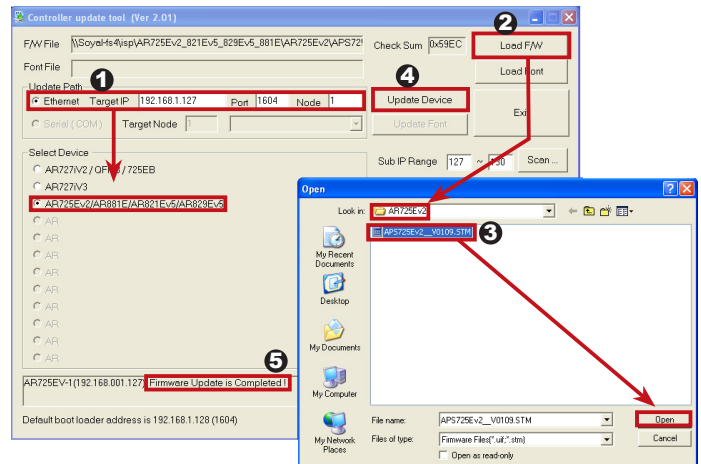

### IP Setting

- Open your Web Browser and input factory default IP address: <http://192.168.1.127>

If the IP address of AR-725-E has changed We must enter the new IP address.

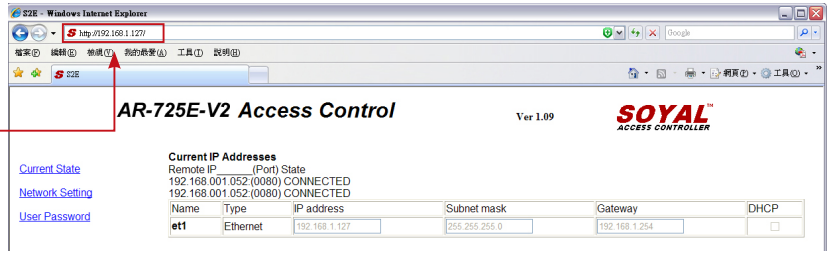

- Page menu

- [Current State](#) ← Monitor the on-line computer
- [Network Setting](#) ← IP Setting
- [User Password](#) ← Change the Log-in information

- Current State

Online Status is able to monitor and show which computer is linking on Ethernet Module

- Show which computer is linking on Ethernet Module.
- Current IP address of the AR-725-E

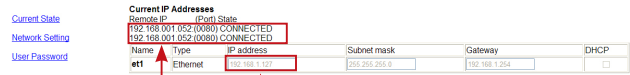

- Log-in User Password

When you choose the "Networking Setting" or "User Password" at first.

Log-in window will pop out and please input

※ At the Factory Default

User name: SuperAdm

Password: 721568

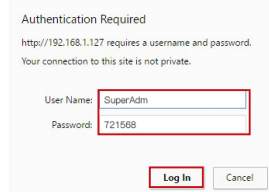

- Networking Setting

You will find initial IP Address 192.168.1.127 and check MAC Address is the same as sticker on Ethernet Module device. Please revise IP address you want, and then click "Update" button. After updating the IP, please re-connect the Web Browser by new IP address.

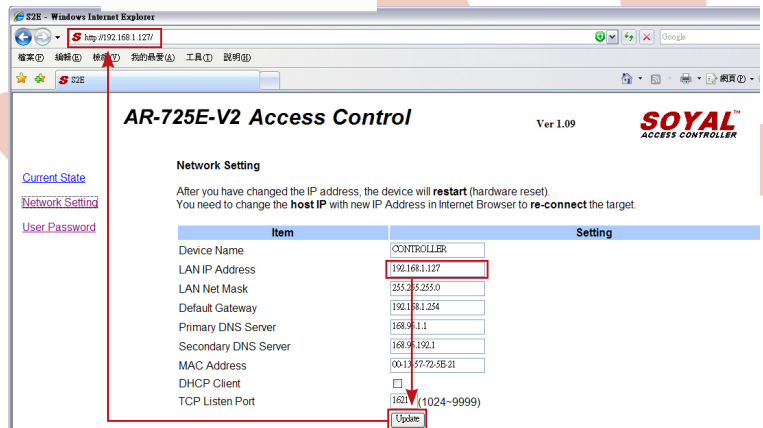

- User Password

Change the log-in password to lock the IP setting of Ethernet Module.

The password composes of 10 characters at most, it can be either A~Z or 0~9.

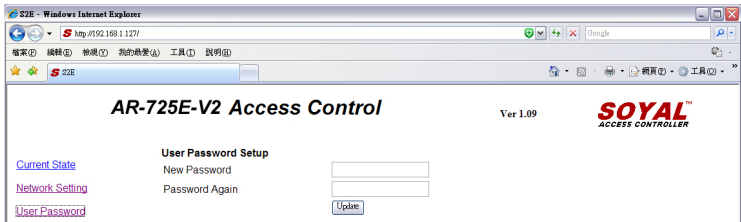

### Command List

Function	Command	Exposition
Entering programming mode	* PPPPPP #	PPPPPP: Master Code, (Default value: 123456)
Exiting programming mode	* #	
Exiting programming mode and enabling all device into arming status.	* * #	Including AR-725-E, WG Reader
Enabling each device into arming status.	* * U #	U= Enable target unit (0=AR-725-E, 1=WG Reader)
Node ID setting	00 * NNN * MMM * AAA #	NNN=Node ID,(001~254) MMM=AR-725-E Door Number,(001~255) AAA=WG Reader Door Number,(001~255)
IP Address assign (Must power reset)	01 * 0 * CCCCCCCCCC #	default value = 192.168.1.127 CCCCCCCCCCCC = 192168001127
	01 * 1 * 255255255000 #	If set to 000.000.000.000 will enable DHCP otherwise will disable DHCP
	01 * 2 * 192168001254 #	Netmask Gateway assign

### Command List

Function	Command	Exposition
Door relay time setting	02 * U * TTT #	U= Enable target unit (0=AR-725-E , 1=WG Reader) TTT= Door relay time : 000 (Output constantly) 001~600= 1-600 Sec. ; 601~609=0.1~0.9Sec.
Alarm relay time setting	03 * TTT #	TTT= Alarm relay time ; 000 (Output constantly) 001~600= 1~600 Sec.
Mode setting	04 * M #	M=4 (Mode 4) ; M=8 (Mode 8)
Arming delay time setting	05 * TTT #	Base on second, range: 001~255
Alarm delay time setting	06 * TTT #	Base on second, range: 001~255
Master card setting	07 * SSSSS * EEEEE #	SSSSS-EEEEEE=00000~15999 SSSSS= starting user address; EEEEE= ending user address
Auto-open zone setting	08 * MW * NN * HHMMhhmm * 7123456H #	M=AR-725-E; W=WG Reader (0=disable; 1=enable) NN= 16 sets of auto-open zone (Range: 00~15) HHMMhhmm=staring time to ending time (e.g.: 08301200=08:30 to 12:00) 7123456: 7 days of week -Sun/Mon/Tue/Wed/Thu/Fri/Sat (Input value: 0=disable; 1=enable) H: Holiday (Input value: 0=disable; 1=enable)
Master code settings	09 * PPPPPRRRRRR #	PPPPPP= New master code RRRRRR= Repeat the new master code
Suspend or delete tags	Suspend : 10 * SSSSS * EEEEE # Delete : 10 * SSSSS 9 EEEEE #	* :Suspend 9 :Delete SSSSS= starting user address; EEEEE= ending user address
Recover tag	11 * SSSSS * EEEEE #	SSSSS= starting user address; EEEEE= ending user address
Setting up Card or PIN mode by user address	12 * UUUUU * PPPP~PPPPPPP #	UUUUU= user address; PPPP~PPPPPPP=4digit (default)~8-digit individual PWD
Setting up Card and PIN mode by user address	13 * UUUUU * PPPP~PPPPPPP #	(Access mode: Card or PIN)
Arming output setting	14 * TTT #	Base on 1ms, range:1~255, default value=10, Input 0= Timeless
Duress code setting	15 * PPPP #	PPPP= 4-digit PWD (0001-9999) Default value : 0000
Card number modification	16 * UUUUU * SSSSSCCCCC #	UUUUU=user address SSSSS=5 digit site code ; CCCCC=5 digit card code
Arming PWD setting	17 * PPPP #	PPPP= 4-digit PWD (0001-9999) Default value : 1234
Enabling or Disabling into arming status	Card+NNNN #	NNNN : Arming PWD
Enabling or Disabling each device into arming status.	Card+NNNN * U #	U= Enable target unit (0=AR-725-E , 1=WG Reader)
Enabling all device into arming status.	Card+NNNN * * #	
Disabling all device into arming status.	Card+NNNN * # 9	
Door open waiting time	18 * U * TTT #	U= Enable target unit (0=AR-725-E , 1=WG Reader) TTT=Door open waiting time:001~600;default value:15 sec.
Add card by presenting	19 * UUUUU * QQQQQ #	UUUUU=user address QQQQQ=Card quantity(00001=Continuously inducting)
Reader additional setting	20 * U * DDD #	U= Enable target unit (0=AR-725-E , 1=WG Reader) DDD=Function default value
Lift control setting: multi-doors	21 * UUUUU * G * LLLLLLL #	UUUUU=user address ; G=4 sets of lift control(0~3); LLLLLLLL=8 assigned floor (F=0: Disable, 1: Enable)
Add/Delete tag by presenting (M6 only)	22 * N #	N=0(Delete tag); N=1(Add tag)
AR-401RO16/ AR-401RO16B relay time setting	23 * MMM * TTT #	MMM=Node ID of lift controller TTT= relay time: 000~600=1~600 sec.
Factory setting	24 * U * DDD #	U= Enable target unit (0=AR-725-E , 1=WG Reader) DDD : Function default value
Real time clock setting	25 * YYMMDDHHMMSS #	YYMMDDHHmmSS: Year/Month/Day/Hour/Min./Sec.
Anti-pass-back (Enable user)	26 * SSSSS * EEEEE * P #	SSSSS= starting user address; EEEEE= ending user address P=0=Enable; P=1=Disable; P=2=Initial
Lift control setting: single door	27 * UUUUU * LL #	UUUUU= user address ; LL : Floor number(01~64 floor)
Duress Function and Arming output setting	28 * FFF #	Arming output and Duress function: FFF= 008 (default value)
Delete all tag	29 * 29 * #	

# Access controller

Illuminated Touch-panel

V200422

## Command List

Function	Command	Exposition
Same tag reading interval time	31 * TTTT #	Base on 10ms, range from 10 to 6000
Auto ring the clock alarm schedule	32 * SS * HHMMTT * 7123456H #	SS= 16 sets auto alarm schedule, range 0~15 HHMM= HH:MM (ex. 0830: Ring bell at 08:30) TT=Period of time to ring bell (Base on second, range 01~99 sec.) 7123456: 7 days of week -Sun/Mon/Tue/Wed/Thu/Fri/Sat (Input value: 0=disable; 1=enable) H: Holiday (Input value: 0=disable; 1=enable)
Holiday Setting	35 * MMDD * F #	MM= Month of year (01=Jan...10=Oct.) DD= Date of month (01=1st day of month) F= 0:Delete ; 1: Add
Enabling or Disabling into Full Access status	36 * MW #	M=AR-725-E; W=WG Reader (0=disable; 1=enable)
RS485 port function setting (Needs to be restarted after setting)	37 * AB #	A=0:AR401RO                      B=0: 9600(default value) 1:Host (default value)            1: 19200 2:LED Panel                        2: 38400 3:Printer                            3: 57600
TTL port BAUD setting	38 * DDD #	DDD : 001=4800 bps                DDD : 065=9600 bps DDD : 129=19200 bps
Change WG bits output format	41 * n #	n : 0=WG26 ; n : 1=WG34
PIN & UID Length setting	42 * m * n #	m=PIN code Length 4~8 Digit / n= UID Length 2~8 Digit

## Function Default Value

20 * U * DDD # <span style="float:right">※Default Value</span>					
Function	Option		Value	Bit	Application
Entry and Exit Access is recorded on Duty Report	※0: Yes	1: No	001	0	Networking
Activate close door automatically lock (Auto-Relock)	※0: Disable	1: Enable	002	1	Networking/Stand-Alone
Auto Open	※0: Disable	1: Enable	004	2	Networking/Stand-Alone
When Access Mode is "Card and PIN", Readers can skip pressing PIN code	※0: Disable	1: Enable	008	3	Networking/Stand-Alone
Exit by Push Button	0: Disable	※1: Enable	016	4	Networking/Stand-Alone
Enable force Open trigger alarm	※0: Disable	1: Enable	032	5	Networking
Entry/Exit Reader	※0: Exit	1: Entry	064	6	Networking
Anti-pass-back	※0: Disable	1: Enable	128	7	Networking

24 * U * DDD # <span style="float:right">※Default Value</span>						
Function	Option		Value	Bit	Application	
Enable Egress Beep Sounds	※0: Enable		1: Disable	001	0	Networking/Stand-Alone
----	----		----	002	1	----
----	----		----	004	2	----
Arm/Disarm Zone(Zone: 62)	※0: Enable		1: Disable	008	3	Networking/Stand-Alone
Reader and controller share the same door relay (only for WG reader)	0: Disable		※1: Enable	016	4	Networking/Stand-Alone
Free Access Mode	※0: Disable		1: Enable	032	5	Networking/Stand-Alone
Stop alarm by pressing push button or closing the door	※0: Disable (must swipe valid card)		1: Enable	064	6	Networking/Stand-Alone
Enter auto open time zone without presenting valid card	※0: Disable (must present valid card first)		1: Enable	128	7	Networking/Stand-Alone

28 * FFF # <span style="float:right">※Default Value</span>					
Function	Option		Value	Bit	Application
Expiry User Access Trigger Alarm	※0: Disable	1: Enable	001	0	Networking/Stand-Alone
Reset Anti-Passback on Timezone 61	※0: Disable	1: Enable	002	1	Networking/Stand-Alone
---	----		004	2	----
Duress and Arming Output function	0: Wiegand Output	1: Arming and Duress Output	008	3	Networking/Stand-Alone
RS-485	Lift Control: 0		000	4-5	Networking/Stand-Alone
	Host: 1		016		
	LED Board: 1		032		
	Printer: 1		048		
----	----		032	6	----
----	----		064	7	----

※ U=Controller/Reader  
(0= Master Controller;  
1= Slave Reader);  
DDD= Weighted Value

### Weighted Value Manual

**Step 1:** Select the 'Function' that you need for each command

(20\*, 24\*, 28\*)

**Step 2:** 'Option' of function that you need, it is either 0/1 option value.

**Step 3:** Subtract the 'Value' of each Option with 'Option' Value.

### Example 1:

Setting up Main Controller under command 20\* for function 'Enable force Open trigger alarm' + 'Entry Reader' + 'Anti-pass-back' = (1\*032) + (1\*064) + (1\*128) = weighted value 224; enter 24\*0\*224#