

Edgelit Thermoplastic Exit Sign

Project:	
Type:	
Catalog #:	

STANDARD



OPTIONAL

ILLUMINATION

- Ultra bright, energy efficient, long life Red or Green LEDs.
- UV-stabilized ultra-clear acrylic edgelit panel provides consistent, uniform illumination.
- Double face utilizes factory installed silver or white mylar background panel.

ELECTRICAL

- Dual 120/277 voltage standard.
- Unique bi-color LED indicator light alerts occupant on battery condition (Green-normal, Red-check battery).
- Push-to-test switch for mandated code compliance testing.
- 4.8V long life maintenance-free, rechargeable NiCd battery (EM models only).
- Internal solid-state transfer switch automatically connects the internal battery to LED board for minimum 90-minute emergency illumination.
- Fully automatic solid-state, two rate charger initiates battery charging to recharge a discharged battery in 24 hours.

MOUNTING

- EZ-snap mounting canopy included for top, end or back mount.

HOUSING

- Injection-molded, engineering grade 5VA, flame retardant, high-impact resistant thermoplastic housing in silver, white, or black finish.
- Self-adhesive Chevron appliques and guide template provided for directional indication.

ORDERING INFORMATION

MODEL	No. of FACES	LETTER COLOR	PANEL	HOUSING COLOR	BATTERY	OPTIONS
PLELRXTEU	1	Single Face	R Red	C Clear ¹	W White	(blank) AC-Only
	2	Double Face	G Green	M Mirror	B Black	EM Battery Backup
				W White	A Silver	
						CUSTOM Custom Wording
						SDT Self-Diagnostics ²
						2C-120 Dual Circuit with 120V input ³
						2C-277 Dual Circuit with 277V input ³
						SPV 208/220/240 Volt, 50/60Hz ⁴

¹ With single face only.

² Available only with EM units.

³ Available only with AC units.

⁴ Not available with SDT.



OPTIONS

- Custom: Signs available with requested 'special' wording.
- SDT: Self-diagnostic feature performs monthly, biannual, and annual tests to ensure reliable operation and meets electrical and life safety codes.
- 2C-120V/2C-277V: Dual circuit option on the AC-only unit enables it to be connected to two different power supplies at the same time.
- SPV: UL Listed for 208/220/240 Volt, 50/60Hz.

WARRANTY / LISTING

- Five year warranty on all electronics and housing. Battery is prorated for five years.
- Meets UL924, NFPA 101 Life Safety Code, NEC, OSHA, Local and State Codes.
- UL Listed for damp locations (0°C – 50°C).
- Certified to CEC under Title 20 Regulations.

DIMENSIONS

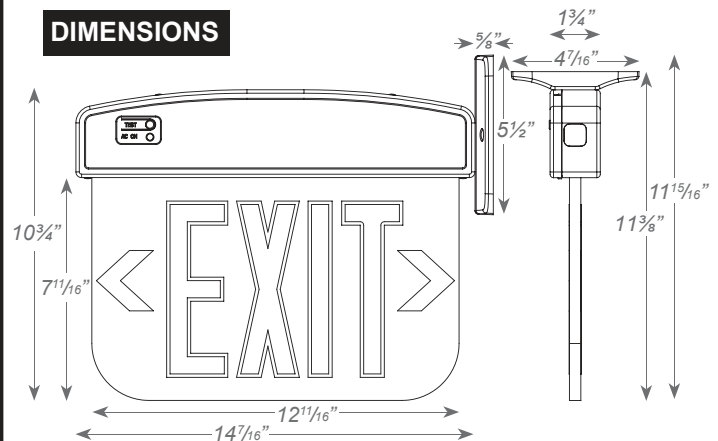

Sample Part Number: PLELRXTEU1RCAEM

Edgelit Thermoplastic Exit Sign

Project:	
Type:	
Catalog #:	

ELECTRICAL INFORMATION

CATALOG NUMBER	INPUT WATTS (W)					INPUT AMPS (A)				
	120V	277V	208V	220V	240V	120V	277V	208V	220V	240V
PLELRXTEU-RED/GREEN/EM/SPV	3.6	4.0	3.84	3.9	3.95	0.031	0.020	0.022	0.021	0.020
PLELRXTEU-RED/GREEN 2C/SDT	3.6	4.0	-	-	-	0.031	0.020	-	-	-