

# BW ROLLER CHAIN

## SIZES AND DIMENSIONS

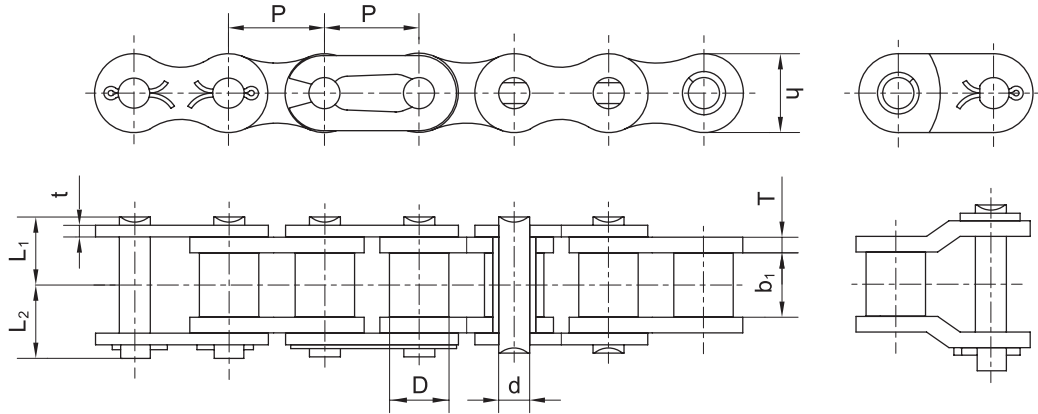

### BSI Standard - Short Pitch Roller Chain Single Strand / Drive Chain



DIN/ISO Chain No.	Pitch	Width Between Inner Plate	Roller Diameter	Pin Diameter	Pin Length		Inner Plate Depth	Plate Thickness	Ultimate Tensile Strength	Average Tensile Strength	Weight per meter
	<b>P</b>	<b>b<sub>1</sub> min</b>	<b>D max</b>	<b>d</b>	<b>L<sub>1</sub></b>	<b>L<sub>2</sub></b>	<b>h</b>	<b>t/T</b>	<b>Q min</b>	<b>Q<sub>0</sub></b>	<b>q</b>
	mm	mm	mm	mm	mm		mm	mm	kN	kN	kg/m
05B-1	8	3	5	2.31	3.9	4.8	7	0.75	4.4	5.9	0.19
06B-1	9.525	5.72	6.35	3.28	6.27	7.23	8.2	1.0/1.27	8.9	10.5	0.39
08B-1	12.7	7.75	8.51	4.45	8.5	9.9	11.8	1.65	17.8	20.5	0.75
10B-1	15.875	9.65	10.16	5.08	9.6	10.9	14.6	1.65	22.2	27.5	0.95
12B-1	19.05	11.68	12.07	5.72	11	12.4	16	1.8	28.9	32.5	1.22
16B-1	25.4	17.02	15.88	8.28	17.65	19.05	20.9	3.2/4	60	71	2.8
20B-1	31.75	19.56	19.05	10.19	20.2	23.8	26	3.6/4.5	95	107	3.9
24B-1	38.1	25.4	25.4	14.63	26.65	31.05	33	5/6	160	178	7.13
28B-1	44.45	30.99	27.94	15.9	32.55	36.45	36.7	6.2/7.5	200	225	9.36
32B-1	50.8	30.99	29.21	17.81	32.8	37.2	41.9	6.2/7	250	278	9.94

Connecting Type: The series less than 16B (including 16B) is preferred for spring clip type;  
The series larger than 20B (including 20B) is preferred for cottered type.

# BW ROLLER CHAIN

## SIZES AND DIMENSIONS



### BSI Standard - Short Pitch Roller Chain Double Strand / Drive Chain

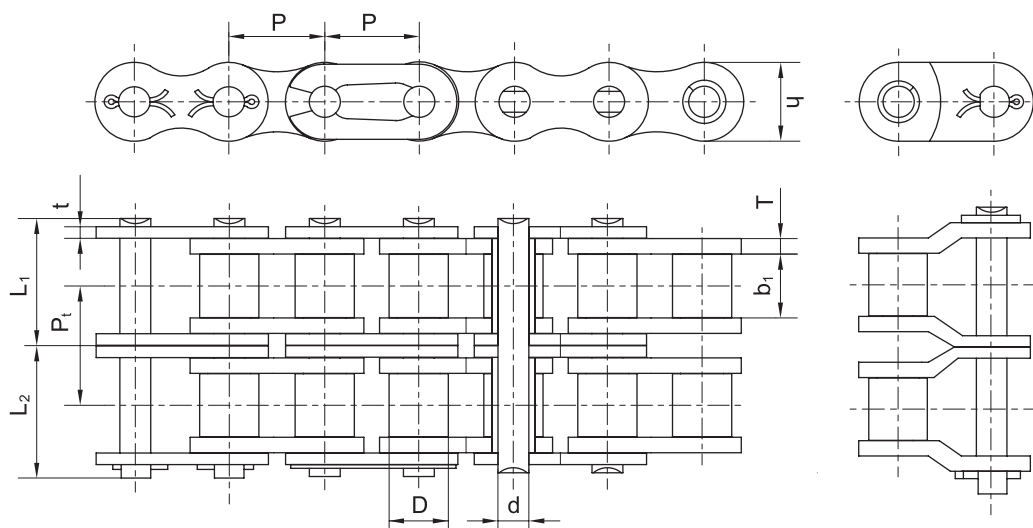

DIN/ISO Chain No.	Pitch	Width Between Inner Plate	Roller Diameter	Pin Diameter	Pin Length		Inner Plate Depth	Plate Thickness	Transverse Pitch	Ultimate Tensile Strength	Average Tensile Strength	Weight per meter
	<b>P</b>	<b>b<sub>1</sub> min</b>	<b>D max</b>	<b>d</b>	<b>L<sub>1</sub></b>	<b>L<sub>2</sub></b>	<b>h</b>	<b>t/T</b>	<b>P<sub>t</sub></b>	<b>Q min</b>	<b>Q<sub>0</sub></b>	<b>q</b>
	mm	mm	mm	mm	mm		mm	mm		kN	kN	kg/m
05B-2	8	3	5	2.31	6.75	7.59	7	0.75	5.64	7.8	10.2	0.38
06B-2	9.525	5.72	6.35	3.28	11.4	12.4	8.2	1.0/1.27	10.24	16.9	18.9	0.74
08B-2	12.7	7.75	8.51	4.45	15.5	16.9	11.8	1.65	13.92	31.1	37	1.47
10B-2	15.875	9.65	10.16	5.08	17.9	19.3	14.6	1.65	16.59	44.5	53.8	1.88
12B-2	19.05	11.68	12.07	5.72	20.75	22.15	16	1.8	19.46	57.8	65.3	2.42
16B-2	25.4	17.02	15.88	8.28	33.6	35	20.9	3.2/4	31.88	106	128.3	5.54
20B-2	31.75	19.56	19.05	10.19	38.45	42.05	26	3.6/4.5	36.45	170	210	7.71
24B-2	38.1	25.4	25.4	14.63	50.85	55.25	33	5/6	48.36	280	313.6	14.09
28B-2	44.45	30.99	27.94	15.9	62.35	66.15	36.7	6.2/7.5	59.56	360	403.2	18.49
32B-2	50.8	30.99	29.21	17.81	62.05	66.45	41.9	6.2/7	58.55	450	504	19.59

Connecting Type: The series less than 16B (including 16B) is preferred for spring clip type;  
The series larger than 20B (including 20B) is preferred for cottered type.

# BW ROLLER CHAIN

## SIZES AND DIMENSIONS



### BSI Standard - Short Pitch Roller Chain

#### Triple Strand / Drive Chain

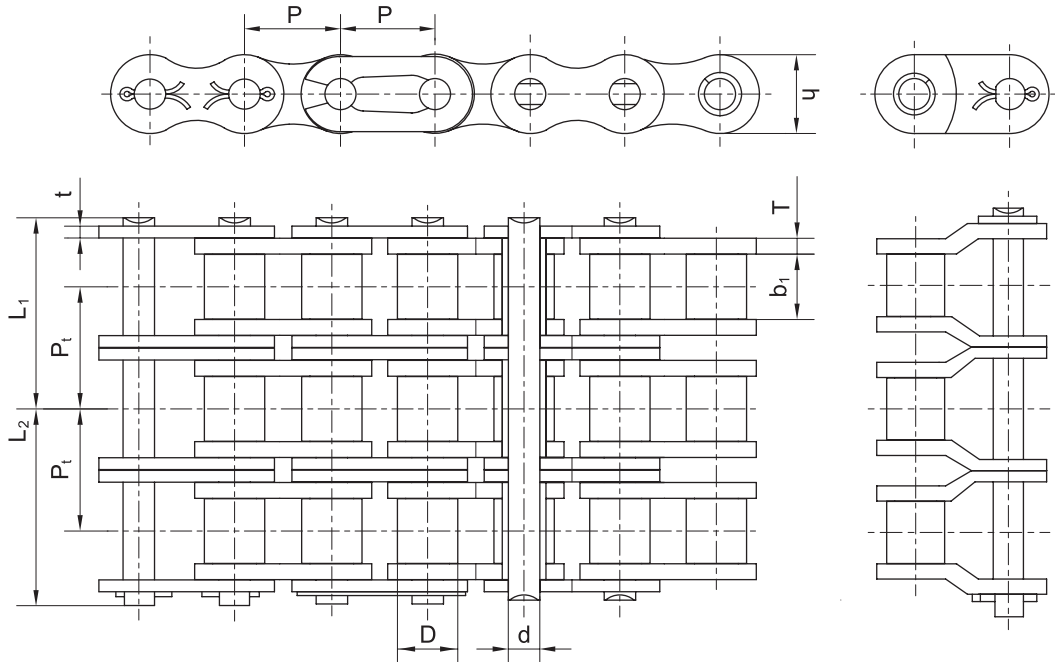

DIN/ISO Chain No.	Pitch	Width Between Inner Plate	Roller Diameter	Pin Diameter	Pin Length		Inner Plate Depth	Plate Thickness	Transverse Pitch	Ultimate Tensile Strength	Average Tensile Strength	Weight per meter
	<b>P</b>	<b>b<sub>1 min</sub></b>	<b>D<sub>max</sub></b>	<b>d</b>	<b>L<sub>1</sub></b>	<b>L<sub>2</sub></b>	<b>h</b>	<b>t/T</b>	<b>P<sub>t</sub></b>	<b>Q<sub>min</sub></b>	<b>Q<sub>0</sub></b>	<b>q</b>
	mm	mm	mm	mm	mm		mm	mm		kN	kN	kg/m
05B-3	8	3	5	2.31	9.55	10.45	7	0.75	5.64	11.1	13.8	0.56
06B-3	9.525	5.72	6.35	3.28	16.5	17.5	8.2	1.0/1.27	10.24	24.9	30.1	1.1
08B-3	12.7	7.75	8.51	4.45	22.45	23.85	11.8	1.65	13.92	46.65	56	2.18
10B-3	15.875	9.65	10.16	5.08	26.2	27.6	14.6	1.65	16.59	66.7	83.4	2.82
12B-3	19.05	11.68	12.07	5.72	30.5	31.9	16	1.8	19.46	86.7	99.7	3.41
16B-3	25.4	17.02	15.88	8.28	49.55	50.95	20.9	3.2/4	31.88	160	200	8.28
20B-3	31.75	19.56	19.05	10.19	56.65	60.25	26	3.6/4.5	36.45	250	287.5	11.53
24B-3	38.1	25.4	25.4	14.63	75.05	79.45	33	5/6	48.36	425	488.8	20.79
28B-3	44.45	30.99	27.94	15.9	92.15	96.05	36.7	6.2/7.5	59.56	520	592.8	27.78
32B-3	50.8	30.99	29.21	17.81	91.35	95.75	41.9	6.2/7	58.55	507	578.1	29.25

Connecting Type: The series less than 16B (including 16B) is preferred for spring clip type;  
The series larger than 20B (including 20B) is preferred for cottered type.