

## Series S78K2 Planetary Auger drive Service & Repair Manual

REF: ..... SMS78K2-5P5F58RK2-AB  
CREATED: ... MAR, 2007

# S78K2 SERVICE MANUAL

## PLANETARY AUGER DRIVE WITH AUTOMATIC KICKDOWN

This manual will assist in disassembly and assembly of the above model auger drive. Item numbers, indicated in parentheses throughout this manual, refer to the exploded parts breakdown drawing. Individual customer specifications (output shaft hex size, motor, bail assembly, etc.) may vary from exploded drawing and standard part numbers shown. If applicable, refer to individual customer drawing for details.

For any spare or replacement parts, contact your distributor or equipment manufacturer. Always try to have available the auger drive unit part number, serial number and date code on the serial tag. This information may be necessary for verification of any component part numbers. Component part numbers and/or manufacturing lot numbers may be stamped on individual parts. This information may also be helpful in identifying replacement components.

### LUBRICATION & MAINTENANCE

Using the chart below, determine an appropriate lubricant viscosity. Use only EP (extreme pressure) or API GL-5 designated lubricants. Change the lubricant after the first 50 hours of operation and at 500 hour intervals thereafter. The digger drive should be partially disassembled to inspect gears and bearings at 1000 hour intervals.

**Recommended ambient and operating temperatures for conventional and synthetic gear lubricants**

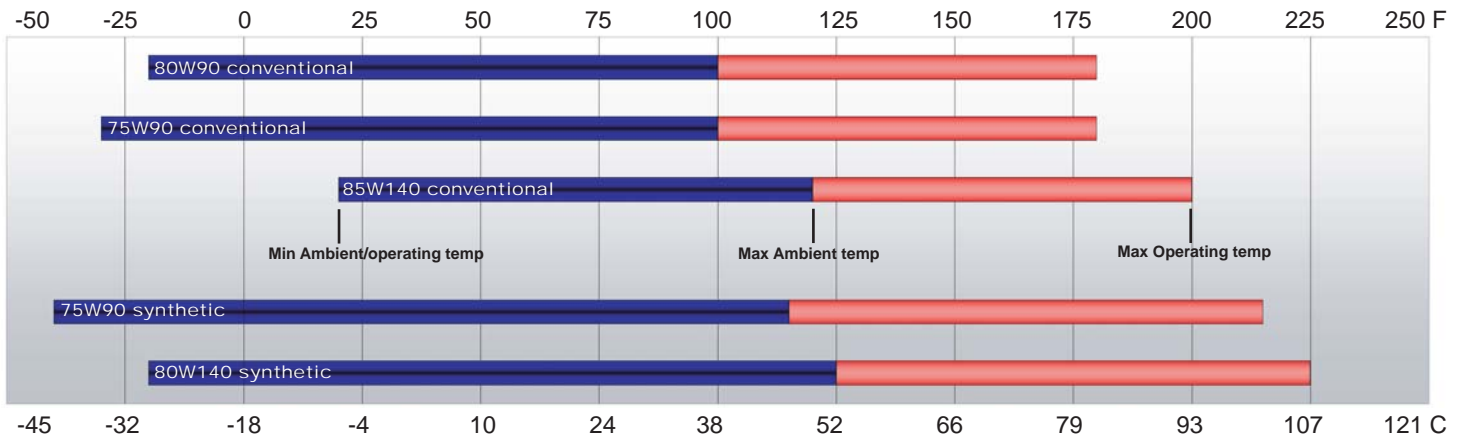

**Note:** Ambient temperature is the air temperature measured in the immediate vicinity of the gearbox. A Gearbox exposed to the direct rays of the sun or other radiant heat sources will operate at higher temperatures and therefore must be given special consideration. The max operating temp must not be exceeded under any circumstances, regardless of ambient temperature

**WARNING:** While working on this equipment, wear adequate protective clothing, hearing, eye, and respiratory protection. Use safe lifting procedures.

**ESCHSCHMIDT****HYDRASYNC MODELS S78-35 & S78-48  
PLATE RETAINED SHAFT**EFFECTIVE:  
FROM: S/N 26207 09-15-99 Drawing Modified for Model: S7848-5P5F58RK2  
TO: CURRENT

ITEM	QTY	DESCRIPTION	S78-35	S78-48
1	1	COVER - 'C' MOUNT	80-004-1174	80-004-1174
2	1	OUTPUT SHAFT 2-1/2" HEX	71-004-4022	71-004-4022
		OUTPUT SHAFT 2-5/8" HEX	71-004-4032	71-004-4032
3	1	BEARING CUP - LOWER	01-103-0080	01-103-0080
4	1	BEARING CARRIER	71-004-2144	71-004-2144
5	1	RING GEAR, SEC.	71-004-0042	71-004-0042
6	1	RING GEAR, PRI.	73-004-1063	73-004-1063
7	1	CARRIER-PRI.	73-004-1043	73-004-1053
8	1	CARRIER-SEC.	71-004-0073	71-004-0073
9	1	INPUT GEAR	73-004-1012	73-004-1002
10	3	PLANET SHAFT-PRI.	71-004-0121	71-004-0121
11	3	PLANET SHAFT-SEC.	71-004-0081	71-004-0081
12	6	WASHER-PRI.	71-004-0861	71-004-0861
13	6	WASHER-SEC.	71-004-0871	71-004-0871
14	3	PLANET GEAR-PRI.	73-004-1032	73-004-1022
15	3	PLANET GEAR-SEC.	71-004-0092	71-004-0092
16	1	SUN GEAR	71-004-0102	71-004-0102
17	1	BEARING CONE - UPPER SHAFT	01-102-0100	01-102-0100
18	3	BEARING - PLANET SEC.	01-105-0020	01-105-0020
19	6	BEARING - PLANET PRI.	01-105-0010	01-105-0010
20	1	BEARING CUP - UPPER	01-103-0090	01-103-0090
21	1	PLATE-BRG RETAINER	71-004-2322	71-004-2322
22	12	H.H.C.S. 3/8-16 X 6-1/2	01-150-0020	01-150-0020
23	6	ROLL PIN (3/16 X 1)	01-153-0020	01-153-0020
24	12	HEX FLANGE NUT (3/8-16)	01-158-0360	01-158-0360
25	1	RETAINING RING	01-160-0030	01-160-0030
27	1	BEARING CONE - LOWER	01-102-0090	01-102-0090
28	1	HOLLOW HEX PLUG (1/2 NPT)	01-207-0010	01-207-0010
29	3	SOCKET HD CAPSCREW	01-150-1480	01-150-1480
30	3	O-RING	01-402-0020	01-402-0020
31	1	O-RING	01-402-0010	01-402-0010
32	2	H.H.C.S. (5/8-11 X 2)	01-150-0050	01-150-0050
33	2	LOCKWASHER (5/8)	01-166-0040	01-166-0040
34	1	MOTOR	<b>01-304-0580</b>	
35	1			
		BAIL ASSY (1-1/2" BAIL BOSS DIA)		S73-005
36	1	SEAL	01-405-0540	01-405-0540
37	1	HOLLOW HEX PLUG NO 12 SAE	01-208-0030	01-208-0030

**Kickdown Parts**

38	1	VALVE BODY 2-DIRECTION (K2)	01-308-0150	01-308-0150
39	1	KIT-TUBE AS&FIT'G KICKDOWN-58	01-309-0580	01-309-0580
		KIT-TUBE AS&FIT'G KICKDOWN 61	01-309-0610	
40	1	FITTING, K2 ONLY	01-316-0020	01-316-0020
41	2	H.H.C.S. 1/4-20 X 1-3/4 GR5	01-150-1690	01-150-1690
42	2	FLAT WASHER 1/4"	01-166-0390	01-166-0390

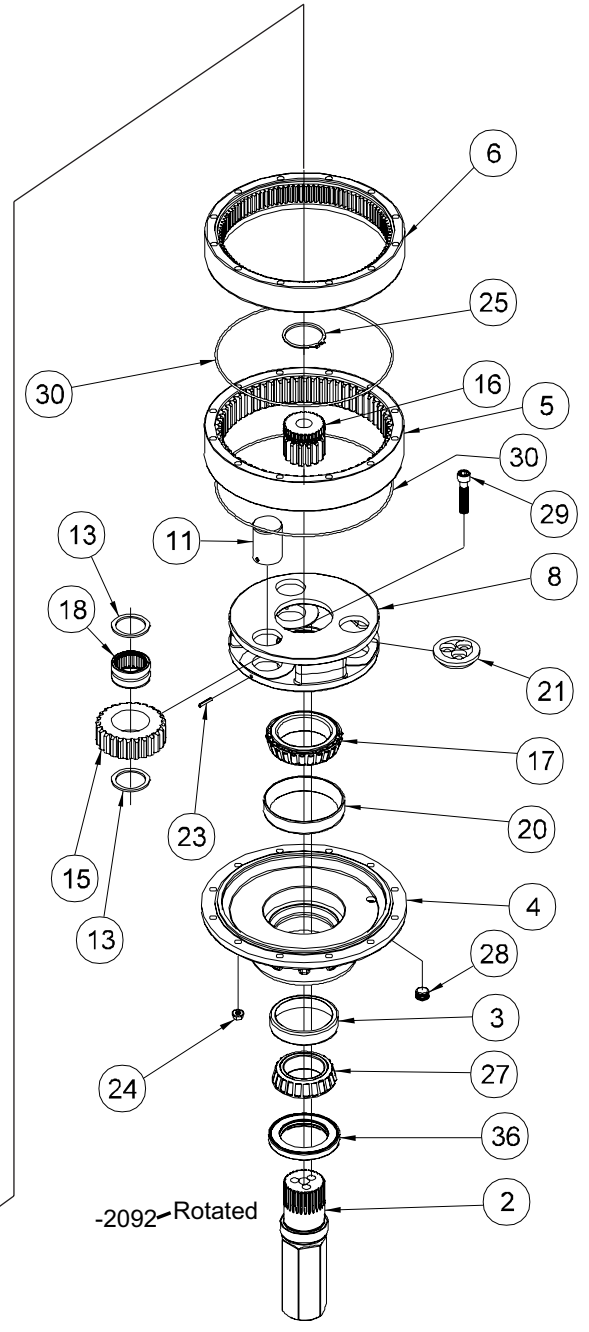
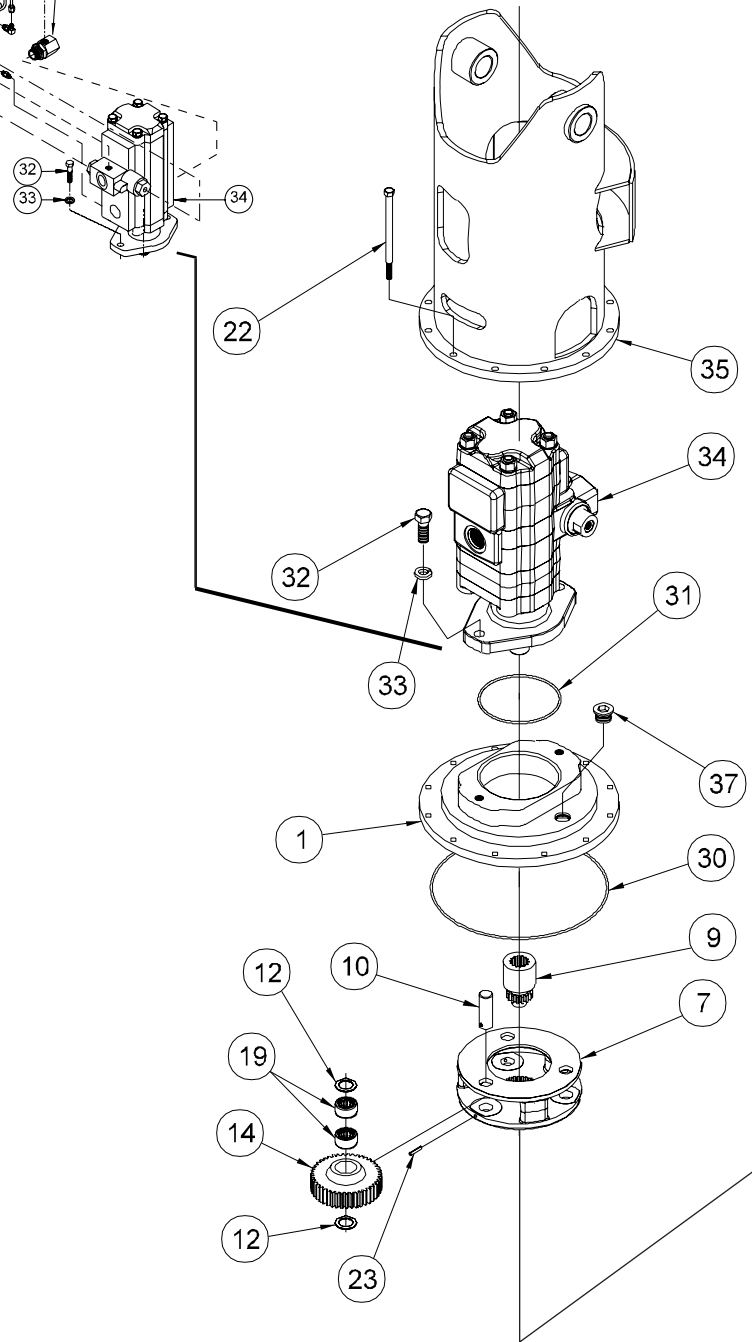
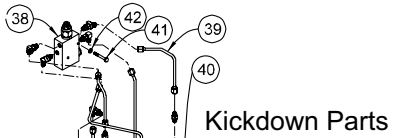

OPTIONS  
 SEAL KIT P/N 76-016-2011  
 INCLUDES 3 OF ITEM 30, AND  
 1 EA. OF ITEMS 31 AND 36

DATE: 11-07-02  
 FILENAME: X7848-5P5F58RK2-JTS

# Unit Disassembly Procedure

(Refer to exploded view drawing)

- 1) Scribe a diagonal line, from the bail (35) to the bearing carrier (4), across the outside of the auger drive to assure proper orientation of parts as they are reassembled.
  - 2) To drain oil, position unit on its side and remove oil plug (28) located in bearing carrier (4). To help ventilate oil while draining, loosen or remove oil plug (37) located in cover (1). Maximum drainage occurs when oil is warm.
- 3) Remove the kickdown valve body (38) by loosening the two hex head cap screws (41) and associated tubing and fittings (39). The hex head cap screws are trapped between the mounting plate on the bail and the motor. They can only be removed once the valve body has been removed. The tubes and small fittings on the kickdown mechanism are not serviced separately but as a kit which contains all the necessary fittings and tubing. If these are not damaged, they can be reused.
  - 4) Remove the large fitting (40) from the motor outlet.
  - 5) Remove the twelve hex head cap screws (22) and hex flange nuts (24) from bail (35). Lift bail from unit.

**NOTE: There are no bolts retaining the major components together. Proceed with caution when moving the unit.**

- 6) Remove the two cap screws (32) and lock washers (33) from hydraulic motor (34). Remove motor from unit. Check o-ring (31) for damage.
- 7) Remove the cover (1), input gear (9), and o-ring (30).
- 8) Lift the primary planet carrier assembly out of the unit
- 9) If sun gear (16) has not been removed from auger drive, do so now. (Sometimes the sun gear remains in the primary carrier (7).)
- 10) Remove primary ring gear (6) and o-ring (30).
- 11) Remove retaining ring (26) from end of output shaft (2).
- 12) Lift the secondary planetary assembly out of the unit. Use a puller if necessary.
- 13) Remove secondary ring gear (5) and o-ring (30).
- 14) The unit is now disassembled into groups of parts. The area(s) requiring repair should be identified by thorough inspection of the parts after they have been cleaned and dried.

## Primary Planet Carrier Subassembly

- 1) Rotate planet gears (14) to check for abnormal noise or roughness in bearings (19) or planet shafts (10). If further inspection or replacement is required, proceed as follows.
- 2) Drive roll pins (23) completely into planet shafts (10).
- 3) Press or drive planet shafts (10) out of carrier (7).
- 4) Remove planet gears (14) and planet washers (12) from the carrier (7).
- 5) If the planet bearings (19) require replacement, press them out of the planet gears (14) and replace with new ones.

- 6) Check primary planet shafts (10) for any abnormal wear, especially ones where bearings needed to be replaced. If any abnormal wear is found, replace planet shafts.
- 7) Remove the roll pins (23) from the planet shafts (10).

## Reassembly

- 1) With planet washers (12) on both sides of the planet gear (14) and with bearings (19) installed, slide gear into the carrier (7). Insert the planet shaft (10) through the carrier, washers, and planet gear.
- 2) Planet shafts (10) should be installed with chamfered end of 1/8 inch hole toward outside diameter of the carrier (7). This will aid in alignment of holes while inserting roll pins (23).
- 3) Drive three roll pins (23) through the carrier holes and into the planet shafts to retain the parts.

## Secondary Planet Carrier Subassembly

As with the primary planet carrier, check for abnormal noise in the planet gears bearings (18) by rotating the planets and listen and feel for any noise or roughness. If further inspection or replacement is required, follow the same procedure as steps 1-6 of the primary planet carrier assembly. Substitute items as indicated: planet gears (15), planet bearings (18), planet shafts (11), washers (13), carrier (8).

The inner bearing cone (17) cannot be removed from the carrier (8), without destroying the bearing. If this needs replacement, please consult the factory.

Proceed with steps 1 through 3 of the primary planet carrier reassembly.

**NOTE 1: See page 6 service bulletin concerning the wear of secondary planet carriers (8)**

**NOTE 2: Retaining ring (26) must be inserted into carrier (8) before it is installed in unit, as described in step number 2 of Unit Assembly.**

## Base Subassembly

**CAUTION: Output shaft is no longer retained. Care should be taken not to injure feet because output shaft can fall out. Care should also be taken not to damage output shaft when shaft is pressed through base.**

- 1) Output shaft removal. Bearing carrier (4) should be set pinion side down, as shown, on a plate or table with output shaft (2) protruding through a hole in table. Press output shaft out bottom of base by applying a load to top end (internal end) of shaft until it passes through inner shaft bearing cone (17).

**NOTE: If reusing old bearing cone, do not damage roller cage by pulling on it.**

- 2) If outer bearing cone (27) needs to be removed a gear puller may be used.
- 3) Remove the shaft seal (36) for inspection or replacement. Lubricate inner lip of new shaft seal (36) and slide the seal onto the shaft (2) until it fits snugly over shaft seal diameter with the open side toward the inside of the auger drive.
- 4) Inspect inner and outer bearing cups (20 & 3) and replace if necessary.

## Reassembly

**NOTE: Press bearing cone onto output shaft by pressing on**

**inner race only. DO NOT press on roller cage or it may damage bearing.**

- 1) If outer bearing cone (27) was removed for replacement, press a new bearing cone (**large end down as shown**) onto the shaft until it seats against the shoulder.
- 2) Clean all foreign material from magnetic oil plug (28). Add a small amount of pipe thread compound to pipe plug before installing back into bearing carrier (4).
- 3) Place the bearing carrier (4) (**output side up, opposite shown**) on the press table.
- 4) Apply a layer of lithium or general purpose bearing grease to surface of outer bearing cup (3). Insert the shaft into the base (**bearing cone down**) and use a soft hammer to install the shaft seal (36) into the base.

**CAUTION: Output shaft is not retained at this point.**

- 5) Invert this assembly so it is standing on the shaft (**on the press table**).

### Kickdown Mechanism

**If you experience problems with your kickdown system, please contact Eskridge for service.**

## Unit Reassembly

Refer to exploded drawing (page 3) and Figure 1 (below)

- 1) When all subassemblies are complete, unit is ready to be assembled. Place lower assembly back on blocks, which were used during the initial disassembly procedures, for remaining unit buildup.

**Caution: Output shaft is not retained at this point.**

- 2) Push retaining ring (26) into center of secondary planet carrier (8).
- 3) Install the secondary planet carrier (8) assembly by rotating it until carrier spline lines up with shaft spline. Begin pressing carrier onto shaft.
- 4) Before secondary carrier is fully seated, install retaining ring (26) onto end of output shaft (2).
- 5) Continue pressing secondary carrier until fully seated. Check retaining ring (26) to be sure it is in the ring groove.
- 6) Place a new o-ring (30) on the bearing carrier (4). Referring to scribe marks for proper orientation, install the secondary ring gear (5) onto the base.
- 7) Place a new o-ring (30) on the secondary ring gear (5) and install the primary ring gear (2). Refer to scribe marks for proper orientation.
- 8) Check to be sure retaining ring (25) is installed on sun gear (16). Slide the sun gear into the secondary planet carrier.
- 9) Install the primary carrier (7) by rotating until spline lines up with sun gear. It may be easier to install the sun gear (12) into the bottom of the primary carrier and then install primary carrier.
- 10) Slide the input gear (13) into the primary planet carrier.
- 11) Install a new o-ring (30) onto the cover (6) and position the cover with the proper orientation to the scribed line.
- 12) Install o-ring (31) onto the hydraulic motor (34).
- 13) Attach hydraulic motor (34) to mounting pad on cover (1) with two

capscrews (32) and lock washers (33). Torque to 130 ft-lbs.

- 14) Install the 1/4 NPT fitting in motor case drain hole. Install JIC tee on previous fitting with outlets horizontal facing left and right.
- 15) Install one of the standard 90 degree elbows in the valve drain port of the motor.
- 16) In the left side, of tee fitting, install the tube from the case drain fittings to the valve drain port fitting on the motor.
- 17) Install the tube which runs from the right side of the tee fitting from above and move the tube nut up to the top end of the tube. Keep the nut in place by wrapping some tape around the tube just under the nut.
- 18) Line up scribe mark on bail assembly (35) with scribe mark on cover (1) and place bail over hydraulic motor (34). Install twelve cap screws (22) with hex flange nuts (24) and torque to 30 ft-lbs.
- 19) Install the fitting (40) into the outlet of the motor (34); use a large crows-foot wrench, if necessary. Install one of the straight fittings into the outlet fitting (40). This fitting must be oriented vertically, pointing up.
- 20) With all fittings in the valve body (38) oriented as shown in Figure 1 and tight, slide the two hex-head cap screws (41) and washers (42) into the valve body (38). Install the valve body (38) into the bail (35).
- 21) Attach the upper end of the tube from step 17 into the long 90 degree elbow; use a crows-foot wrench, if necessary.
- 22) Install one of the 90 degree fittings into the shift port of the motor.
- 23) Install the tube from the lower right fitting of the valve body (38) to the shift port of the motor (34).
- 24) Install the last straight fitting into the pressure sense port on the motor (34).
- 25) Install the tube from the upper right fitting of the valve body (38) to the pressure sense port on the motor (34).
- 26) Install the tube from the upper left fitting on the valve body (38) to the pressure sense port on the motor outlet fitting (40).
- 27) Double check all connections for tightness and be sure valve body attaching cap screws (41) are tight.
- 28) Fill to proper level, as specified on page 2, with EP 80/90 gear oil.

**THE AUGER DRIVE IS NOW READY TO USE.**

**Figure 1 (Kickdown)**

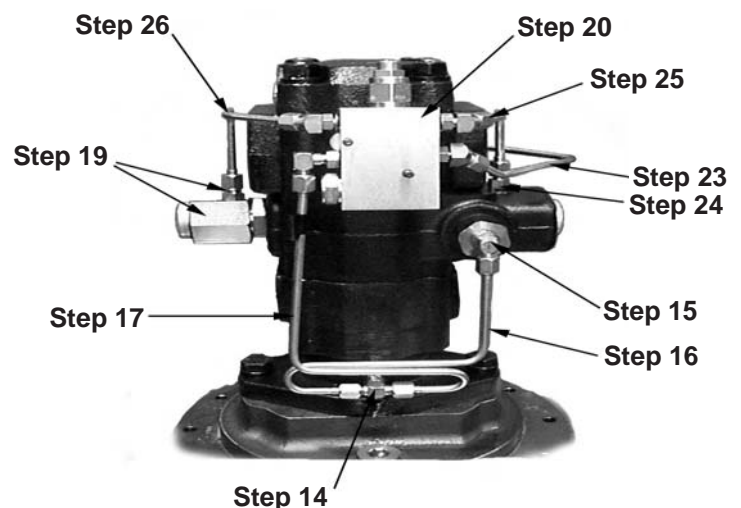



# Service Bulletin #013

Inspection of Secondary Carriers for all model 71/76, 72/77 and 73/78 Planetary Auger Drives

DATE: 06/01/87 (supersedes bulletin dated 01/14/86)

When repairing, updating or inspecting an auger drive, the secondary carrier should be inspected for possible wear around the spline where it contacts the shaft retaining ring. Under heavy use and / or in rocky regions, continual impacting of the retaining ring against the carrier may cause wear in this area. If it wears to a beveled shape, high loading in the pullout direction could cause the shaft retaining ring to dislodge from its groove allowing the hex shaft to pull out of the unit.

If when inspected, the carrier is found to be worn to a bevel shape, the carrier should be replaced with carrier part number 71-004-0073. Units with serial numbers prior to 4900 should also have the hex output shaft replaced with the current production revision, part number 71-004-0513.

