

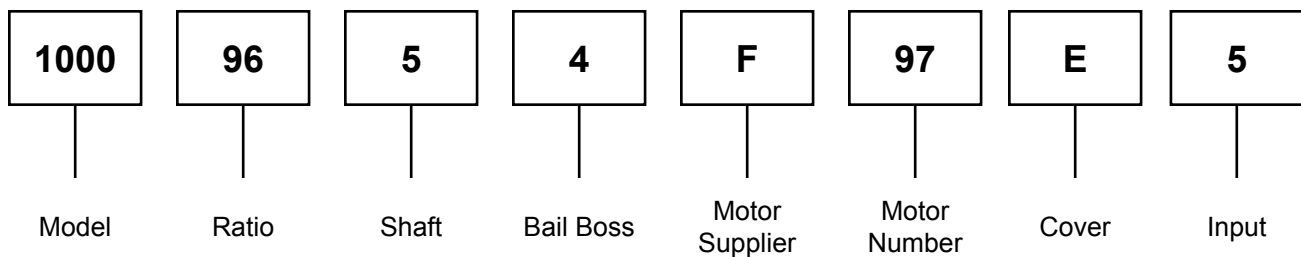

SERVICE MANUAL 1000 SERIES DIGGER MODELS



Example Part Number



THIS SERVICE MANUAL IS EFFECTIVE:
S/N: 89000 TO CURRENT
DATE: 1-2010 TO CURRENT
VERSION: SMD100096-54F97E5

NOTE: Individual customer specifications (spindle mounting, sprocket pilot, brake assembly, etc.) may vary from exploded drawing and standard part numbers shown. If applicable, refer to customer drawing for details.



Exploded View Drawing 100096-54F97E5

MODEL 100096-54F97E5 DIGGER

ITEM	QTY	DESCRIPTION	PART NO.
1	1	BASE-"F" FLANGLESS	60-004-3014
2	1	OUTPUT SHAFT: 5-1/4" SQUARE	60-004-4222L
3	1	COVER (4 BOLT "E")	60-004-1564
4	1	INPUT GEAR	60-004-1462
5	(1)	CARRIER ASSEMBLY- PRIMARY	60-005-2043
5A	1	CARRIER	60-004-1024
5B	3	CLUSTER GEAR	60-004-1182
5C	3	PLANET SHAFT	60-004-1272
5D	6	BEARING (CAGE & ROLLER)	01-105-0510
5E	6	THRUST WASHER	60-004-1881
5F	3	ROLL PIN	01-153-0150
6	1	SUN GEAR	60-004-1222
7	(1)	CARRIER ASSEMBLY- SECONDARY	60-005-2083
7A	1	CARRIER	60-004-1044
7B	3	PLANET GEAR	60-004-1232
7C	3	PLANET SHAFT	60-004-1262
7D	6	BEARING CONE	01-102-0210
7E	6	BEARING CUP	01-103-0210
7F	3	RETAINING RING	01-160-0490
7G	6	RETAINING RING	01-160-0500
7H	6	WASHER	60-004-1291
7J	6	SHIM	60-004-1321
7K	3	ROLL PIN	01-153-0150
7L	1	PLATE - SEC CARRIER RETAINER	60-004-1352
8	RING GEARS & SPACER		
8A	1	RING GEAR - PRIMARY	60-004-1213
8B	1	RING GEAR - SECONDARY	60-004-1243
8C	1	RING SPACER	60-004-1253
10	THRUST WASHERS & BEARINGS		
10A	2	BEARING THRUST RACE - PRIMARY	01-112-0350
10B	1	BEARING - PRIMARY THRUST	01-112-0340
10C	1	BEARING THRUST RACE - INPUT	01-112-0060
11	SEALS & O-RINGS		
11A	1	O-RING	01-402-0670
11B	3	O-RING	01-402-0660
11C	1	OUTPUT SHAFT SEAL	01-405-0810
12	OUTPUT SHAFT BEARINGS		
12A	1	OUTER CONE	01-102-0190
12B	1	OUTER CUP	01-103-0190
12C	1	INNER CONE	01-102-0220
12D	1	INNER CUP	01-103-0220
13	HARDWARE		
13A	6	SHCS (3/8-16 X 1) GR8	01-150-1110
13B	12	SHCS (1/2-13 X 1-1/2) GR8	01-150-0570
13C	3	FHS C.S. (3/8-24 X 1)GR8	01-150-1590
13D	20	HHCS (3/4-10 X 11.5) GR8	01-150-1720
13E	20	HARDWASHER (3/4 X 1.25 OD)	01-166-0350
13F	4	HHCS (3/4-10 X 1.75) GR8	01-150-1890
13G	4	LOCKWASHER (3/4 MED)	01-166-0360
14	6	PIPE PLUG (3/4 NPT MAGNETIC)	01-207-0100
15	MISCELLANEOUS		
15A	1	SEAL CARRIER	60-004-1922
15B	1	BAIL ASSEMBLY	60-005-1622
15C	*	SHIM	60-004-1311
15D	1	LOCK RING	60-004-1472
15E	1	SPLIT RING (L-SEGMENT)	60-004-1482
15F	1	RETAINING RING	01-160-0510
16	1	MOTOR	01-304-0970

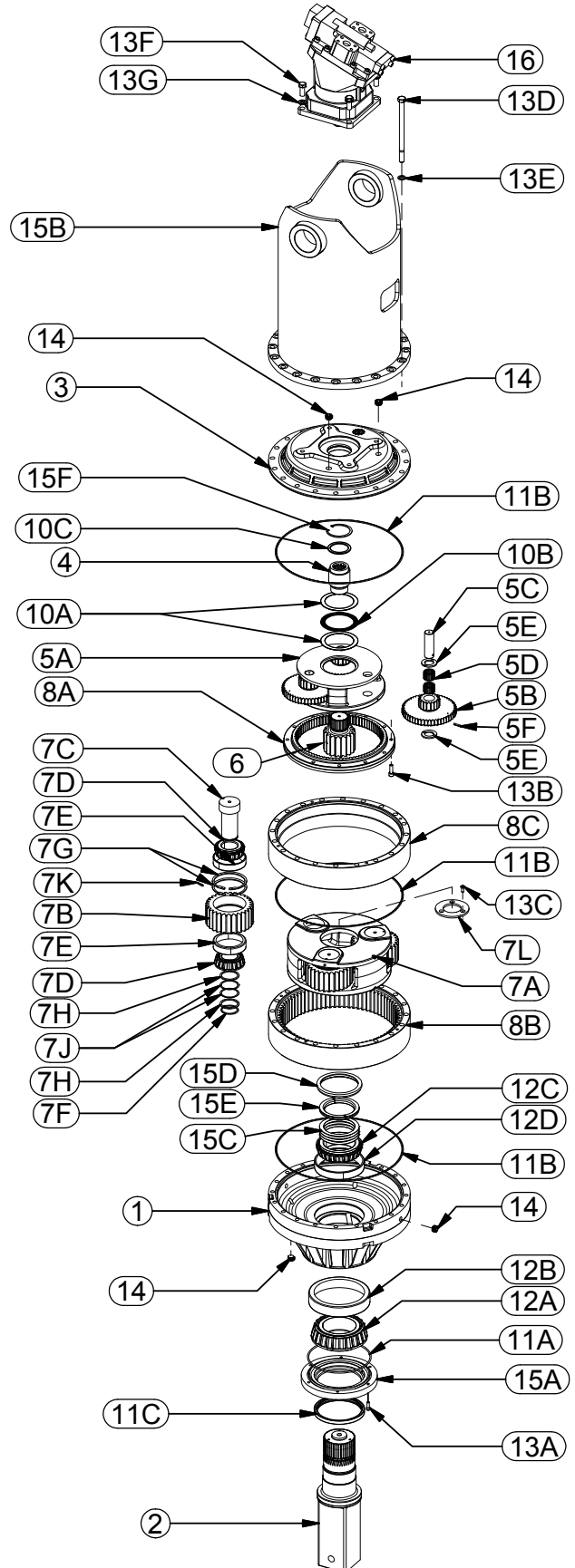

X100096-54F97E5aa 05-12-10 ECN- HWP

LUBRICATION & MAINTENANCE

Using the chart below, determine an appropriate lubricant viscosity. Use only EP (extreme pressure) or API GL-5 designated lubricants. Change the lubricant after the first 50 hours of operation and at 500 hour intervals thereafter. The auger drive should be partially disassembled to inspect gears and bearings at 1000 hour intervals.



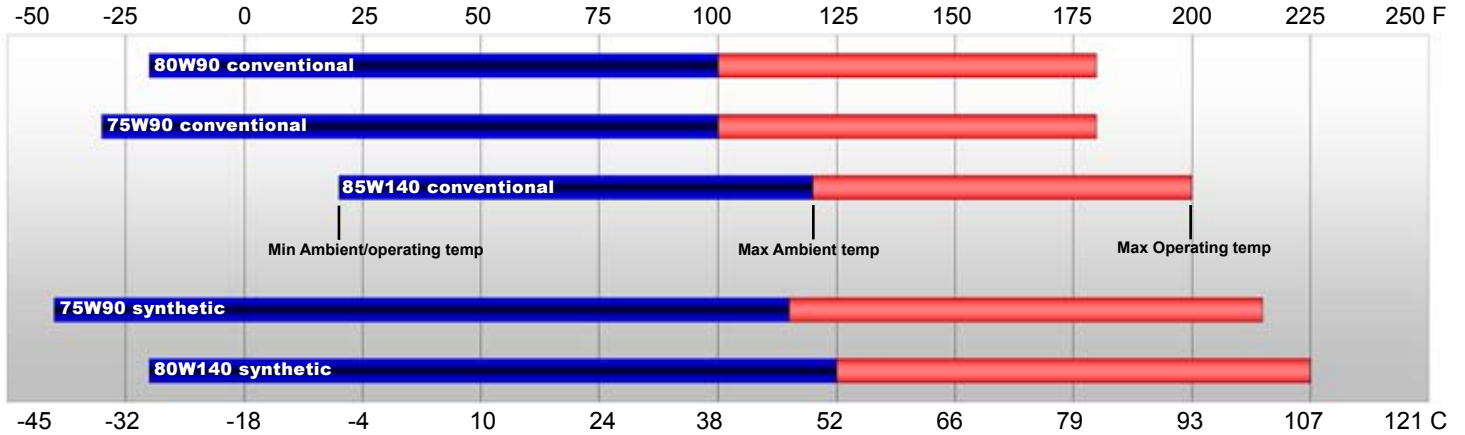

Recommended ambient and operating temperatures for conventional and synthetic gear lubricants



Note: Ambient temperature is the air temperature measured in the immediate vicinity of the gearbox. A gearbox exposed to the direct rays of the sun or other radiant heat sources will operate at higher temperatures and therefore must be given special consideration. The max operating temp must not be exceeded under any circumstances, regardless of ambient temperature.

If your unit was specified "shaft up" or with a "-Z" option, a grease zerk was provided in the base housing. For shaft-up operation, the output bearing will not run in oil and must be grease lubricated. Use a lithium based or general purpose bearing grease sparingly every 50 operating hours or at regular maintenance intervals. Over-greasing the output bearing should be avoided as it tends to fill the housing with grease and thicken the oil

ESKRIDGE MODEL D1000 OIL CAPACITIES

Operating Position	Oil Capacity			Oil Level
	Single stage	Double stage	Triple stage	
 Horizontal Shaft	-	-	-	To horizontal centerline of auger drive 
 Vertical Shaft (Pinion Down)	-	8.25 gal	-	To midway on upper/primary gear set 



WARNING: While working on this equipment, use safe lifting procedures, wear adequate clothing and wear hearing, eye and respiratory protection.

ESKRIDGE PART NUMBER INTERPRETATION

Note: All non custom Eskridge Geardrives are issued a descriptive part number which includes information regarding the Model, means of shaft retention, base style, shaft style, input mounting, input shaft size, overall ratio and various available options. For a detailed breakdown of this information, please refer to Eskridge product specification sheets found at: <http://www.eskridgeinc.com/diggers/diggerprodspecs.html>

Unit Disassembly Procedure

- 1) Scribe a diagonal line across the outside of the unit from the bail (15B) to the base (1) before disassembly to aid in the proper positioning of pieces during reassembly.
- 2) Remove magnetic drain plugs (14) and drain oil from unit. The oil will drain out faster and more completely if warm.
- 3) Remove the twenty hex-head capscrews (13D) and flat washers (13E).
- 4) Separate bail (15B) from ring gear adapter (15A) and remove from digger assembly.
- 5) Install two hex-head capscrews (13D) into cover (3) to retain gearbox assembly together while removing motor fasteners.
- 6) Remove motor (16) from cover (3) and remove temporary fasteners (13D).
- 7) Remove cover (3), thrust bearings (10A, 10B & 10C), remove input gear (4). Inspect o-ring (11B); discard if damaged or deformed.
- 8) Lift Stage I planet carrier assembly (5) out of the unit. Remove ring gear spacer (8C) and inspect o-ring (11B); discard if damaged or deformed.
- 9) Remove Stage II sun gear (6) from secondary carrier assembly (7).
- 10) Remove the three 3/8-24 flat head capscrews (13C) securing the carrier retaining plate (7L) to the output shaft (2).
- 11) Remove remaining ring gear (8B) and Stage II carrier assembly (7). Inspect gear to gear and gear to base o-ring(s) (11B), discard and replace any damaged or deformed o-rings.
- 12) The unit is now separated into subassemblies. The area(s) requiring repair should be identified by thorough inspection of the individual components after they have been cleaned and dried.

Disassembly

- 1) Rotate planet gears (5B) to check for abnormal noise or roughness in bearings (5D) or planet shafts (5C). If further inspection or replacement is required, proceed as follows.
- 2) Drive roll pins (5F) completely into the planet shafts (5C).
- 3) Press or drive planet shafts (5C) out of carrier (5A).
- 4) Remove planet gears (5B) and thrust washers (5E) from the carrier (5A).
- 5) Inspect the planet gear (5B) bearing bore, planet shaft (5C) and rollers (5D). Check for spalling, bruising or other damage.
- 6) Replace any parts where abnormal wear is found.
- 7) Use 3/16 inch pin punch to remove roll pins (5F) from planet shafts (5C).

NOTE: If either the rollers or the planet shafts (pins) are damaged, both components should be replaced.

Reassembly

- 1) To install rollers in planet gear bore:
 - a) Set planet washer (5E) on work table, place planet gear (5B) onto washer and insert bearings (5D) into planet bore.
 - b) Place planet washer (5E) onto top of planet gear then slide the gear into carrier (5A). (Oriented as shown.)
- 2) Planet shafts (5C) should be installed with chamfered end of 3/16 inch hole toward outside diameter of the carrier (5A). This will aid in alignment of holes while inserting roll pins (5F).
- 3) Drive a roll pin (5F) through the carrier hole and into the planet shaft to retain the parts. Repeat for other planet gears.

Stage I Carrier Subassembly

(Items 5A, 5B, 5C, 5D, 5E, & 5F)

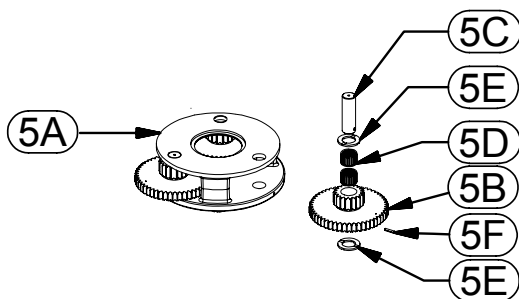

Stage II Carrier Subassembly

(Items 7A, 7B, 7C, 7D, 7E, 7F, 7G, 7H, 7J & 7K)

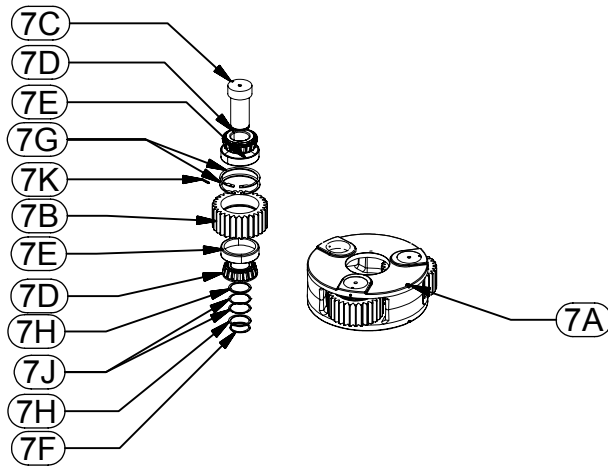

Disassembly

- 1) Rotate planet gears (7B) to check for abnormal noise or roughness in bearings (7D, 7E). If further inspection or replacement is required, proceed as follows.
- 2) Removing retaining ring (7F), washer (7H) and shims (7J) from planet shaft (7D).
- 3) Press planet shafts (7C) out of carrier (7A).
- 4) Remove planet gears (7B) and washer (7H) from carrier.
- 5) Inspect the planet gear (7B), bearing cone (7D), bearing cup (7E) and planet shaft (7C). Check for spalling, bruising or other damage. Replace components as necessary; bearing need to be replaced as a cup and cone set.
- 6) Replace any parts where abnormal wear is found.

Reassembly

- 1) Rebuild Stage II planet carrier assembly in reverse order using any needed new parts.
- 2) Install bearing cones (7D) into planet gear bearing cups (7E). Place washer (7H) onto interior carrier spot faced surface.
- 3) Insert planet gear assembly into carrier (7A). Slide planet shaft (7C) into carrier planet assembly and align planet pin notch with roll pin in carrier.
- 4) Place shims (7J) and washer (7H) onto planet shaft. Install retaining ring (7F). Rotate planet gears by hand to test bearing preload. Correct bearing preload on the planet gears requires 50-75 in-lbs rotating torque. If gear doesn't rotate remove a shim and test again until a smooth loaded rotation is developed. Repeat for remaining planet gears.

Base Subassembly

(Items 1, 2, 11C, 12A, 12B, 12C, 12D, 14, 15A, 15C, 15D, & 15E)

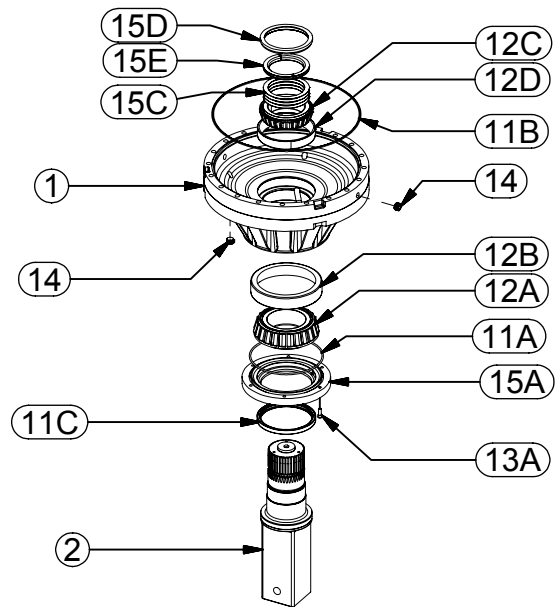

Disassembly

- 1) Remove the seal carrier retaining screws (13A) and seal carrier (15A) from unit. Inspect seal (11C) and o-ring (11A) for signs of wear or damage and replace as necessary.
- 2) Remove the lock ring (15D) using a heel bar or puller; if using a heel bar, be sure not to pry against the cage of the inner output shaft bearing (12C). Remove the split ring segments (15E) and shims (15C).

Caution: Since the output shaft is no longer retained, care should be taken to avoid personal injury. Care should also be taken not to damage it when it is pressed through base.

- 3) Base (1) should be set pinion side down, as shown, on a plate or table. Press output shaft through the bottom of base by applying a load to top end (internal end) of shaft until it passes through inner shaft bearing cone (12C).

Note: Removing the shaft from the base assembly damages the shaft seal and the seal will need to be replaced.

- 4) A gear puller may be used to remove the outer bearing cone (12A) from the shaft (2). If reusing old bearing cone, do not pull on or damage roller cage.
- 5) Inspect inner and outer bearing cups (12A, 12B, 12C & 12D). If cups are damaged, drive them out using a brass drift and utilizing the bearing knock-out notches in the base (1)

Reassembly

- 1) Clean all foreign material from magnetic oil plug (14) located on the side of the base (1).
- 2) Place base (1) (output side up, opposite shown) on the table.
- 3) Apply a layer of lithium or general purpose bearing grease to the roller contact surface of outer bearing cup (12A).
- 4) Press outer bearing cone (12B) (large end down as shown) onto the shaft until it seats against the shoulder.

Note: Press bearing cone onto output shaft by pressing on inner race only. DO NOT press on roller cage, as it may damage bearing.

- 5) Place the shaft (2) with the bearing (12A) into the base (1).
- 6) Flip this assembly, resting the base (1) on the end of the output shaft (2).
- 7) Apply a layer of lithium or general purpose bearing grease to the roller contact surface of the inner cup (12D). Press the inner bearing cone (12C) (large end up as shown) onto the shaft (2) until it is seated against inner bearing cup (12D).
- 8) Without the shaft seal (11C) installed, the preload may result in a rolling torque that varies between 50 to 300 in-lb. The bearing preload should be tailored to your application; a low-speed application may require a high pre-load, high-speed applications usually benefit from low pre-load. Adding shims (15C) will increase the pre-load on the bearing set. Determine your pre-load requirement and install shims to obtain this pre-load. Install the Load-N-Lock™ segments (15E) over the shims (15C) and into the groove in the shaft (2). Finally, install the lock ring (15D) over the segments (15E).
- 9) Install o-ring (11A) onto seal carrier (15A). Lubricate inner lip of new shaft seal (11B) and slide seal carrier assembly onto the shaft (2). Install seal carrier fasteners (13A) and torque to 30 ft-lbs.

All subassembly service or repairs should be complete at this time. Continue to Unit Assembly to complete unit buildup.

Unit Assembly

- 1) When all subassemblies are complete, the unit is ready to be assembled.
- 2) Install the Stage II carrier assembly onto the output shaft; align the splines of the carrier (7A) with the splines of the shaft (2) and slide the carrier onto the shaft.
- 3) Install carrier retaining plate (7L) & secure using 3/8-24 Flat-head capscrews (13C).
- 4) Lubricate o-ring (11B) and install on the pilot of the Stage II ring gear (8B).

Caution: Hold ring gear by outside or use lifting device to prevent injury.

- 5) Install Stage II sun gear (6) into Stage II carrier assembly.
- 6) Align gear teeth of ring gear (8B) with the gear teeth of the planet gears (7B) and place on base. Align mounting holes of ring gear with holes in base. Using the scribed line made during disassembly for reference.
- 7) Place Stage I carrier (5A) onto Stage II sun gear (6).
- 8) Lubricate o-ring (11B) and install on the pilot of the Stage I ring gear spacer (8B). Install spacer.
- 9) Compound primary timing instructions:
 - a) The planet gears will now need to be timed. Refer to the diagram. The planet gears each have a timing mark, usually a round punch locate timing marks on planet gear (5B).

PRIMARY CARRIER TIMING DIAGRAM

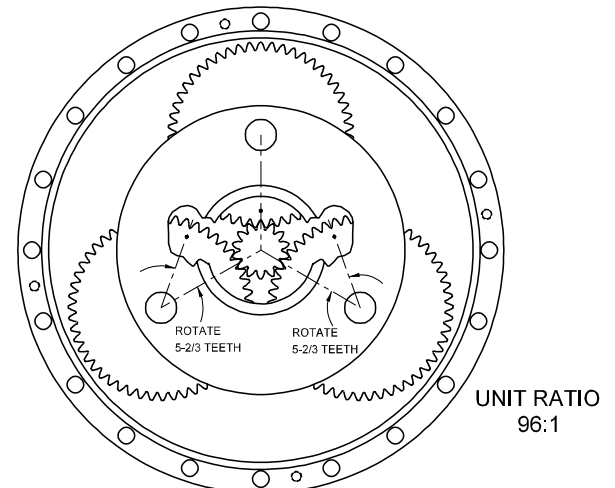

- b) As seen from above, start with the top planet gear and position it's timing mark pointing straight down. Next, rotate the lower left planet gear counterclockwise as indicated in the timing diagram. Then rotate the lower right planet gear clockwise as indicated.
 - c) Set the input gear (4) and the input thrust race (10C) into the center of the primary planet carrier assembly.
 - d) If compound primary ring gear (8A) was not removed during disassembly, then skip to step 9. Otherwise, bolt to the inside of the cover (3) with twelve bolts (13B). Use a removable thread locking compound on the threads of the bolts. Tighten to 110 ft.-lbs. dry or 80 ft.-lbs. lubricated.
- 9) Install thrust washer (10A) onto primary carrier then install thrust bearing (10B) and thrust washer (10A).
 - 10) Lubricate o-ring (11B) and install on the pilot of the cover (3).
 - 11) Noting the scribed line made during disassembly, install the cover (3). Install 2 fasteners (13D) to retain unit together.
 - 12) Ensure the unit spins freely by using a splined shaft to drive the input gear (4). If unit does not rotate freely for one revolution remove cover and verify primary planet gearing is timed correctly.
 - 13) Install motor (16) onto cover (3) and align motor shifting mechanism with bail relief hole. Install motor fasteners.
 - 14) Remove two temporarily fasteners installed in step 11. Place bail (15B) onto assembly and aligning holes in bail and cover using scribed line made during disassembly as a reference. Install and torque the 20 3/4-10 hex head capscrews (13D) with flat washers (13E). **The torque for the capscrews is 380 ft-lbs dry, 280 ft-lbs if fasteners are lubricated.**
 - 15) Fill the unit to the proper level, as specified, with GL5 EP 80/90 gear oil after it is sealed with the motor.

The digger is now ready to use.