

SINGLE PIVOT HOOK HOIST



Tel: 800.285.0666 | sales@wastequip.com | www.galbreathproducts.com



» **9,000 to 30,000 lb. capacity**

» **Container lengths from 6' to 20'**

Galbreath single pivot hook hoists feature a universal fit for nearly any chassis. The simple design of the single pivot hook hoist means fewer moving parts and less maintenance.

**SINGLE
PIVOT
SERIES**

STANDARD FEATURES

Ease of Operation

- Centered cab-mount Power Tower
- Plug n' Play wiring system
- Roller stools
- Standard inside and outside air controls

Safety

- Heavy-duty safety props
- Back-up alarm and hoist-up alarm with signal light on dash
- Stationary rear hold-downs
- Optional hoist-up speed-limiting parameters

Quality

- Stringent, multi-year product testing, engineering, solid modeling, and stress analysis testing ensure maximum product quality
- Customized engineering layouts are based on customers' chassis to ensure compatibility

Durability

- 3 micron filtration system with dual viscosity oil
- Two-part epoxy primer and paint*
- Hoist frames are huck-bolted to chassis*
- Steel oil reservoir is filter cart-ready
- Bumper with recessed LED lighting
- Direct mount pump
- Rubber mounted sealed lights
- Pivot joints feature hardened steel bushings and grease fittings
- Outboard supported upper lift shaft
- Lifetime warranty on frame and two-year warranty on hydraulics

All Galbreath products are designed to be compliant with ANSI standard container requirements.

AVAILABLE OPTIONS

- Lift axles
- Tires and rims
- Hydraulic/wet kits
- Air compressors for non-air chassis
- Additional lighting
- Bumpers, pintle hooks and reese hitches
- Various fender selections
- Toolboxes

SPECIFICATIONS

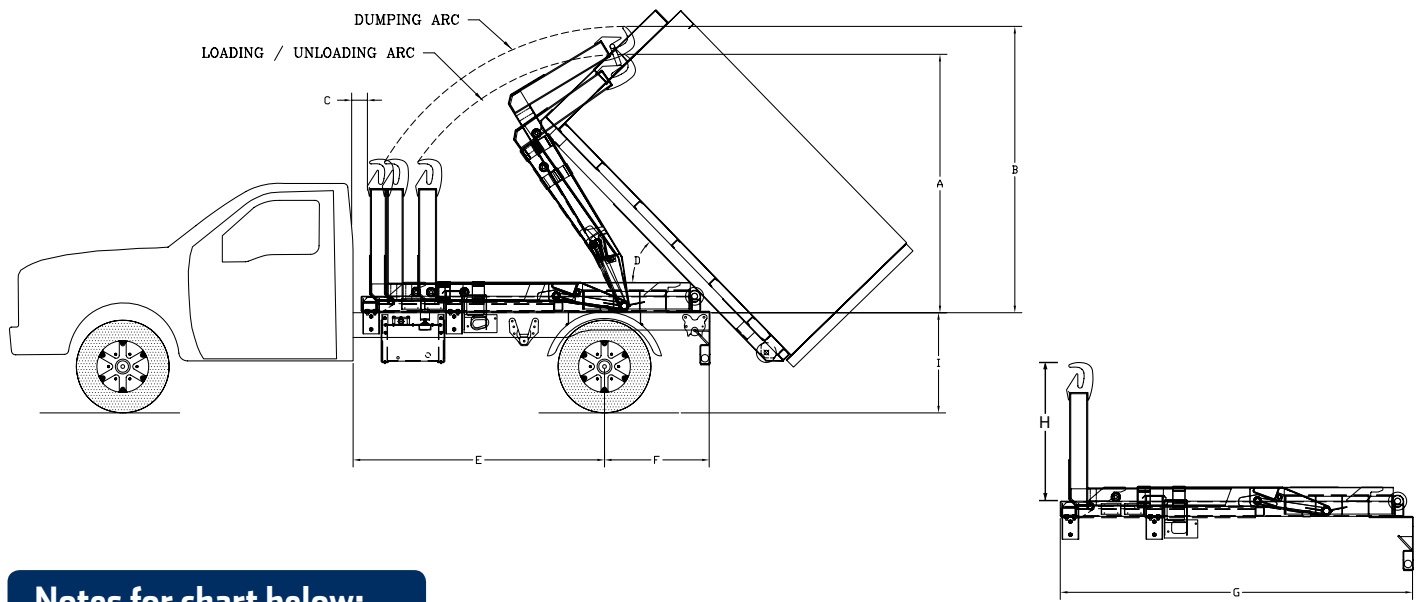

Notes for chart below:

- 1 Factory-tested with recommended container length and water level load.
- 2 When recommending container lengths, weight distribution, dump angle and overhang are factors.
- 3 Noted container lengths will overhang between 24" and under 48." Consult sales representative for additional details.

- 4 Total maximum height will depend on container. Consult engineering for clearance.
- 5 Consult engineering for best configuration.

Notes: ¹U20- HK 35-1/2 HK HT- 10'-44" / 12'-57" / 14'-44" / 12'-50" / 14'-42" / 16'-36"
²U20- HK 54' HK HT- 12'-50" / 14'-42" / 16'-35"

| | U9-HK-84 | U9-HK-120 | U13-HK-120 | U13-HK-132 / 144 |
|---|---------------------------|----------------------------|--|-------------------|
| Recommended container length | 6'-10' | 9'-12' | 10'-14' / 12'-16' | 12'-16' |
| Rated capacity | 9,000 lbs. | 9,000 lbs | 13,000 lbs | 13,000 lbs |
| Cycle times (seconds) | | | | |
| Extending dump | 26.37 (at 17.5 gpm) | 26.37 (at 17.5 gpm) | 30 (at 37.5 gpm) | 30 (at 37.5 gpm) |
| Retracting dump | 16.88 (at 17.5 gpm) | 16.88 (at 17.5 gpm) | 19 (at 37.5 gpm) | 19 (at 37.5 gpm) |
| Extending jib | 4 (at 17.5 gpm) | 4 (at 17.5 gpm) | 4 (at 37.5 gpm) | 4 (at 37.5 gpm) |
| Retracting jib | 2 (at 17.5 gpm) | 2 (at 17.5 gpm) | 2 (at 37.5 gpm) | 2 (at 37.5 gpm) |
| A - Max. hook height above truck frame loading/unloading | 86-5/16" | 85-1/16" | 91-7/8" | 91-7/8" |
| B - Max. hook height above truck frame dumping | 95-11/16" | 104-5/16" | 120-1/4" | 120-1/4" |
| C - Cab to hoist | 5" | 8" | 3-1/2" | 3-1/2" |
| D - Dump angle | 6'-60° / 8'-74° / 10'-62° | 9'-64° / 10'-57° / 12'-46° | 10'-56° / 12'-56° / 14'-49° 12'-59° / 14'-48° / 16'-40° | 42° |
| E - Cab to axle | 84" | 120" | 120" | 132" / 144" |
| F - After frame | 35" | 35" | 38-1/2" / 62-1/2" | 50-1/2" / 38-1/2" |
| G - Hoist length | 116-1/4" | 144-13/16" | 155" | 179" |
| H - Hook height | 36" | 36" | 36" | 36" |
| I - Frame height | 33-1/2" or less | 33-1/2" or less | 44-1/4" or less | 44-1/4" or less |
| Lift cylinders | 5" x 3" x 45 | 5" x 3" x 45 | 5" x 3" x 52 | 5" x 3" x 52 |
| Jib cylinder | 3" x 2" x 16-1/4 | 3" x 2" x 16-1/4 | 3" x 2" x 37 | 3" x 2" x 37 |
| Approx. weight | 2,060 lbs. | 2,460 lbs | 2,758 lbs | 2,758 lbs |

| FEATURES | | HYDRAULIC SYSTEM | |
|-----------------------------|---|---------------------------|--|
| Cross members | Structural tubing 62,000 lbs. min. tensile A500 Grade C | Gear pump | 17.5 gpm at 1,500 RPM direct mount |
| Main frame | Structural tubing 62,000 lbs. min. tensile A500 Grade C | Hydraulic valve | Outside control levers with proportional controls with air-operated steel reservoir with 10 micron air |
| Jib frame | A514 T-1 and structural tubing A500 Grade C | Steel reservoir | 10 micron air breather, 3 micron in-tank return filter and filler, sight gauge with temperature gauge |
| Pivot tube | A514 T-1 and structural tubing A500 Grade C | Lifting cylinders | 5" 4,000 psi lifting cylinders with built-in counterbalance valves |
| Pickup hook | A514- T-1 100,000 psi min. yield | Jib cylinder | 3" 4,000 psi jib cylinder with built-in counterbalance valve |
| Lift cylinder shafts | 1-1/2" solid (64,000 lb. tensile min.) | Operating pressure | 3,800 psi |
| Hinge shaft | 2" solid (64,000 lb. tensile) | Jib bearing | A514T-1 100,000 psi minimum yield bar |
| Jib bearing | A514T-1 100,000 psi minimum yield bar | | |

| | U20-HK-120 | U20-HK-132 / 144 | U30-HK-138 | U30-HK-156 |
|---|--|-----------------------------|-------------------|-------------------|
| Recommended container length | 10'-14' / 12'- 16' | 12'-16' | 12'-16' / 14'-18' | 14'-18' / 16'-20' |
| Rated capacity | 20,000 lbs | 20,000 lbs | 30,000 lbs | 30,000 lbs |
| Cycle times (seconds) | | | | |
| Extending dump | 30 (at 37.5 gpm) | 30 (at 37.5 gpm) | 31 (at 37.5 gpm) | 31 (at 37.5 gpm) |
| Retracting dump | 19 (at 37.5 gpm) | 19 (at 37.5 gpm) | 20 (at 37.5 gpm) | 20 (at 37.5 gpm) |
| Extending jib | 4 (at 37.5 gpm) | 4 (at 37.5 gpm) | 4 (at 37.5 gpm) | 4 (at 37.5 gpm) |
| Retracting jib | 2 (at 37.5 gpm) | 2 (at 37.5 gpm) | 3 (at 37.5 gpm) | 3 (at 37.5 gpm) |
| A - Max. hook height above truck frame loading/unloading | 106" | 106" | 119-3/16" | 119-3/16" |
| B - Max. hook height above truck frame dumping | 131-5/8" | 131-5/8" | 156-3/16" | 156-3/16" |
| C - Cab to hoist | 2-1/4" | 2-1/4" | 3-1/2" | 3-1/2" |
| D - Dump angle | 10'-56° / 12'-56° / 14'-42° 12'-49° / 14'-42° / 16'-35° | 12'-50° / 14'-42° / 16'-35° | 12'- / 14'- | 14'- / 16' |
| E - Cab to axle | 120" | 132" / 144" | 138" | 156" |
| F - After frame | 38-1/2" / 62-1/2" | 50-1/2" / 38-1/2" | 44-3/4' / 68-3/4" | 50-3/4" |
| G - Hoist length | 155-5/8" | 179-5/16" | 179-3/16" | 203-3/8" |
| H - Hook height | 54" | 54" | 54" | 54" |
| I - Frame height | 51-3/4" or less | 51-3/4" or less | 50-1/4" or less | 50-1/4" or less |
| Lift cylinders | 5" x 3" x 52 | 5" x 3" x 52 | 5" x 3" x 52 | 5" x 3" x 52 |
| Jib cylinder | 3" x 2" x 37 | 3" x 2" x 37 | 3" x 2" x 37 | 3" x 2" x 37 |
| Approx. weight | 3,719 lbs | 3,719 lbs | 3,719 lbs | 3,719 lbs |

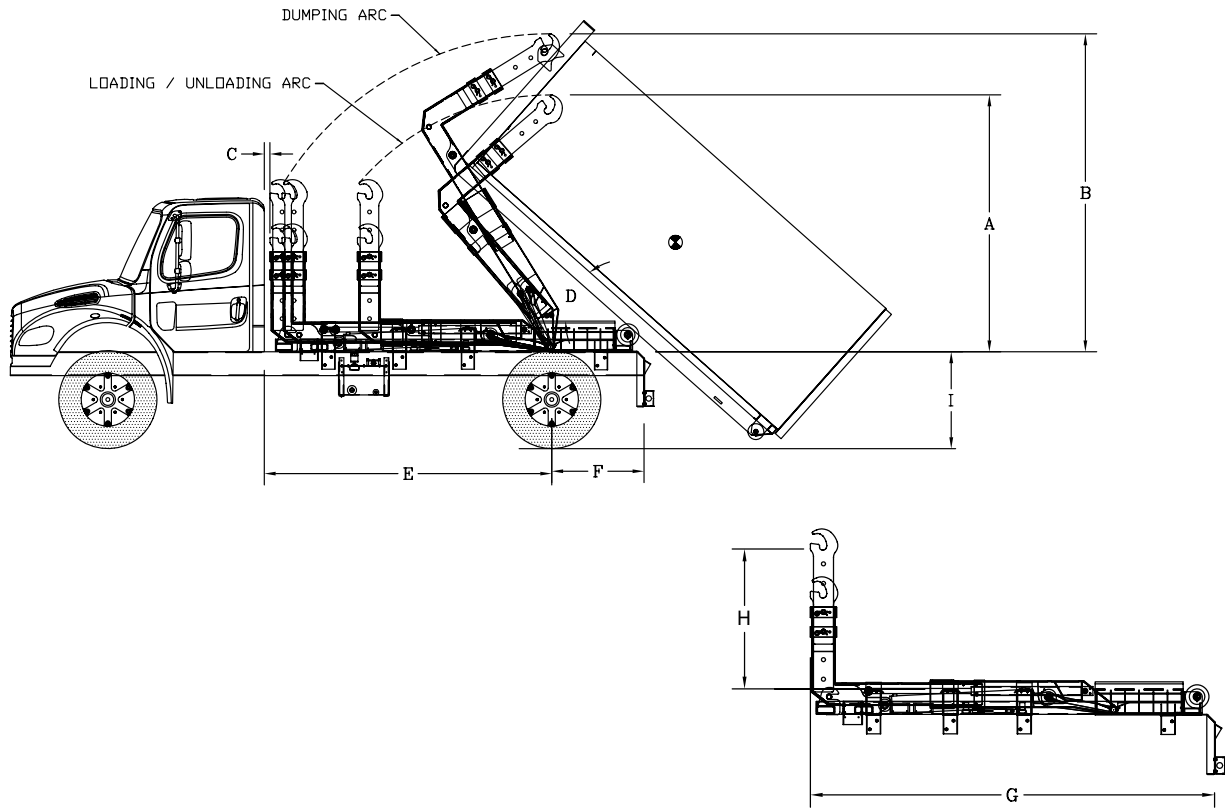

| | U30-HK-176 | U20/13-HK-120 | U20/13-HK-132 | U20/13-HK-144 |
|---|------------------|--|---|--|
| Recommended container length | 16'-20' | 10'- 14' / 12'-16' | 12'-16' | 12'-16' |
| Rated capacity | 30,000 lbs | 13,000 lbs / 20,000 lbs | 13,000 lbs / 20,000 lbs | 13,000 lbs / 20,000 lbs |
| Cycle times (seconds) | | | | |
| Extending dump | 31 (at 37.5 gpm) | 14 (at 37.5 gpm) | 14 (at 37.5 gpm) | 14 (at 37.5 gpm) |
| Retracting dump | 20 (at 37.5 gpm) | 9 (at 37.5 gpm) | 9 (at 37.5 gpm) | 9 (at 37.5 gpm) |
| Extending jib | 4 (at 37.5 gpm) | 2 (at 37.5 gpm) | 2 (at 37.5 gpm) | 2 (at 37.5 gpm) |
| Retracting jib | 3 (at 37.5 gpm) | 31 (at 37.5 gpm) | 31 (at 37.5 gpm) | 31 (at 37.5 gpm) |
| A - Max. hook height above truck frame loading/unloading | 119-3/16" | 107" / 96" | 107" / 96" | 107" / 96" |
| B - Max. hook height above truck frame dumping | 156-3/16" | 132" / 124" | 132" / 124" | 132" / 124" |
| C - Cab to hoist | 3-1/2" | 2-1/4" | 2-1/4" | 2-1/4" |
| D - Dump angle | 38° | (U13- HK 35-1/2 HK HT) 10'-56° / 12'-68° / 14'-59-1/2° 12'-61° / 14'-51° / 16'-41° * See Note 1 | (U13- HK 35 1/2 HK HT) 12'-60° / 14'-50° / 16'-41° * See Note 2 | (U13- HK 35 1/2 HK HT) 12'-60° / 14'-50° / 16'-41° *See Note 2 |
| E - Cab to axle | 176" | 120" | 132" | 144" |
| F - After frame | 54-3/4" | 38-1/2" / 63-1/2" | 50-1/2" | 38-1/2" |
| G - Hoist length | 227-3/8" | 156" | 180" | 180" |
| H - Hook height | 54" | 54" / 36" | 54" / 36" | 54" / 36" |
| I - Frame height | 50-1/4" or less | 40-1/2" or less | 40-1/2" or less | 40-1/2" or less |
| Lift cylinders | 5" x 3" x 52 | 5" x 3" x 52 | 5" x 3" x 52 | 5" x 3" x 52 |
| Jib cylinder | 3" x 2" x 37 | 3" x 2" x 37 | 3" x 2" x 37 | 3" x 2" x 37 |
| Approx. weight | 3,719 lbs | 3,719 lbs | 3,719 lbs | 3,719 lbs |

GALBREATH QUALITY

Standard Features



FRONT STOP

The front and rear stops help lock the container for forward and backward motion



REAR STOP



"Plug n' Play" wiring system eliminates crossed wires, loose connections, corrosion and splices; allows for easy light replacement



OIL RESERVOIR

Oil reservoir is filter cart ready, reducing maintenance costs



Hoist frames are huck bolted to chassis, providing unmatched strength and durability (factory mount only)



CONTAINER HOOKS

Container jib hook meets DOT requirements for front container securement



TOOL BOX

The optional tool box comes in 20" x 16" x 24" long, 48" long steel and 36" long poly box



REAR ROLLER

Optional rear rollers aid in loading and unloading the container



REESE RECEIVER / PINTLE HOOK

Optional 2" receiver 3,000 lb. vertical load, 16,000 lb. gross trailer weight with LED light bumper. Pintle hook option comes with gladhands. The truck must have a trailer package at the rear (20k vertical and 100k tow rating)

TRUCK SPECIFICATIONS BY MODEL

ALL MODELS EXCEPT U9-HK-84 & U9-HK-120

- Front axle: 8,000 lbs. (min.) capacity with power steering
- Rear axle: 18,000 lbs. (min.) capacity
- 50,000 psi or more chassis frames
- Minimum section modulus = 15.5 in.³

MODELS U9-HK-84 & U9-HK-120 ONLY

- Front axle: 6,000 lbs. (min.) capacity with power steering
- Rear axle: 12,000 lbs. (min.) capacity
- 50,000 psi or more chassis frames
- Minimum section modulus = 10.7 in.³

CONTAINER REQUIREMENTS

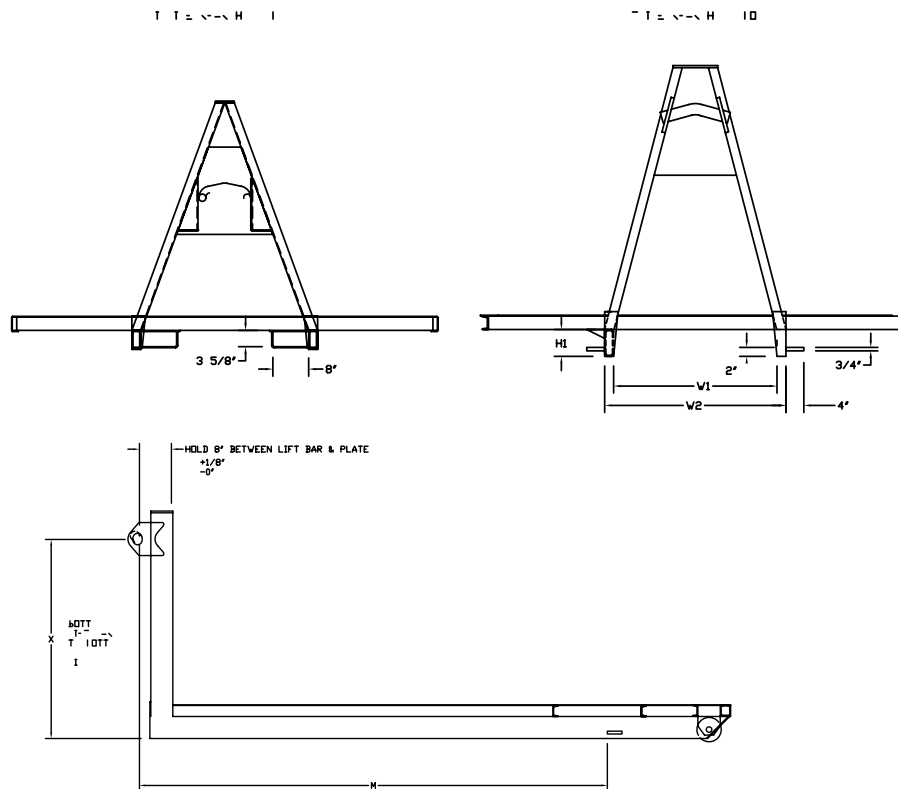

| Compatible hoist model | Lift bar diameter | Hook height | Distance from back of lift bar to front of rear hold down | Rear hold downs (inside/outside) | Inside width of long sills (min.) | Outside width of long sills (max.) | Long sill height (min.) |
|--|-------------------|---------------|---|----------------------------------|-----------------------------------|------------------------------------|-------------------------|
| | | X dim. | M dim. | | W1 dim. | W2 dim. | H1 dim. |
| U9-HK | 1-1/2" | 35-1/2" - 36" | 95-1/4" | Inside | 37-1/2" | 41-1/2" | 4-1/4" |
| U13-HK U20/13 HK | 1-1/2" | 35-1/2" - 36" | 138" | Inside | 37-1/2" | 41-1/2" | 4-1/4" |
| U20/13 HK U20-HK U30-HK | 2-1/2" | 54" | 127-1/2" | Outside | 36-1/2" | 41-3/4" | 6" |



Tel: 800.285.0666 | sales@wastequip.com | www.galbreathproducts.com

Wastequip is the leading North American manufacturer of waste and recycling equipment for collecting, processing and transporting recyclables and solid or liquid waste. August 2015 © Wastequip, all rights reserved. Specifications subject to improvement without notice. Equipment displayed should be operated by properly trained personnel. Operators should become familiar with OSHA, ANSI and any other applicable standards or laws for using this equipment. Improper use, misuse, or lack of maintenance could cause injury to people and/or property. Photos used in the literature are illustrative only. We assume no liability or responsibility for proper training/operation of equipment not manufactured by Wastequip. We reserve the right to make changes at any time without notice. Information contained within this literature is intended to be the most accurate available at time of printing.