



**MINIMAX™**

 **labrie**  
Labrie Enviroquip Group

  
**CNG READY**  
**SINCE 2001**



# LABRIE MINIMAX™

## BECAUSE SOMETIMES IT PAYS TO HAVE A SMALL TRUCK

Throughout our history we have proven our reputation as both an innovator and an industry leader in bringing optimal collection solutions to our customers while delivering the maximum value for every dollar spent. With this in mind, we started considering solutions for short routes, missed pick ups, parks and recreation, airports, university campuses and all the other places where a smaller truck just makes more sense.

### THE MINIMAX™ IS THE ANSWER.

Completely redesigned and built tougher, this truck is the ideal solution for optimizing your route efficiency and reducing costs.

### LEGENDARY LABRIE™ ENGINEERING, QUALITY AND PERFORMANCE COMPACTED INTO A SMALLER SOLUTION.

As the side loader market leader, we designed the Minimax™ to stand up to our reputation as the industry leader of quality, innovative solutions. To that end, we've included all the best features of our larger side loaders into the Minimax™ to ensure it is the most productive and reliable truck in its category.

- 10, 12 and 14 yd<sup>3</sup> body configurations available in manual, semi or fully automated
- Trusted Helping Hand™ arm with standard 84" reach on automated configuration
- Full eject dumping system for a safe unloading process
- Multiplex electrical system
- Standard Durascop™ nitrited packer/ejector cylinders with shavers



## MINIMAX™

BODY DIMENSIONS		2 axles Imperial 10 cu.yd. (7.6m <sup>3</sup> )	2 axles Imperial 12 cu.yd. (9.2m <sup>3</sup> )	2 axles Imperial 14 cu.yd. (10.7m <sup>3</sup> )
A	O.A. Length	202 in (5130 mm)	216 in (5486 mm)	238 in (6045 mm)
B	O.A. Height above frame	78 in (1981 mm)	78 in (1981 mm)	78 in (1981 mm)
C	Width <sup>1,2</sup>			
	Rear posts	78 in (1981 mm)	78 in (1981 mm)	78 in (1981 mm)
	O.A. width (Manual) O.A. width (Automated)	96 in (2438 mm) 97 in (2464 mm)	96 in (2438 mm) 97 in (2464 mm)	96 in (2438 mm) 97 in (2464 mm)
D	Tailgate length	22 in (559 mm)	36 in (914 mm)	58 in (1473 mm)
E	Loading height above frame	20 in (508 mm)	20 in (508 mm)	20 in (508 mm)
F	Packer Stroke <sup>2</sup>	48 in (1219 mm)	48 in (1219 mm)	48 in (1219 mm)
G	Packer Height <sup>2</sup>	17 in (432 mm)	17 in (432 mm)	17 in (432 mm)
H	Packer Width <sup>2</sup>	63 in (1600 mm)	63 in (1600 mm)	63 in (1600 mm)
I	Packer penetration inside body <sup>2</sup>	16 in (406 mm)	16 in (406 mm)	16 in (406 mm)
J	Hopper door width Manual/ Semi-Automated Automated	58 in (1473 mm)	58 in (1473 mm)	58 in (1473 mm)
		39 in (990 mm)	39 in (990 mm)	39 in (990 mm)
K	Hopper door height	45 in (1143 mm)	45 in (1143 mm)	45 in (1143 mm)
L	O.A. Length, tailgate raised	266 in (6756 mm)	266 in (6756 mm)	266 in (6756 mm)
M	O.A. Height, tailgate raised, above frame	100 in (2540 mm)	114 in (2896 mm)	136 in (3454 mm)

1 O.A. width is at the fenders (Manual) or at the gripper (Automated) / 2 Not shown on drawing

BODY SPECIFICATIONS	
Body trough	3/16in Hardox 450
Body side walls	12ga A715 GR80
Body roof	12ga A715 GR80
HOPPER SPECIFICATIONS	
Body trough	3/16in Hardox 450
Hopper sides	3/16 in QT-100
Hopper access door	14ga A1011
TAILGATE SPECIFICATIONS	
Sides and rear walls	12ga A1011 GR80
Upper tube frame	10 in x 4.75 in x 12ga
Bottom tube frame	5 in x 2 in x 3/16 in
Framing sides	5 in x 2 in x 1/8 in
PACKER SPECIFICATIONS	
Top of packing ram	3/16in Hardox 450
Face plate of packing ram	3/16in Hardox 450
ARM SPECIFICATIONS	
Pick up possibilities	32 to 96gal. carts (120 to 360L)
Lift capacities	400 lbs (181 kg)
Arm reach	84 in (2134 mm)

HYDRAULIC SPECIFICATIONS	
Pump	T6C (Manual) / T6CC (Automated)
Pump flow packer	20 gpm @ 1200 rpm
Pump flow arm	14 gpm @ 1200 rpm
Hydraulic tank	39gal. (148L)
Hydraulic system pressure	2500 psi (13.8 MPa)
Body control valve	Parker VG35
Arm control valve	Sauer-Danfoss PVG32
Return line filter	150 gpm, 5 micron
TAILGATE SPECIFICATIONS	
Sides and rear walls	12ga A1011
Upper tube frame	10 in x 4.75 in x 12ga
Bottom tube frame	5 in x 2 in x 3/16 in
Framing sides	5 in x 2 in x 1/8 in
CYLINDERS	
Packer	Telescopic, 3 stages, 4.5 in x 138 in
tailgate	2.5 in x 1.75 in x 31 in
Horizontal extension	2 in x 1.25 in x 70 in
Lifting	3 in x 1.5 in x 16 in
Grabber	1.5 in x 1 in x 6.5 in

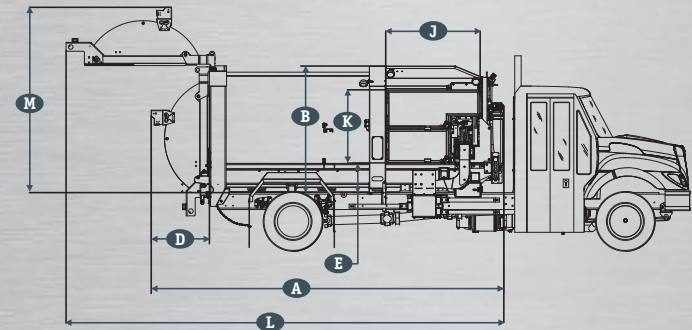





## LABRIE ENVIROQUIP GROUP

Labrie Enviroquip Group is one of the largest manufacturer's of refuse and recycling collection vehicles in North America. Our product lines of Labrie, Leach, and Wittke are renowned to be the most reliable, efficient, productive, and innovative in the solid waste industry today.

Throughout our history, we have been recognized for the design and production of the highest quality vehicles available on the market, while our customers benefit from a single trusted source of engineering expertise.

At Labrie we continually push the boundaries of innovation to provide a greener, safer, smarter and more efficient way of waste management and collection.

We are committed to building and delivering the finest refuse collection equipment in the industry to suit all of your collection needs. With the strongest dealer network in the industry (over 45 distribution points across the continent), our stock and demo program, engineering expertise, and the Labrieplus 24/7 customer support center, Labrie delivers the ultimate ownership experience.

Labrieplus is Labrie's full service customer support center located in the U.S. Its mission is to provide quality replacement parts and premium hands-on field support to Labrie equipment owners. Labrieplus is the single source for Labrie, Leach, Wittke and Pendpac OEM and selected all makes of parts.

## DRIVE EXCELLENCE

Labrie is certified ISO 9001-2008 and attests to the quality of these products. Labrie has made every reasonable effort to ensure that the information contained in this brochure is accurate. However, we accept no responsibility for any errors or omissions, and we reserve the right to modify designs, characteristics and products at any time. Contact Labrie for prices and options or to obtain the phone number of your local Labrie distributor. For the most recent version of our spec sheets, please go to Labrie website at [www.labriegrup.com](http://www.labriegrup.com). In case of discrepancy, the Web version takes precedence over any printed literature.

© Labrie Enviroquip Group 2015. - Printed in USA



**Labrie** (Head Office)

175-B, route Marie-Victorin, Levis, Quebec, Canada G7A 2T3

Toll free: 800 463-6638

[info@labriegrup.com](mailto:info@labriegrup.com)

Phone: 418 831-8250 Fax: 418 831-5255

[www.labriegrup.com](http://www.labriegrup.com)

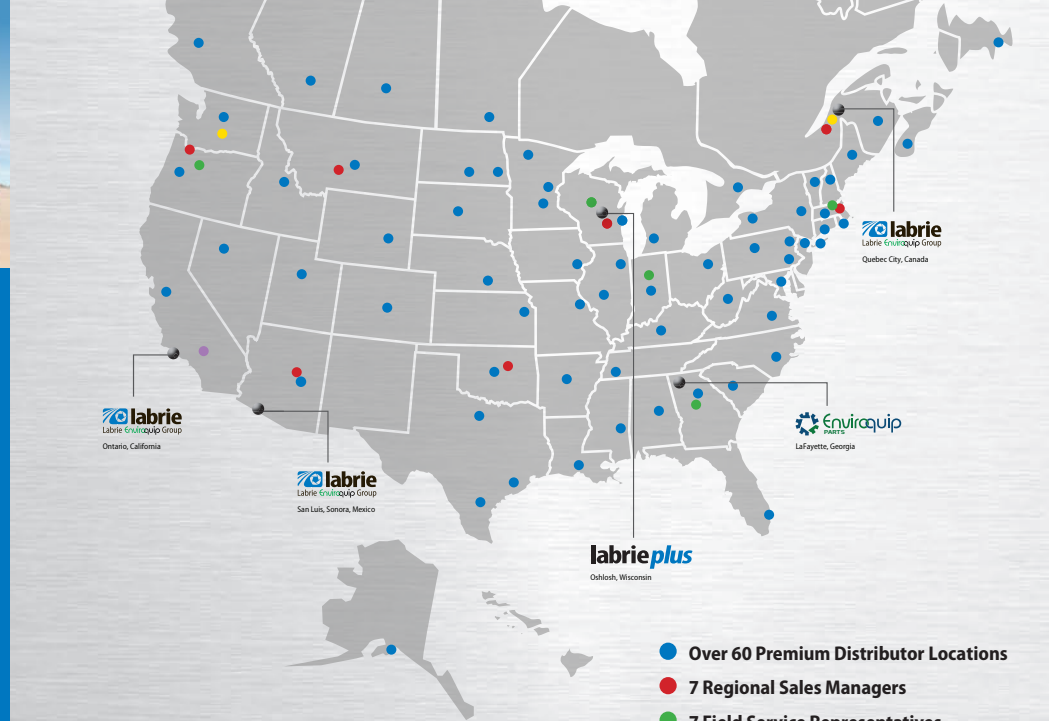

- Over 60 Premium Distributor Locations
- 7 Regional Sales Managers
- 7 Field Service Representatives
- 2 Technical Advisors / Demo Operators
- 1 National Account Manager

Visit [www.labriegrup.com](http://www.labriegrup.com) to view a complete listing of our premium distributor network

## PREMIUM PRODUCTS COME WITH PREMIUM SUPPORT.

Labrie is committed to delivering the ultimate ownership experience throughout North America. Our pursuit of excellence continues long after a Leach™, Labrie™ or Wittke™ is put into service.

### OUR NORTH AMERICAN NETWORK IS QUALITY DRIVEN:

- **Labrieplus 24/7 customer support system**, provides quality replacement parts, premium hands-on field and live assistance. Peace of mind guaranteed.
- **A network of over 45 premium distributors** located throughout the United States and Canada are highly trained to assist you; providing live assistance from a dedicated staff of professional representatives to support all of our Leach™, Labrie™ and Wittke™ products.



**Labrieplus** (USA Office)

1981 W. Snell Road, P.O. Box 2785, Oshkosh, Wisconsin, USA 54903-2785

Toll free: 800 231-2771

Phone: 920 233-2770

Fax: 920 232-2496