

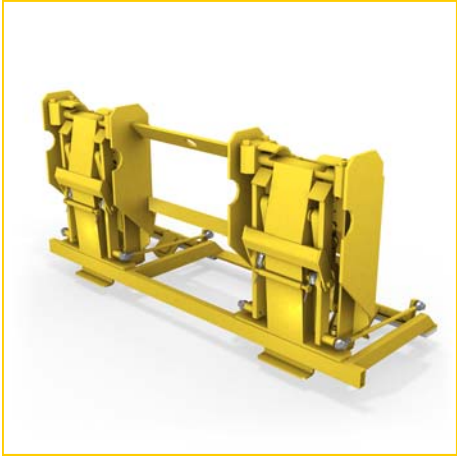

CART TIPPER



***SEMI-AUTOMATED CONTAINER
HANDLING SOLUTIONS
for
SIDE LOADERS***





LABRIE CYLINDER ACTUATED CART TIPPER ONE YEAR LIMITED WARRANTY

Each Labrie Cylinder Actuated Cart Tipper is warranted by the Labrie Environmental Group (“Company”) against defects in material and workmanship for a period of one (1) year provided the Cylinder Actuated Cart Tipper is used in a normal and reasonable manner. This limited warranty is applicable only to the original user-purchaser for a period of one (1) year (as measured from the date of delivery to the original user-purchaser) for the complete unit. This warranty is not transferable.

During the Limited Warranty Period the Company will cause to be repaired or replaced, as the Company may elect, any part or parts of such Cylinder Actuated Cart Tipper that the Company’s examination discloses to be defective in material or workmanship. This warranty is expressly limited to the repair or replacement of any component or part thereof of any Labrie Cylinder Actuated Cart Tipper that is proven to the Company's satisfaction to have been defective in material or workmanship. The Company is not responsible for labor and transportation charges in connection with the replacement or repair of defective parts.

The Labrie Cylinder Actuated Cart Tipper Limited Warranty shall not apply to:

1. Any components or trade accessories that have a separate warranty by the original manufacturer.
2. Normal adjustments and maintenance services.
3. Wear items used for anti-friction purposes.
4. Wear items used for sealing purposes.
5. Failures resulting from the Labrie Cylinder Actuated Cart Tipper being operated in a manner or for a purpose not recommended by the Company, including operation faster than published cycle times.
6. Repairs, modifications or alterations without the express written consent of the Company, which in the Company’s sole judgment, have adversely affected the Labrie Cylinder Actuated Cart Tipper’s operation or reliability as originally designed and manufactured.
7. Items subject to misuse, negligence, accident or maintenance not consistent with Company published guidelines.
8. External damage such as, but not limited to, bent/dented components, sand blasting damage, paint ingested through seals, contamination of fluid.

NOTE The use in the product of any part other than parts approved by the Company may invalidate this warranty. The Company reserves the right to determine, in its sole discretion, if the use of non-approved parts shall invalidate the warranty. Nothing contained in this warranty shall make the Company liable for loss, injury, or damage of any kind to any person or entity resulting from any defect or failure in the machine.

TO THE EXTENT LIMITED BY LAW, THIS WARRANTY IS IN LIEU OF ALL OTHER WARRANTIES, EXPRESS OR IMPLIED, INCLUDING WITHOUT LIMITATION, ANY IMPLIED WARRANTIES OF MERCHANTABILITY AND FITNESS FOR A PARTICULAR PURPOSE.

This warranty is also in lieu of all other obligations or liabilities on the part of the Company, including but not limited to, liability for incidental and consequential damages on the part of the Company or the seller. Labrie Environmental Group makes no representation that the machine has the capacity to perform any functions other than as contained in the Company’s written literature, catalogs or specifications accompanying delivery of the Labrie Cylinder Actuated Cart Tipper. No person or affiliated company representative is authorized to alter the terms of this warranty, to give any other warranties or to assume any other liability on behalf of the Company in connection with the sale, servicing or repair of any machine manufactured by the Company.

Labrie Environmental Group reserves the right to make design changes or improvements in its products without imposing any obligation upon itself to change or improve previously manufactured products.

labrieplus
3630 Stearns Drive
P.O. Box 2785
Oshkosh, WI 54903-2785



LABRIE ROTARY ACTUATED CART TIPPER TWO YEAR LIMITED WARRANTY

Each Labrie Rotary Actuated Cart Tipper is warranted by the Labrie Environmental Group (“Company”) against defects in material and workmanship for a period of two (2) years provided the Rotary Actuated Cart Tipper is used in a normal and reasonable manner. This limited warranty is applicable only to the original user-purchaser for a period of two (2) years (as measured from the date of delivery to the original user-purchaser) for the complete unit. This warranty is not transferable.

During the Limited Warranty Period the Company will cause to be repaired or replaced, as the Company may elect, any part or parts of such Rotary Actuated Cart Tipper that the Company’s examination discloses to be defective in material or workmanship. This warranty is expressly limited to the repair or replacement of any component or part thereof of any Labrie Rotary Actuated Cart Tipper that is proven to the Company’s satisfaction to have been defective in material or workmanship. The Company is not responsible for labor and transportation charges in connection with the replacement or repair of defective parts.

The Labrie Rotary Actuated Cart Tipper Limited Warranty shall not apply to:

1. Any components or trade accessories that have a separate warranty by the original manufacturer.
2. Normal adjustments and maintenance services.
3. Wear items used for anti-friction purposes.
4. Wear items used for sealing purposes.
5. Failures resulting from the Labrie Rotary Actuated Cart Tipper being operated in a manner or for a purpose not recommended by the Company, including operation faster than published cycle times.
6. Repairs, modifications or alterations without the express written consent of the Company, which in the Company’s sole judgment, have adversely affected the Labrie Rotary Actuated Cart Tipper’s operation or reliability as originally designed and manufactured.
7. Items subject to misuse, negligence, accident or maintenance not consistent with Company published guidelines.
8. External damage such as, but not limited to, bent/dented components, sand blasting damage, paint ingested through seals, contamination of fluid.

NOTE The use in the product of any part other than parts approved by the Company may invalidate this warranty. The Company reserves the right to determine, in its sole discretion, if the use of non-approved parts shall invalidate the warranty. Nothing contained in this warranty shall make the Company liable for loss, injury, or damage of any kind to any person or entity resulting from any defect or failure in the machine.

TO THE EXTENT LIMITED BY LAW, THIS WARRANTY IS IN LIEU OF ALL OTHER WARRANTIES, EXPRESS OR IMPLIED, INCLUDING WITHOUT LIMITATION, ANY IMPLIED WARRANTIES OF MERCHANTABILITY AND FITNESS FOR A PARTICULAR PURPOSE.

This warranty is also in lieu of all other obligations or liabilities on the part of the Company, including but not limited to, liability for incidental and consequential damages on the part of the Company or the seller. Labrie Environmental Group makes no representation that the machine has the capacity to perform any functions other than as contained in the Company’s written literature, catalogs or specifications accompanying delivery of the Labrie Rotary Actuated Cart Tipper. No person or affiliated company representative is authorized to alter the terms of this warranty, to give any other warranties or to assume any other liability on behalf of the Company in connection with the sale, servicing or repair of any machine manufactured by the Company.

Labrie Environmental Group reserves the right to make design changes or improvements in its products without imposing any obligation upon itself to change or improve previously manufactured products.

labriepius
3630 Stearns Drive
P.O. Box 2785
Oshkosh, WI 54903-2785



CART TIPPER FEATURES

MODEL	Actuator Type	Features
A-100 Series	Helac Rotary	<ul style="list-style-type: none"> • Fold Under, compact design • Long reach • Sweeping motion to pick up containers at varying heights • Available for North American, European or universal applications • Two year limited warranty
C-220 Series	Hydraulic Cylinder	<ul style="list-style-type: none"> • Fold Under, compact design • Long reach • High dump models available, ideal for comingle applications • Sweeping motion to pick up containers at varying heights • Available for North American, European or universal applications • One year limited warranty
C-330 Series	Hydraulic Cylinder	<ul style="list-style-type: none"> • Narrow depth, flat mount design • Ideal for high sill applications • Sweeping motion to pick up containers at varying heights • Available for North American, European or universal applications • One year limited warranty
A-150 Series	Helac Rotary	<ul style="list-style-type: none"> • Hydraulic grabber arm design • Can pick up virtually all plastic carts and barrels • Arms fold away for hopper access • Models available with 90°, 180° grabber opening ranges • Two year limited warranty
<i>All Labrie Cart Tippers feature a high-visibility powder coated finish!</i>		



CART TIPPER CROSS-REFERENCE

LABRIE MODEL	COMPARE TO BAYNE MODEL	COMPARE TO PERKINS MODEL
LA-220	TL Series	D6235 D6070 D6071
LE-220	ETL Series	**
LT-220	CTL	D6250 D6275
L-150 L-159	GRL Series	D6098 Series



CART TIPPERS

A-100 SERIES for SIDE LOADERS

MODEL:	L-010, L-020, L-030
ANSI RATING:	ANSI Z 245.60-1996
APPLICATION:	SIDE LOADERS
LIFT TYPE:	ROTARY ACTUATOR
HYDRAULIC FLOW:	2-3 GPM
HYDRAULIC PRESSURE:	1,800-2,100 PSI
CYCLE TIME:	8-10 SECONDS
MAXIMUM LOAD:	250 LBS
CART COMPATIBILITY:	TYPE B (DOMESTIC 2-BAR) TYPE C (EUROPEAN COMB-STYLE) UNIVERSAL
NOTES:	FOLD UNDER ,COMPACT DESIGN



OPERATOR-FRIENDLY, PLUS EASIER SERVICE & MAINTENANCE!

- A powerful rotary actuator provides smooth & reliable operation under continuous use (up to 800 cycles per shift).
- Fewer moving parts provide safety and reliability.
- Bolt-on mounting plate for quick replacement.
- Sweeping action automatically adjusts to varying heights and uneven terrain with a positive lock on the container.
- Dumps higher and deeper into the hopper to minimize spillage and reduce the number of packer cycles.
- Models available for either Type B Domestic (L030) or Type C European (L020) containers.
- Universal model (L010) can pick up both Type B Domestic and Type C European containers.

LABRIE Cart Tipper are exclusively available through the Labrie Environmental Group and their Authorized Distributors.

labrieplus

(800) 231-2771
www.labrieplus.com



CART TIPPERS

A-100 SERIES for REAR LOADERS

The A-100 Series Cart Tippers are designed to operate with fewer moving parts to deliver the highest level of safety and reliability. Ideal for compact installations, providing clearance for commercial carts with unrestricted access to the hopper area for hand-loading.

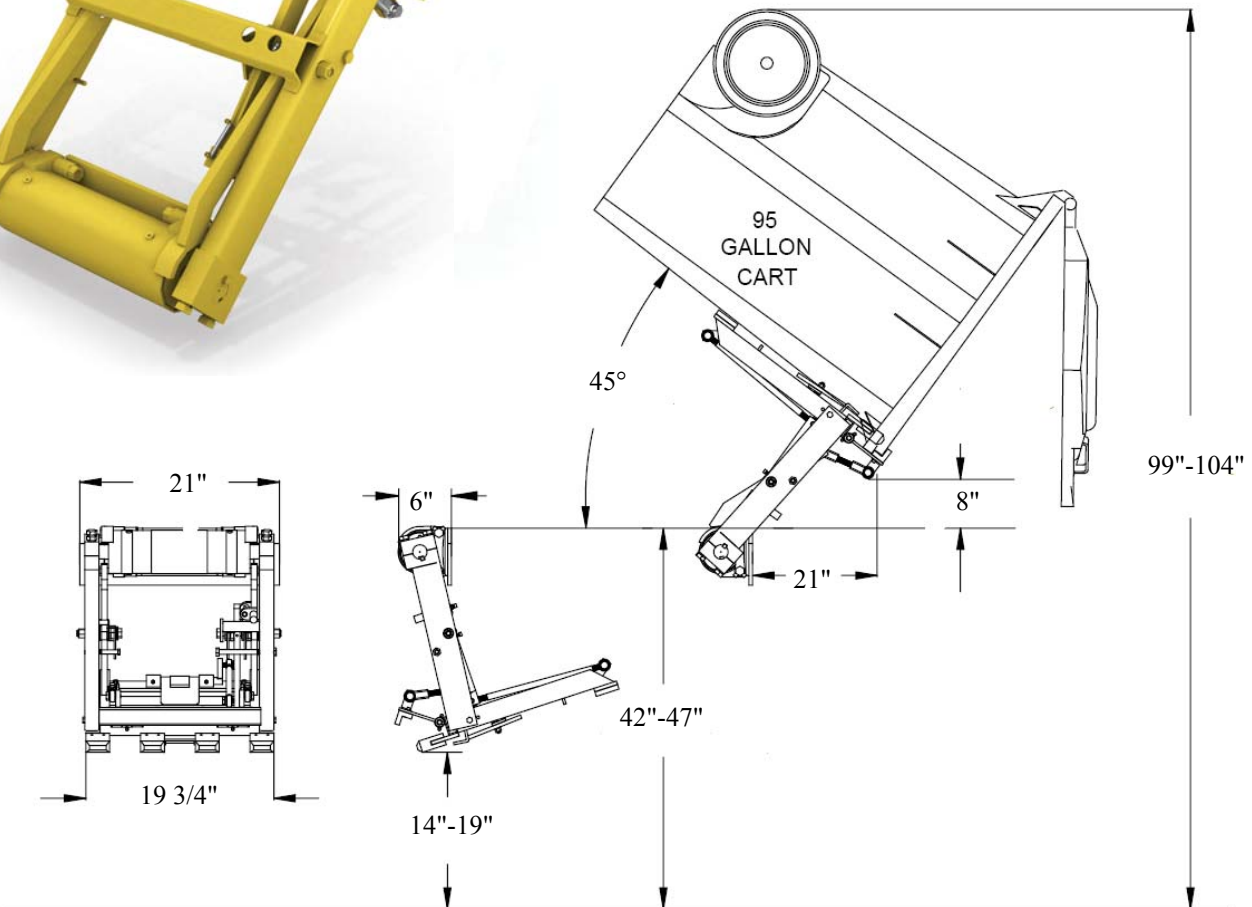

Dimensions accommodate most ANSI Z245.60-1996 Type B carts (domestic style 2-bar) and most ANSI Z245.60-1996 Type C carts (European style), but may vary due to container specifications and/or applications. All dimensions are approximate.

For more information on LABRIE Cart Tippers and what they can do to increase your bottom line, please contact your authorized Labrie Environmental Group Distributor or call us direct at LabriePlus!



CART TIPPERS

C-220 SERIES for SIDE LOADERS

MODEL:	LA-220, LE-220, LT-220
ANSI RATING:	ANSI Z 245.60-1996
APPLICATION:	SIDE LOADERS
LIFT TYPE:	HYDRAULIC CYLINDER
HYDRAULIC FLOW:	2-3 GPM
HYDRAULIC PRESSURE:	1,800-2,100 PSI
CYCLE TIME:	8-10 SECONDS
MAXIMUM LOAD:	400 LBS
CART COMPATIBILITY:	TYPE B (DOMESTIC 2-BAR) TYPE C (EUROPEAN COMB-STYLE) UNIVERSAL
NOTES:	FOLD UNDER ,COMPACT DESIGN



OPERATOR-FRIENDLY, PLUS EASIER SERVICE & MAINTENANCE!

- A powerful, easy to maintain trunnion-mounted hydraulic cylinder provides smooth & reliable operation under continuous use (up to 800 cycles per shift).
- Bolt-on mounting plate for quick replacement.
- Sweeping action automatically adjusts to varying heights and uneven terrain with a positive lock on the container.
- Dumps higher and deeper into the hopper to minimize spillage and reduce the number of packer cycles.
- Models available for either Type B Domestic (LA-220) or Type C European (LE-220) containers.
- Universal model (LT-220) can pick up both Type B Domestic and Type C European containers.
- Also available in double tipper configurations.

LABRIE Cart Tipper are exclusively available through the Labrie Environmental Group and their Authorized Distributors.

labrieplus

(800) 231-2771
www.labrieplus.com



CART TIPPERS

C-220 SERIES for SIDE LOADERS

The C-220 Series Cart Tippers are designed to operate with fewer moving parts to deliver the highest level of safety and reliability. Ideal for compact installations, providing clearance for commercial carts with unrestricted access to the hopper area for hand-loading.

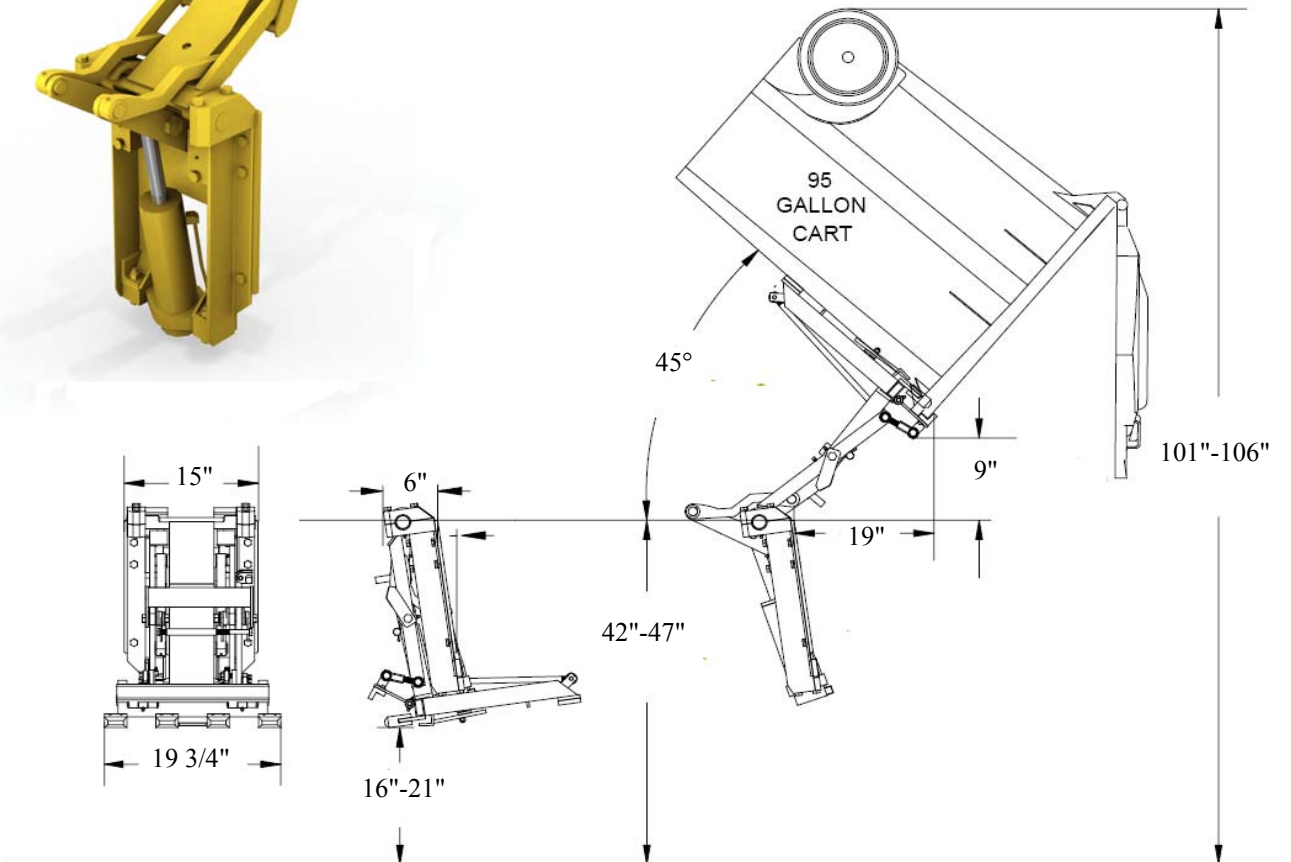

Dimensions accommodate most ANSI Z245.60-1996 Type B carts (domestic style 2-bar) and most ANSI Z245.60-1996 Type C carts (European style), but may vary due to container specifications and/or applications. All dimensions are approximate.

For more information on LABRIE Cart Tippers and what they can do to increase your bottom line, please contact your authorized Labrie Environmental Group Distributor or call us direct at LabriePlus!

LabriePlus is a proud subsidiary of



©2009 Labrie Environmental Group



CART TIPPERS

C-220 SERIES for SIDE LOADERS

HIGH DUMP MODELS

MODEL:	LXA-220, LXE-220, LXT-220
ANSI RATING:	ANSI Z 245.60-1996
APPLICATION:	SIDE LOADERS
LIFT TYPE:	HYDRAULIC CYLINDER
HYDRAULIC FLOW:	2-3 GPM
HYDRAULIC PRESSURE:	1,800-2,100 PSI
CYCLE TIME:	8-10 SECONDS
MAXIMUM LOAD:	400 LBS
CART COMPATIBILITY:	TYPE B (DOMESTIC 2-BAR) TYPE C (EUROPEAN COMB-STYLE) UNIVERSAL
NOTES:	FOLD UNDER ,COMPACT DESIGN FOR COMINGLE APPLICATION



OPERATOR-FRIENDLY, PLUS EASIER SERVICE & MAINTENANCE!

- A powerful, easy to maintain trunnion-mounted hydraulic cylinder provides smooth & reliable operation under continuous use (up to 800 cycles per shift).
- Bolt-on mounting plate for quick replacement.
- Sweeping action automatically adjusts to varying heights and uneven terrain with a positive lock on the container.
- Dumps higher and deeper into the hopper to minimize spillage and reduce the number of packer cycles.
- Models available for either Type B Domestic (LXA-220) or Type C European (LXE-220) containers.
- Universal model (LXT-220) can pick up both Type B Domestic and Type C European containers.

LABRIE Cart Tippers are exclusively available through the Labrie Environmental Group and their Authorized Distributors.

labrieplus

(800) 231-2771
www.labrieplus.com



CART TIPPERS

**C-220 SERIES for SIDE LOADERS
HIGH DUMP MODELS**

The C-220 High Dump Series Cart Tipper is designed to operate with fewer moving parts to deliver the highest level of safety and reliability. Ideal for compact installations, providing clearance for commercial carts with unrestricted access to the hopper area for hand-loading. Dumps higher into the hopper making it ideal for comingle applications.

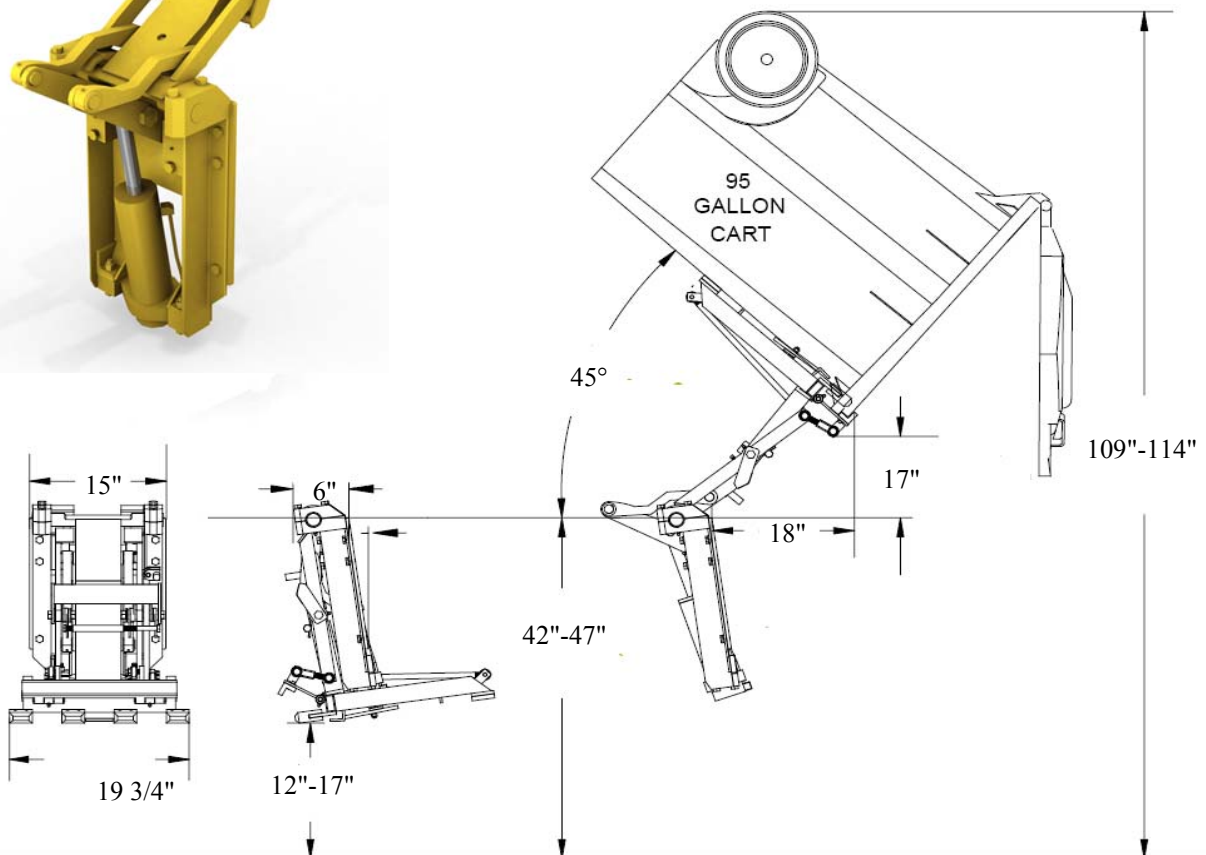

Dimensions accommodate most ANSI Z245.60-1996 Type B carts (domestic style 2-bar) and most ANSI Z245.60-1996 Type C carts (European style), but may vary due to container specifications and/or applications. All dimensions are approximate.

For more information on LABRIE Cart Tipper and what they can do to increase your bottom line, please contact your authorized Labrie Environmental Group Distributor or call us direct at LabriePlus!

LabriePlus is a proud subsidiary of



©2009 Labrie Environmental Group



CART TIPPERS

C-330 SERIES for SIDE LOADERS

MODEL:	LA-330, LE-330, LT-330
ANSI RATING:	ANSI Z 245.60-1996
APPLICATION:	SIDE LOADERS
LIFT TYPE:	HYDRAULIC CYLINDER
HYDRAULIC FLOW:	2-3 GPM
HYDRAULIC PRESSURE:	1,800-2,100 PSI
CYCLE TIME:	8-10 SECONDS
MAXIMUM LOAD:	350 LBS
CART COMPATIBILITY:	TYPE B (DOMESTIC 2-BAR) TYPE C (EUROPEAN COMB-STYLE)
NOTES:	FLAT COMPACT DESIGN FOR HIGH SILL APPLICATIONS



OPERATOR-FRIENDLY, PLUS EASIER SERVICE & MAINTENANCE!

- A powerful, easy to maintain trunnion-mounted hydraulic cylinder provides smooth & reliable operation under continuous use (up to 800 cycles per shift).
- Bolt-on mounting plate for quick replacement.
- Sweeping action automatically adjusts to varying heights and uneven terrain with a positive lock on the container.
- Dumps higher and deeper into the hopper to minimize spillage and reduce the number of packer cycles.
- Models available for either Type B Domestic (LA-330) or Type C European (LE-330) containers.
- Universal model (LT-330) can pick up both Type B Domestic and Type C European containers.
- Also available in double & triple tipper configurations.

LABRIE Cart Tippers are exclusively available through the Labrie Environmental Group and their Authorized Distributors.

labrieplus

(800) 231-2771
www.labrieplus.com



CART TIPPERS

C-330 SERIES for SIDE LOADERS



The C-330 Series Cart Tippers are designed to operate with fewer moving parts to deliver the highest level of safety and reliability. Ideal for compact installations, providing clearance for commercial carts with unrestricted access to the hopper area for hand-loading. Dumps higher into the hopper to reduce the number of packer cycles.

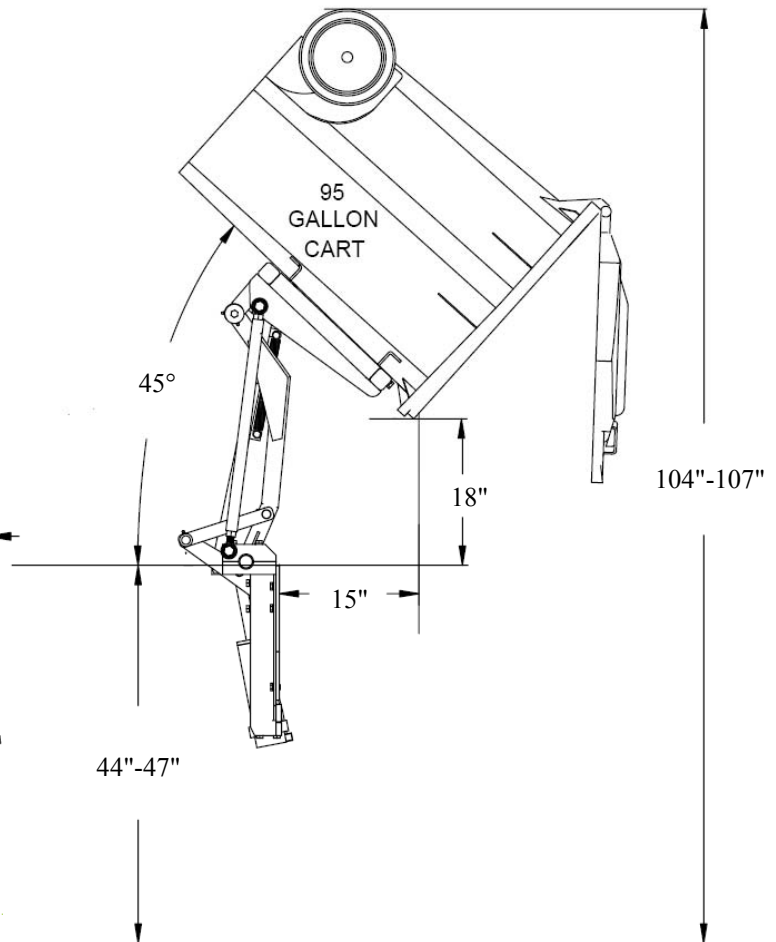
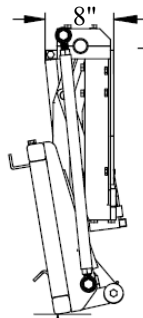
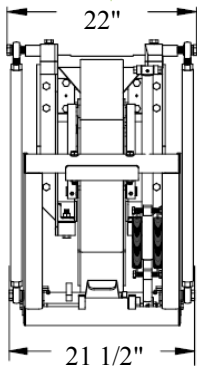

Dimensions accommodate most ANSI Z245.60-1996 Type B carts (domestic style 2-bar) and most ANSI Z245.60-1996 Type C carts (European style), but may vary due to container specifications and/or

For more information on LABRIE Cart Tippers and what they can do to increase your bottom line, please contact your authorized Labrie Environmental Group Distributor or call us direct at LabriePlus!

LabriePlus is a proud subsidiary of



©2009 Labrie Environmental Group



CART TIPPERS

A-150 SERIES for SIDE LOADERS

MODEL:	L-150, L-159
ANSI RATING:	ANSI Z 245.60-1996
APPLICATION:	SIDE LOADERS
LIFT TYPE:	ROTARY ACTUATOR
HYDRAULIC FLOW:	2-3 GPM
HYDRAULIC PRESSURE:	1,800-2,100 PSI
CYCLE TIME:	8-10 SECONDS
MAXIMUM LOAD:	300 LBS
CART COMPATIBILITY:	ANY GRABBER COMPATIBLE
NOTES:	SPACE SAVING ARMS



OPERATOR-FRIENDLY, PLUS EASIER SERVICE & MAINTENANCE!

- A powerful rotary actuator provides smooth & reliable operation under continuous use (up to 800 cycles per shift).
- Universal application design can be mounted on virtually all rear, side and front loaders.
- Bolt-on mounting plate for quick replacement.
- Unique three-gripper design is compatible with most two wheeled carts and drums.
- Even handles carts with damaged lifting apparatus, such as missing lifting bars, making it the most robust grabber-style cart tipper on the market.
- Space saving arms fold away hydraulically for total access to the hopper when not in use.
- Rubber straps on the arms and faceplate ensure a secure grip while protecting your carts.
- Does not interfere with the packer cycle, speeding the loading process.

LABRIE Cart Tippers are exclusively available through the Labrie Environmental Group and their Authorized Distributors.

labrieplus

(800) 231-2771
www.labrieplus.com



CART TIPPERS

A-150 SERIES for SIDE LOADERS

The A-150 Series Cart Tippers are designed to operate with fewer moving parts to deliver the highest level of safety and reliability. Ideal for compact installations, providing clearance for commercial carts with unrestricted access to the hopper area for hand-loading.

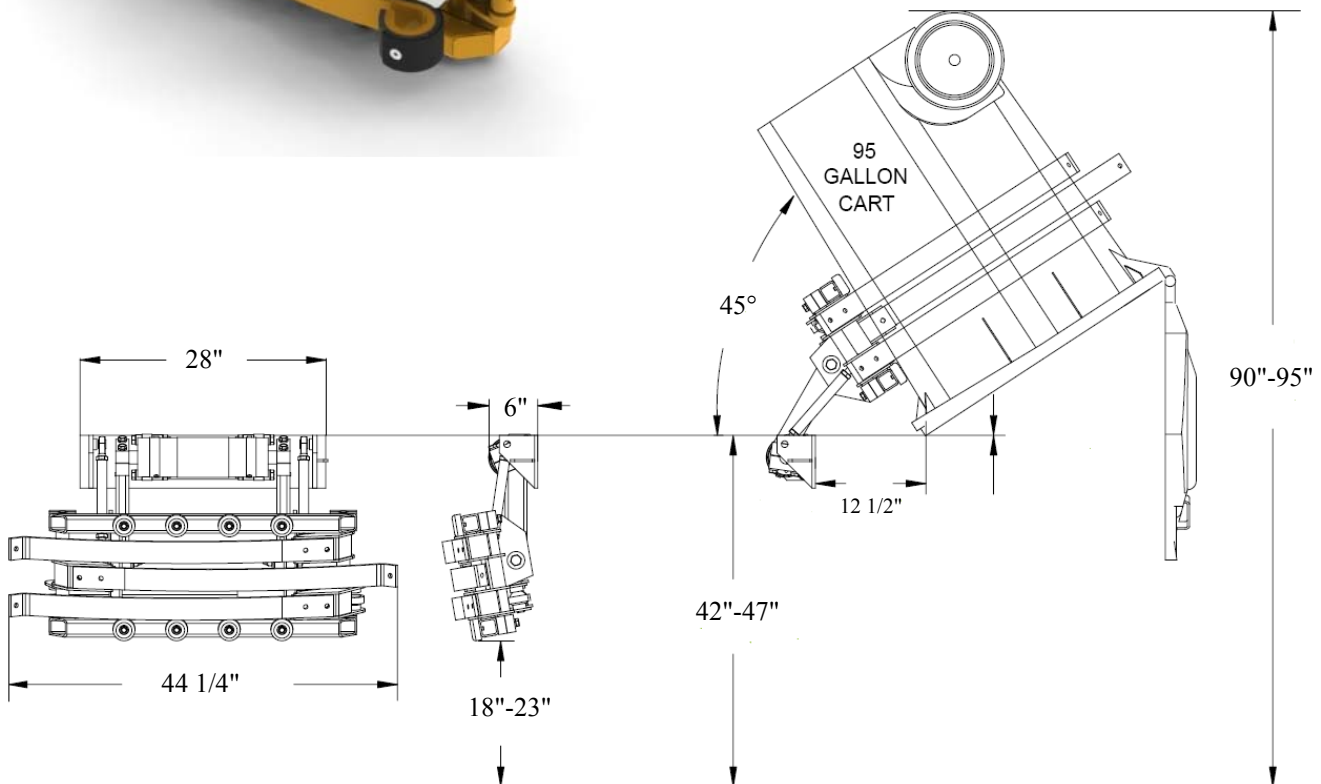

Dimensions accommodate most ANSI Z245.60-1996 Type B carts (domestic style 2-bar) and most

For more information on LABRIE Cart Tippers and what they can do to increase your bottom line, please contact your authorized Labrie Environmental Group Distributor or call us direct at LabriePlus!

LabriePlus is a proud subsidiary of



©2009 Labrie Environmental Group

**FOR MORE INFORMATION OR TO
ORDER LABRIE CART TIPPER
PRODUCTS, PLEASE CONTACT:**

labrie *plus*

**3630 Stearns Drive
P.O. Box 2785
Oshkosh, WI 54903-2785
(800) 231-2771
www.labrieplus.com**

LabriePlus is a proud subsidiary of

 **labrie**
environmental group

labrie *plus*

 **Juggler**[™]

 **LEACH**

 **LABRIE**

WITTKÉ

INDUSTRIAL
LIFTERS[®]