

Air-Weigh®

Self-Weighing Truck and Trailer Scales™



LoadMaxx™ Scale

Installation Guide

for Trucks and Tractors with
Air Pressure Drive

PN: 901-0119-000 R0

TABLE OF CONTENTS

I. SCALE OVERVIEW.....	4
1. LoadMaxx Tractor Scale Overview	5
2. Installation Overview for LoadMaxx Scale System	6
A. Overview for the Electronic Components Installation ..	6
B. Overview for the AP Drive Sensor Installation	6
C. Overview for other AP Sensor(s) Installation	7
II. INSTALLATION COMPONENTS.....	8
III. TOOLS REQUIRED (CUSTOMER SUPPLIED).....	9
IV. INSTALLING THE LOADMAXX DISPLAY.....	10
1. Installing the Tractor Cab Display	10
A. Preparing the Cab Display for Installation:.....	10
B. Installing the Cab Display	10
2. Mounting the ComLink Behind Dash.....	11
A. Installing the Display and Connecting the Wiring Harness.....	11
3. Connecting the ComLink Wiring Harness.....	12
A. Connecting the ComLink to Power	12
B. Secure Cables and Reassemble the Dash	13
V. INSTALLING AIR SUSPENSION SENSOR(S)	15
1. Air Line Installation for each leveling valve.....	15
A. Route Air Line from Air Suspension	15
B. Routing Air line for Dedicated Tractor / Trailer Scale	16
2. Installing Sensor(s).....	19
A. Installing Air Pressure Sensor (s).....	19
B. Installing Scales with a steer axle Deflection Sensor	21
VI. FOR FURTHER INFORMATION.....	24

VII. LIMITED WARRANTY25
1. Procedure for Warranty Claims 26

I. SCALE OVERVIEW

The Air-Weigh® Scale for trucks and tractors with AP (Air Pressure) drive suspension includes a dashboard-mounted display, a LoadMaxx™ ComLink, mounting cables, air sensor cable(s), and air pressure sensor(s) with a Street - T for a drive suspension with air bag height leveling valve(s).

This **Installation Guide** (p/n: 901-0119-000) gives instructions for scale installations on vehicles having air drive suspensions, possibly in combination with air steer suspensions, dedicated tractor and trailer configurations, and/or spring steer suspension. It provides all the instructions needed to install air pressure sensors on the various vehicle suspensions. See **Table 5. Kit Configuration Sensor Assignment** for more detail on the various vehicle configurations.

Follow the installation procedures in this guide exactly for the most accurate weighing.

Table 1. Specifications

Display	<ul style="list-style-type: none"> • Diameter: 2.43 inches (61.7 mm) • Height: 3.10 inches (78.7 mm) • Weight: 4.7 oz. (133 g) • Operating Temperature Range: 0° to 50°C (32° to 122°F) • Input voltage: Supplied by LoadMaxx ComLink
Tractor ComLink (5901)	<ul style="list-style-type: none"> • Length: 2.84 inches (72.1 mm) • Width: 5.2 inches (132.1 mm) • Height: 1.12 inches (28.4 mm) • Operating Temperature Range: - 40° to 85°C (- 40° to 185°F) • Input Voltage: 9.5V DC to 32V DC • Alarm Output Circuit Limit: 1.0 amps
Weigh Reading Accuracy	<ul style="list-style-type: none"> • Axle with Air Sensor: ±300 lbs (140 kgs) per axle group

1. LoadMaxx Tractor Scale Overview

The LoadMaxx on-board scale converts tractor and trailer suspension loads to an accurate on-ground weight by comparing empty and loaded axle group weights with empty and loaded suspension pressures. Once calibrated, the scale displays accurate weights for any air suspension load.

The scale displays the actual on-ground weight of each axle group to within 300 pounds (140 kilograms). An axle group is defined by the Height Control Valve(s) (HCV), or leveling valve(s), on the air suspension. For instance, a tandem drive axle suspension typically has only one HCV. The two drive axles make up a single group and the displayed weight will be for the total tandem weight.

The LoadMaxx on-board scale can display up to eight axle groups on one tractor/trailer combination. Once the LoadMaxx is calibrated for weight, it is not necessary to recalibrate unless the suspension characteristics change.

Any tractor equipped with a LoadMaxx Tractor Scale will automatically display trailer weight data from Air-Weigh equipped trailers. No re-calibration or trailer ID entry is required. No special tractor/trailer connection is necessary because trailer weight data is transmitted over the vehicle's existing 7-wire cable (J-560) without any interference. This is a true drop and hook application.

NOTE

Following installation, you must calibrate the scale before you can use it to determine axle group and vehicle weight. For instructions on calibration, please consult p/n 901-0114-000, LoadMaxx Calibration and Operations Manual.

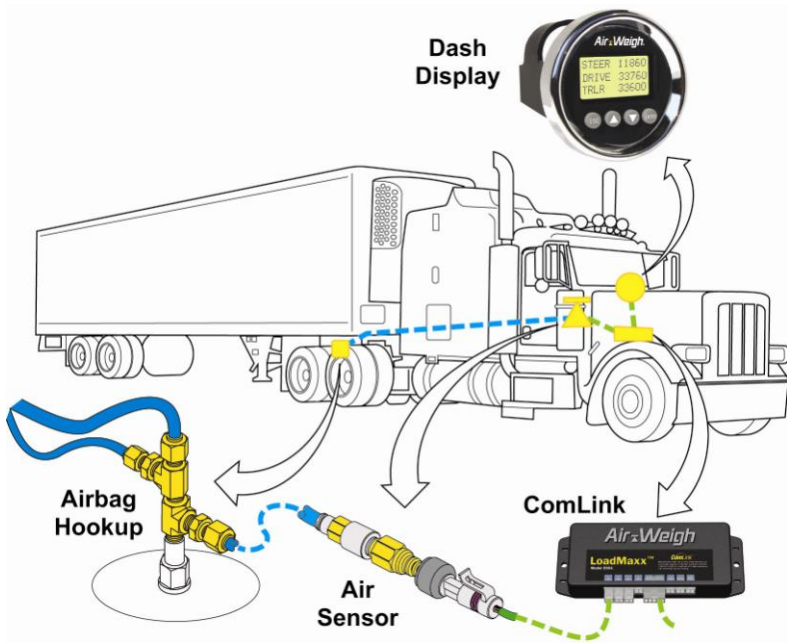

AW0099-1001A

Figure 1. AP Drive Sensor Hookup

2. Installation Overview for LoadMaxx Scale System

This guide will give all necessary details of the following steps for installing the LoadMaxx Scale System.

A. Overview for the Electronic Components Installation

- Cut hole in dash for display; mount display to dash.
- Mount ComLink beneath dash.
- Connect truck interface cable, i.e., power cable.

B. Overview for the AP Drive Sensor Installation

- For air suspension scales with air bag(s) on the drive suspension, install air pressure sensor(s) under dash.
- Route air line(s) from drive suspension to sensor(s) installed under dash.

C. Overview for other AP Sensor(s) Installation

The air line routing and sensor installations mentioned in this section are in addition to the sensor(s) and cable(s) mentioned in the previous section.

- For scales with a steer axle with air suspension (configurations 5805, 5806, 5815, 5821, 5826, 5827, 5838, 5842, 5852, 5856), route air line(s) from steer axle suspension to sensor(s) installed under dash.
- For scales with lift axles (configurations 5835, 5836, 5838), route air line from lift axle suspension to sensor installed under dash.
- For Dedicated Tractor/Trailer Scales (configurations 5840 – 5860), route trailer suspension air line(s) to sensor(s) installed under dash.
- For scales which calculate the weight at the steer axle from the drive axle suspension (configurations 5800, 5801, 5841, 5845, 5851, 5855, 5860), no steer axle sensor is needed.
- For scales where the steer axle weight is intentionally not displayed (configurations 5803, 5816, 5844, 5850), no steer axle sensor is needed.
- When installing kits with configurations 5807, 5808, 5843, 5846, 5853, 5857 or 5878, which include steer axle deflection sensors, refer to p/n 901-0059-000, Steer Axle Deflection Sensor Kit Installation Guide, for installation instructions.

NOTE

Ensure that each sensor's electrical cable is connected to the correct LoadMaxx port. For a list of the correct port for each sensor, see Table 5, page 22.

II. INSTALLATION COMPONENTS

Table 2. Bill of Materials

Bill of Materials for Kit 2A5800B1A0A0A0A Includes all items listed below:		
PART NUMBER	DESCRIPTION	QTY
010-0063-001	HARDWARE KIT, AW5801, TRUCK	1
010-9008-003	TRACTOR SENSOR ASSEMBLY KIT	1
014-0300-012	CABLE, AW5801, SENSOR, 3 FT.	1
016-0500-036	CABLE, AW5901, TRUCK INTERFACE, COMLINK, J1708 DISPLAY PRIVATE, 5 FT.	1
050-5800-XXX	TRUCK SCALE DISPLAY	1
050-5901-XXX	TRUCK SCALE COMLINK, LOADMAXX	1
164-0008-000	DECAL, 5 TH WHEEL LOCATION	1
164-2001-001	DECAL, CAB, "AIR-WEIGH ON BOARD"	1
901-0039-000	CARD, SENSOR CONFIGURATION, AW5800, BOM LEVEL	1
901-0041-000	CARD, QUICKSTART, AW5800, GENERIC	1
901-0054-000	CARD, AW5800, OPERATIONS, CALIBRATION	1
901-0100-000	INSERT, LOADMAXX, INSTALL GUIDE	1
901-0114-000	MANUAL, LOADMAXX, OPERATIONS, TRACTOR, AIR DRIVE	1
901-0119-000	MANUAL, LOADMAXX, INSTALLATION, AIR DRIVE	1

III. TOOLS REQUIRED (CUSTOMER SUPPLIED)

The list below contains the tools and other materials (customer supplied) to properly install the AP Drive Sensor/s on the tractor/trailer.

- 9/16-inch combination wrench
- Torque wrench, 20 – 80 ft-lb
- 9/16-inch deep well socket with $\frac{3}{8}$ -inch socket handle
- $\frac{1}{2}$ -inch to $\frac{3}{8}$ -inch socket adapter
- Teflon™ pipe thread tape

The following kits' Bills of Materials are listed in section V.1.B, "Routing Air line for Dedicated Tractor / Trailer Scale." They are not included in the LoadMaxx Scale kit.

- Air-line kit. May be purchased from Air-Weigh as p/n 010-0023-000, Suspension Air Line Kit, 1/4" Fitting and Tube.
- Trailer air disconnect kit. May be purchased from Air-Weigh as p/n 010-0028-002 Disconnect Kit, AW5800, Trailer-Direct, Quick Coupler, Fittings.
- Two-trailer air disconnect kit. May be purchased from Air-Weigh as p/n 010-0029-002 Disconnect Kit, AW5800, Two-Trailers-Direct, Quick Couplers, Fittings.

IV. INSTALLING THE LOADMAXX DISPLAY

The installation of an Air-Weigh LoadMaxx Scale on a vehicle includes mounting two major classes of components:

- Electronics components: display, ComLink and power interface cable
- Sensor(s) and sensor cable(s)

1. Installing the Tractor Cab Display

A. Preparing the Cab Display for Installation: Numbers called out in refer to Figure 2 unless otherwise stated.

1. Select a location for the display (1) on the dash panel (5) with at least 3-inch clearance behind the dash panel for the unit and its connections. A higher dash position provides better visibility.
2. Cut a 2 $\frac{1}{8}$ -inch hole (2) in the dash at that location.
3. Remove the hex nuts (4) from the studs (6) on the back of the display (1) to release the mounting bracket (3).

B. Installing the Cab Display

1. Position the display (1) in the hole (2) so that it appears level on the dash, as shown in **Figure 2**.
2. Reinstall the mounting bracket (3) on the back of the display and secure with two nuts (4) on the display studs (6). Tighten the nuts and secure the display to the dash using 6 ft-lbs. of torque. **Do not over tighten the mounting bracket nuts.**

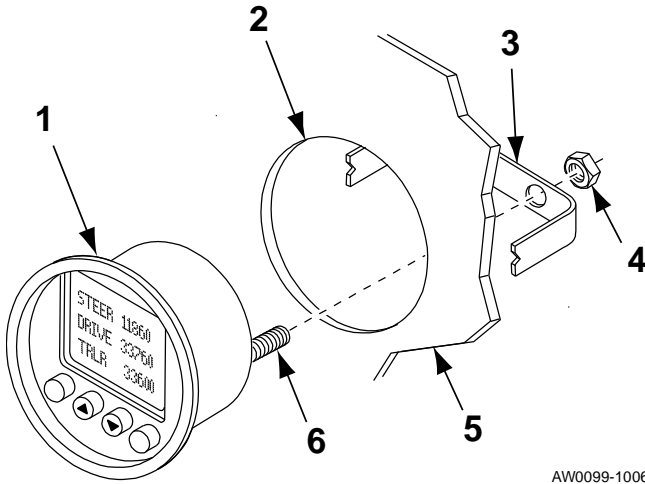

AW0099-1006

Figure 2. Installing the Display

2. Mounting the ComLink Behind Dash

A. Installing the Display and Connecting the Wiring Harness

Select a location behind the dash for the LoadMaxx ComLink, ensuring there is adequate access to the scale and the electrical connections.

The LoadMaxx ComLink should be oriented with the connectors facing downward and installed by any of the following three methods, using the hardware provided.

1. Use wire ties through the holes in the ComLink mounting ears to secure it to any appropriate wire harness behind the dash.

2. Find a flat location where the ComLink can be attached using the 2-sided adhesive tape already in position on the back of the ComLink. Remove all dust, grease or debris from the flat location, using the supplied alcohol pad. Remove one or both of the red strips from the back of the ComLink, exposing the adhesive tape. Place the ComLink against the cleaned flat area and push it hard enough to ensure adhesion. For best results, push the ComLink into place using steady force, being careful not to crack the case. Using this method will make the ComLink more difficult to remove.



CAUTION

Isopropyl alcohol may cause mild irritation on contact with the skin as well as eye irritation. Immediately flush the affected areas with plenty of water, followed by washing affected skin with soap and water. Clothing contaminated with isopropyl alcohol should be removed immediately. Isopropyl alcohol should only be used in properly ventilated areas. Do not use in a confined space. Keep away from flames and other flammable materials.

3. Use self-tapping screws to secure the ComLink to its location.

3. Connecting the ComLink Wiring Harness

A. Connecting the ComLink to Power

The ComLink wiring harness connects the Air-Weigh system to the vehicle's power and ground circuits, and connects the ComLink to the scale display and to the alarm output of a customer-provided warning device.

The 2-pin and 4-pin connectors plug into the scale display. For wires without connectors, consult Table 3, on the next page.

Table 3. Wiring Harness Hookup

Power and Ground Table	
White wire	Vehicle chassis ground
Blue/Black wire with in-line fuse	12VDC or 24VDC ignition hot power
Gray Wire/Brown wire	Alarm Output 1 and 2 (same voltage as vehicle power)
Black wires	Alarm Ground Return 1 and 2

1. Connect the **white** wire to chassis **ground**.
2. Connect **blue/black** wire with **inline fuse** to the positive (+) or “hot” side of the 12 VDC or 24 VDC ignition power source. **DO NOT connect directly to battery.**
3. Connect the **10-pin plug** of the wiring harness to the ComLink.
4. Connect both the **2-pin** and the **4-pin** plugs of the wiring harness to the display.
5. When using an alarm, connect the **alarm output wire and the ground return wire** to the desired device (buzzer, horn, light, etc.). Ensure that any unused alarm wires are electrically insulated.

B. Secure Cables and Reassemble the Dash

1. Coil excess wires and harnesses and secure using nylon cable ties.
2. Tie wires and sensor assemblies to other secured harnesses, to prevent damage due to vibration.
3. Reassemble the dash assembly. Ensure all connections are tight.
4. Turn the ignition key **ON** and perform a final system check.

NOTE

The scale will only display accurate weights after it has been completely calibrated to a certified platform scale, by entering empty and loaded axle weights into the Air-Weigh Scale. *Enter empty weights only when the vehicle is empty! Enter loaded weights only when the vehicle is loaded!*

See LoadMaxx Calibration and Operations Manual, p/n 901-0114-000, for complete instructions.

NOTE

If the scale system includes the optional printer, the printer wiring is made up of three cables; see Printer Installation Instructions, p/n 901-0105-000, in your Printer Kit package.

One cable permanently connects to the Printer Port on the ComLink and to a connector hole in the dash. Another cable connects to the printer. The third cable joins these two together. The 2-part cable assembly between the printer and the dash is designed for easily disconnecting from the dash. Store the printer and its cables in a clean, dry place when not in use.

V. INSTALLING AIR SUSPENSION SENSOR(S)

1. Air Line Installation for each leveling valve

A. Route Air Line from Air Suspension

Follow the same instructions for air line and sensor installation for both drive and steer air suspensions. The parts in this section's instructions are listed in **Table 4**.

If an Air Suspension Gauge for the suspension already exists in dash, skip to **V.2, Installing Sensor(s)**. Otherwise, continue with this procedure.

1. Route a ¼-inch air line from the airbag suspension to the dash.

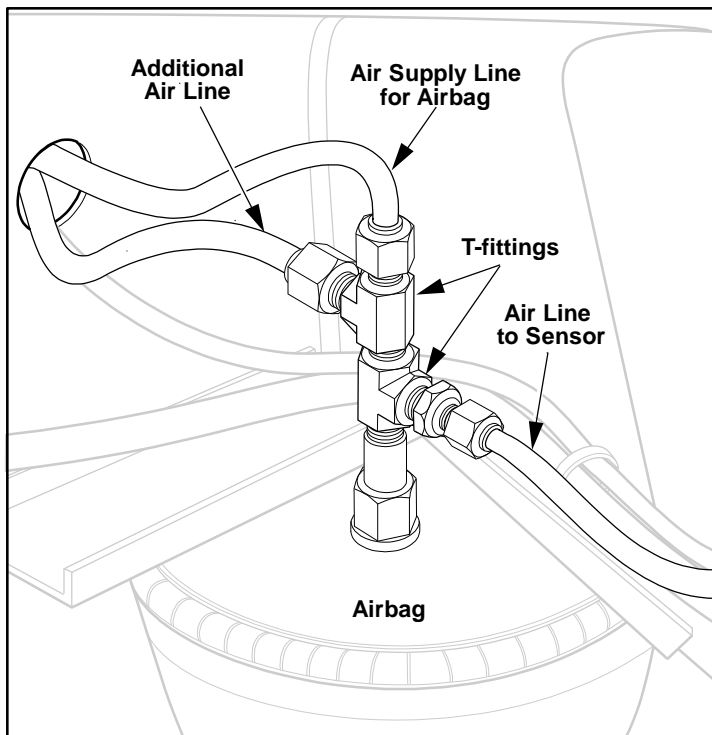

Figure 3. Airbag and Air Line Connections

2. Use a ¼-inch straight street-T at the top of a convenient drive axle suspension air bag to access

air pressure. If you choose to connect in the middle of an existing air line between two air bags, thoroughly remove any paint on the air line and wipe clean before cutting the air line.

3. Route the air line along with other air lines and cables into the dash. Loosely connect the air line to the other air lines and cable with cable ties to prevent it from being damaged.

NOTE

Avoid connecting on the air bag's supply line.

B. Routing Air line for Dedicated Tractor / Trailer Scale

The parts in this section's instructions are listed in Table 4. If Trailer Suspension gauge already exists in dash, skip to V.2, Installing Sensor(s).

Table 4. Air Line and Disconnect Kit BOMs

Bill of Materials for Suspension Air Line Kit, p/n 010-0023-000		
PART NUMBER	DESCRIPTION	QTY
145-4552-001	NYLON TIE, 7", T-50, NYLON, BLK	25
150-4081-000	¼ NPT STREET TEE, DOT, BRASS	1
150-4083-000	DOT COMPRESSION, ¼ NPT, MALE, BRASS	1
380-0046-000	40' X ¼" SAE J844 DOT TUBING	1
BOM for Trailer-Direct Disconnect Kit, p/n 010-0028-002		
145-4552-001	NYLON TIE, 7", T-50, NYLON, BLK	25
150-4081-000	¼ NPT STREET TEE, DOT, BRASS	1
150-4083-000	DOT COMPRESSION, ¼ NPT, MALE, BRASS	3
150-4091-000	FITTING, BRASS, QUICK COUPLER, MALE	1

150-4092-000	FITTING, BRASS, ADAPTER PLUG,FEMALE	1
152-0001-000	BULKHEAD FITTING, 1/4" NPT	2
380-0050-000	100' X 1/4" SAE J844 DOT TUBING	1
380-0053-000	AIR HOSE, COILED, 1/4" NPT X 2, 25'	1
901-0052-000	INSERT, AW5800, TRAILER-DIRECT	1

BOM for Two-Trailer-Direct Disconnect Kit, p/n 010-0029-002

145-4552-001	NYLON TIE, 7", T-50, NYLON, BLK	50
150-4081-000	1/4 NPT STREET TEE, DOT, BRASS	2
150-4083-000	DOT COMPRESSION, 1/4 NPT, MALE,BRASS	8
150-4091-000	FITTING, BRASS, QUICK COUPLER, MALE	3
150-4092-000	FITTING, BRASS, ADAPTER PLUG,FEMALE	3
152-0001-000	BULKHEAD FITTING, 1/4" NPT	6
380-0046-000	40' X 1/4" SAE J844 DOT TUBING	1
380-0050-000	100' X 1/4" SAE J844 DOT TUBING	2
380-0053-000	AIR HOSE, COILED, 1/4" NPT X 2, 25'	3
901-0065-000	INSERT, AW5800, TWO-TRAILERS-DIRECT	1

1. Remove existing air line connection from one trailer air bag.
2. Install street-T (p/n: 150-4081-000) into air bag.
3. Install fitting (p/n: 150-4083-000) into side of street-T and connect to air line (p/n: 380-0050-000).
4. Reinstall original air line and fitting connector to top of street-T.
5. Run air line (p/n: 380-0050-000) to front of trailer. Secure with cable ties.

6. Drill hole for trailer bulkhead fitting at a point near where existing airlines attach to trailer.
7. Install bulkhead fitting (p/n: 152-0001-000).
8. Cut air line to length and connect to rear side of bulkhead fitting. Use remaining air line in step 13.
9. Attach female quick-disconnect coupling (p/n: 150-4092-000) to face of bulkhead fitting.

NOTE

Female coupling MUST be connected to trailer air line to keep air in suspension system.

10. Connect end of coiled air line (p/n: 380-0053-000) with male quick disconnect coupling to female quick disconnect coupling (p/n: 150-4092-000). See **Figure 4**.

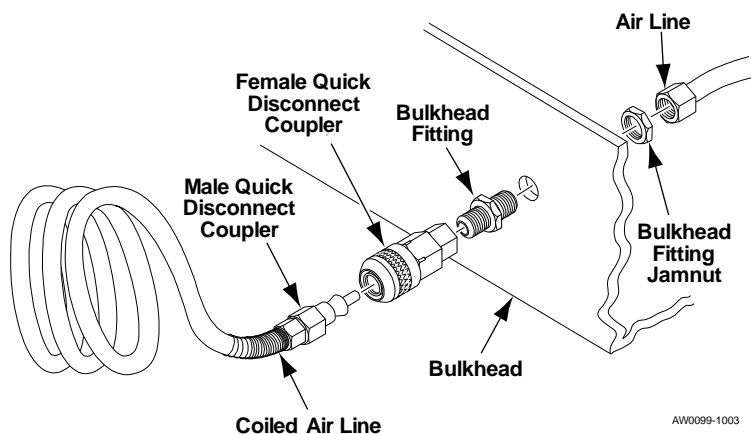

Figure 4. Installing Bulkhead Connector

11. Attach quick disconnect fitting (p/n: 150-4091-000) to one end of coiled air hose and couple to quick disconnect fitting (p/n: 150-4092-000) on front bulkhead of trailer. See **Figure 4**.

12. Drill hole in tractor bulkhead near where existing air lines attach to the tractor and install bulkhead fitting (p/n: 152-0001-000).
13. Connect the other end of the coiled air line (p/n: 380-0053-000) to the face of the bulkhead fitting.
14. Install brass fitting (p/n: 150-4083-000) into rear of bulkhead fitting. Run air line (380-0050-000) from brass fitting to under dash, close to ComLink mounting location. Secure with wire ties.
15. Connect open end of air line, near ComLink, to push-on fitting on end of Air Pressure Sensor.
16. Connect electrical cable from opposite end of air pressure sensor to appropriate port on ComLink. See **Table 5. Kit Configuration Sensor Assignment** to determine the appropriate port for the sensor connector.

2. Installing Sensor(s)



CAUTION

Avoid dropping the sensors. Dropping can cause the sensors to fail immediately or shorten their lifespan.

A. Installing Air Pressure Sensor (s)

There are two methods of installing the sensor connections to the suspension air line(s) under the dash. See **Figure 5. Connecting the Air Pressure Sensor**

1. Insert a T-fitting into an existing suspension air gauge.
2. Terminate the air line into the nickel plated brass fitting supplied by Air-Weigh.

The Air-Weigh kit includes fittings for terminating air lines of either of two diameters, ¼-inch and 5/32-inch. The customer will need to purchase additional fittings to insert

a T-fitting into an existing air line. Air-Weigh only supplies the connectors needed for a terminated connection.

1. Connect sensor to fitting and tighten. Using a torque wrench, set torque to approximately 25 ft-lbs.
2. Push end of air line into fitting and ensure connection is firmly secured.

NOTE

While the air line can be removed from the fitting by retracting the O-ring while gently pulling the air line out, repeated removal and replacement will weaken the seal.

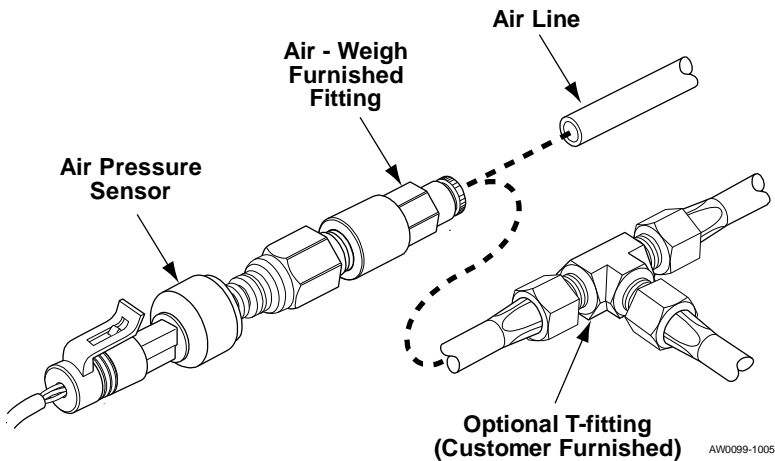

Figure 5. Connecting the Air Pressure Sensor

NOTE

Female coupling **MUST** be connected to trailer air line to keep air in the air bag suspension system.

B. Installing Scales with a steer axle Deflection Sensor

NOTE

When installing kits with configurations 5807, 5808, 5843, 5846, 5853, 5857 or 5878, which include steer axle deflection sensors, refer to p/n 901-0059-000, Steer Axle Deflection Sensor Kit Installation Guide, for installation instructions.

Table 5. Kit Configuration Sensor Assignment

Number See Kit Part Number for Model Number	Sensor Installed on this Suspension HCV = Height Control Valve	Sensor Type AP = Air Pressure Sensor DS = Deflection Sensor LC = Load Cell	ComLink Sensor Cable Input Jack
5800	Drive	AP	Sensor A
5801	Drive, Dual HCV's	AP, AP	Sensor A & B
5803	Drive, Hide Steer	AP	Sensor A
5805	Drive	AP	Sensor A
	Steer	AP	Sensor B
5806	Drive, Dual HCV's	AP, AP	Sensor A & B
	Steer	AP	Sensor C
5807	Drive	AP	Sensor A
	Steer	DS	Sensor B
5808	Drive, Dual HCV's	AP, AP	Sensor A & B
	Steer	DS	Sensor C
5815	Drive, Dual HCV's	AP, AP	Sensor A & B
	Steer, Dual HCV's	AP, AP	Sensor C & D
5816	Drive, Dual HCV's, Hide Steer	AP, AP	Sensor A & B
5821	Drive	AP	Sensor A
	<not used>	N/A	Sensor B
	Steer, Dual HCV's	AP, AP	Sensor C & D
5826	Drive	AP	Sensor A
	Steer	AP	Sensor B
5827	Drive, Dual HCV's	AP, AP	Sensor A & B
	Steer	AP	Sensor C
5835	Drive	AP	Sensor A
	Steer	DS	Sensor B
	Lift	AP	Sensor C
5836	Drive, Dual HCV's	AP, AP	Sensor A & B
	Steer	DS	Sensor C
	Lift	AP	Sensor D
5838	Drive	AP	Sensor A
	Steer	AP	Sensor B
	Lift	AP	Sensor C
Trailer Direct 5840	Drive, Hide Steer	AP	Sensor A
	Trailer, Trailer – B-Train	AP, AP	Sensor B & C
Trailer Direct 5841	Drive	AP	Sensor A
	Trailer, Trailer – B-Train	AP, AP	Sensor B & C

Number See Kit Part Number for Model Number	Sensor Installed on this Suspension HCV = Height Control Valve	Sensor Type AP = Air Pressure Sensor DS = Deflection Sensor LC = Load Cell	ComLink Sensor Cable Input Jack
Trailer Direct 5842	Drive	AP	Sensor A
	Steer	AP	Sensor B
	Trailer, Trailer – B-Train	AP, AP	Sensor C & D
Trailer Direct 5843	Drive	AP	Sensor A
	Steer	DS	Sensor B
	Trailer, Trailer – B-Train	AP, AP	Sensor C & D
Trailer Direct 5844	Drive, Dual HCV's	AP, AP	Sensor A & B
	Trailer, Trailer – B-Train	AP, AP	Sensor C & D
Trailer Direct 5845	Drive, Dual HCV's	AP, AP	Sensor A & B
	Trailer, Trailer – B-Train	AP, AP	Sensor C & D
Trailer Direct 5846	Drive	LC	Sensor A
	Steer	DS	Sensor B
	Trailer, Trailer – B-Train	AP, AP	Sensor C & D
Trailer Direct 5850	Drive, Hide Steer	AP	Sensor A
	Trailer	AP	Sensor B
Trailer Direct 5851	Drive	AP	Sensor A
	Trailer	AP	Sensor B
Trailer Direct 5852	Drive	AP	Sensor A
	Steer	AP	Sensor B
	Trailer	AP	Sensor C
Trailer Direct 5853	Drive	AP	Sensor A
	Steer	DS	Sensor B
	Trailer	AP	Sensor C
Trailer Direct 5854	Drive, Dual HCV's, Hide Steer	AP, AP	Sensor A & B
	Trailer	AP	Sensor C
Trailer Direct 5855	Drive, Dual HCV's	AP, AP	Sensor A & B
	Trailer	AP	Sensor C
Trailer Direct 5856	Drive, Dual HCV's	AP, AP	Sensor A & B
	Steer	AP	Sensor C
	Trailer	AP	Sensor D
Trailer Direct 5857	Drive, Dual HCV's	AP, AP	Sensor A & B
	Steer	DS	Sensor C
	Trailer	AP	Sensor D
Trailer Direct 5860	Drive, Dual HCV's	AP, AP	Sensor A & B
	Trailer, Dual HCV's	AP, AP	Sensor C & D
5878 No FSK	Drive, Dual HCV's	AP, AP	Sensor A & B
	Steer	DS	Sensor C

VI. FOR FURTHER INFORMATION

Included in the Scale Kit:

901-0039-000 – Card, Sensor Configuration, AW5800, BOM Level

901-0041-000 – Card, Quickstart, AW5800, Generic

901-0054-000 – Card, AW5800, Operations, Calibration

901-0114-000 – Manual, LoadMaxx, Operations, Tractor, Air Drive

Included in the Printer Kit:

901-0105-000 – Air-Weigh Date Time Printer Installation Instructions

Included in the Trailer-Direct or Two-Trailers-Direct Disconnect Kit:

901-0052-000 – Insert, AW5800, Trailer-Direct

901-0065-000 – Insert, AW5800, Two-Trailers-Direct

901-0100-000 – Insert, LoadMaxx, Install Guide

Available from Air-Weigh Support:

901-0077-000 – Operating Voltages and Current for 5800 Series Products

901-0117-000 – Application Note, LoadMaxx, Calibrating The Lift Axle

VII. LIMITED WARRANTY

For product failures due to material or manufacturing defects, Air-Weigh will replace or repair all components for up to 3 years from shipment date to the end-user Air-Weigh customer. These three-year components include: Displays, ComLinks, Air Sensors, Power Cables, Air Sensor Assemblies, Air Sensor Harnesses, and all other associated external components. Air-Weigh assumes no responsibility for administering warranty claims directly with any third party end users. The responsibility of Air-Weigh under this warranty is limited to the repair, replacement, or credit of the defective part or assembly.

This warranty does not cover incidental or consequential damage to persons or property caused by use, abuse, misuse, or failure to comply with installation or operating instructions. This limited warranty does not apply to any product that has failed due to accident, abuse, alteration, installation not consistent with printed installation instructions, improper maintenance, improper operation, or as a result of system integration or installation not explicitly approved in writing by Air-Weigh.

Air-Weigh and its resellers shall have no responsibility or liability for damages if the purchaser or any other person alters the vehicle incorporating Air-Weigh products. This limited warranty shall not apply to any product that has been repaired or altered by anyone not employed by Air-Weigh or not operated in accordance with the manufacturer's printed material delivered with this product.

Air-Weigh hereby expressly disclaims any and all implied warranties of any type, kind of nature whatsoever, particularly any implied warranty of merchantability or fitness for a particular purpose not expressly stated by Air-Weigh in its printed material delivered with its products.

Some states do not allow the exclusion or limitation of incidental or consequential damages. If such laws apply, the limitations or exclusions contained in the terms and conditions of this Warranty may not apply. This warranty gives you specific legal rights and you may also have other rights, which vary state to state.

May be covered by U.S. Patent Nos. 4832141, 5478974, 5780782, 7478001, Foreign Patent Nos. 623635, 1305191, 260494, 677998, 2122766, 625697

Copyright © 2004, 2006, 2007, 2008, 2009, 2010 by Hi-Tech Transport Electronics, Inc. All rights reserved. Air-Weigh®, ComLink™, WireLink™, Weight Gauge™, and Hi-Tech Transport Electronics are registered trademarks of Hi-Tech Transport Electronics, Incorporated. Other brand, product, or service names listed in this document are the trademarks or registered trademarks of their respective holders. Information contained in this literature was accurate at time of publication. Product changes may have been made after copyright dates that are not reflected.

1. Procedure for Warranty Claims

1. In the event Air-Weigh requests to examine product prior to disposition, OR for repairs or replacements, Air-Weigh requires a Return Material Authorization (RMA) number to be issued before the item is returned. Contact Customer Support Department at (888) 459-3247 for an RMA number. Please reference this RMA number in all correspondence.
2. Claimed items shall be shipped freight pre-paid to: Air-Weigh, Customer Support Department, 1730 Willow Creek Circle, Eugene, Oregon 97402, USA. The Air-Weigh RMA number shall appear on the outside of the return packaging.
3. Air-Weigh shall examine returned material within 30 days after receipt, or sooner if mutually agreed upon. If Air-Weigh determines that the part or assembly was defective in material or workmanship and within the warranty period, Air-Weigh will repair or replace the part or assembly and return freight pre-paid. In the event Air-Weigh determines that the part or assembly cannot be repaired or replaced and is within the warranty period, a credit not to exceed the purchase price will be issued to the Air-Weigh customer.
4. Air-Weigh Accounting will process a credit memo and notify the Air-Weigh customer by email or fax. The Air-Weigh customer will process a corresponding debit memo and notify Air-Weigh Accounting.
5. If the part or assembly received by Air-Weigh does not meet the requirements of the warranty program set forth above, at the Air-Weigh customer's request the part or assembly will either be discarded, returned freight collect, or repaired or replaced at the Air-Weigh customer's expense and returned freight collect.

Notes



1730 Willow Creek Circle • Eugene, Oregon 97402-9152 USA
P.O.Box 24308 • Eugene, Oregon 97402-0437 USA

Telephone (541) 343-7884 • Order Desk (888) 459-3444
Customer Support (888) 459-3247 • FAX (541) 431-3121

Hours of Operation: Mon-Fri, 7am – 5pm, Pacific Time
www.Air-Weigh.com