



LANDSCAPE

Kestrel Evo 'S' VFA

The ever popular VFA variable forward arm is now available in the compact yet powerful Kestrel 'S' range.

Features include integral road lighting, tubular 3 point linkage and power slew with hydraulic breakout.

Key Features

- 16'5" reach
- Parallel arm option
- Power slew
- Choice of flails, heads and cutter bars
- Debris blower option



Proven Landscape Technology

Visit: www.bomford-turner.com

Kestrel Evo 'S' VFA	5.0m (16'5")
Tractor requirements	
Minimum horse power	50hp
Minimum weight	6614lbs
Base unit mounting options	
Front mount	—
Mid-mount	—
Rear mount	●
Three point linkage (CAT II)	●
Axle bracket	—
Sub Frame	—
Yoke	—
Overall machine parameters	
Machine weight with head and oil	2601lbs
Capacity of oil tank	42.3USG
Weight of machine with oil but without head	2072lbs
Controls	
Cable Control (CC)	●
Low pressure hydraulics (LPH)	○
Electronic proportional control (EPP)	○
Intelligent control system (ICS)	—
Cable rotor reverse	●
Electronic rotor reverse	—
Hydraulic System	
System capability	54hp
Pump flow rate	19.4USG
Pump type (Gear / Piston / Helical)	Gear
Pump arrangement (Twin / Tandem Inline)	Twin
Independent hydraulics	●
Oil cooler	○
Arm features and main frame	
Forward arm	3'11"
Telescopic arm	—
Telescopic arm stroke	—
Power slew	●
Power slew angle	94°
Gravity breakout protection	—
Hydraulic breakout protection	●
Arm float - manual operation	○
Arm float - electronic operation	○
Head float - manual operation	●
Head float - electronic operation	○
Left hand cutting	○
Right hand cutting	○
Left and right hand cutting	—
Arm attachments available	
Variable track bracket (VTB)	—
Sheartrim cutter bar	○
Pro-Saw	○
Ditch cleaner	—
Rotary head	—
Accessories	
Road lights	●
Debris blower	○
Warning arrow - Magnetic	○
Cab guard kit	●
Cutting heads (For Flail compatibility see pg 86)	
1.2m Pro-Trim with 115/150mm roller	○
1.2m Pro-Trim ISMP with 115/150mm roller	○
1.5m Pro-Trim with 115/150mm roller	○

Working Reach

Head used for calcs: **1.2 Pro-Trim**

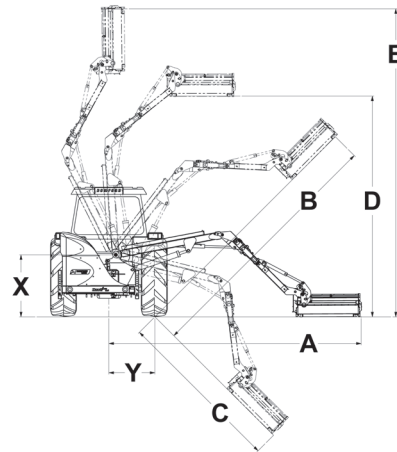

Side Reach Kestrel Evo 'S' VFA 5.0 (16'5")

A	16'8"
B	15'9"
C	16'2"
D	14'9"
E	18'7"
X	4'5"
Y	3'4"

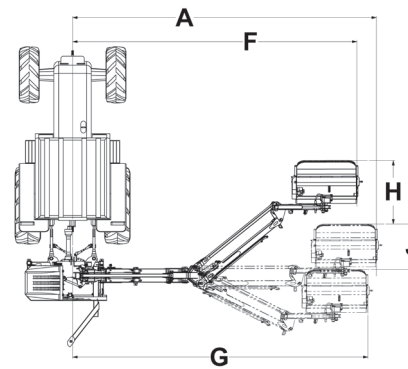

Forward Reach Kestrel Evo 'S' VFA 5.0 (16'5")

A	16'8"
F	17'8"
G	16'4"
H	3'11"
J	1'10"

Available from:



Want to know more about the Kestrel Evo 'S' VFA?

Scan the QR code to the left with a smart phone or tablet and compatible app to instantly view the page.

Alternatively visit: <http://www.bomford-turner.com/landscape/arm-mowers/kestrel-evo-s-vfa/>



Visit: www.bomford-turner.com

Tel **+44 (0) 1789 773383**

Fax **+44 (0) 1789 773238**

E-mail info@bomford-turner.com

Follow us
online on

