



HAWK EVO VFA



19'8" REACH

The new Bomford Hawk VFA (Variable Forward Arm) offers many advantages over conventional boom mowers.

The rear mounted machine is 3 point hitch mounted standard with axle mounting as an option, this enables the mower to be quickly removed/attached to free the tractor of other operations. Its variable forward arm feature where the tractor stands still and the head moves forward by 5' and backwards 2', a total traverse of over 7 feet. This gives a mid-mount head position alongside the operator, but can be positioned rearward for other operations. Enabling a transport position within the tractor width.

The Hawk VFA comes standard with independent hydraulic system providing cutting power to the head and superior arm control via a choice of controls including our ICS fully proportional fingertip control.



Upgrade options

Clockwise from top left:
Pro-Saw, Sheartrim, Rotary Head, Weed Brush, Ditcher



PRODUCT SPECIFICATION

| HAWK EVO VFA | |
|--|------------------------------|
| Minimum Horse Power (PTO) | 90hp |
| Minimum Tractor Weight | 10000lbs |
| Rear Mount | ● |
| Three Point Linkage (CAT II) | ● |
| Axle Bracket | ○ |
| Machine Weight with Head and Oil | 4268lbs |
| Capacity of Oil Tank | 66 US gal |
| Machine Weight with oil but without Head | 3696lbs |
| Cable Control (CC) | ○ |
| Electronic Proportional Control (EPP) | ○ |
| Intelligent Control System (ICS) | ○ |
| Low Pressure Hydraulics (LPH) | ○ |
| Cable Rotor Reverse | ○ |
| Electronic Rotor Reverse | ○ |
| Hydraulic System Capability | 74hp |
| Pump Flow Rate (cutting circuit) | 33 US gal |
| Pump Type | Gear |
| Pump Arrangement | Twin |
| Independent Hydraulics | ● |
| Oil Cooler | STD (on electronic controls) |
| Power Slew | ● |
| Power Slew Angle | 94° |
| Hydraulic Breakout | ● |
| Armfloat – Manual | ● |
| Armfloat – Electronic | ○ |
| Headfloat – Manual | ● |
| Headfloat – Electronic | ○ |
| Left Hand Cutting | ○ |
| Right Hand Cutting | ● |
| Cutterbar | ○ |
| Pro-Saw | ○ |
| Ditch Cleaner | ○ |
| Rotary Head | ○ |
| Road Lights | ○ |
| Debris Blower | ○ |
| Warning Arrow (Magnetic/Fixed) | ○ |
| Cab Guard Kit | ● |
| 4' Pro-Trim with 6" Roller | ○ |
| 5' Pro-Trim with 6" Roller | ○ |
| 4' Pro-Trim ISMP with 6" Roller | ○ |

● Standard ○ Optional — Not Available

WORKING REACH

| | |
|---|--------|
| A | 19'11" |
| B | 19'7" |
| C | 19'3" |
| D | 16'4" |
| E | 20'3" |
| X | 4'5" |
| Y | 4'2" |

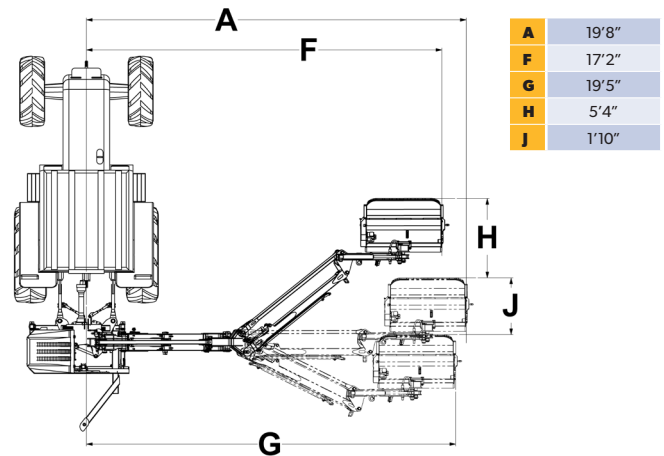
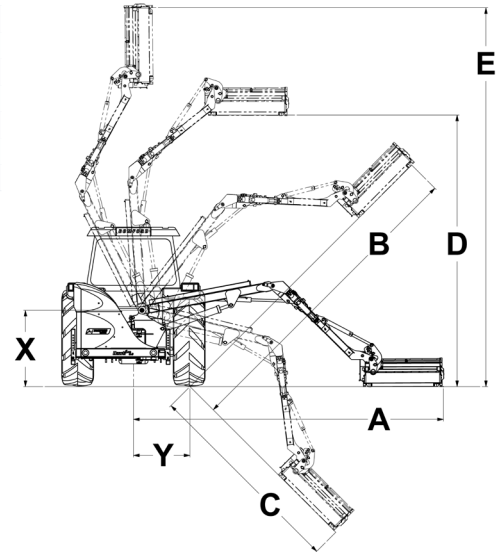

AVAILABLE FROM:



Tel **+44 (0) 1789 773383**
 Fax **+44 (0) 1789 773238**
 E-mail info@bomford-turner.com

Follow us



Website www.bomford-turner.com