

LED Post Top Area Light 60W/100W/150W



LED Post Top Area Light is designed to replace existing garden street light, yard light etc. There is 130lm/w high brightness. Photocell and dimmable function to save more energy. Durable chip and fade resistant powder coat finish are perfect for outdoor application. ETL/DLC listed with 5 years warranty.



LED Post Top Area Light

60W/100W/150W



Glass Lens
(Test data: 108° beam angle)



PC Lens
(Test data: 118° beam angle)

Features:

- * Suitable to diameter 60mm/80mm pole.
- * CREE LED 130lm/w high brightness.
- * Dusk to dawn Photocell function available.
- * Dimmable available.
- * IP65 waterproof rating for wet and damp location.
- * Quiet operation, no audible hum or noise.
- * Working environment in -30°C to 50°C.
- * DLC/ETL/CE/ROHS/LM79/LM80 for quality assurance and safety operation.
- * IES files are available.
- * 5 years warranty.



Details:

- Photocell Sensor



- Microwave Motion Sensor



- High brightness LED chips 130lm/w. LM79/LM80 Report.

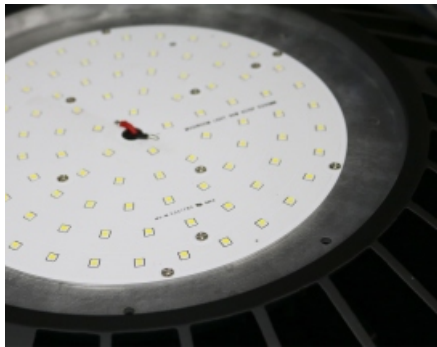

- The screw can adjust the hole size and fix with pole more closer and stable. Suitable to diameter 60mm/80mm pole.

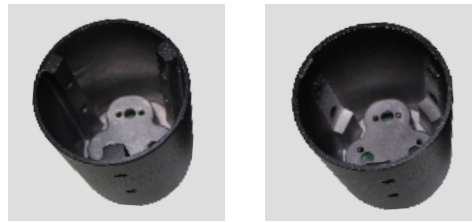

60mm pole

80mm pole

Beam Angle:

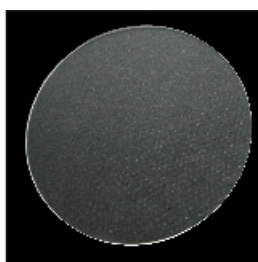

Glass Lens

(Test data: 108° beam angle)



PC Lens

(Test data: 118° beam angle)

Specifications:

| Model | ALC-LS-RMS-PT60W | ALC-LS-PT-100W | ALC-LS-RMS-PT-150W |
|--------------------|---------------------|----------------|--------------------|
| Wattage | 60W | 100W | 150W |
| Luminous Flux | 7800lm | 13000lm | 19500lm |
| Light Source Count | 90pcs | 140pcs | 210pcs |
| LED Brand | CREE LED | | |
| Color Temperature | 3000K~6500K | | |
| Input Voltage | AC100-277V, 50-60Hz | | |
| Beam Angle | 108 /118 Degree | | |
| CRI | Ra>80 | | |
| PF | >0.9 | | |
| Life Hours | 50,000 | | |
| IP Rating | IP65 | | |
| Dimension | φ 360*H520mm | | |
| Package (L*W*H) | 470*400*165 (mm) | | |
| N.W | 5.52kg | 5.56kg | 5.60kg |
| G.W | 5.78kg | 5.82kg | 5.86kg |

Photometry:

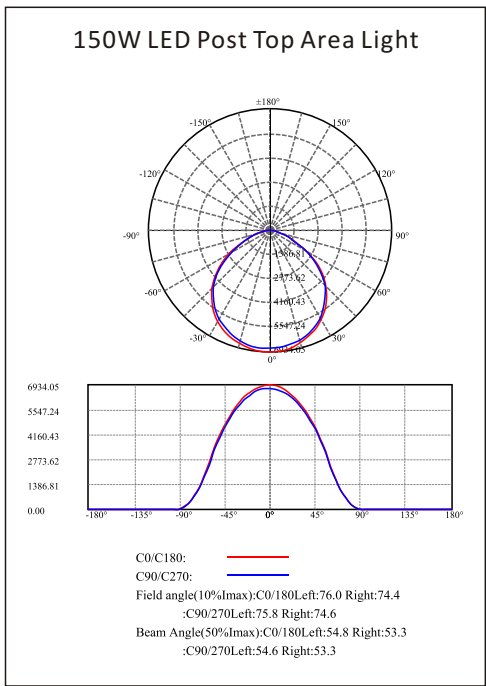
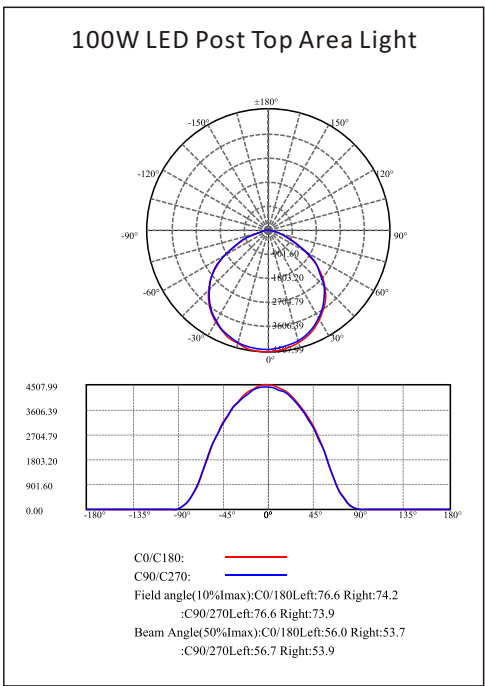
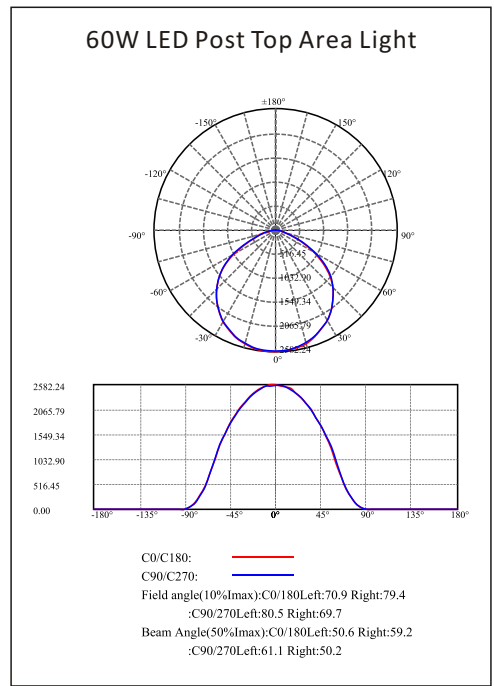

Dimension:

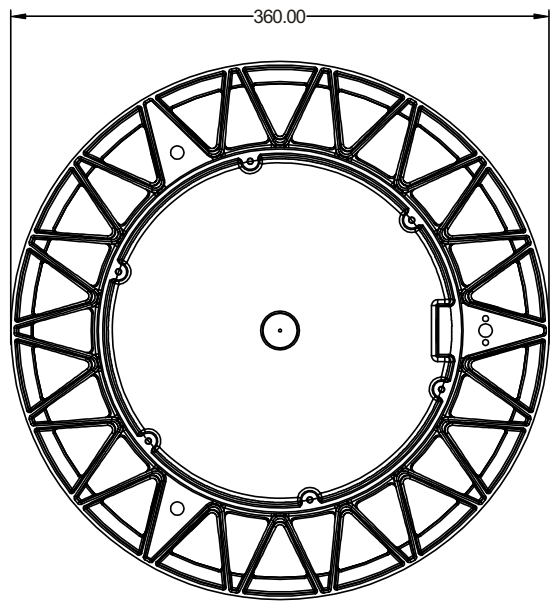
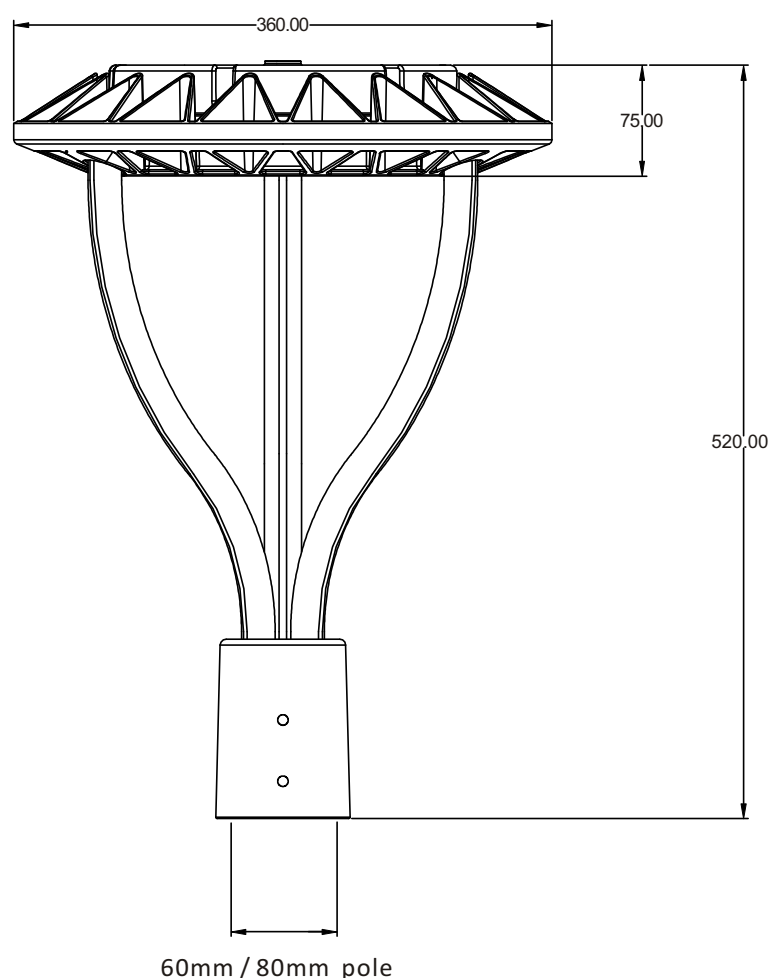

Packing:



Application:

Garage, parking lot, square, alley, back street, garden, yard etc.

