

**IBERIAN WESTERN HORSE ASSOCIATION  
CORPORATION BYLAWS**

**IWHA MISSION STATEMENT**

To promote the western attributes of the Andalusian, Lusitano and part bred Spanish horses and to provide an avenue to showcase their athletic abilities in western disciplines while protecting their welfare and heritage.

**ARTICLE I—Title, Objectives and Location**

**Section 1. Title**

The association will be known as the IBERIAN WESTERN HORSE ASSOCIATION (IWHA) and will be conducted as a not-for-profit association in accordance with the statutes of the State of Texas.

**Section 2. Objectives**

The purpose of the IWHA is to promote the western attributes of the Andalusian, Lusitano and part bred Spanish horses and to provide an avenue to showcase their athletic abilities in western disciplines. In addition, the IWHA will educate the membership and public as to the versatility of these breeds as well as to encourage youth to become involved with these horses in and out of the show ring.

**Section 3. Location**

The principal place of business shall vest in Montague County, Texas, however the membership, including officers, may be residents of any U.S. state or other country and business matters can be conducted at any place convenient to those officers and members participating.

**ARTICLE II—Membership**

**Section 1.**

Members of the IWHA shall be admitted, retained and expelled in accordance with rules set forth in these bylaws. Membership fees shall be determined by the Board and the general membership shall be notified of any increase in membership and/or registration fees at least 120 days prior to

said action taking place. All members in good standing shall be entitled to one (1) vote in those matters that are governed by a vote of the membership.

**Section 2.**

Membership shall be opened to any resident of any country, including youth. Youth members (under the age of 18 years) must have their membership signed by a parent or legal guardian. The Board of Directors has the exclusive right to refuse membership to any particular individual that they feel does not exhibit ‘*sprit de corps*’ and would not represent the organization in a good light

**Section 3.**

An annual meeting shall be held after the first full year of corporation. Special meetings may be held at the discretion of the Board of Directors. 20% of the membership in good standing needs to be present, in presence or proxy, for a motion to pass by vote.

**Section 4.**

Notice of at least 30 calendar days shall be given prior to any scheduled meeting. Notice can be written notice delivered by U.S. mail, email notice, and/or notice in a newsletter or other publication that is available to all membership.

**Section 5.**

Any Director or Officer can call the meeting to order and can preside over the meeting.

**ARTICLE III—Directors**

**Section 1.**

The business shall be managed by the Board of Directors. The Board shall consist of the founding members. Control of the IWHA will be under the President who can appoint, retain or expel the other Board Members. The founding President shall retain the position indefinitely at the time these bylaws are written. If the President steps down or becomes incapacitated in such a way that he cannot carry out the duties of his position, the remaining Board members will appoint the predecessor.

**Section 2.**

During the inaugural year, the Board of Directors will consist of a President, Secretary and Treasurer. With growth of the organization, the following positions may be added at the discretion of the Board: Vice President, Membership Secretary and Show Manager.

### **Section 3.**

Committees may be formed at the request of any member of the Board of Directors. Committee heads will be appointed by vote of the board and all members of a committee shall be a member in good standing.

### **Section 4.**

The Board of Directors will meet quarterly. All meetings can be held remotely.

### **Section 5.**

The President will reside over all meetings, both of the Board and of the membership. The President shall ensure that the bylaws, rules and regulations of the organization are followed.

### **Section 6.**

The treasurer will be the chief financial officer and should account for the financial condition of the IWHA and provide a budget 30 days before the start of the calendar year. Following each event, the treasurer shall provide the Board with a detailed report of costs, expenditures and profits within 30 days.

### **Section 7.**

The Secretary shall record by writing the minutes of every Board and/or membership meeting and post said minutes on the website for the general membership to access. The minutes shall be voted on at the next meeting.

## **ARTICLE IV—Amendments**

### **Section 1.**

The Board shall have the power to make, amend and repeal bylaws by majority vote.

### **Section 2.**

Members in good standing can submit proposals for bylaws and/or rule changes by December 1<sup>st</sup> of each calendar year to be considered at the first Board of Directors meeting of the next year. The proposal shall be in writing and submitted to each Board member in person, by U.S. mail or electronically for review.

## **ARTICLE V—Indemnity**

## **Section 1.**

The Board of Directors shall not be held liable for any actions that were made in good faith and believed to be in the best interest of the IWHA. The members of the Board shall not be held liable for any injury and/or death resulting from participation in any events held by the organization.

### **IWHA'S DISCLAIMER OF RESPONSIBILITY FOR SAFETY**

The Iberian Western Horse Association does not assume responsibility for safety of participants at the shows or other events it sanctions. Exhibitors and attendees undertake the assumption of risk when participating or spectating any equestrian activities including, shows, clinics and other events. Participants in equine activities expressly assume the risk of and legal responsibility for an injury, loss or damage to person or property which result from the participation in equestrian activities.

### **Humane Treatment**

The welfare of the Iberian Horses and cattle exhibited in IWHA-approved events is safeguarded in comprehensive rules throughout this Official Handbook of Rules & Regulations that provide for their well-being. The Board has the right and responsibility to ensure the well-being of the animals and can take action including, but not limited to, investigation, prosecution, suspension of privileges and/or fines being levied - on all cases where substantial evidence existed of violations of IWHA and other recognized governing equestrian bodies' animal welfare rules.

# Iberian Western Horse Association

## Rules and Regulations

### General Rules

#### G1 Membership

Upon receipt of the required fees and approval by the Board of Directors (Board), membership into the IWHA will be effective immediately. The membership fees will be waived for the inaugural year of 2026.

Single membership comes with one vote in those matters voted on by membership.

While in good standing, all members have equal rights, interests and responsibilities with respect to the IWHA. They shall obey and be bound by all bylaws, rules and regulations and decisions or actions of the Board of Directors. They have the right to vote by personal or proxy attendance at membership meetings. They have the right to be selected by the board as a head or member of a committee or to a created position on the Board “Membership in good standing” means an individual or other legal entity who has paid the membership fee, is approved by the Board, is not under current suspension by the Board or does not owe a delinquent financial obligation to IWHA for fees or other account payable for which written notice of suspension of membership or participation privileges has been sent.

**G1A** Every member by joining the IWHA, filing registration applications or other documents with IWHA or participating in IWHA-approved events, does thereby agree:

If unsuccessful in an attempt to overturn IWHA decisions, actions, rules or regulations, to reimburse IWHA for its reasonable attorney’s fees, court costs and other expenses in defense of such suit, and

He/she will not commence any action, whether in law or equity, against IWHA in any courts Federal or State in the U.S. or other countries.

**G1B** Youth membership allows boys and girls under the age of 18, as determined by January 1 of each year, the privileges of membership at no cost. Youth may participate in youth, amateur and Open divisions but do not have the privilege to vote at membership meetings or hold office. Youth memberships must be cosigned by a parent or legal guardian.

As a condition for the issuance of youth membership, the applicant and/or the family member who actually owns the horse with which the youth will participate, agrees to provide, upon request, such documentation or other proof as requested by IWHA to support the representations of sole economic ownership of the horse or horses exhibited by the youth in youth events, and other criteria set forth above. Failure to promptly

furnish such documentation upon request may be cause for immediate termination of youth membership and be grounds for possible disciplinary action by the Board of Directors.

International youth members may exhibit a non-owned, non-leased horse in regular youth division classes. Although a youth may show a non-owned horse in the youth division, doing so could violate AMATEUR ELIGIBILITY.

**G1C** Amateur membership is for individuals otherwise qualifying for such membership under the rules of IWHA's amateur division, which allows the individual to participate in the amateur division, and, in addition, all of the privileges of an individual IWHA membership, including privilege to participate in IWHA's open division and other IWHA activities that require individual membership.

Amateur membership cards will be issued by IWHA only upon application and approval of the applicant by the Board. Applications shall be truthful in each and every detail. Submitting an application containing untrue statements shall subject the applicant to possible disciplinary action or suspension from participation privileges in IWHA events and/or suspension of membership. By submitting an application, applicant agrees to abide by IAWH amateur rules contained in this rulebook.

An individual, who, for any reason, becomes ineligible for amateur membership, shall promptly return the amateur membership card to IWHA. Remaining months of membership for an amateur membership that is revoked may be transferred to regular IAWH membership and a membership card issued to expire the same date as the original amateur membership card.

Applicant must be 18 years of age on or before January 1 of the year of application and no longer eligible to compete in youth classes.

To claim amateur status, an individual must meet the following criteria currently, and for the prior three years to application:

An amateur may not have shown, judged, trained or assisted in training a horse for remuneration, monetary or otherwise, either directly or indirectly. Payment of entry fees and/or expenses by anyone other than the amateur, the amateur's "Immediate Family" as defined herein or an amateur's collegiate team and/or nationally sponsored team (team demonstrations, exhibitions or international competitions only) shall be considered remuneration;

An amateur may not have instructed another person in riding, driving, training or showing a horse for remuneration, monetary or otherwise, either directly or indirectly.

An amateur may not have shown, trained or assisted in the training of a horse for which an immediate family member accepts remuneration, monetary or otherwise, either directly or indirectly, for such services.

An amateur may not have held credentials of horse show judge for any equine organization;

An amateur may not have held membership accreditation with the Professional Rodeo Cowboys Association, Women's Professional Rodeo Association, International Professional Rodeo Association, or have been rated as a #7 or above in the Ranch Sorting National Championships or a #7 in the United State Team Penning Association (ratings effective as of the first of each August or when new rankings are released by the associations) for those events or classes which are the same events or classes in which the individual competes, or desires to compete.

Notwithstanding the above, an individual who is 65 years of age or older and who was previously ineligible as outlined above is eligible to immediately apply for amateur membership so long as he/ she meets all other amateur eligibility requirements and relinquishes his/her horse show judging credentials.

Amateurs may appear in advertisements and/or endorse products or services. Remuneration, direct or indirect, may be received for these activities.

As a condition for the issuance of amateur membership, the applicant, and/or the family member who actually owns the horse with which the amateur will participate, agrees to provide, upon request, such documentation or other proof as requested by IWHA to support the representations of sole economic ownership of the horse or horses exhibited by the amateur in amateur or open events, and the other criterion set forth above. Failure to promptly furnish such documentation upon request may be cause for immediate termination of amateur membership and be grounds for possible disciplinary action by the Board of Directors.

To become eligible for amateur membership, or become eligible for reinstatement to amateur membership, the individual must wait a period of three years from the date of the last incident which rendered the individual ineligible, except as permitted by for individuals 65 years of age or older.

If a record owner (1) leases a horse for breeding purposes only and (2) retains sole right of competing with the horse, such record owner may exhibit the horse in open or amateur IWHA classes.

Upon revocation of amateur membership because of ineligibility, all earned amateur points from time of violation of eligibility rules shall be revoked.

## **G2. Rules**

**G2A** Every member of the Iberian Western Horse Association or owner of a horse registered with, is charged with notice of all rules and regulations published in the current Official Handbook which is available online at *iberianwesternhorseassociation.com*

**G2B** Additional to notice provided by the official handbook, members have the duty to remain current with all the rules, regulations and policies governing IWHA events and programs, which may be amended at any time. Although ample time is usually given regarding any changes, sometimes immediate changes need to be implemented and these changes will be published on the official website, *iberianwesternhorseassociation.com*.

## **REGISTRATION**

### **R1 Registration Book**

The official Registration Book of the Iberian Western Horse Association consists of horses issued registration certificates based upon their breed and parentage. The Registration Certificate carries the requirement that the registered horse shall be subject to and bound by the Rules and Regulations of the Iberian Western Horse Association.

**R1A** Payment is required at the time of processing and payable in U.S. funds only. Payment is by digital means through the official website, *iberianwesternhorseassociation.com*.

**R1B** An individual must be a member of the Iberian Western Horse Association at the time of registering a horse or must submit an application for membership at the time of requesting registration. Through the payment of a membership fee, an individual acknowledges that membership is voluntary and agrees to be bound by all terms and conditions provided in Rules and Regulations of the IWHA.

**R1C** A required form must be properly completed in its entirety, which included photographs, and signatures provided as requested.

### **R2 Assignment of Burden of Persuasion for Registration Eligibility**

In all proceedings concerned with or affecting the registrations in IWHA and in all disciplinary actions, the burden of resolving any doubt

as to the true parentage, identification of a horse or qualification for registration shall be upon the applicant, owner, lessee or other member or members involved. The determination, decision and action of the Board of Directors upon all such questions shall be final and binding upon all parties. As the above specified party or parties have the burden of persuasion, by failure to present relevant evidence concerning such questions to the Board they shall be deemed to have waived their right to later present such evidence.

**R2A** Genetic tests may be required as the Board determines, including, but not limited to, questions of true parentage or identification of horses. Taking into consideration the results of such tests, and other information as may be available, the Board may authorize such corrections in the records as may be determined necessary or appropriate.

**R2B** The certificate evidencing registration is issued on the following condition, which shall be printed on the face thereof: “This certificate is issued in reliance on the written application signed and attested by the individual specified by IWHA rules; and upon the express condition that IWHA has the privilege to correct and/or cancel the certificate for cause under its rules and regulations.”

### **R3** Breed Limitations

Registration acceptance into the Iberian Western Horse Association is limited to horses of the Andalusian (Pura Raza Espanola) and Lusitano breeds and those horses that are part-bred of the aforementioned. Examples of crossed part-bred horses are Azteca (Quarter Horse), Hispano-Arabe (Arabian), Spanish Norman (Percheon), Warlander (Fresian), Iberian Warmblood (Thoroughbred, Warmblood) and others. Azteca horses may not have more than 75% Quarter Horse in their genetic makeup.

### **R4** Recognized Outcross Registries

Registration with the following organizations are recognized as acceptable proof of breeding and will be accepted as proof of an acceptable breed when registering a horse with IWHA:

ANCCE  
US P.R.E (United States Representative for ANCCE)  
Association for the Foundation Andalusian Horse  
International Andalusian and Lusitano Horse Association  
The Foundation for the Pure Spanish Horse  
U S Lusitano Association  
ABPS Brazil (Associacao Brasileira de Criadores do Cavol Puro Sangue Lusitano)  
APSL Portugal (Associacao Portuguesa do Cavalo Puro Sangue Lusitano)  
AMCCRA (Asociacion Mexican de Criadores de Calballos de Raza Azteca)

American Azteca Horse International Association  
International Warlander Society and Registry  
Iberian Warmblood Registry International  
Spanish-Norman Horse Registry

#### **R5 Unregistered Horses**

Horses that do not currently hold registration papers with another registry can be registered with the IWHA providing that proof of parentage is provided. One parent must be a full bred Andalusian or Lusitano. Accepted proof of parentage can be provided via a breeder's certificate that has been signed and notarized and/or DNA analysis proving the horse is an offspring of a pure-bred parent. The burden of proof lies within the individual requesting registration and all expense related to such proof is vested with the applicant.

#### **R6 Photographs**

**R6A** Four (4) photographs must be included with the registration:

Front of horse with horse facing forward and front feet and ears visible

Each side of horse with horse facing forward and all four feet visible

Rear of horse with feet visible

Additional photographs of unusual markings are recommended. If a person is assisting in holding the horse, he or she should not be visible in the photograph. Be aware that dark horses photograph better on a light background and dark horses photograph better on a lighter one. Ensure that the horse is clean and is not wearing anything other than a halter. Mane and tail should be in a natural state.

**R6B** The Board reserves the right to choose the photograph to be included on the registration certificate.

**R7** A horse's name can only be changed upon new ownership of the horse. Proof of new ownership, in the form of a transfer of owner certificate, must be provided before a new registration certificate can be issued. The original certificate must be provided or the original owner must apply for a duplicate certificate.

**R8** A replacement certificate can be issued when the original certificate still exists but has been defaced. The original certificate must be provided before a replacement certificate is issued.

**R9** A duplicate certificate can be issued when the original has been lost or destroyed. Proof of ownership and identification of the horse must be provided before a duplicate certificate is issued.

**R10** When ownership of a horse has been transferred, a new registration certificate must be issued. Proof of ownership, in the form of a transfer of owner certificate, must be submitted before the new registration certificate can be issued. New photographs are also required at the time of registration.

**R11** When a previously registered stallion is gelded, notification must be made immediately to IWHA so that the registration papers reflect this. New registration papers will be provided to the owner according to the fee schedule.

## **SHOW RULES**

**S1** IWHA reserves the right to determine the number and location of shows per calendar year. All classes shall be open to all members in good standing that meet the age, ownership and eligibility requirement of each class.

**S1A** All participants, horses and owners/lessees of horses must hold a current, valid membership in the association

**S1B** Shows may be classified as breed, Regional, National or World

**S1C** The horse must have been entered in the class prior to the start of the class.

**S1D** A horse entered in the wrong class may be transferred to the correct class after the judging program has been printed

**S1C** Any exhibitor withdrawing from a show or class after entering shall forfeit any entry and other fees as well as all go-round monies which may be credited to him at the time of withdrawal. An exception is a vet's letter stating that the horse has a serious injury or illness that prevents the horse from competing.

**S2** Entry fees will be charged and will be uniform to all exhibitors in the class and must be paid in full with registration, not paid for by a third party or another contestant.

**S3** Exhibitors are expected to conform to all class rules from the time they enter the show arena until they exit the show arena.

**S4** Every horse at the competition shall, at all times, be treated humanely and with dignity, respect and compassion. This prohibition against inhumane treatment applies to IWHA members and nonmembers.

**S5** Show management is responsible for the condition of show premises, including, but not limited to, arena, exercise, and stall areas; the conduct and competence of show employees and other representatives; implementation of show activities and events; and all other aspects of the show.

**S5A** IWHA does not assume or accept duty or responsibility for safety at any show in regard to participants or any other third parties, or for the horses or other property thereof.

**S5B** As an express condition of the privilege to participate at an IWHA show or event, each owner, exhibitor, trainer and participant assumes the risks of participation, and releases and discharges IWHA, its officers, directors, representatives and employees from any and all liability, whenever or however arising, as to personal injury or property damage occurring as a result of participation in an event conducted by the show or on the show grounds thereof.

**S6** In regards to eligibility for participation, all approved classes at an IWHA show must be open to any horse owner meeting breed, age, ownership and eligibility requirements. Membership in IWHA is the only mandatory membership.

**S6A** Every person competing in an IWHA approved class must possess a current membership card, recorded solely in their name.

**S6B** Show management must inspect the membership card (can be digital) at any show the exhibitor has entered. If the exhibitor is a member but cannot produce the card (or a digital image) at the show, a replacement form must be completed and a new membership purchased at the show prior to entering. This fee is non-refundable.

**S6C** Any horse (stallion, mare or gelding) must have been issued an IWHA registration certificate to compete in any class.

**S6D** Any horse must have been issued a competition license.

**S6E** All horse must be at least three (3) years of age to participate in any class of any IWHA show, including performance halter as of January 1 of the calendar year.

**S6F** Geldings still listed as stallions according to IWHA records at the time the show results are processed will be disqualified.

**S6G** Stallions may not be exhibited by any exhibitor under the age of eighteen (18) years as determined by January 1 of the calendar year.

**S7** In addition to the requirements of the youth and amateur membership, any horse exhibited in the youth or amateur division must be solely owned by the contestant showing the horse or the contestant's immediate family. Amateur eligibility requirements also apply to the amateur exhibitor when showing in the open division. See exception for international youth members.

**S7A** Immediate family includes: father, mother, full or ½ sibling, in-laws, grandparents, aunt, uncle, niece, nephew, legal guardian, spouse, son, daughter and grandchild. Persons whose relationship is legally recognized as a domestic partnership or civil union under the laws of the jurisdiction in which they sought such relationship are considered immediate family. Separate legal entities, such as family corporations, trusts or partnerships, are also authorized owners of the amateur exhibitor's horse so long as all legal and equitable owners and beneficiaries of the legal entity are individuals specifically authorized by this rule.

**S7B** "Owned" means, in addition to other legitimate methods of acquiring ownership, the bona fide legal ownership obtained for adequate consideration in reasonable relationship with the actual market value of the horse. For example, a \$5 payment for a world championship quality horse does not meet the required character of required ownership for competition in the amateur or youth division. The relationship of the amateur or youth to the owner of the participating horse must be evidenced by submitting legal documentation (i.e. copies of

marriage and/or birth certificates) to the Board. Ownership must be evidenced by records and the registration certificate of such horse must show such person as the owner by proper endorsement of IWHA at the time the horse is entered in any youth or amateur show or class.

**S8** Amateurs and youth may show leased horses subject to the following:

Prior to the lessee (amateur or youth) showing the leased horse, IWHA must have received and recorded a showing lease form.

The lessee must be responsible for expenses associated with the care of the horse: boarding, feeding, routine farrier services and routine veterinary services;

During the term of the showing lease, only the lessee and lessee's immediate family may show the horse. The lessee's trainer may also show the horse during the term, but only in open division classes.

Immediate family includes: father, mother, full or ½ sibling, in-laws, grandparents, aunt, uncle, niece, nephew, legal guardian, spouse, son, daughter and grandchild. Persons whose relationship is legally recognized as a domestic partnership or civil union under the laws of the jurisdiction in which they sought such relationship are considered immediate family. Separate legal entities, such as family corporations, trusts or partnerships, are also authorized owners of the amateur exhibitor's horse so long as all legal and equitable owners and beneficiaries of the legal entity are individuals specifically authorized by this rule.

The term of the lease must be for a minimum one-year period, and the lease must be to an individual only. If the lease is terminated for any reason before the minimum one-year period, the horse can only be shown in the Open Division classes until one year has passed since the original start date of the lease.

Only one showing lease at a time per horse will be recognized

During the term of a showing lease, subsequent changes in ownership will not be recorded until the showing lease is terminated.

**S9** When exhibitor equipment failure causes a delay or a run to be discontinued, the judge will disqualify the entry.

**S9A** In any approved class, the judge shall have the authority to require the removal or alteration of any piece of equipment which is unsafe, or in his opinion, would tend to give a horse an unfair advantage or which he believes to be inhumane.

**S9B** Horses shall be shown in their natural splendor. Mane and tail extensions are forbidden. Hoof polish and hoof black is prohibited. Braiding and banding is not allowed. Trimming

inside ears is discouraged but not penalized. Trimming of excessive facial hair, fetlocks and bridle path is acceptable.

**S9C** The use of earplugs or cotton in the horse's ears is acceptable.

**S9D** Reruns will not be allowed in instances of equipment failure.

**S9E** Failure by exhibitor to wear correct number(s) in a visible manner shall result in disqualification. Visible numbers must be on both sides of the horse when showing in the under-saddle classes. In performance halter classes, the number should be placed on the back of the exhibitor.

**S9F** All inhumane/prohibited equipment as listed above is illegal for use at any time on the grounds at an IWHA event.

## **S10 EQUIPMENT.**

Any equipment and/or bit considered legal in an IWHA class may be used on any horse for training purposes on show grounds, whether or not the horse will be show in the class for which the equipment and/or it is legal; for example, equipment and/or bits legal for barrel racing classes may be used on horses of other disciplines for training on the show grounds.

**S10A** Hackamores shall be round in shape and constructed of uniform, smooth, braided rawhide or leather and have a non-metal flexible core. There must be at least 5½ inches on the underside of the noseband before any braided buttons. A hackamore must use a complete mecate rein, which must include a tie-rein. Absolutely no rigid material will be permitted under the jaws, regardless of how padded or covered. Horse hair bosals are prohibited. This rule does not refer to a mechanical hackamore.

**S10B** Snaffle bits in western performance classes mean the conventional O-ring, egg-butt or D-ring with a ring no larger than 4" in diameter (100 mm). The inside circumference of the ring must be free of rein, curb or headstall attachments which would provide leverage. The mouthpiece should be round, oval or egg-shaped, smooth and unwrapped metal. It may be inlaid, but smooth or latex-wrapped. The bars must be a minimum of 5/16" (8 mm) in diameter, measured one inch (25 mm) in from the cheek with a gradual decrease to center of the snaffle. The mouthpiece may be two or three pieces. A three-piece, connecting ring of 1 1/4" (32 mm) or less in diameter, or a connecting flat bar of 3/8" to 3/4"(10 mm to 20 mm) measured top to bottom, with a maximum length of 2" (50 mm), which lies flat in the horse's mouth, is acceptable. Optional leather strap attached below the reins on a snaffle bit is acceptable.

**S10C** Bits in western performance classes means the use of a curb bit that has a solid or broken mouthpiece, has shanks and acts with leverage. All curb bits must be free of mechanical device and should be considered a standard western bit. The description of a legal, standard western bit includes:

8 1/2" (215 mm) maximum length shank to be measured as indicated in the diagram on the previous page. Shanks may be fixed or loose;

concerning mouthpieces, bars must be round, oval or egg shaped, smooth and unwrapped metal of 5/16" to 3/4" (8 mm to 20 mm) in diameter, measured 1" (25 mm) from the cheek. However, wire on the sway bars (above the bars and attaching to the spade) of a traditional spade bit is acceptable. They may be inlaid, but must be smooth or latex wrapped. Nothing may protrude below the mouthpiece (bar), such as extensions or prongs, including upward prongs on solid mouthpieces. The mouthpiece may be two or three pieces. A three-piece, connecting ring of 1 1/4" (32 mm) or less in diameter, or a connecting flat bar of 3/8" to 3/4" (10mm to 20 mm) measured top to bottom with a maximum length of 2" (50 mm), which lies flat in the horse's mouth, is acceptable;

a linked mouthpiece with minimum 3/8" (10 mm) diameter that is smooth with movable links that are solidly attached to the shanks;

the port must be no higher than 3 1/2" (90 mm) maximum, with rollers and covers acceptable. Broken mouthpieces, halfbreeds and spades are standard;

donut and flat polo mouthpieces are not acceptable;

a curb bit must be used with a curb strap or curb chain properly attached so as to make contact with horse's chin;

slip or gag bit is permitted in speed events.

**S10D** Except for hackamore/snaffle bit classes or junior horses shown with hackamore/snaffle bit, only one hand may be used on the reins, and the hand must not be changed. The hand is to be around the reins; however, the index finger only is permitted between split reins. More than one finger may be between the reins of two-rein equipment. In trail, ranch trail and ranch riding it is permissible to change hands on the reins or carry the extension in the rein hand to work an obstacle. Violation of this rule is an automatic disqualification in all western performance classes, except VRH/RHC classes, and ranch riding and ranch trail where it is an automatic OP (off-pattern penalty.)

**S10E** Romal means an extension of braided or round material attached to closed reins. This extension shall be carried in the free hand with a 16-inch (40 cm) spacing between the reining hand and the free hand holding the romal. When using romal reins, the rider's hand shall be around the reins with the wrists kept straight and relaxed, the thumb on top and the fingers closed lightly around the reins. When using a romal, no fingers between the reins are allowed. The free hand may not be used to adjust the rider's length of rein in any reining class. During reining, the use of the free hand while holding the romal to alter the tension or length of the

reins from the bridle to the reining hand is considered to be the use of two hands and a score of 0 will be applied, with the exception of any place a horse is allowed to be completely stopped during a pattern. In all other classes, including the reined portion of working cow horse, boxing, and all VRH and RHC classes, the free hand may be used to adjust the rider's length of rein. In all western classes, excess rein(s) may be straightened or disentangled anytime during the class, provided the rider's free hand used to straighten or disentangle remains behind the rein hand. Any attempt to alter tension or length of the reins from bridle to rein hand is to be considered use of two hands and a penalty score of zero or disqualification will be applied. The romal shall not be used forward of the cinch or to signal or cue the horse in any way. Any infraction of this rule shall be penalized severely by the judge.

**S10F** Junior horses five (5) years and under as of January 1 of the calendar year) competing in western pleasure, reining, working cow horse, cutting, boxing, ranch riding, ranch trail, ranch pleasure that are shown with a hackamore or snaffle bit may be ridden with one or two hands on the reins. When riding with two hands on split reins, the tails of the reins must be crossed on the opposite side of the neck, reins may be held singularly or bridged, except in reining, working cow horse, box drive, boxing, ranch riding, ranch trail, where only one rein may be crossed over the neck and held with two hands. Closed reins (example mecate) may not be used with a snaffle bit, except in working cow horse, boxing, ranch riding, ranch pleasure and ranch trail, where a mecate is permitted. When using a snaffle bit in working cow horse, boxing, ranch riding, ranch trail or ranch pleasure, a leather or other woven material chin strap of any width is to be used and should be attached to the bit below the reins. No iron, chain, or other material is allowed. The chin strap can include metal buckles and/or keepers.

**S10G** In all western classes, horses will be shown in a western saddle and appropriate bridle, snaffle bit or hackamore for the duration of the class. A western stock saddle is a common type of saddle distinguished by a large noticeable fork on which there is some form of horn, a high cantle and large skirts. Silver equipment will not count over a good working outfit and is discouraged in ranch classes. Horses 5-years-old and younger may be shown in a snaffle bit, hackamore, curb bit, half-breed or spade bit. Horses 6-years-old and older may only be shown in a curb bit, half-breed or spade bit. Split reins or romal reins must be used on a curb bit except in speed events, team penning, ranch sorting, roping and cowboy mounted shooting where they are optional. When a curb bit is used, a curb strap or curb chain is required, but must meet the approval of the judge, be at least one half inch in width and lie flat against the jaw of the horse. Curb chains cannot be tied to the bit with string or cord. A broken strap or chain is not necessarily cause for disqualification.

## **S11 PROHIBITED EQUIPMENT**

Protective boots, leg wraps, and bandages are prohibited in western pleasure, ranch riding, ranch trail, and ranch pleasure.

Wire curb straps, regardless of how padded or covered, or curb strap with tacks/rivets.

Any curb strap narrower than one-half inch.

Chain, wire, or metal tie-down or bonnets are prohibited, regardless of how padded or wrapped.

Belly Bands; saw tooth bits; hock hobbles; tack collars; tack curb straps or tack hackamores; whips used for showmanship; war bridles or like devices; riding in a curb bit without a curb strap; wire or solid metal curb straps no matter how padded; wire cavesson; wire or cable tie-downs; bumper bits; metal bosals (no matter how padded); chambons; headstalls made of metal (no matter how wrapped or padded), twisted rawhide, or rope may not be used on a horse's head (3/8 inch rope may be used with a slip/gag bit or a bonnet); running martingales used with curb bits used without rein stops; draw reins attached between or around the front legs will not be allowed at IWHA events.

Jerk lines for roping.

Tack collars for roping.

Tie-downs may not have a built-in cavesson or noseband. Cavesson or noseband of any kind may not be used during competition.

Fenders or stirrups may not be connected by string or any other material.

**S12** The judge shall examine and check for lameness of all horses brought into any class. The judge has the authority to excuse any horse from the class, due to lameness, at any time while being judged. This is essential regardless of whether or not the competition indicates it is necessary.

Obvious lameness shall be cause for disqualification. Obvious lameness is:

Consistently observable at a trot under all circumstances;

Lameness is obvious at a walk;

Minimal weight-bearing in motion and/or at rest and inability to move.

**S13 GAITS** The following terminology shall apply:

Walk - A four-beat gait. True, flat-footed and ground-covering.

Jog-Trot - A two-beat gait. Free, square, slow and easy. Ground covering. When asked to extend the jog, it moves out with the same smooth way of going.

Lope - A true three-beat gait. Smooth, slow, relaxed, easy and straight on both leads. Horses moving to the left should lope on the left lead. Horses moving to the right should lope on the right lead.

**S13A** There will be an order of priority for evaluating western gaits. This hierarchy of consideration must be adhered to by judges and will be a great aid to exhibitors for how their horses should be presented. Following are the requirements in order of importance.

**Correctness**-Concerning correctness, which is the most important element of the hierarchy, judges must assess if the exhibitor has performed each gait correctly as defined during all or the majority of all of the class in order to have a correct or positive evaluation. For western gaits, this includes a four-beat walk, two beat jog and three-beat lope. The distinctness of the designated cadence for the gait being performed is essential.

**Quality**-Concerning quality, which is the second most important element in the hierarchy, and can only be considered positively if the gait performance has complied with the first element of correctness. When evaluating the pleasing characteristics of a gait, among many considerations, judges must consider overall gracefulness, relaxed expression, topline, softness of movement, consistency and length of stride of the designated gait.

**Degree of Difficulty**-Concerning degree of difficulty, this is the least important and last element of the hierarchy. This element must only be considered if the requirement for correctness has been met and combination of correctness and quality allow the performance to be considered for placement. Difficulty is greatly influenced by exhibiting a pleasure horse that is willingly guided with little or no apparent resistance at a cadence that allows for correctness and best quality of a gait for that individual. A performance of a walk that is ground covering and free flowing has a high degree of difficulty. A jog or lope that is performed with a slow rhythm without sacrificing correctness or quality has a high degree of difficulty. Slowness that sacrifices correctness or negatively impacts quality shall be considered incorrect and a poor performance at best.

**S13B** The following terminology is a description of western pleasure gaits:

**Poor Walk** - uneven pace and no cadence. Has no flow and may appear intimidated or appear to march.

**Average Walk** - has a four-beat gait, level top-line and is relaxed.

**Good Walk** - has a flowing four-beat gait, level top-line, relaxed and is bright and attentive.

**Extremely Poor Jog** - cannot perform a two-beat gait and has no flow or balance in the motion.

**Very Poor Jog** - hesitates in the motion. Does not keep an even and balanced motion or a level top-line. May appear to shuffle.

Poor Jog - average motion but has negative characteristics such as; walking with the hind legs, dragging the rear toes or taking an uneven length of stride with the front and rear legs.

Correct or Average Jog - has a two-beat gait, a level topline and a relaxed appearance.

Good Jog - has an average motion with positive characteristics such as balance and self-carriage while taking the same length of stride with the front and rear legs.

Very Good Jog - is comfortable to ride while having a consistent two-beat gait. The horse guides well, appears relaxed and has a level top-line.

Excellent Jog - effortless and very efficient motion. Swings the legs yet touches the ground softly. Confident, yet soft with its motion while being balanced and under control. Moves flat with the knee and hock and has some cushion in the pastern. Has a bright and alert expression and exhibits more lift and self-carriage than the “very good jog.”

Poor Extended Jog - never lengthens the stride and may appear rough to ride.

Average Extended Jog - moves up in its pace and appears smooth to ride.

Good Extended Jog - has an obvious lengthening of stride with a slight increase in pace

Extremely Poor Lope - does not have a three-beat gait. Has no flow, rhythm or balance. Uncomfortable to ride.

Very Poor Lope - appears to have a three-beat lope but has no lift or self-carriage. The horse shuffles, has no flow and bobs his head, giving the appearance of exerting a great deal of effort to perform the gait. Also may appear uncomfortable to ride.

Poor Lope - has an average motion but exhibits negative characteristics like head bobbing, not completing the stride with the front leg and leaving the outside hock well behind the horse’s buttocks.

Average Lope - has a true three-beat gait with a level topline and very little head and neck motion. He is relatively straight (not over-canted), guides well and has a relaxed appearance.

Good Lope - has an average motion but exhibits positive characteristics in his performance like self-carriage, a steady topline, relaxed appearance and is responsive to the rider’s aids.

Very Good Lope - has more lift and flow than the average horse. He has a strong but smooth drive from behind. He may bend his knee slightly yet still has a level top-line while exhibiting self-carriage with a relaxed appearance. Appears comfortable to ride.

Excellent Lope - has a round back with an effortless strong, deep stride with the rear legs and a flat swing with the front legs. He keeps a level top-line, a relaxed yet alert and confident appearance and is correct but soft. A special horse with a great degree of lift and self-carriage.

Poor Back-Up - is resistant and heavy in front. May gap the mouth and throw his head or back crooked.

Average Back-Up - backs straight and quietly with light contact and without hesitation.

Good Back-Up - displays balanced and smooth flowing movements. Backs straight with self-carriage without gapping the mouth with light contact and without hesitation.

**S13C** The following terminology is a description of ranch class gaits:

In all gaits, movement of the ranch horse should simulate a horse needing to cover long distances, softly and quietly, like that of a working ranch horse. The following terminology shall apply:

Walk - the walk is a natural, flat footed, four-beat gait. The gait is rhythmic and ground-covering. As in all gaits, the horse should display a level, or slightly above level topline with a bright, attentive expression.

Extended Walk – the extended walk is an obvious lengthening of stride that will naturally increase the pace. The horse should move in a natural manner (not a running walk) as if it were moving across an open pasture.

Trot- the trot is a natural two-beat gait demonstrating more forward motion than the western jog.

Extended Trot- the extended trot is an obvious lengthening of the stride with a definite increase in pace. The horse should be moving in a manner as if it were covering a large area on a ranch with an above level topline.

Lope- the lope is a three-beat gait. The lope should be relaxed and smooth with a natural, forward moving stride.

Extended Lope- the extended lope is not a run or a race but should be an obvious lengthening of the stride, demonstrating a forward, working speed. The horse should display an above level topline with a bright, attentive expression.

**S14 ATTIRE**

In performance halter, speed events and other western classes, appropriate western attire is required which includes pants (slacks, trousers, jeans, etc.) shirt with long sleeves and collar (band, standup, tuxedo, etc.), western hat and cowboy (western) boots. Chaps and spurs are

optional. Chinks are acceptable if they are equipped with fringe and/or western conchos. It is optional, and will not be penalized, if an exhibitor wears a hard hat with harness in all classes. The hat must be on the rider's head when the exhibitor enters the arena. Exhibitors under 18 years of age or under may not be tied, buckled or fastened by any other means during any competition.

## **S15 PERFORMANCE HALTER**

To show in performance halter, the horse must be entered and ridden in at least two performance classes. It is acceptable to show mares, stallions and geldings, as well as purebreds and partbreds together in one class. Separation of the classes into gender will depend on the number of entries and be at the discretion of the show management.

The Andalusian and Lusitano horse is known for agile movements, elevated, extended, harmonious and cadenced. The horse has great facility to adopt various aptitudes and to conquer difficulties, as if with special predisposition for collection and the turns over the haunches. The horses have an easy response to the command and the mouth is additionally soft, for a result that is obedient and of extraordinary comfort. The horses are temperate and hardy, serviceable and energetic, noble and docile. They learn rapidly and participate intimately with the rider. Their principal service is as a mount, with great ability for "alta escuela" (dressage and airs), bullfighting, light teams or carriages and with special conditioning for handling cattle running in range conditions.

The head should be in proportion to the overall size and weight of the horse. It should be rectangular in shape, and of medium length, with a long jaw that is not overly pronounced. Profile: straight or convex, nostrils are elongated and arched. Eyes: large, lively, showing a kind and alert expression, their shape is triangular with a permanently raised eyebrow. The ears are attached slightly lower on the side of the head compared to other breeds, but must stand up straight without a curl to the inside or falling to the outside. The size must be in proportion to the head. Mares sometime have longer, narrower ears. The neck should be of medium length, solidly built and lightly arched with neither a heavy crest nor a thick throat. Withers should be prominent, moderately wide, and muscular. The shoulder should be long, broad, well sloping and powerfully muscled. Ribs are well sprung and oval. Forearms should be large, well-muscled and in correct proportion to the width of the chest. Cannon bones are substantial, slightly longer, lean and in proportion to the horse's height. The back should be of medium length, straight and horizontal. The loin shall be broad, short and strong. Croup should be gently sloping and nicely rounded with a low set, thick tail fitted following the curvature of the croup. Viewed from the rear the tail should be carried straight, hips should be strong and rounded, and there should be a well-muscled thigh and gaskin of medium length. Hind leg cannon bones should be of proportioned length and clean tendons. The hock should be straight and well defined. The pasterns should be of medium slope and length and be well flexioned. Hooves are round and of proportionate size.

The height at the withers varies from 15 hands to 16.1 hands with an occasional individual under or over. Mares should be feminine and males should be masculine. Andalusians/Lusitano shall be medium in length, and if other than medium, excessive length of body is less desirable than

short length. Movement: elevated, extended, harmonious and cadenced with roundness yet always moving forward.

To be penalized are less than desirable Andalusian/Lusitano traits: Concave frontal nasal profiles and the ultra-convex nasal profiles. Excessively large heads, forehead too wide and flat. Eyes bulging or round, orbital arches protruding. Nose square and wide, nostrils round. Ears too big, fallen, too closely set and with abnormal movement. Neck too short, low set neck or thick throatlatch. Low withers, swayback, or back tent- shaped. Poorly muscled, thin or weak rib structures, cylindrical thorax, chest and barrel not deep enough. Tail set too high, or too loosely set. Cow hocks or uneven hocks. Pasterns too long or excessively short and vertical. Movements displaying poor elevation, irregular tempo or excessive winging.

Emphasis shall be placed on type, conformation, quality, way of going, substance and manners. Half Andalusians/Lusitano will be judged on conformation, quality, way of going, substance and Andalusian/Lusitano type, in that order. The Half-Andalusians/Lusitano may show characteristics of any other breed. The foregoing first three qualities shall take precedence in adjudication of in-hand classes over breed type.

An exhibitor is any person who holds, walks or trots a horse in the competition arena. No Exhibitor may hold more than one horse at a time in the arena.

#### **S15A PROCEDURE FOR JUDGING HALTER.**

Horses will walk to the judge one at a time. As the horse approaches, the judge will step to the right (left of the horse) to enable the horse to trot straight to a cone placed 50 feet (15 meters) away. At the cone, the horse will continue trotting, turn to the left making a true “L” and trot toward the next cone placed before the left wall or fence of the arena. After trotting, horses will be lined up head to tail for individual inspection by the judge. The judge shall inspect each horse from both sides, front and rear.

At single judged shows, the judge should line the horses to be placed in a head to tail order according to preference.

A well-mannered horse is a horse that (1) is under control by the exhibitor while tracking and standing for inspection and (2) is reasonably still and flat-footed while standing for inspection.

For purposes of this rule, the term “disruptive behavior” includes, but is not limited to rearing, striking, biting, or backing or falling into others.

Judges should disqualify and excuse from the ring prior to final placing horse that:

- exhibits disruptive behavior such that it or other horses are unable to be inspected by the judge;

- exhibits disruptive behavior such that the safety of it, the handler, an exhibitor, a judge or another horse is endangered;

is not under the control of the exhibitor;  
becomes detached from the exhibitor;  
has fallen and is on its side with all four feet extended in the same direction;  
is observed with blood on its body, including, but not limited to, the nose, chin, mouth, tongue, or gums, regardless of cause;  
fails to complete the prescribed pattern correctly in three (3) attempts.

Rather than disqualify, a judge may choose to fault a horse that is exhibiting disruptive behavior so long as such disruptive behavior does not qualify as being any of the behaviors described immediately above.

If a horse exhibits disruptive behavior and causes other exhibitor(s) to lose their horse(s), only the initiating horse will be disqualified and excused. The decision of the judge(s) will be final.

All stallions shall be examined to confirm that they have two visible testicles. All mares and stallions shall be examined for parrot mouth. If examination reveals that a horse has parrot mouth or is cryptorchid, such horse should be excused from the ring prior to final placing by the judge regardless of whether the parrot mouth or cryptorchid condition is marked on the horse's registration certificate.

## **S16 WESTERN PLEASURE**

Horses are to be reversed to the inside (away from the rail) and will not be asked to reverse at the lope.

Light hand contact with the horse's mouth must be maintained at all gaits without undue restraint.

Only one hand may be used around the reins, and hands must not be changed. Two hands may be used when a Junior Horse is being shown in a snaffle bit or hackamore.

The horse must be ridden with the horse's eyes generally at or above the withers in all gaits.

Excessive speed at any gait must be penalized.

Horses are to be shown at a walk, jog-trot and lope on a reasonably loose rein both ways of the ring. See 13B above for qualifying gaits.

A walk/trot class for youth exhibitors only may be held at the discretion of the show manager.

## **S17 RANCH RIDING**

The purpose of the ranch riding class is to measure the ability of the horse to be a pleasure to ride while being used as a means of conveyance from performing one ranch task to another. The horse should reflect the versatility, attitude and movement of a working ranch horse riding outside the confines of an arena. The horse should be well-trained, relaxed, quiet, soft and cadenced at all gaits. The ideal ranch horse will travel with forward movement and demonstrate an obvious lengthening of stride at extended gaits. The horse can be ridden with light contact or on a relatively loose rein without requiring undue restraint, but not shown on a full drape of reins. The overall manners and responsiveness of the ranch riding horse to make timely transitions in a smooth and correct manner, as well as the quality of the movement are of primary considerations. The ideal ranch riding horse should have a natural ranch horse appearance from head to tail in each maneuver.

No horse may cross enter a western pleasure or walk-trot western pleasure and ranch riding class

Each horse will work individually. Horses will be scored on the basis of 0 to 100, with 70 denoting an average performance. Each maneuver will receive a score that should be added or subtracted from 70 and is subject to a penalty that should be subtracted. Each maneuver will be scored on the following basis, ranging from plus 1 1/2 to minus 1 1/2.: -1 1/2 extremely poor, -1 very poor, -1/2 poor, 0 correct, +1/2 good, + 1 very good, + 1 1/2 excellent. Maneuver scores are to be determined and assessed independently of penalty points. Natural ranch horse appearance will also be evaluated ranging from plus 1 1/2 to minus 1 1/2.

One of the 15 approved patterns from the current year American Quarter Horse Association (AQHA) Rule Book will be used.

The overall cadence and performance of the gaits should be as those described in S13C above, ranch class gaits, with an emphasis on forward movement, free-flowing, and ground covering for all gaits. Transitions should be performed where designated, with smoothness and responsiveness.

No time limit.

The use of natural logs is required.

Sitting the regular trot and lope is recommended; though standing in the stirrups at the extended trot and extended lope, or posting the extended trot is acceptable.

Touching or holding the saddle horn is acceptable.

It is suggested competitors use a breast collar and a rear cinch.

When exhibiting in a snaffle bit or hackamore, an exhibitor may switch between two hands and one hand on the reins at any time.

**S17A Penalties.** Maneuver evaluations and penalty applications are to be determined independently. The following penalties will be applied to each occurrence and be deducted from the final score:

<b>One (1) point</b>	Too slow (per gait) Over-bridled (per maneuver) Out of frame (per maneuver) Break of gait at walk or trot for 2 strides or less Wrong lead or out of lead for 2 strides or less
<b>Three (3) point</b>	Break of gait at walk or trot for more than 2 strides Break of gait at lope, except when correcting an incorrect lead Wrong lead or out of lead for more than two strides Draped reins (per maneuver) Out of lead or cross-cantering more than two strides when changing leads Trotting more than 3 strides when making a simple lead change Trotting for more than 3 strides in lope departures or exiting a rollback into a lope from a stop or walk Severe disturbance of any obstacle
<b>Five (5) point</b>	Blatant disobedience (including, kicking, biting, bucking, rearing and striking) for each refusal
<b>Off Pattern (OP)</b>	Placed below horses performing all maneuvers Eliminates or adds maneuver Incomplete maneuver Repeated blatant disobedience Use of two hands (except junior horses shown in a snaffle bit/hackamore), more than one finger between split reins or any fingers between romal reins (except in the two rein)
<b>Zero (0) score</b>	Abuse Illegal equipment including hoof black, braided or banded manes, or tail extensions Lameness Leaving working area before pattern is complete Disrespect or misconduct Improper western attire

### Fall of horse/rider

No specific penalties will be incurred for nicks/hits on logs but deduction may be made in maneuver score.

No specific penalties will be incurred for over/under spins but deduction may be made in maneuver score.

## RANCH RIDING - PATTERN I

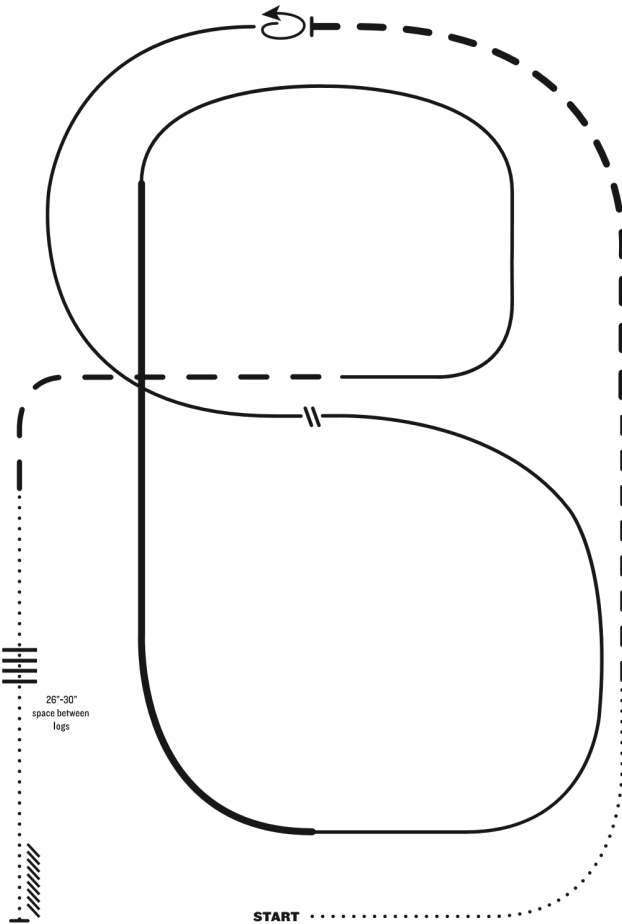

**LEGEND**

.....	Walk
.....	Extended Walk
- - - -	Trot
- - - -	Extended Trot
————	Lope
————	Extended Lope
//////	Back
//	Lead Change

*Note: The drawn description of this pattern is only intended for the general depiction of the pattern. Exhibitors should utilize the arena space to best exhibit their horses.*

1. Walk
2. **Trot**
3. **Extend the trot, at the top of the arena, stop**
4. **360° turn left**
5. **Left lead 1/2 circle, lope to the center**
6. **Change leads (simple or flying)**
7. **Right lead 1/2 circle**
8. **Extended lope up the long side of the arena (right lead)**
9. **Collect back to a lope around the top of the arena and back to center**
10. **Break down to an extended trot**
11. **Walk over logs**
12. **Stop and back**

**RANCH RIDING - PATTERN 2**

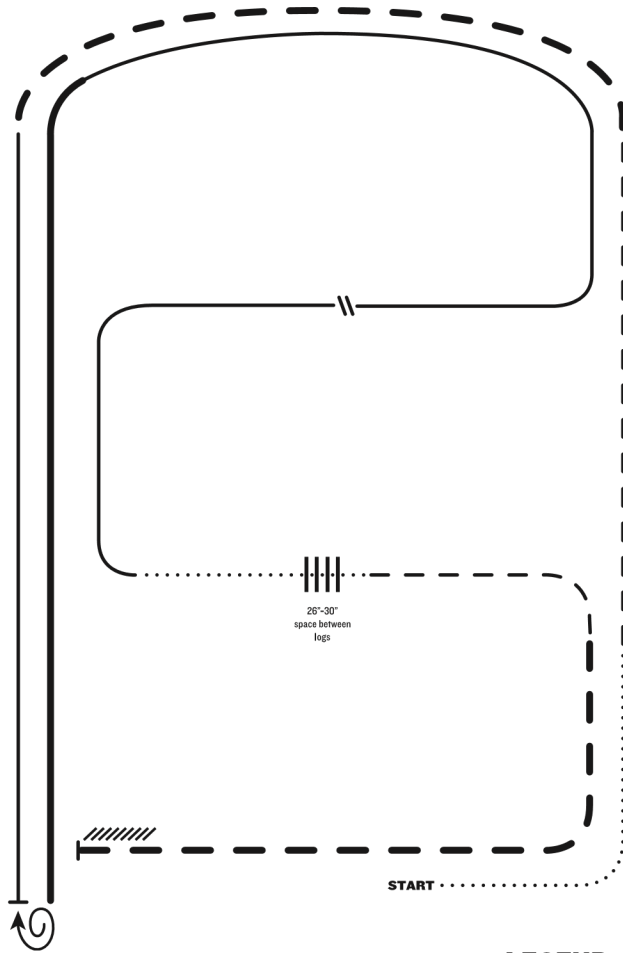

LEGEND	
.....	Walk
.....	Extended Walk
- - - -	Trot
- - - -	Extended Trot
————	Lope
————	Extended Lope
////	Back
//	Lead Change

1. Walk
2. Trot
3. Extended trot
4. Lope left lead
5. Stop, 1 1/2 turn right.
6. Extended lope
7. Collect lope right lead
8. Change leads (simple or flying), continue lope left lead
9. Walk
10. Walk over logs
11. Trot
12. Extended trot
13. Stop and back

**RANCH RIDING - PATTERN 3**

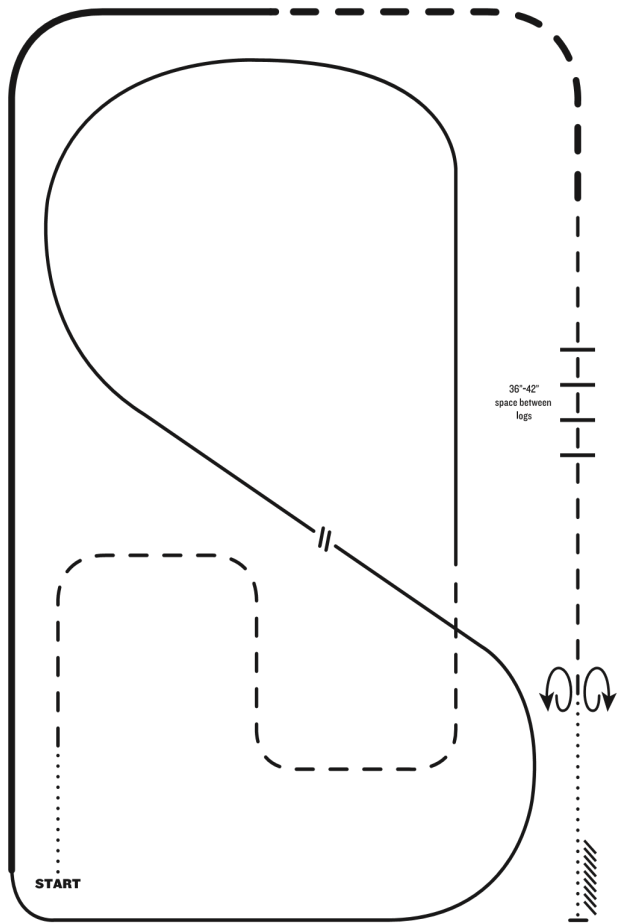

**LEGEND**

.....	Walk
.....	Extended Walk
----	Trot
----	Extended Trot
—	Lope
—	Extended Lope
////	Back
//	Lead Change

*Note: The drawn description of this pattern is only intended for the general depiction of the pattern. Exhibitors should utilize the arena space to best exhibit their horses.*

1. Walk
2. Trot serpentine
3. Lope left lead around the end of the arena and then diagonally across the arena
4. Change leads (simple or flying)
5. Lope right lead around end of the arena
6. Extend lope on the straight away and around corner to the center of the arena
7. Extend trot around corner of the arena
8. Collect to a trot
9. Trot over logs
10. Stop, 360° turn each direction (either direction 1st) (L-R or R-L)
11. Walk, stop and back



**RANCH RIDING - PATTERN 5**

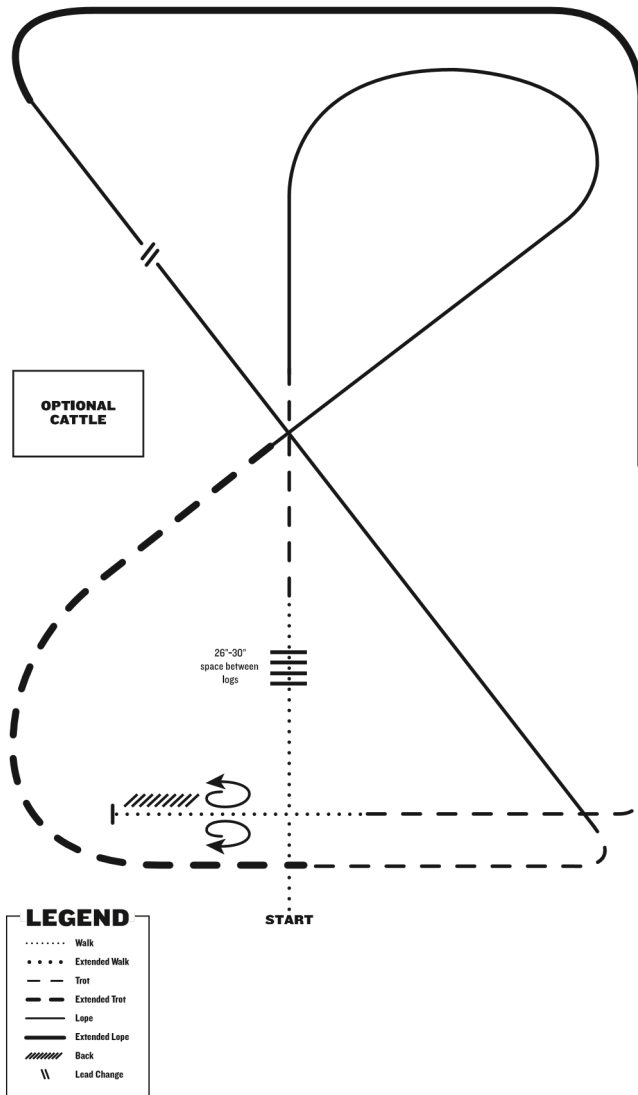

1. Walk
2. Walk over logs
3. Trot
4. Lope right lead
5. Extended trot
6. Trot
7. Lope left lead
8. Change leads (simple or flying)
9. Extended lope right lead
10. Collect lope
11. Trot
12. Walk
13. Stop and back
14. 360° turn each direction (either direction 1st) (L-R or R-L)

1. Walk
2. Walk over logs
3. Lope right lead
4. Extended lope right lead
5. Trot
6. Stop, 1 1/2 turn right
  
7. Walk
8. Trot
9. Extended trot
10. Lope left lead
11. Stop and back
12. Side pass right

RANCH RIDING – PATTERN 6

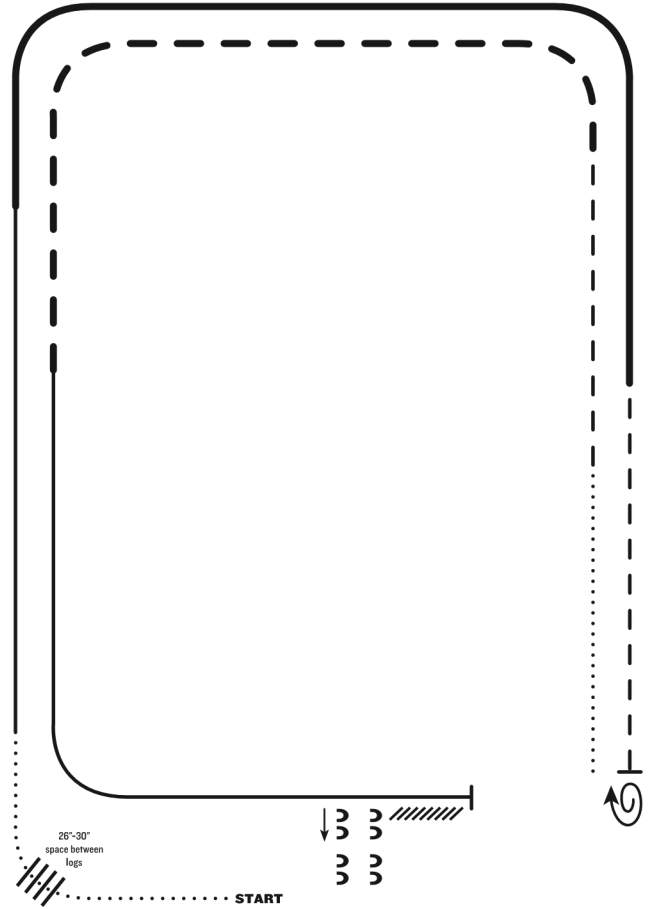

1. Walk
2. Trot
3. Extended trot
4. Stop and back
5. Side pass right over log
6. 1/4 turn right, walk over logs
7. Walk
8. Lope left lead
9. Extended lope left lead
10. Collect lope, change leads (simple or flying)
11. Lope right lead
12. Trot
13. Stop, one 360° turn either direction

**RANCH RIDING - PATTERN 7**

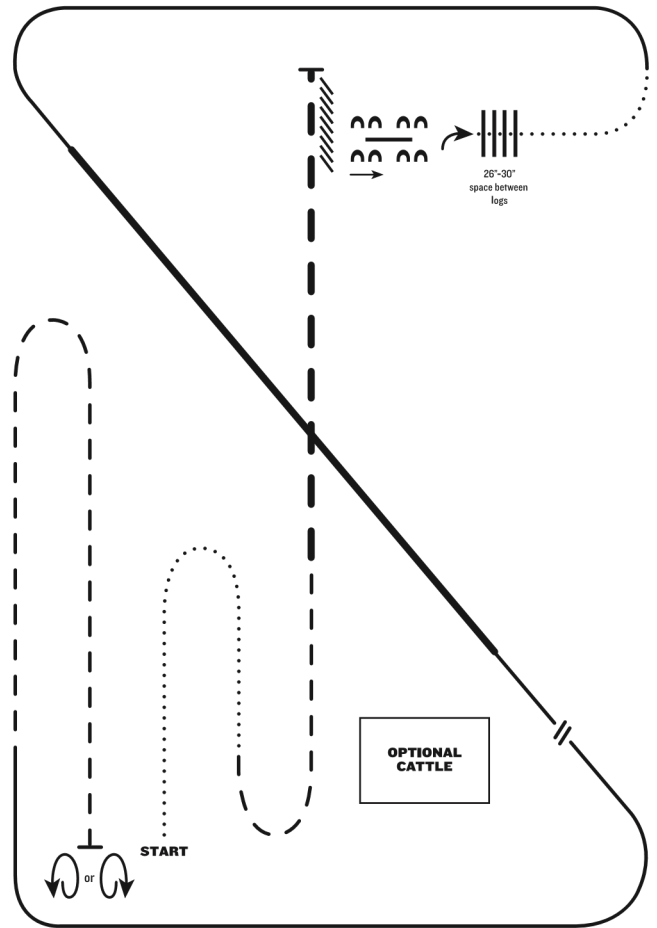

LEGEND	
.....	Walk
.....	Extended Walk
---	Trot
---	Extended Trot
---	Lope
---	Extended Lope
////	Back
//	Lead Change

LEGEND	
—	Walk
—	Extended Walk
- - -	Trot
- - -	Extended Trot
—	Lope
—	Extended Lope
////	Back
∩	Lead Change

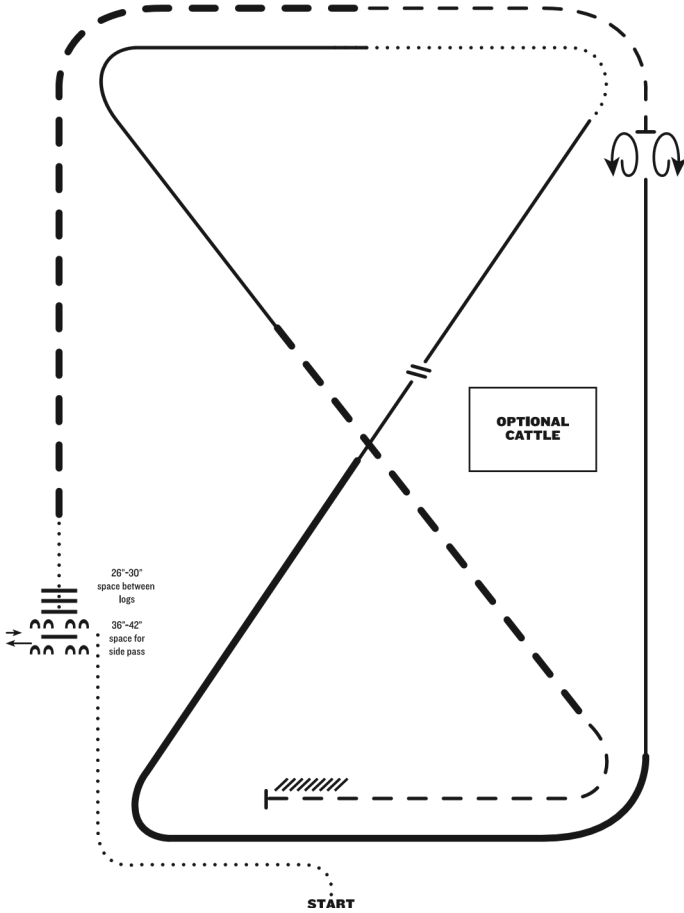

## RANCH RIDING – PATTERN 8

1. Walk
2. Side pass left across first log, side pass ½ way to right
3. Walk over logs
4. Extended trot
5. Trot
6. Stop, 360 turn each direction (either direction first)
7. Lope right lead
8. Extended lope right lead
9. Collect lope, change leads (simple or flying), continue lope left lead
10. Walk
11. Lope, left lead
12. Extended trot
13. Trot
14. Stop and back

**RANCH RIDING - PATTERN 9**

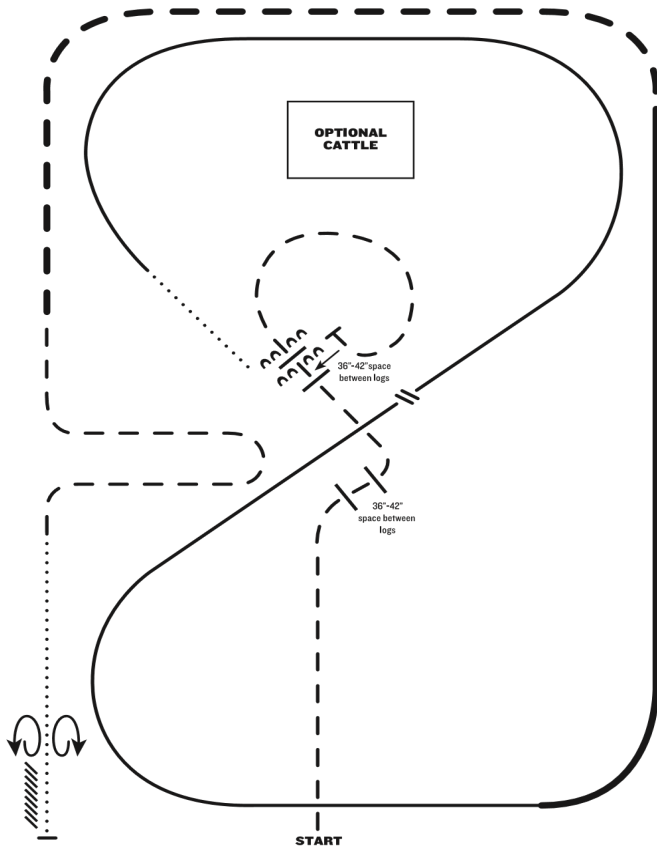

1. Trot
2. Trot over two sets of logs
3. Trot circle, stop and side pass left over log
4. Walk
5. Lope right lead
6. Change leads (simple or flying)
7. Lope, left lead
8. Extended lope, left lead
9. Extended trot
10. Trot
11. Walk
12. Stop and back
13. 360 in each direction (either first)

**LEGEND**

- ..... Walk
- ..... Extended Walk
- Trot
- Extended Trot
- Lope
- Extended Lope
- //// Back
- \\ Lead Change

1. Trot

## RANCH RIDING – PATTERN 10

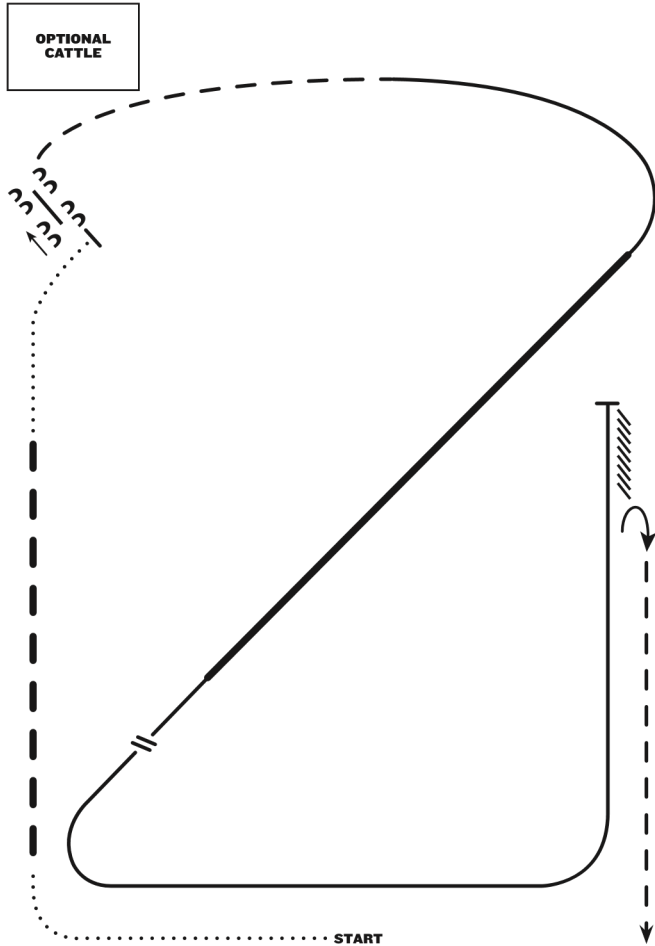

1. Walk
2. Extended trot
3. Walk
4. Stop, side pass over log
5. Trot
6. Lope right lead
7. Extended lope right lead
8. Collect lope and change leads (simple or flying)
9. Lope left lead
10. Stop and back
11. ½ turn right
12. Trot

**LEGEND**

- ..... Walk
- ..... Extended Walk
- - - Trot
- - - Extended Trot
- Lope
- Extended Lope
- //// Back
- ∩ Lead Change

## RANCH RIDING – PATTERN 11

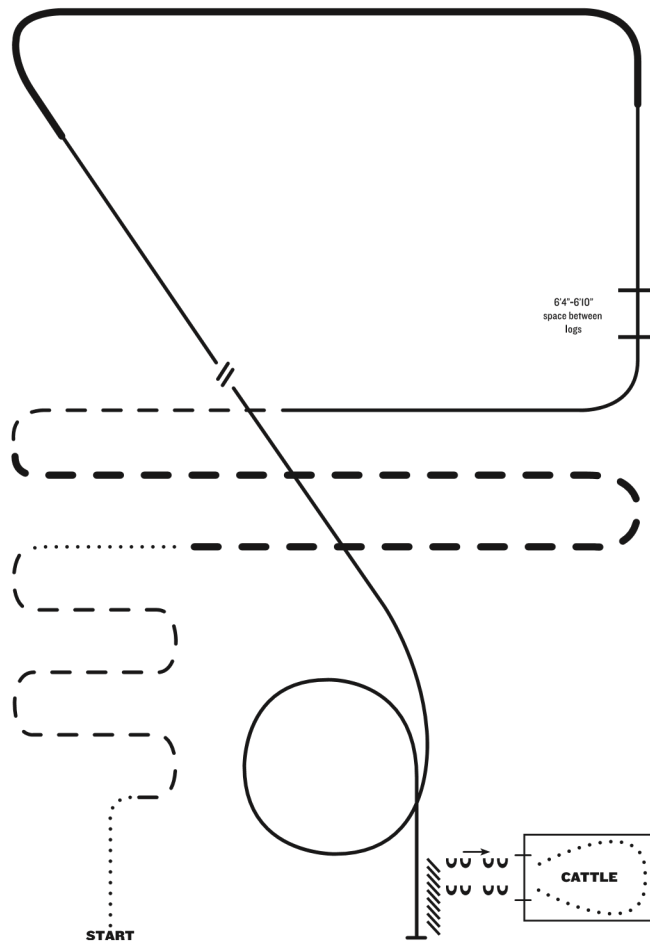

1. Walk
2. Trot serpentine
3. Walk
4. Extended trot
5. Trot
6. Lope, left lead
7. Lope over logs
8. Extended lope left lead
9. Collect lope, change leads (simple or flying)
10. Lope right lead
11. Lope circle
12. Stop and back
13. Side pass to gate, left hand push into pen
14. Walk through cattle, right hand push out

1. Walk
2. Trot serpentine

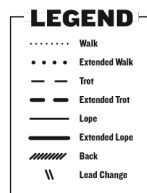

# RANCH RIDING PATTERN 12

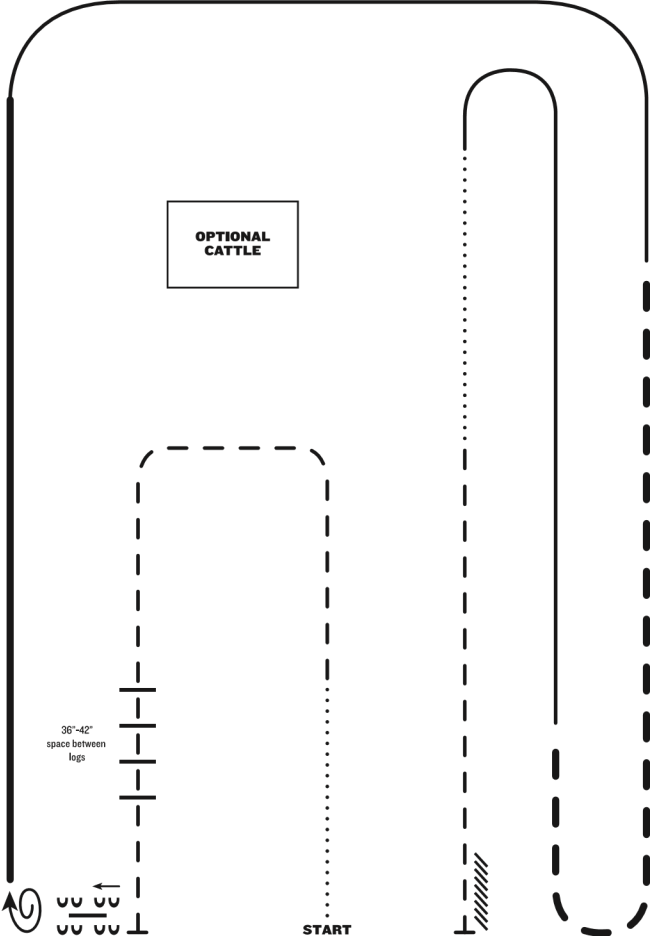

1. Walk
2. Trot
3. Trot over logs, stop
4. Side pass right over log
5. 1 1/2 turn right
6. Extended lope right lead
7. Lope right lead
8. Extended trot
9. Lope left lead
10. Walk
11. Trot
12. Stop and back

*Note: The drawn description of this pattern is only intended for the general depiction of the pattern. Exhibitors should utilize the arena space to best exhibit their horses.*

LEGEND	
.....	Walk
.....	Extended Walk
- - - -	Trot
- - - -	Extended Trot
— — — —	Lope
— — — —	Extended Lope
//////	Back
\\	Lead Change

## RANCH RIDING – PATTERN 13

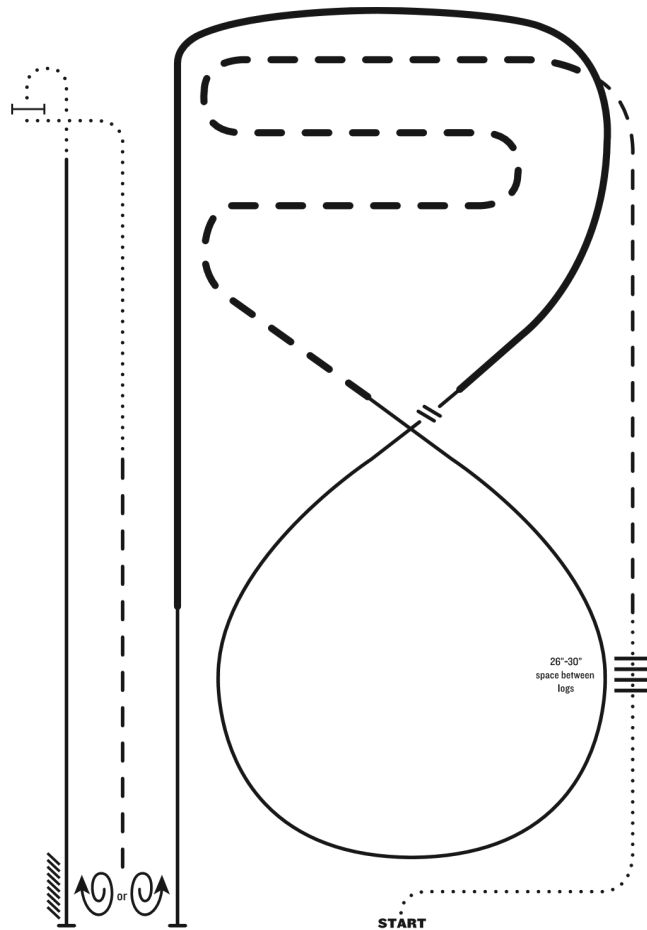

1. **Walk**
2. **Walk over logs**
3. **Trot**
4. **Extended trot serpentine**
5. **Lope right lead**
6. **Change leads (simple or flying)**
7. **Extended lope left lead, collect lope**
8. **Stop, 1 1/2 turn either direction**
9. **Trot**
10. **Walk to gate**
11. **Right hand push gate**
12. **Walk, lope left lead**
13. **Stop and back**

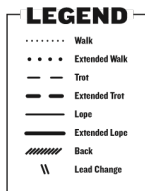

1. Walk
2. Walk over logs
3. Trot
4. Extended trot serpentine

## RANCH RIDING – PATTERN 14

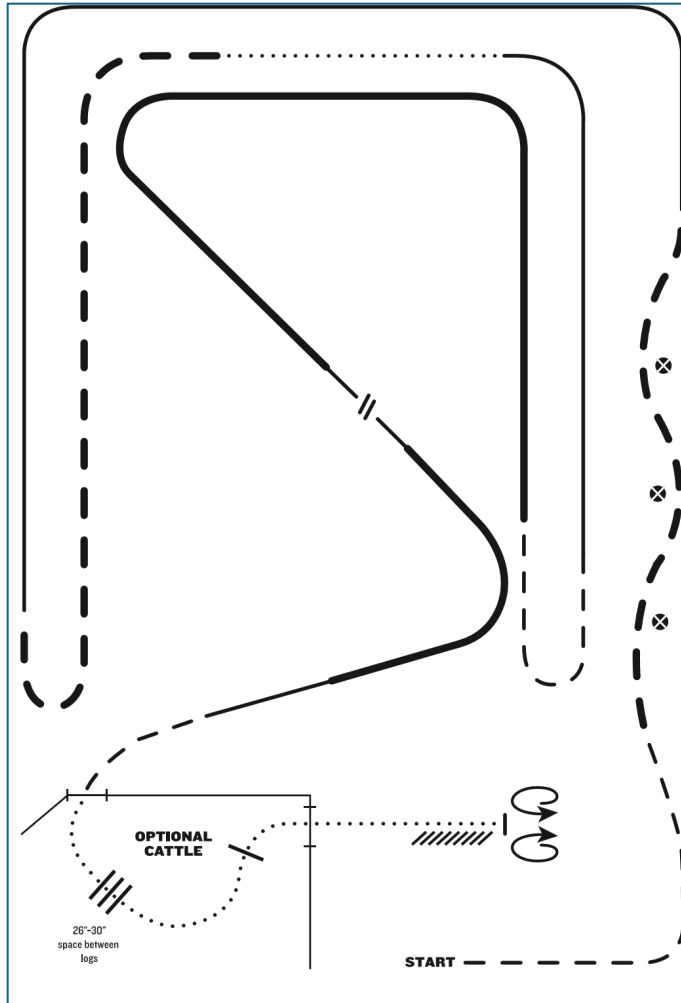

1. Trot
2. Extended trot
3. Lope left lead
4. Extended trot
5. Walk
6. Lope right lead
7. Trot
8. Extended lope, left lead
9. Collect lope, change leads (simple or flying), extended lope right lead, collect lope
10. Trot
11. Left hand push gate into pen
12. Walk over logs
13. Right hand push gate out of pen
14. Walk
15. Stop, 360 degree turn each direction (either first)
16. Back

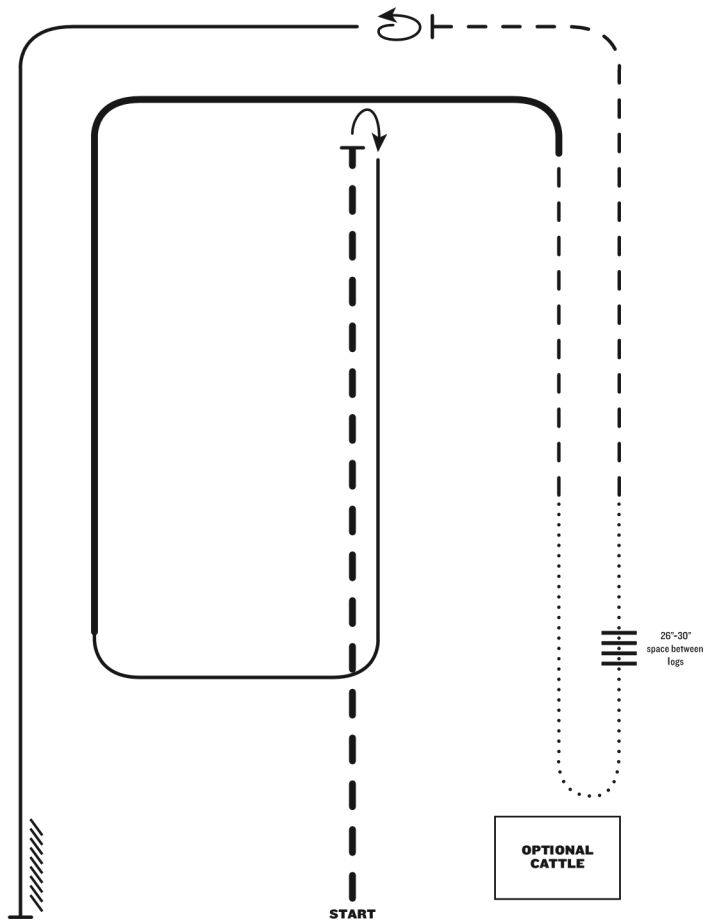

## RANCH RIDING – PATTERN 15

1. **Extended trot**
2. **Stop, rollback right**
3. **Lope right lead**
4. **Extended lope right lead**
5. **Trot**
6. **Walk**
7. **Walk over logs**
8. **Walk**
9. **Trot**
10. **Stop, 360° turn left**
11. **Lope left lead**
12. **Stop and back**

## **S17 RANCH PLEASURE**

Ranch pleasure is a pattern class that is ridden on the rail. The patterns may start either direction, to the right or left. This class serves to measure the ability of the horse to be functional and a pleasure to ride while being used as a means of conveyance from performing one stock/ranch task to another. The horse should reflect the versatility, attitude, and movement of a working stock/ranch horse riding outside the confines of an arena.

The horse should be well-broke/trained, relaxed, quiet, soft and cadenced at all gaits. While soft in the bridle the horse should yield to contact. The horse can be ridden with light contact or on a relatively loose rein without requiring undue restraint, but not shown with excessively draped reins.

The overall manners and responsiveness of the ranch pleasure/ranch riding horse is to make timely transitions in a smooth and correct manner, as well as the quality of the movement are of primary considerations.

The ideal ranch horse will travel with forward movement and demonstrate an obvious lengthening of stride at extended gaits.

The class may be conducted inside or outside of an arena. An arena provides good footing for stops in the pattern.

Show management set markers to designate gait changes/transitions. When setting up markers, the following distances are recommended. These distances will make for a more fluid class to be exhibited and facilitate ease of judging. In smaller arenas, it may be necessary to adjust the course to get distances similar to those recommended.

<b>Extended Walk</b>	<b>(75 feet)</b>	<b>Extended Trot</b>	<b>(240 feet)</b>
<b>Ordinary Walk.</b>	<b>(30 feet)</b>	<b>Lope</b>	<b>(150 feet)</b>
<b>Trot</b>	<b>(90-120 feet)</b>	<b>Extended Lope</b>	<b>(200 feet)</b>

It is recommended that the judge walk the pattern to approve the markers and distances for each gait.

Judges should stand in the center of the arena while judging the ranch horse pleasurer class from the center of the arena, except in extreme circumstances.

Pleasure riding pattern 1 or 2 from the current American Stock Horse Association Rulebook will be used.

### **S17A Required elements for Ranch Horse Pleasure Patterns:**

- A.** Horses will be shown individually at three (3) gaits; walk, trot, and lope in each direction of the arena.
- B.** Horses will also be asked to reverse, stop, and back.
- C.** The extended trot and lope should be demonstrated at least one direction of the arena.

## **S17B Scoring**

Part of the evaluation of this class is on smoothness of transitions. There is no advantage to making these transitions with cues that are imperceptible to a judge. Judges expect to see horses that have been trained to respond to cues. To see these cues applied discretely and the horse responding correctly could be a credit earning situation.

All transitions should be smooth without unnecessary resistance from the horse. Please note that the rules allow for a horse to be taken back (collected) a bit from the extended trot as the horse moves into the lope. The transition from the extended lope down to the trot is very difficult to achieve, however, a good stock/ranch horse will have to make this transition several times during a day's work. This transition is down to the normal or seated trot, not the extended trot. Therefore, an extra cue to achieve this gait is expected. Horses that complete this total transition within three (3) strides calmly and obediently should be rewarded. Horses that attempt to stop or bring the hocks together to go into a stopping position should receive a lower score according to the magnitude of the error.

Each gait, including transitions toward that gait, will be scored.

All runs begin upon entering the arena and any infractions are subject to penalty at that time.

The rider has the choice in the extended trot to post, sit, or stand in the stirrups. Holding the saddle horn is permissible at the extended trot only. Preference should not be given by the judge for any method of showing, as emphasis should be on the performance of the horse and how effective the horse is at actually extending the trot and the mannerisms and responsiveness to the rider.

### **Credited Earning:**

- + High quality mover.
- + Functionally correct in gaits and transitions.
- + Well-mannered and responsive.
- + To see cues applied discretely and the horse responding correctly.

### **Minor Deductions (Less than 2 Points):**

- Artificial appearance and/or unnecessary delay.
- Break of gait at walk or trot.
- Too slow.
- Over-bridled and/ or out of frame (per maneuver).

### **Major Deductions (More than 2 Points):**

- Wrong lead or out of lead.
- Lack of control.
- Blatant disobedience (kicking out, bucking, rearing or striking).

- Very poor quality of gait. Failure to ever demonstrate correct lead or gait, if designated.
- Break of gait at lope.
- Excessive draped reins.
- Trotting for more than three (3) strides in lope departures.

## 2. Scoring System

For each class, horses will be scored from 0 to 100, with 70 denoting an average performance. Maneuver scores should be added and subtracted from the 70 and are to be determined and assessed independently of any penalty points which may accrue. Each maneuver will receive a score ranging from: Specific deductions are listed with each class)

- + 1.5 **Excellent**
- + 1 **Very Good**
- + .5 **Good**
- 0 **Correct**
- .5 **Poor**
- 1.0 **Very Poor**
- 1.5 **Extremely Poor**

**Off-Pattern (OP):** In the case of a horse/rider team being off-pattern (OP), including repeated blatant disobedience, breaking pattern, incomplete maneuver, eliminating or adding maneuvers, use of two (2) hands, more than one finger between split reins or any fingers between romal reins (except in the two-rein) the horse/rider team cannot place above other horse/rider teams who have completed the pattern correctly.

**Disqualification (DQ):** Lameness, abuse, leaving the arena before pattern is complete, illegal equipment or attire, fall of horse/rider, out of control, dangerous, excessive schooling, and/or abuse, disrespect, or misconduct.



# Stock Horse PLEASURE #1

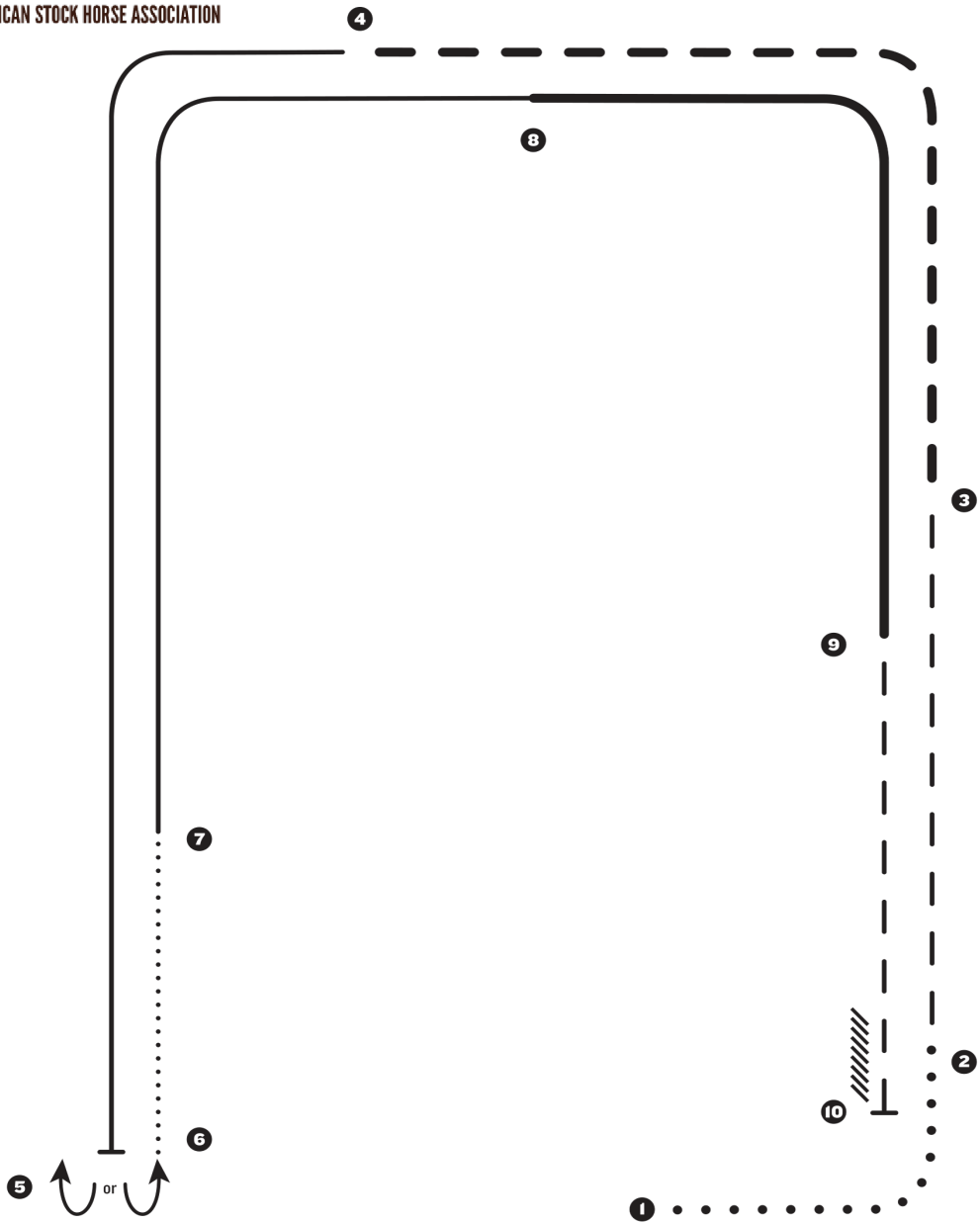

- 1. Extended walk
- 2. Trot
- 3. Extended trot
- 4. Lope

- 5. Stop and reverse
- 6. Walk
- 7. Lope
- 8. Extended lope

- 9. Trot
- 10. Stop and back



## Stock Horse PLEASURE #2

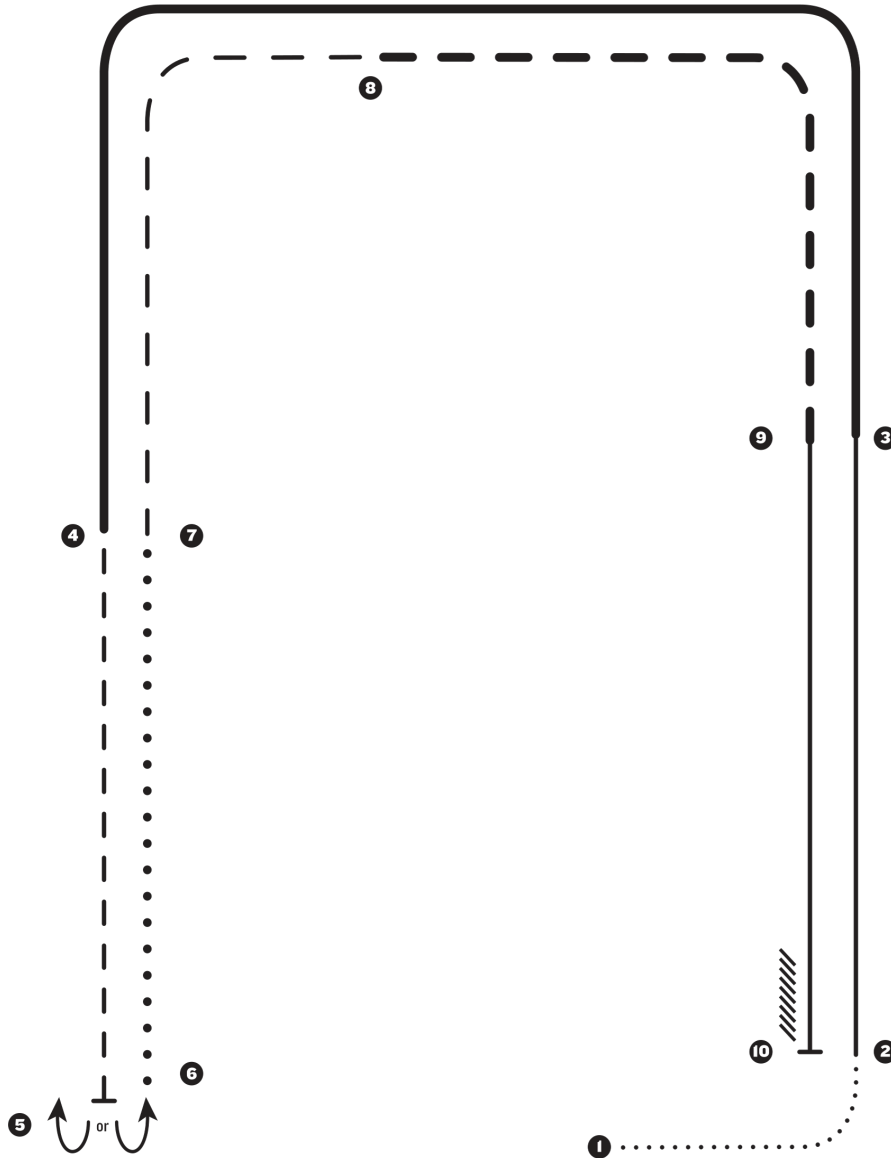

1. Walk
2. Lope
3. Extended lope
4. Trot
5. Stop and reverse
6. Extended walk

7. Trot
8. Extended trot
9. Lope
10. Stop and back

## **S18 RANCH TRAIL**

This class should test the horse's ability to cope with situations encountered while being ridden through a pattern of obstacles generally found during the course of everyday ranch work. The horse/rider team is judged on the correctness, efficiency, and pattern accuracy with which the obstacles are negotiated, and the attitude and mannerisms exhibited by the horse. Judging emphasis is on identifying the well broke, responsive, and well-mannered horse which can correctly navigate and negotiate the course. The ideal ranch trail horse should have a natural ranch horse appearance from head to tail in each maneuver.

**S18A**The ranch trail course will include no less than six and no more than nine obstacles. It is mandatory that the horse be asked to walk, trot and lope during the course. Walk can be part of obstacle score or be scored with the approaching obstacle. Trot must be at least 35 feet and score with approaching obstacle. Lope must be lead-specific, at least 50 feet and score with approaching obstacle. Care must be exercised to avoid setting up any obstacles that may be hazardous to the horse or rider.

When setting courses, management will be mindful that the idea is not to trap a horse/rider team or eliminate it by making an obstacle too difficult. All courses and obstacles are to be constructed with safety in mind so as to reduce the risk for accidents. Show committee shall have the option of setting up the trail course to best fit the arena conditions. An outdoor course is recommended if appropriate terrain is available. Each single-performance event can be time consuming, especially with large classes, so it is imperative that time restrictions are placed on this class. The show committee, either through a pilot run or estimation, shall select a course that has a continuous and positive flow that can be negotiated in four minutes or less.

Judges must walk the course and have the right and duty to alter the course if it is not in keeping with the intent of the class. Judges may remove or change any obstacles they deem unsafe, nonnegotiable or unnecessarily difficult. Any time a trail obstacle becomes unsafe during a class, it shall be repaired or removed from the course. If the course cannot be repaired and some horses have completed the course, the score for that obstacle shall be deducted from all previous draws in that class.

The course must be designed using the mandatory obstacles and maneuvers plus optional obstacles. Combining two or more of the obstacles is acceptable.

At show management's discretion, the competition trail course may be made available to exhibitors or posted prior to the day of competition. It must be posted at least one hour prior to competition. Printed handouts for exhibitors are helpful and encouraged.

**S18B PROHIBITED OBSTACLES:** Tarps, water obstacles with slick bottoms, PVC pipe used as a jump or walk over, tires, rocking or moving bridges, painted logs or poles, logs elevated in a manner that permits such to roll in a dangerous manner, any type of pinwheel regardless of spacing or gait.

**S18C MANDATORY OBSTACLES AND MANUEVERS**

1. Ride over obstacles on the ground (natural logs are required). Walk, trot or lope may be used but only one gait is required. - Walk-overs: Walk over no more than four logs no more than 10 inches high. The spacing between successive logs should be 26 – 30 inches. The formation may be straight, curved, zigzagged or raised. - Trot-overs: Trot over no more than four logs no more than 10 inches high. The spacing between successive logs should be 36-42 inches. The formation can be straight, curved, zigzagged or raised. - Lope-overs: Lope over no more than three logs no more than 10 inches high. No more than two logs may be used in succession. The spacing between logs should be at least 6 to 7 feet. The formation can be straight, curved, zigzagged or raised.
2. Opening, passing through and closing a hinged swinging gate (not a rope gate): Use gate that will not endanger horse or rider and requires minimum side-passing.
3. Ride over wooden bridge: Bridge should be sturdy, safe and negotiated at a walk only. Heavy plywood lying flat on the ground is an acceptable simulation of a bridge. Suggested minimum width shall be 36 inches wide and at least 6 feet long.
4. Backing obstacles: Backing obstacles are to be spaced at a minimum of 28 inches. If elevated, 30 inch spacing is required. Back through and around at least three markers. Back through L, V, U or straight or similarly shaped course which may be elevated no more than 24 inches.
5. Side-pass obstacle: Any object which is safe and of any length may be used to demonstrate responsiveness of the horse to leg signals. Raised side pass obstacles should not exceed 12 inches.
6. Drag an object: For open and amateur classes ONLY. The drag is not to be used in any youth, or Rookie/Level 1 amateur classes. Drag may be a complete figure eight and may begin in either direction. The exhibitor must have the rope dallied on the saddle horn (half or full dally) or attached to a fixed ring near the cinch (international events only) for the duration of the drag.

**S18D OPTIONAL OBSTACLES.** Optional obstacles may be used provided the obstacles can be found in everyday ranch work. Optional obstacles from which selections can be made include, but are not limited to:

- A jump obstacle whose center height is not less than 14 inches high or more than 25 inches high and is at least 5 feet from side to side at the approach. Holding the saddle horn is permissible for this obstacle.
- Only live or stuffed animals which would normally be encountered in an outdoor setting may be used but not to be used in an attempt to spook a horse.
- Carry object from one part of the arena to another.
- Remove and replace materials from a mailbox.
- Trot through cones spaced a minimum of 6 feet apart.

- Cross natural ditches or ride up embankments.
- Swing rope or throw rope at a dummy steer head.
- Step in and out of obstacle.
- Put on slicker or coat.
- Stand to mount with mounting block.
- Walk through water obstacle.
- Open gate on foot.
- Pick up feet.
- Walk through brush.
- Ground tie (hobbles are allowed).
- Lead at the trot.

**S18E CREDITS AND PENALTIES.** All runs begin upon entering the area of competition and any infractions are subject to penalty at that time (such as two hands on the reins, using either hand to instill fear, etc.). The rider has the option of eliminating any obstacle, however this will result in being off pattern (OP) and the horse/rider team may not place above others who have completed the pattern correctly. A judge may ask a horse to pass on an obstacle after three refusals or at any time for safety concerns.

Credit is given to horse/rider teams who negotiate the obstacles correctly and efficiently. Horses should receive credit for showing attentiveness to obstacles and ability to negotiate through the course when the obstacles warrant it while willingly responding to rider's cues on more difficult obstacles. Quality of movement and cadence should be considered part of the maneuver score for the obstacle. Natural ranch horse appearance will also be evaluated ranging from plus 1 ½ to minus 1 ½. Maneuver evaluations and penalty applications are to be determined independently. The following penalties will be applied to each occurrence and be deducted from the final score:

**One (1) point**

Over-bridled (per maneuver)

Out of frame (per maneuver)

Each hit, bite or stepping on a log, cone plant or any component of the obstacle

Incorrect or break of gait at walk or trot for two (2) strides or less

Both front or hind feet in a single-stride slot or space at a walk or trot

Skipping over or failing to step into required space

Split pole in lope-over

Incorrect number of strides, if specified

One to two steps on mount/dismount or ground tie except shifting to balance

Wrong lead or out of lead for two (2) strides or less

**Three (3) points**

Wrong lead or out of lead for more than two (2) strides

Draped reins

Break of gait at lope, except when correcting an incorrect lead

Break of gait at walk or trot for more than two (2) strides

Three to four steps on mount/dismount on ground tie

Trotting for more than three (3) strides in lope departures or exiting a rollback into a lope from a stop or walk

Knocking down or over, or severely disturbing an obstacle

Stepping out of or falling off an obstacle with one (1) foot

Missing or evading part of a log/obstacle with one (1) foot

**Five (5) points** Spurring in front of cinch

Blatant disobedience

Use of either hand to instill fear

Stepping out of or falling off an obstacle with more than one (1) foot

Dropping an object required to be carried

1st or 2nd cumulative refusal

Letting go of gate

Five or more steps on mount/dismount or ground tie

Missing or evading part of a log/obstacle with more than one foot

**Off-Pattern (OP)** - Exhibitors cannot place above others who complete pattern correctly

Incomplete maneuver

Eliminating or adding a maneuver

3rd refusal

Repeated blatant disobedience, and failure to dally and remain dallied

Use of two hands (except junior shown in a snaffle bit/hackamore), more than one finger

Between split reins or any fingers between romal reins (except in the two-rein)

Failure to open and shut gate, or failure to complete gate

**Disqualified 0 – Score**

Lameness

Abuse

Leaving working area before pattern is complete

Illegal equipment

Disrespect or misconduct

Improper western attire

Fall of horse/rider

**S19 RANCH PLEASURE ON THE RAIL**

This class measures the ability of the horse to be a pleasure to ride and should reflect the versatility, attitude, and movement of a working horse. The horse should be well-broke, relaxed, quiet, soft and cadenced at all gaits. The movement of the working western rail horse should simulate a horse needing to cover long distances, softly and quietly. The overall manners and responsiveness of the horse and the horse's quality of movement are the primary considerations. Maximum credit should be given to the horse that has a natural flowing stride and consistent, ground covering gaits. Transitions should be performed when requested, with smoothness and responsiveness. The ideal working western rail horse should have a natural head carriage at each gait. The horse should be ridden on a relatively loose rein with light contact and without requiring undue restraint while being responsive to the rider and making timely transitions in a smooth and correct manner. The horse should be soft in the bridle, yield to contact and shall not be shown on a full drape of rein. Riders are encouraged to use adequate space given the extension of gaits required. This class should show the horse's ability to work at a forward, working pace while under control by the rider. The horse shall be balanced and appear willing and a pleasure to ride in a group situation.

Open to horses three years of age and older. Offered as a junior, senior, or all age open division class, and as an all-age class for youth.

No horse may cross enter a western pleasure or walk/trot western pleasure and ranch pleasure on the rail class at the same show regardless of division (youth, amateur or open).

**S19A Class Requirements**

All exhibitors will work as a group. Individuals working off the rail will not be penalized and passing is permissible.

Horses must work both ways of the ring at the walk, trot and lope. Horses must work at least one way of the ring at the extended trot and extended lope. At the option of the judge, horses may be asked to extend their stride at the walk.

The overall cadence and performance of the gaits should be as those described in S13C above with an emphasis on forward, free-flowing and ground-covering movement.

At the extended trot and lope, the exhibitor may post or stand in the stirrups.

Touching or holding the saddle horn during any extended gait is acceptable.

Horses are to be reversed to the inside (away from the rail). They may be required to reverse at the walk or trot at the discretion of the judge but shall not be asked to reverse at the lope.

Horses are required to back easily and stand quietly. Horses may be brought to the center or backed on the rail.

The rider shall not be required to dismount except in the event the judge wishes to check equipment.

**S19B Faults scored according to severity:**

Too slow (any gait)

Excessive speed (any gait)

Over-bridled (nose behind the vertical)

Head carried too low such that the poll is below the withers

Out of frame

Head carried too high

Break of gait

Wrong lead or out of lead

Failure to take the appropriate gait when called

Opening mouth excessively

Draped reins

Use of spurs forward of the cinch

Canted at the lope

Blatant disobedience (kick, bite, buck, rear, etc.)

Faults which will be cause for disqualification: Head carried too low and/or clearly behind the vertical excessively and consistently while the horse is in motion, or otherwise showing the appearance of intimidation.

## **S20 REINING.**

Reining is a judged event designed to show the athletic ability of a ranch type horse in the confines of a show arena. In reining competition, contestants are required to run one of several approved patterns. Each pattern includes small slow circles, large fast circles, flying lead changes, rollbacks over the hocks, a series of 360 degree spins done in place, and the exciting sliding stops that are the hallmark of the reining horse. To rein a horse is not only to guide him, but also to control his every movement. The best reined horse should be willingly guided or controlled with little or no apparent resistance and dictated to completely. Any movement on his own must be considered a lack of control. Any one of the 20 approved reining patterns may be used and is to be selected by the judge of the class and used by all contestants in the class. Each contestant will perform the required pattern individually and separately. All horses will be judged immediately upon entering the arena. Any fault incurred prior to the commencement of a pattern will be scored accordingly. All deviations from the exact written pattern must be considered a lack of or temporary loss of control, and therefore faulted according to severity of deviation. Credit will be given for smoothness, finesse, attitude, quickness and authority in performing the various maneuvers while using controlled speed.

### **S20A SCORING.**

Scoring will be on the basis of 0 to infinity, with 70 denoting an average performance. Points will be added or subtracted from the maneuvers on the following basis, ranging from plus 1 1/2 to minus 1 1/2: -1 1/2 extremely poor, -1 very poor, -1/2 poor, 0 average, +1/2 good, +1 very good, +1 1/2 excellent. Maneuver scores are to be determined independently of penalty points.

#### **The following will result in no score:**

Abuse of an animal in the show arena and/or evidence that an act of abuse has occurred prior to or during the exhibition of a horse in competition;

Failure to wear appropriate western attire;

Use of illegal equipment, including wire on bits, bosals or curb chains;

Use of illegal bits, bosals or curb chains; when using a snaffle bit, optional curb strap is acceptable; however, curb chains are not acceptable.

Use of tack collars, tie downs or nose bands;

Use of whips or bats;

Use of any attachment which alters the movement of or circulation to the tail;

Failure to dismount and/or present horse and equipment to the appropriate judge for inspection;

Disrespect or misconduct by the exhibitor;

Closed reins are not allowed except as standard romal reins and mecates on bosals in classes where the use of two hands is allowed.

Excess rein may be straightened anytime during the pattern, provided the rider's free hand remains behind the rein hand. Any attempt to alter tension or length of the reins from bridle to the rein hand is to be considered use of two hands a penalty score of zero will be applied. In addition, should the judge determine the free hand is being used to instill fear or praise, a penalty five will be applied, and a reduction in the maneuver score.

**The following will result in a score of 0:**

Use of more than index or first finger between reins;

Use of two hands (exception in junior, snaffle bit, or hackamore classes designated for two hands) or changing hands; Use of romal other than as outlined in equipment. Failure to complete pattern as written:

Performing the maneuvers other than in specified order or exceeding greater than one quarter of the circle out of order;

The inclusion of maneuvers not specified, including, but not limited to:

Backing more than two (2) strides;

Turning more than ninety (90) degrees;

On run in patterns, once beginning a lope, a complete stop prior to reaching the first marker. (Exception: a complete stop in the 1st quarter (1/4) of a circle after a lope departure is not to be considered an inclusion of maneuver; a two (2) point break of gait penalty will apply.)

Equipment failure that delays completion of pattern; including dropping a rein that contacts the ground while horse is in motion; Balking or refusal of command where performance is delayed;

Running away or failing to guide where it becomes impossible to discern whether the entry is on pattern;

Jogging in excess of one-half circle or one-half the length of the arena;

Overspins of more than 1/4 turn;

Fall to the ground by horse or rider;

When going to and coming out of a rollback in a pattern requiring a run-around, a rollback that crosses the center line;

Neither a no score nor a 0 is eligible to place in a go round or class single go around class, but a 0 may advance in a multi-go event while a no score may not.

**The following will result in a reduction of five points:**

Spurring in front of cinch;

Use of either hand to instill fear or praise;

Holding saddle with either hand;

Blatant disobediences including kicking, biting, bucking, rearing and striking;

Horse dropping to its knees or hocks.

**The following will result in a reduction of two points:**

Break of gait;

Freeze up in spins or rollbacks;

On walk-in patterns, loping prior to reaching the center of the arena and/or failure to stop or walk before executing a lope departure;

On run-in patterns, failure to be in a lope prior to the first marker or break of gait prior to the first marker;

If a horse does not completely pass the specified marker before initiating a stop position.

Starting or performing circles or eights out of lead will be judged as follows:

Each time a horse is out of lead, a judge is required to penalize by one point. The penalty for being out of lead is cumulative and the judge will deduct one penalty point for each one quarter (1/4) of the circumference of a circle or any part thereof that a horse is out of lead. A judge is required to penalize a horse 1/2 point for a delayed change of lead by one stride where the lead change is required by the pattern description.

Deduct 1/2 point for starting circle at a jog or exiting rollbacks at a jog up to two strides. Jogging beyond two strides, but less than 1/2 circle or 1/2 the length of the arena, deduct two points.

Deduct 1/2 point for over or under spinning up to 1/8 of a turn; deduct one point for over or under spinning 1/8 to 1/4 turn. A horse can only be assessed one over or under spin penalty per maneuver.

A 1/2 point penalty deduction will be given for failure to remain a minimum of 20 feet (6 meters) from the side of the arena when approaching a stop and/or rollback.

In patterns requiring a run-around, failure to be on the correct lead when rounding the end of the arena will be penalized as follows:

From the turn to the half-way position at end wall, one (1) point

Beyond the half-way point to the beginning of the run down, two (2) points

In a pattern requiring a run-around, there will be a one half (1/2) point penalty for failure to remain a minimum of 10 feet from either side of the center of the arena; for small arenas it will be at the judge's discretion.

A horse which severely stumbles, significantly detracting from the maneuver shall have the maneuver reduced by one half (1/2) point.

Faults against the horse to be scored accordingly, but not to cause disqualification:

Opening mouth excessively when wearing bit;

Excessive jawing, opening mouth or head raising on stop;

Lack of smooth, straight stop on haunches-bouncing or sideways stop;

Refusing to change leads;

Anticipating signals;

Stumbling; Backing sideways;

Knocking over markers.

If only one reining class is to be held at a show, it shall be reining - all ages - horses 6 years old and older must be shown in bit; horses 5 years old and younger may be shown in either bit, hackamore or snaffle bit at the discretion of the exhibitor.

Patterns shall be selected from patterns 1-15 of the AQHA reining patterns as published in the current year rulebook.

Show managers must provide the pattern at least one hour before the class, however providing the pattern well in advance is acceptable.



## REINING PATTERN 2

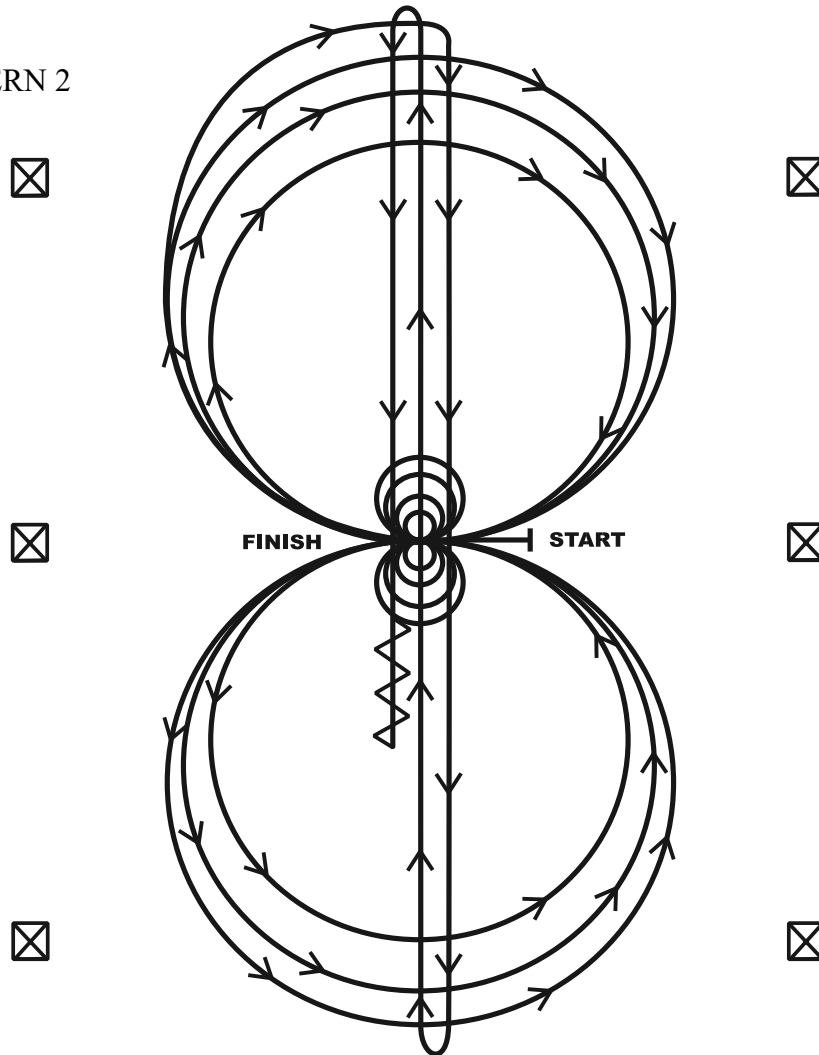

Horses may walk or jog to the center of arena. Horses must walk or stop prior to starting pattern. Beginning at the center of the arena facing the left wall or fence.

1. Beginning on the right lead, complete three circles to the right: the first circle small and slow; the next two circles large and fast. Change leads at the center of the arena.
2. Complete three circles to the left: the first circle small and slow; the next two circles large and fast. Change leads at the center of the arena.
3. Continue around previous circle to the right. At the top of the circle, run down the middle to the far end of the arena past the end marker and do a right rollback—no hesitation.
4. Run up the middle to the opposite end of the arena past the end marker and do a left rollback—no hesitation.
5. Run past the center marker and do a sliding stop. Back up to the center of the arena or at least ten feet (three meters). Hesitate.
6. Complete four spins to the right. Hesitate.
7. Complete four spins to the left. Hesitate to demonstrate the completion of the pattern.

## REINING PATTERN 3

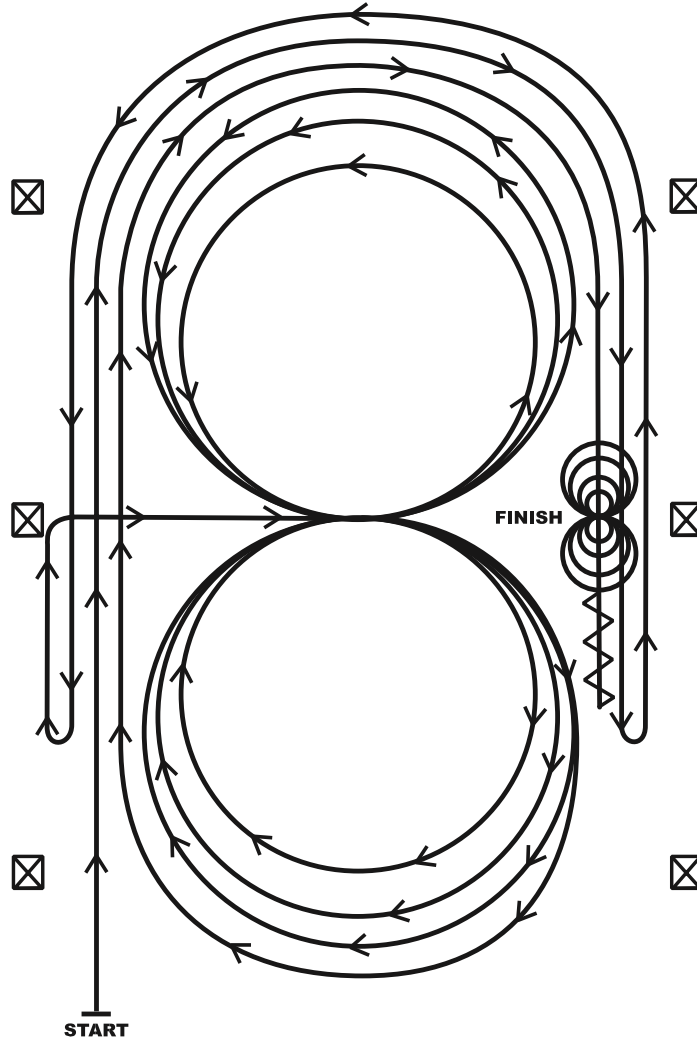

1. Beginning, lope straight up the left side of the arena, circle the top end of the arena, and staying at least twenty feet (six meters) from the walls or fence, run straight down the opposite or right side of the arena past the center marker and do a left rollback—no hesitation.
2. Continue straight up the right side of the arena circle back around the top of the arena, and staying at least twenty feet (six meters) from the walls or fence, run straight down the left side of the arena past the center marker and do a right rollback—no hesitation.
3. Continue up the left side of the arena to the center marker. At the center marker, the horse should be on the right lead. Guide the horse to the center of the arena on the right lead and complete three circles to the right: the first two circles large and fast; the third circle small and slow. Change leads at the center of the arena.
4. Complete three circles to the left: the first two circles large and fast; the third circle small and slow. Change leads in the center of the arena.
5. Begin a large circle to the right but do not close this circle. Continue up the left side of the arena, circle the top of the arena, and staying at least twenty feet (six meters) from the walls or fence, run straight down the opposite or right side of the arena past the center marker and do a sliding stop. Back up at least ten feet (three meters). Hesitate.
6. Complete four spins to the right. Hesitate.
7. Complete four spins to the left. Hesitate to demonstrate completion of the pattern.

## REINING PATTERN 4

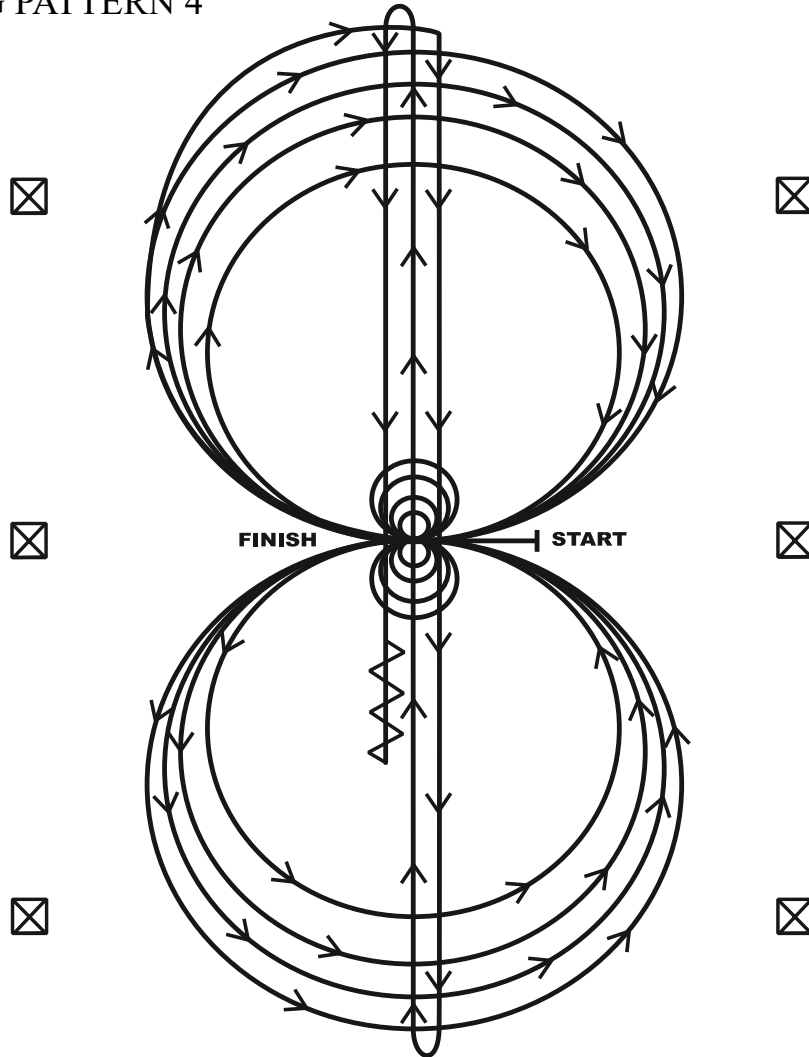

Horses may walk or jog to the center of the arena. Horses must walk or stop prior to starting pattern. Beginning at the center of the arena facing the left wall or fence.

1. Beginning on the right lead, complete three circles to the right: the first two large and fast; the third circle small and slow. Stop at the center of the arena. Hesitate.
2. Complete four spins to the right. Hesitate.
3. Beginning on the left lead, complete three circles to the left: the first two circles large and fast; the third circle small and slow. Stop at the center of the arena. Hesitate.
4. Complete four spins to the left. Hesitate.
5. Beginning on the right lead, run a large fast circle to the right, change leads at the center of the arena, run a large fast circle to the left, and change leads at the center of the arena. (Figure 8)
6. Continue around previous circle to the right. At the top of the circle, run down the middle to the far end of the arena past the end marker and do a right rollback—no hesitation.
7. Run up the middle to the opposite end of the arena past the end marker and do a left rollback—no hesitation.
8. Run past the center marker and do a sliding stop. Back up to the center of the arena or at least ten feet (three meters). Hesitate to demonstrate completion of the pattern.

## REINING PATTERN 5

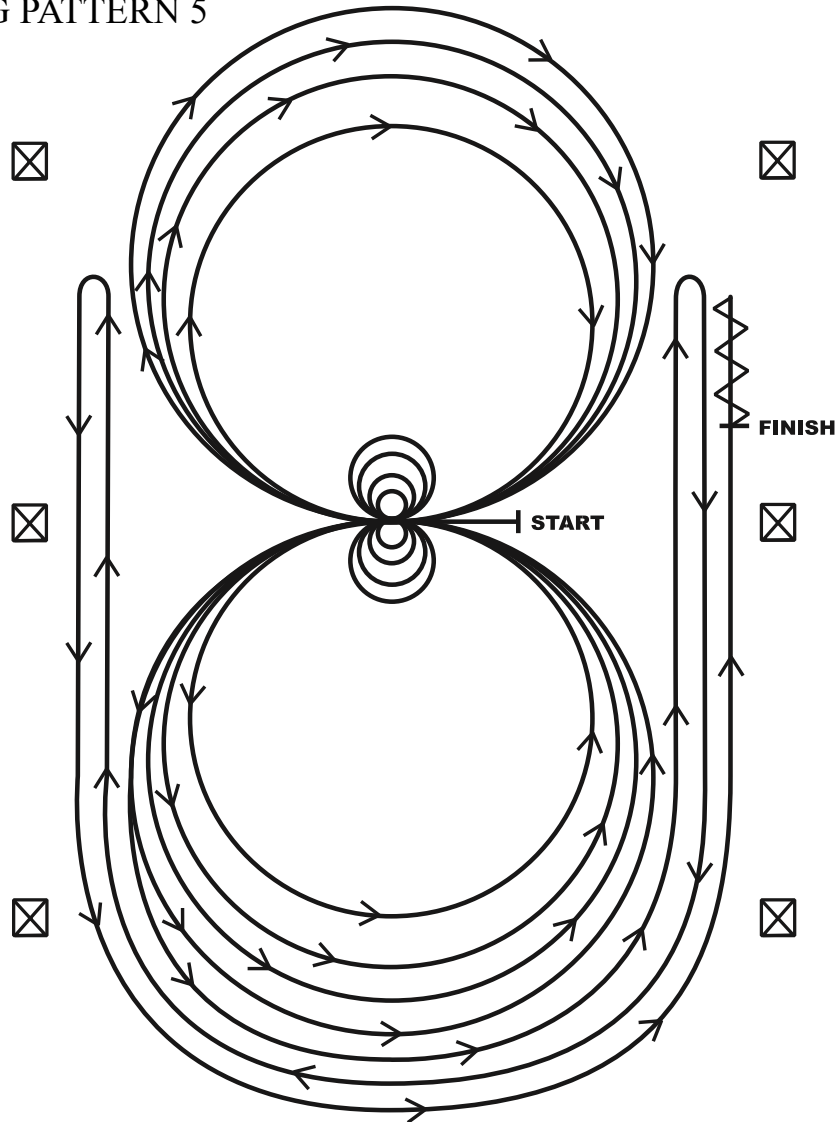

Horses may walk or jog to the center of arena. Horses must walk or stop prior to starting pattern. Beginning at the center of the arena facing the left wall or fence.

1. Beginning on the left lead, complete three circles to the left: the first two circles large and fast; the third circle small and slow. Stop at the center of the arena. Hesitate.
2. Complete four spins to the left. Hesitate.
3. Beginning on the right lead, complete three circles to the right: the first two circles large and fast; the third circle small and slow. Stop at the center of the arena. Hesitate.
4. Complete four spins to the right. Hesitate.
5. Beginning on the left lead, run a large fast circle to the left, change leads at the center of the arena, run a large fast circle to the right, and change leads at the center of the arena. (Figure 8)
6. Continue around previous circle to the left but do not close this circle. Run up the right side of the arena past the center marker and do a right rollback at least twenty feet (six meters) from the wall or fence—no hesitation.
7. Continue around previous circle but do not close this circle. Run up the left side of the arena past the center marker and do a left rollback at least twenty feet (six meters) from the wall or fence—no hesitation.
8. Continue back around previous circle but do not close this circle. Run up the right side of the arena past the center marker and do a sliding stop at least twenty feet (six meters) from the wall or fence. Back up at least ten feet (three meters). Hesitate to demonstrate completion of the pattern.

## REINING PATTERN 6

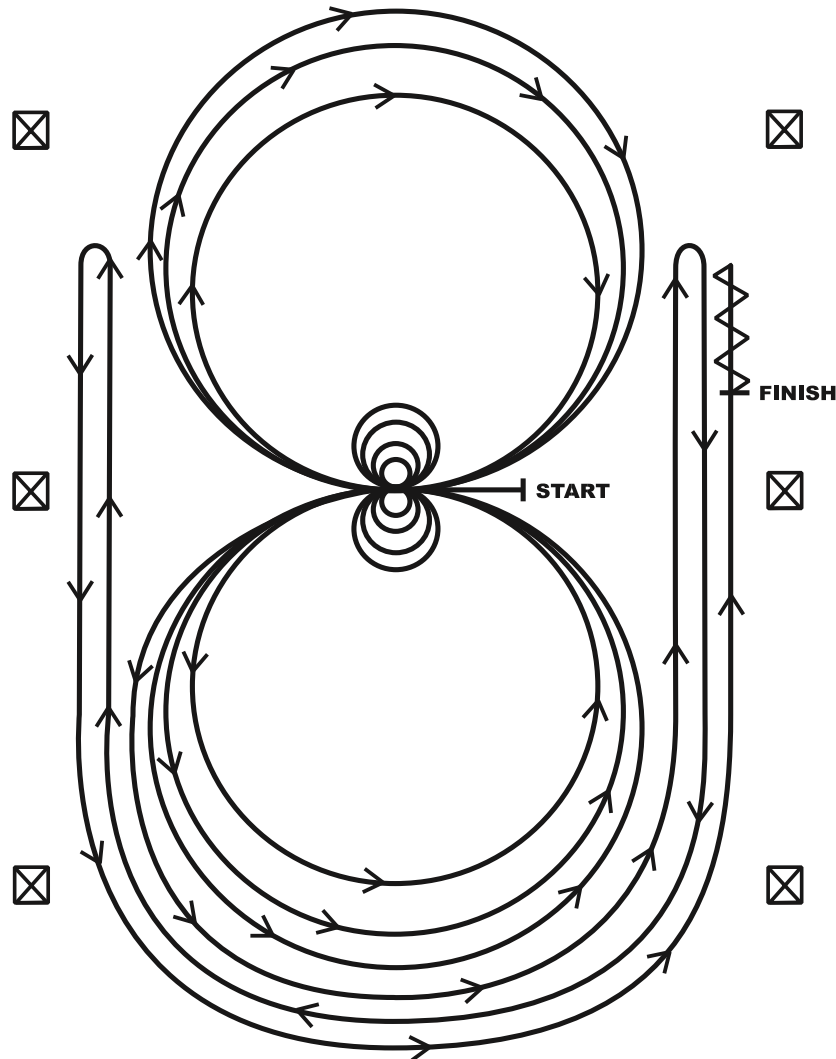

Horses may walk or jog to the center of arena. Horses must walk or stop prior to starting pattern. Beginning at the center of the arena facing the left wall or fence.

1. Complete four spins to the right. Hesitate.
2. Complete four spins to the left. Hesitate.
3. Beginning on the left lead, complete three circles to the left: the first two circles large and fast; the third circle small and slow. Change leads at the center of the arena.
4. Complete three circles to the right: the first two circles large and fast; the third circle small and slow. Change leads at the center of the arena.
5. Begin a large circle to the left but do not close this circle. Run up the right side of the arena past the center marker and do a right rollback at least twenty feet (six meters) from the wall or fence—no hesitation.
6. Continue back around previous circle but do not close this circle. Run up the left side of the arena past the center marker and do a left rollback at least twenty feet (six meters) from the wall or fence—no hesitation.
7. Continue back around previous circle but do not close this circle. Run up the right side of the arena past the center marker and do a sliding stop at least twenty feet (six meters) from the wall or fence. Back up at least ten feet (three meters). Hesitate to demonstrate the completion of the pattern.

## REINING PATTERN 7

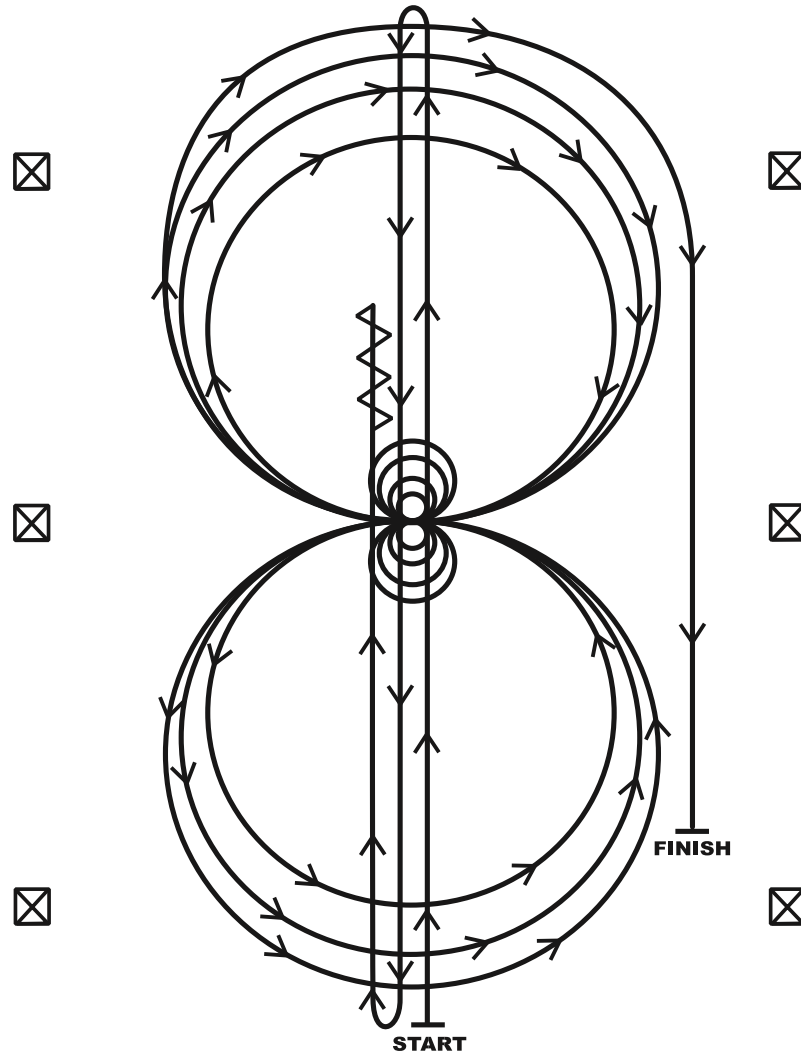

1. Run at speed to the far end of the arena past the end marker and do a left rollback—no hesitation.
2. Run to the opposite end of the arena past the end marker and do a right rollback—no hesitation.
3. Run past the center marker and do a sliding stop. Back up to the center of the arena or at least ten feet (three meters). Hesitate.
4. Complete four spins to the right. Hesitate.
5. Complete four and one-quarter spins to the left so that horse is facing left wall or fence. Hesitate.
6. Beginning on the right lead, complete three circles to the right: the first two circles large fast; the third circle small and slow. Change leads at the center of the arena.
7. Complete three circles to the left: the first two circles large fast; the third circle small and slow. Change leads at the center of the arena.
8. Begin a large circle to the right but do not close this circle. Run straight down the right side of the arena past the center marker and do a sliding stop at least twenty feet (six meters) from the wall or fence. Hesitate to demonstrate completion of the pattern.

## REINING PATTERN 8

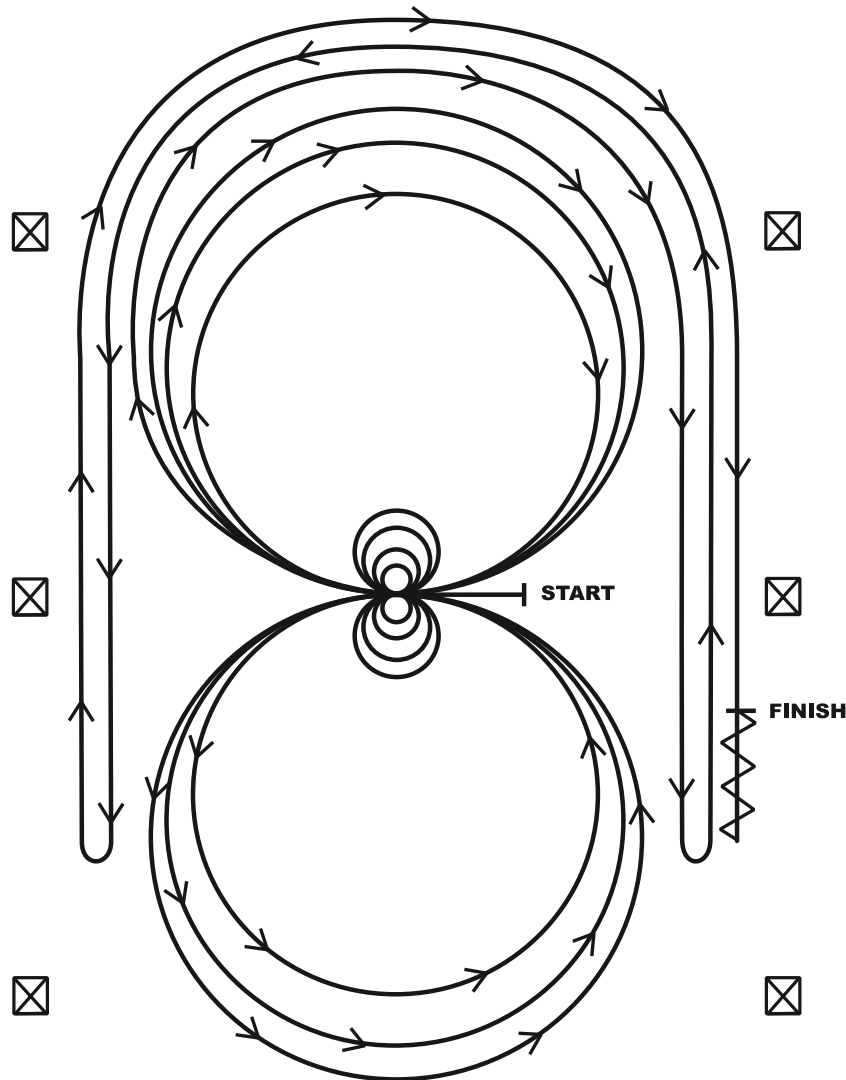

Horses may walk or jog to the center of arena. Horses must walk or stop prior to starting pattern. Beginning at the center of arena facing the left wall or fence.

1. Complete four spins to the left. Hesitate.
2. Complete four spins to the right. Hesitate.
3. Beginning on the right lead, complete three circles to the right: the first circle large and fast; the second circle small and slow; the third circle large and fast. Change leads at the center of the arena.
4. Complete three circles to the left: the first circle large and fast; the second circle small and slow; the third circle large and fast. Change leads at the center of the arena.
5. Begin a large circle to the right but do not close this circle. Run straight down the right side of the arena past the center marker and do a left rollback at least twenty feet (six meters) from the wall or fence—no hesitation.
6. Continue back around the previous circle but do not close this circle. Run down the left side of the arena past the center marker and do a right rollback at least twenty feet (six meters) from the wall or fence—no hesitation.
7. Continue back around the previous circle but do not close this circle. Run down the right side of the arena past the center marker and do a sliding stop at least twenty feet (six meters) from the wall or fence. Back up at least ten feet (three meters). Hesitate to demonstrate completion of the pattern.

## REINING PATTERN 9

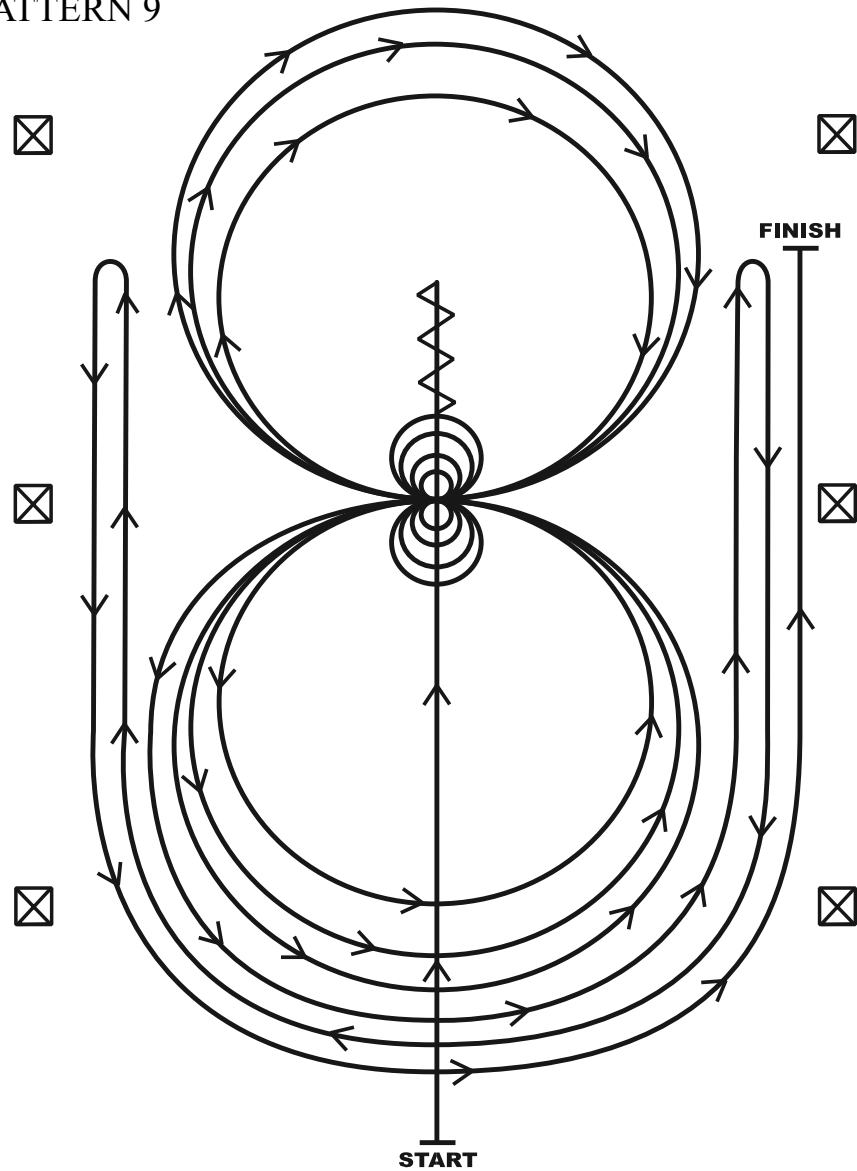

1. Run past the center marker and do a sliding stop. Back up to the center of the arena or at least ten feet (three meters). Hesitate.
2. Complete four spins to the right. Hesitate.
3. Complete four and one-quarter spins to the left so that horse is facing the left wall or fence. Hesitate.
4. Beginning on the left lead, complete three circles to the left: the first circle small and slow; the next two circles large and fast. Change leads at the center of the arena.
5. Complete three circles to the right: the first circle small and slow; the next two circles large and fast. Change leads at the center of the arena.
6. Begin a large circle to the left but do not close this circle. Run up the right side of the arena past the center marker and do a right rollback at least twenty feet (six meters) from the wall or fence—no hesitation.
7. Continue back around the previous circle but do not close this circle. Run up the left side of the arena past the center marker and do a left rollback at least twenty feet (six meters) from the wall or fence—no hesitation.
8. Continue back around previous circle but do not close this circle. Run up right side of the arena past the center marker and do a sliding stop at least twenty feet (six meters) from the wall or fence. Hesitate to demonstrate completion of the pattern.

## REINING PATTERN 10

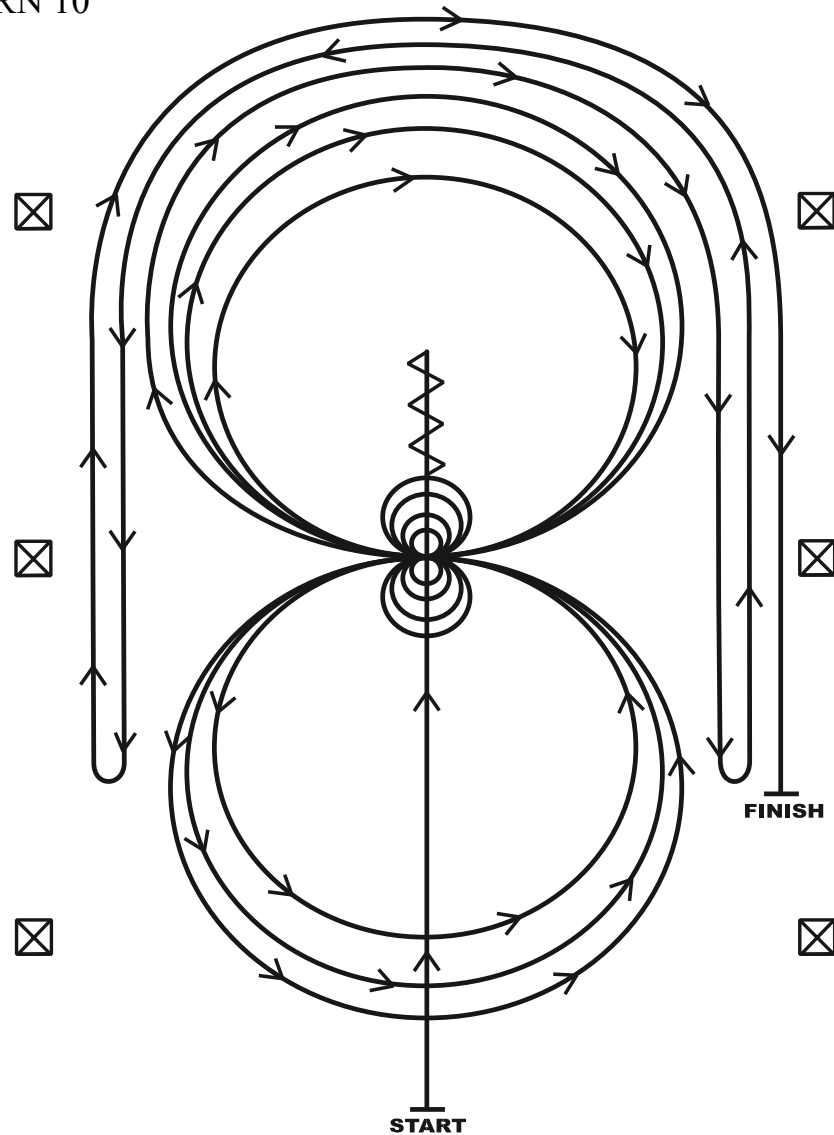

1. Run past the center marker and do a sliding stop. Back up to the center of the arena or at least ten feet (three meters). Hesitate.
2. Complete four spins to the right. Hesitate.
3. Complete four and one-quarter spins to the left so that the horse is facing the left wall or fence. Hesitate.
4. Beginning on the right lead, complete three circles to the right: the first two circles large and fast, the third circle small and slow. Change leads at the center of the arena.
5. Complete three circles to the left: the first circle small and slow, the next two circles large and fast. Change leads at the center of the arena.
6. Begin a large circle to the right but do not close this circle. Run down the right side of the arena past the center marker and do a left rollback at least twenty feet (six meters) from the wall or fence—no hesitation.
7. Continue back around the previous circle but do not close this circle. Run down the left side of the arena past the center and do a right rollback at least twenty feet (six meters) from the wall or fence—no hesitation.
8. Continue back around previous circle but do not close this circle. Run down the right side of the arena past the center marker and do a sliding stop at least twenty feet (six meters) from the wall or fence. Hesitate to demonstrate completion of the pattern.

## REINING PATTERN 11

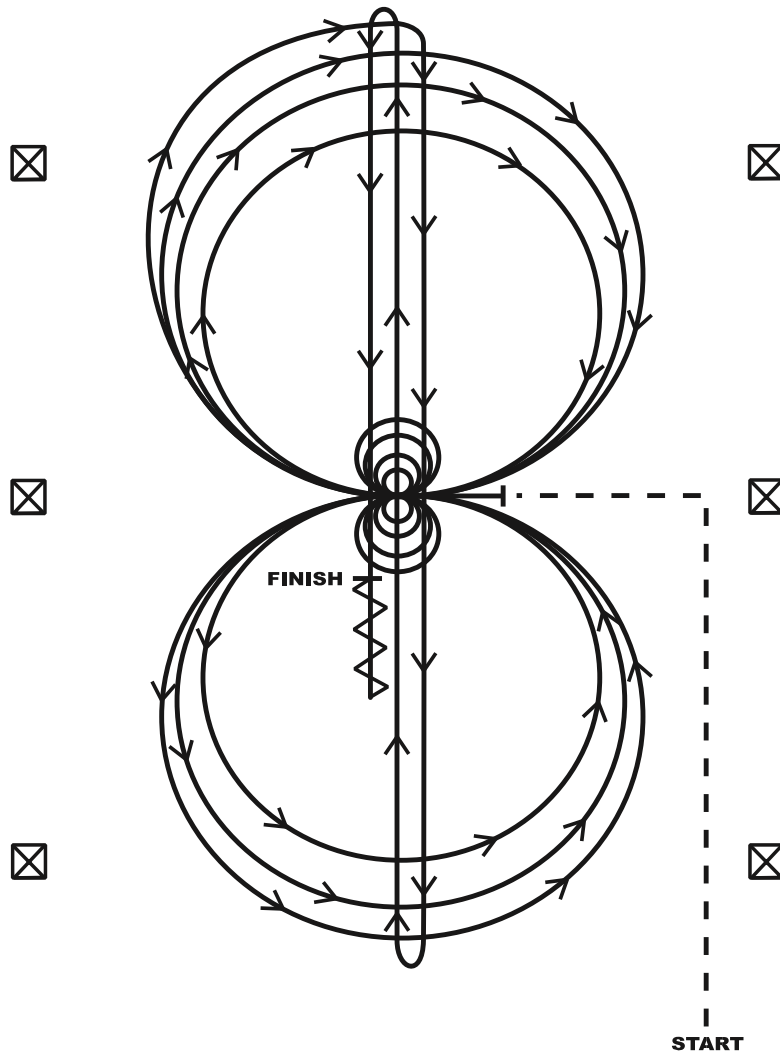

Horses must jog the majority of the way (over  $\frac{1}{2}$  the distance) to the center of the arena. Horses must walk or stop prior to starting the pattern. Beginning at the center of the arena facing the left wall or fence.

1. Complete four spins to the left. Hesitate.
2. Complete four spins to the right. Hesitate.
3. Beginning on the right lead complete three circles to the right; the first circle small and slow; the next two circles large and fast. Change leads at the center of the arena.
4. Complete three circles to the left; the first circle small and slow; the next two circles large and fast. Change leads at the center of the arena.
5. Begin a large circle to the right, but do not close this circle. Run down the center of the arena past the end marker and do a right rollback—no hesitation.
6. Run up the middle to the opposite end of the arena past the end marker and do a left rollback—no hesitation.
7. Run past the center marker and do a sliding stop. Back up to the center of the arena or at least ten feet (three meters). Hesitate to demonstrate completion of the pattern.

## REINING PATTERN 12

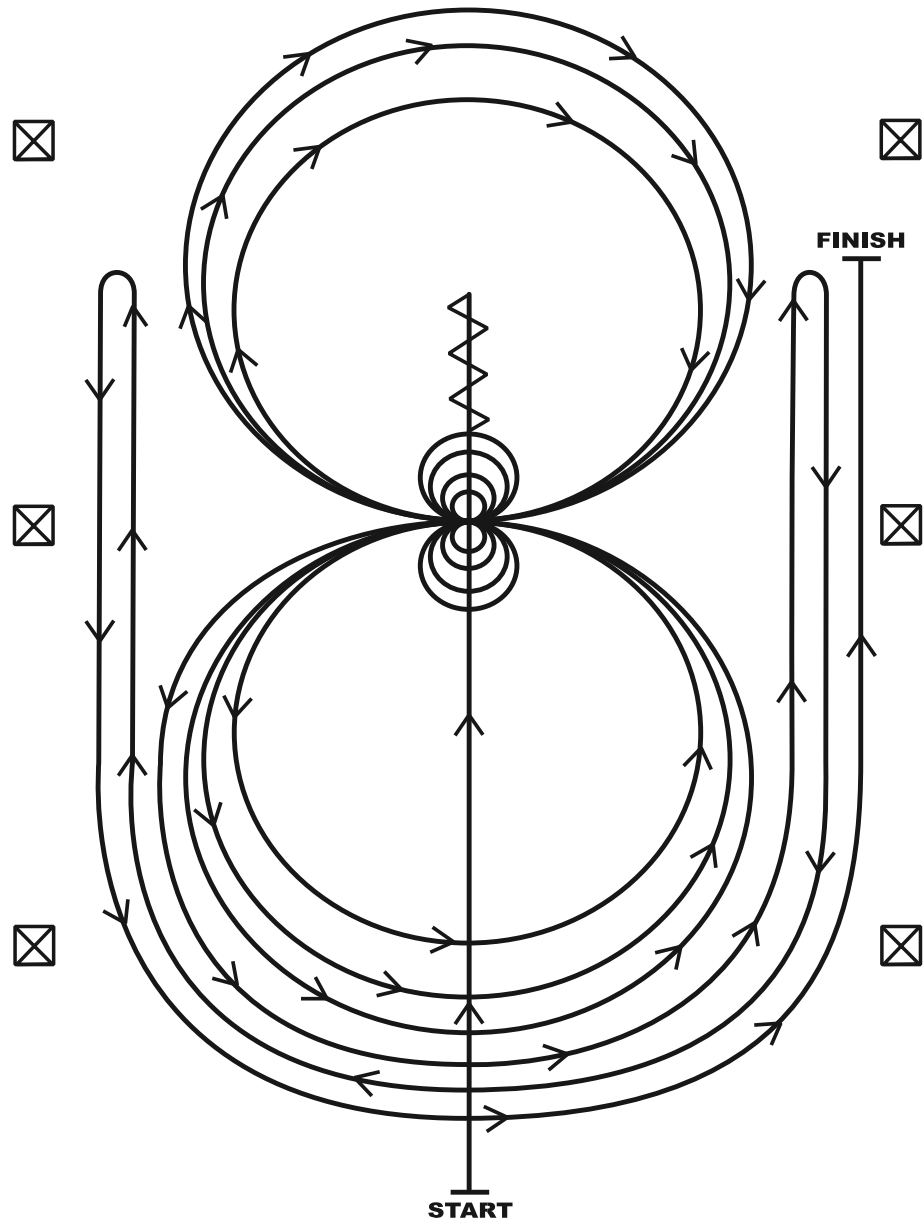

1. Run past the center marker and do a sliding stop. Back up to the center of the arena or at least 10 feet (3 meters). Hesitate.
2. Complete four spins to the right. Hesitate.
3. Complete four and one-quarter spins to the left so that the horse is facing the left wall or fence. Hesitate.
4. Beginning on the left lead, complete three circles to the left: the first two circles large and fast; the third circle small and slow. Change leads at the center of the arena.
5. Complete three circles to the right: the first two circles large and fast; the third circle small and slow. Change leads at the center for the arena.
6. Begin a large circle to the left but do not close this circle. Run up the right side of the arena past the center marker and do a right rollback at least 20 feet (6 meters) from the wall or fence-no hesitation.
7. Continue back around previous circle but do not close this circle. Run up the left side of the arena and past the center marker and do a left rollback at least 20 feet (6 meters) from the wall or fence-no hesitation.
8. Continue back around previous circle but do not close this circle. Run up the right side of the arena past the center marker and do a sliding stop at least 20 feet (6 meters) from the wall or fence. Hesitate to demonstrate completion of pattern.

## REINING PATTERN 13

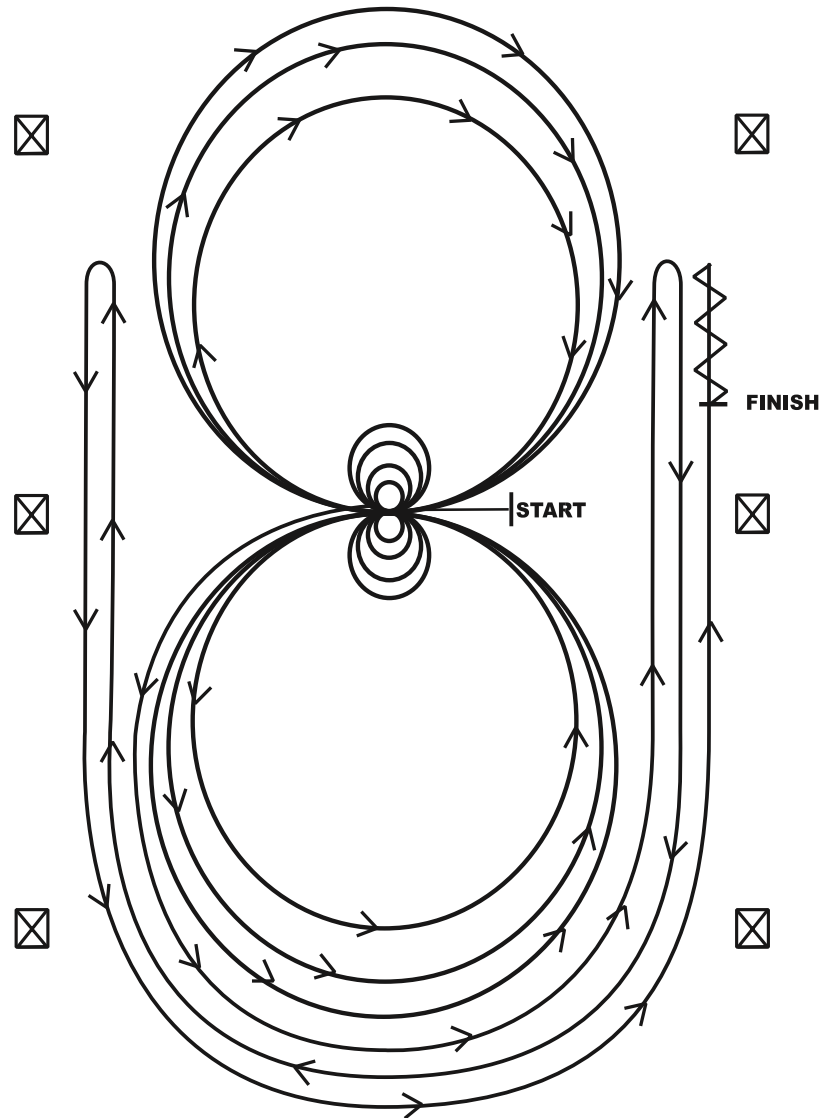

Horses must walk or stop prior to starting pattern. Beginning at the center of the arena facing the left wall or fence.

1. Beginning on the left lead, complete two circles to the left: the first circle large and fast; the second circle small and slow. Stop at the center of the arena
2. Complete four spins to the left. Hesitate.
3. Beginning on the right lead, complete two circles to the right: the first being large and fast; the second circle small and slow. Stop at the center of the arena.
4. Complete four spins to the right. Hesitate.
5. Beginning on the left lead, run a large fast circle to the left, change leads at the center of the arena, run a large fast circle to the right, and change leads at the center of the arena.
6. Continue around previous circle to the left but do not close this circle. Run up the right side of the arena past the center marker and do a right rollback at least 20 feet (6 meters) from the wall or fence-no hesitation.
7. Continue around previous circle but do not close this circle. Run up the left side of the arena past the center marker and do a left rollback at least 20 feet (6 meters) from the wall or fence-no hesitation.
8. Continue back around previous circle but do not close this circle. Run up the right side of the arena past the center marker and do a sliding stop at least 20 feet (6 meters) from the wall or fence. Back up at least 10 feet (3 meters). Hesitate to demonstrate completion of pattern.

## REINING PATTERN 14

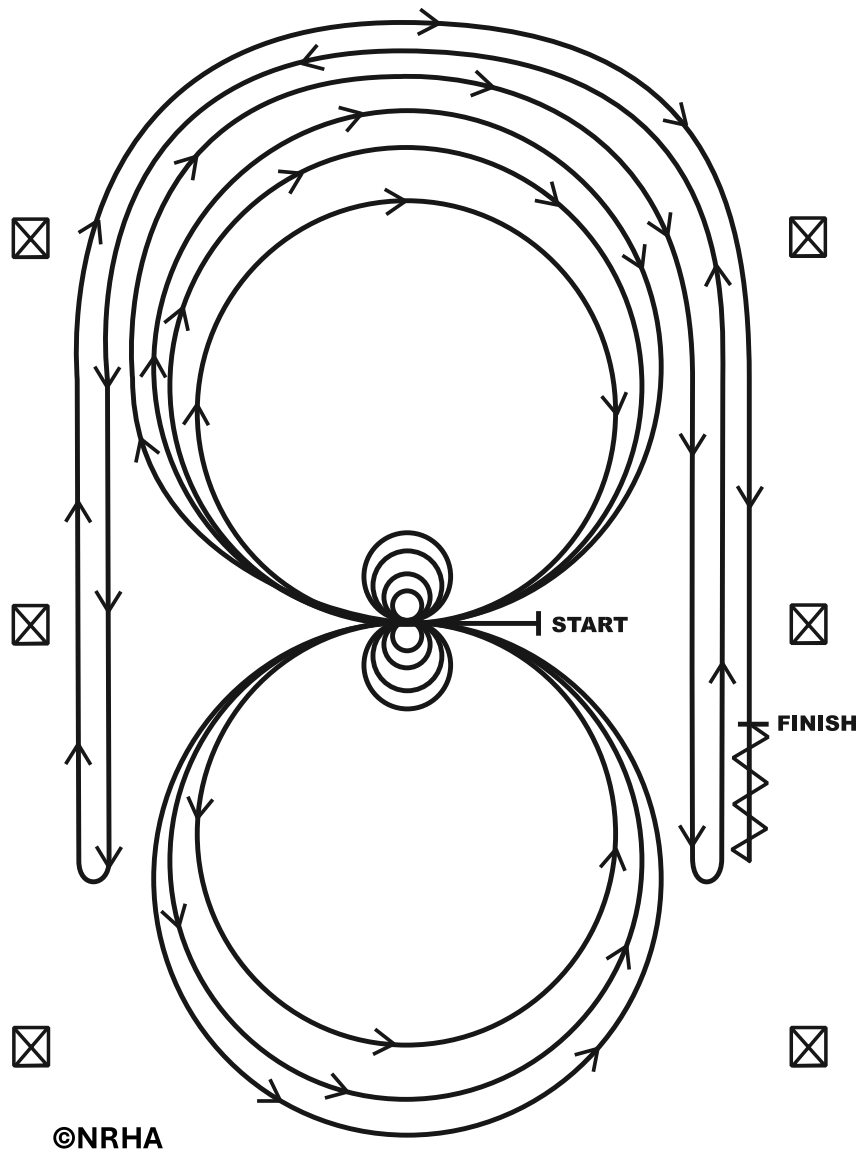

Horses may walk or jog to the center of arena. Horses must walk or stop prior to starting pattern. Beginning at the center of the arena facing the left wall or fence.

1. Complete four spins to the left. Hesitate.
2. Complete four spins to the right. Hesitate.
3. Beginning on the right lead, complete three circles to the right: the first two circles large and fast; the third circle small and slow. Change leads at the center of the arena.
4. Complete three circles to the left: the first two circles large and fast; the third circle small and slow. Change leads at the center of the arena.
5. Begin a large circle to the right but do not close this circle. Run up the right side of the arena past the center marker and do a left rollback at least twenty feet (six meters) from the wall or fence—no hesitation.
6. Continue back around previous circle but do not close this circle. Run up the left side of the arena past the center marker and do a right rollback at least twenty feet (six meters) from the wall or fence—no hesitation.
7. Continue back around previous circle but do not close this circle. Run up the right side of the arena past the center marker and do a sliding stop at least twenty feet (six meters) from the wall or fence. Back up at least ten feet (three meters). Hesitate to demonstrate the completion of the pattern.

## REINING PATTERN 15

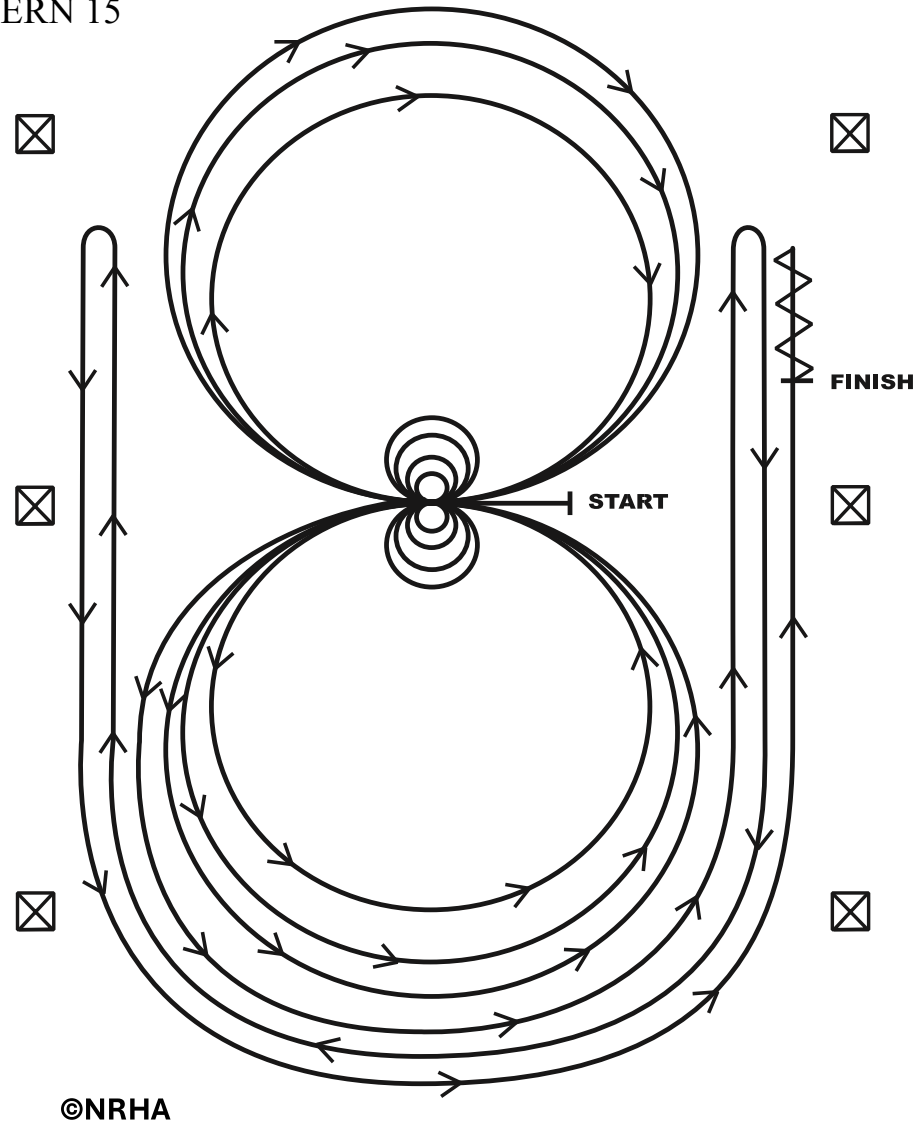

Horses may walk or jog to the center of arena. Horses must walk or stop prior to starting pattern. Beginning at the center of arena facing the left wall or fence.

1. Complete four spins to the right. Hesitate.
2. Complete four spins to the left. Hesitate.
3. Beginning on the left lead, complete three circles to the left: the first circle large and fast; the second circle small and slow; the third circle large and fast. Change leads at the center of the arena.
4. Complete three circles to the right: the first circle large and fast; the second circle small and slow; the third circle large and fast. Change leads at the center of the arena.
5. Begin a large circle to the left but do not close this circle. Run straight down the right side of the arena past the center marker and do a right rollback at least twenty feet (six meters) from the wall or fence—no hesitation.
6. Continue back around the previous circle but do not close this circle. Run down the left side of the arena past the center marker and do a left rollback at least twenty feet (six meters) from the wall or fence—no hesitation.
7. Continue back around the previous circle but do not close this circle. Run down the right side of the arena past the center marker and do a sliding stop at least twenty feet (six meters) from the wall or fence. Back up at least ten feet (three meters). Hesitate to demonstrate completion of the pattern.

## **S21 CUTTING**

The cutting class is a battle of wills between a horse and a cow. Horse and rider must move quietly into a herd of cattle, cut one animal from the herd, drive it to the center of the arena and hold it away from the herd. The cutting horse must match moves with the cow, anticipating its every maneuver. Judges score the horses on their ability to keep the cow from returning to the herd, cow sense, attentiveness and courage. Contestants can cut two head of cattle in the 2 minute time limit.

National Cutting Horse Association rules will be used for conducting and judging cutting. All riders in the arena shall comply with rules on dress, equipment and conduct and be limited to bona fide contestants or their helpers per NCHA rules.

Rules of the National Cutting Horse Association are available from the National Cutting Horse Association, 260 Bailey Avenue, Fort Worth, Texas 76107, [nchacutting.com](http://nchacutting.com)

**S21A Scoring.** Scoring will be on the basis of 60-80, with 70 denoting an average performance.

**Penalties.** Maneuver evaluations and penalty applications are to be determined independently. The following penalties will be applied to each occurrence and be deducted from the final score:

**One-Half (1/2) point**

A slight miss or slight loss of working advantage

**One (1) point**

Miss or loss of working advantage

Reining or visibly cueing

Noise, directed toward cattle

Toe, foot or stirrup on shoulder of horse

Holding on too long on a cut

Working out of position

Hand too far forward

**Three (3) points**

Hot quit

Cattle picked up or scattered

Second hand on the reins

Spur in the shoulder

Pawing or biting cattle

Failure to make a deep cut

Back fence

**Five (5) points**

Horse quitting a cow

Losing a cow

Changing cattle after a specific commitment

Failure to separate a single animal after leaving the herd

**Score of 60** If horse turns tail

**Disqualified (0) – Score**

Illegal equipment

Riding with romal or closed rein on snaffle bit/hackamore

Leaving working area before time expires

Inhumane treatment of horse

If horse falls to ground

**S22 WORKING COW HORSE (COW WORK)**

The ideal ranch horse must also be a cow horse and this class demonstrates and measures the horse's ability to do cow work. Holding the saddle horn is permitted. There is a time limit per horse/rider team to perform the work depending on the division and the time begins when the cow is turned into the arena. If the time has not elapsed and the judge is satisfied that all requirements of the class have been met, the judge should blow the whistle for the exhibitor to cease work. The judge may blow a whistle at any time for the exhibitor to cease work for safety reasons. Judges will give credit for what they have seen. Only the judge may award a new cow to a contestant to replace a cow that will not honor a horse. If the judge awards a new cow, the exhibitor has the option to refuse the new cow by continuing to work. If the exhibitor accepts the new cow, the time for working the cow will start over. If the exhibitor intends to accept the new cow, the exhibitor must pull up immediately. When multiple judges are scoring, any one of the judges may terminate the work or signal for a new cow.

## S22A CONTENT

Exhibitors are allotted three minutes to complete the work. When there is one minute left, the announcer will announce, "One minute remaining." At three minutes, the announcer will call for time. There are three parts to the class: boxing, fence work and circling.

- **Part One** – Boxing the Cow: The rider shall ride into the arena, face the cattle entry gate and signal for their cow to be turned into the arena. The cow shall be controlled on the entry end of the arena for a sufficient amount of time to demonstrate the horse's ability to hold the cow. If the cow does not immediately challenge the horse, the rider shall aggressively move in on the cow to demonstrate his horse's ability to drive and block the cow on the entry fence.
- 
- **Part Two** – Fence Work: After the cow has been controlled on the entry end of the arena, the rider shall set the cow up and drive it down either side of the arena. The cow should be turned on the fence at least once in each direction. To qualify as a turn, the first run out for a turn shall be past the half-way mark of the arena. The exhibitor must be in position to control the animal and be the cause the animal to change course. All turns down the side shall be completed before reaching the end fence.
- 
- **Part Three** –Circling: The exhibitor will circle the cow in the middle of the arena in both directions. To circle the cow, the exhibitor will maneuver the cow smoothly at least 360 degrees in each direction without interference from the fence. The circle's size, symmetry, speed and relative balance from right and left show control. Tightening the circles down with fast head-to-head speed will be a credit situation. The circles should be completed before the cow is exhausted. Once an exhibitor has committed to circling a cow, if the cow falls no new cow will be awarded. The exhibitor will complete the run by riding around the fallen cow to fulfill circling requirements. In the circling portion of the judging, one whistle will terminate the work and two whistles will award a new cow.

## S22B CREDITS AND PENALTIES.

All runs begin upon entering the pen; any infractions (such as two hands on the reins, using either hand to instill fear) are subject to penalty at that time. During Boxing, credit will be given for the horse's expression and its cow sense (i.e., making moves with little rider assistance); holding, controlling, and turning the cow; the amount of work actually done; and the degree of difficulty of the work. Credit will be given during Fence Work for making the first run past the center of the arena; making turns right on the cow; and controlling a difficult cow. For Circling, credit will be given when the horse works willingly; acknowledges the cow; and gets close enough to the cow to control the circles. Credits for Circling range from -1 1/2 to +1 1/2 points for each direction. Maneuver evaluations and penalty applications are to be determined independently. The following penalties will be applied to each occurrence and be deducted from the final score:

- **1 point:** Over-bridled (per maneuver), out of frame (per maneuver), loss of working advantage; Using the corner or the end of the arena to turn the cow when going down the fence; changing sides of arena to turn cow; for each length horse runs past cow; working out of position; slipping rein; failure to drive cow past middle marker on first turn.
- **2 point:** Going around the corner of the arena before turning cow; when working an animal in the open field (at least 20' from the side of arena) and the animal gets within 3 feet from the end fence before being turned.
- **3 point:** Exhausting or overworking the cow before circling or roping; hanging up on the fence (refusing to turn); knocking down the cow without having a working advantage; dangerous position.
- **5 point:** Failure to turn the cow both directions on the fence; spurring in front of cinch; Blatant disobedience; use of either hand to instill fear.
- **Off-Pattern (OP):** Turning tail; failure to attempt any part of the class; repeated blatant disobedience; schooling after entering the arena prior to calling for cow; schooling horse between cows if new cow is awarded; use of two hands (except junior horses shown in a snaffle bit/hackamore), more than one finger between split reins or any fingers between romal reins (except in the two-rein). Cannot place above others who complete pattern correctly.
- **Disqualification (DQ):** bringing the cow straight over backwards landing on its back or head with all four feet in the air, lameness, abuse, illegal equipment, disrespect or misconduct, leaving arena before run is complete; improper western attire; fall of horse/rider; out of control, dangerous or excessive schooling.

## **S23 BOXING**

This class is open to youth and amateur riders only. Exhibitors cannot show in a working cow horse class and a boxing class at the same show.

### **S23A Content.**

Horses, regardless of their age, may be ridden with one hand and a standard western bit as approved by equipment rules or with one or two hands and a snaffle bit or hackamore as described under equipment rules. Exhibitors are allotted 50 seconds to complete the work. The rider shall ride into the arena, face the cattle entry gate, and signal for their cow to be turned into the arena. The cow shall be controlled on the entry end of the arena to demonstrate the horse's ability to hold the cow. If the cow does not immediately challenge the horse, the rider shall aggressively move in on the cow to demonstrate his horse's ability to drive and block the cow.

### **S23B Credits and Penalties**

All runs begin upon entering the pen; any infractions (such as two hands on the reins, using either hand to instill fear) are subject to penalty at that time. During Boxing, credit will be given for the horse's expression and its 'cow sense' (i.e., making moves with little rider

assistance); holding, controlling, and turning the cow; the amount of work actually done; and the degree of difficulty of the work. Penalties will be assessed as follows:

**1 point:** Over-bridled (per maneuver); out of frame (per maneuver); loss of working advantage; working out of position; excessive hollering.

**3 point:** Knocking down the cow without having a working advantage; losing a cow; dangerous position.

**5 point:** Spurring in front of cinch; blatant disobedience; use of either hand to instill fear.

**Off-Pattern (OP):** Turning tail; failure to attempt any part of the class; repeated blatant disobedience; schooling after entering the arena prior to calling for cow; schooling horse between cows (if new cow is awarded); use of two hands (except horses shown in a snaffle bit or hackamore), more than one finger between split reins or any fingers between romal reins (except in the two-rein). Exhibitors cannot place above others who complete the pattern correctly.

**Disqualification (DQ):** lameness, abuse, illegal equipment, disrespect or misconduct, leaving arena before run is complete; improper western attire, fall of horse/rider; out of control, dangerous, or excessive schooling.

## **S24 BARREL RACING.**

When offered, this class is limited to Youth exhibitors only. Exhibitors race against the clock, following a course consisting of three barrels in a triangular “cloverleaf” pattern. Contestants must choose either the right or left barrel, circle it, and go to the next barrel, completing the course after circling the third barrel and running home. Barrel racing is a timed event.

The contestant is allowed a running start. At a signal from the starter, the contestant will run to barrel number 1, pass to the left of it, and complete an approximately 360 degree turn around it; then go to barrel number 2, pass to the right of it, and complete a slightly more than 360 degree turn around it; then go to barrel number 3, pass to the right of it, and do another approximately 360 degree turn around it; then sprint to the finish line, passing between barrel number 1 and 2. This barrel course may also be run to the left. For example, the contestants will start to barrel number 2, turning to left around this barrel, then to barrel number 1, turning to the right, then to barrel number 3, turning again to the right, followed by the final sprint to the finish line.

Knocking over a barrel carries a five-second penalty.

Failure to follow the course shall cause disqualification.

A contestant may touch the barrel with his or her hands in barrel racing.

A whip may not exceed two feet in length excluding over and unders which must be attached to the saddle.

It is recommended that drags be conducted before the start of a barrel race and after every seven head. Show management may drag more frequently.

The judge must disqualify any contestant for excessive use of a whip, rope, crop, bat or reins

If a tie occurs where points are involved, placing will be worked off if all tied exhibitors agree to participate in a run-off; if not, a coin toss will be used to separate the ties. The horse declared the winner in the runoff must rerun the pattern within two seconds of its original time or the runoff must be held again. Penalty time will not apply to the two-second rule but will apply to the final runoff time.

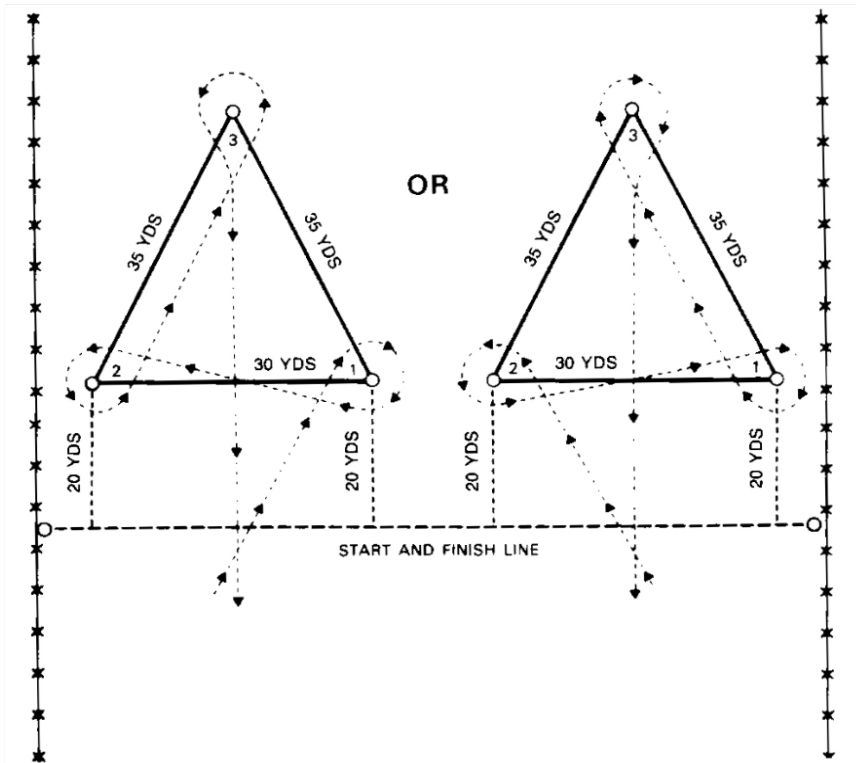

The course must be measured exactly according to diagram and cannot exceed these dimensions. However, if the course is too large for the available space, the pattern should be reduced five yards at a time until the pattern fits the arena. Adequate space must remain between barrels and any obstacle. The distance from barrel number three to the finish line need not be reduced five yards (4.6 meters) at a time if there is sufficient room for the horse to stop.

When measuring the area for the barrel course, allow ample room for horses to complete their turns and stop at the finish. It is recommended there be at least 45 feet (13.5 meters) from the

starting line to the end of the arena, at least 18 feet (5.4 meters) from barrel number 1 and 2 to the fence and 36 feet (10.8 meters) from barrel number 3 to the end of the arena.

Brightly colored 55-gallon (200 liters) steel drums with both ends in must be used. There shall be no rubber or plastic barrels or barrel pads used.

Electronic timers are recommended to be used along with two back-up watches used by official timers. If electronic timer fails, the average of the watches will be used to indicate the official time.

Timing shall begin as soon as the horse's nose reaches the starting line and will be stopped when the horse's nose passes over the finish line.

## **VIOLATIONS**

**VI** No person shall refuse to assist IWHA or its Board of Directors, committees or agents in locating, identifying and inspecting, or to answer promptly and truthfully any inquiry concerning a horse or an ancestor thereof, that has been registered with IWHA, or for which application to register has been made or to promptly and truthfully give information, in form requested, concerning any IWHA matter of which the person has or may have knowledge.

All IWHA representatives shall be treated with courtesy, cooperation and respect, and no person shall direct abusive or threatening conduct or language toward them. No person or entity shall bribe, or attempt to bribe, an IWHA representative, IWHA-approved judge or any other official of an IWHA event.

Any member may be suspended and denied membership and registration privileges and any non-member may be denied privileges by the IWHA Board. The decision of the Board shall be final and the individual must be notified in writing seven days prior to suspension and or termination. A description of disciplinary action may be published on IWHA's official website, *iberianwesternhorseassociation.com*.

A member or nonmember shall not conspire with another person or persons to intentionally violate IWHA rules, or to knowingly contribute or cooperate with another person or persons, either by affirmative action or inaction, to violate IWHA rules.

Ownership of an issued registration certificate remains with IWHA; it is issued in reliance on a written application submitted and attested by the owner and upon the express condition that IWHA has the privilege to correct and/or cancel the certificate for cause under its rules and regulations.

No change or alteration of a registration certificate shall be made except by IWHA or its official representative upon proper showing of the necessity for such change or alteration, by reason of change in color or markings, or mistake; nor shall any person display or advertise, or have in his possession, a certificate that has been changed or altered otherwise than by IWHA or on its authority.

No person or entity shall:

refuse an IWHA request for the return of a registration certificate

issue, sell, exchange, give away or receive, or offer a false or fraudulent certificate, representing the same to be a genuine official certificate issued by IWHA;

represent any horse owned or managed by him/her to be IWHA registered unless the same be registered in the official Registration Book; **V**

represent as a registered Iberian Western Horse any horse other than the horse for which the registration certificate was issued;

hide or attempt to hide the natural markings of a horse by surgery (in addition to the violator being disciplined, horse shall be disqualified);

at any time, apply any substance, including but not limited to any type of colorant, dye, glue or hair to hide or attempt to hide the natural markings of a horse (in addition to the violator being disciplined, horse shall be disqualified);

at any time, apply any substance, including but not limited to any type of colorant, dye, glue or hair to a horse's shoulder, belly, flank or head (in addition to the violator being disciplined

## **V2 INHUMANE TREATMENT.**

No person shall treat any horse in an inhumane manner. This prohibition against inhumane treatment applies to IWHA members and nonmembers. Inhumane treatment shall include, but not be limited to, the prohibited conduct specified below. Inhumane treatment to horses other than Iberian Western Horses and other animals used in competition is included in this prohibition as it indicates a general course of dealing with horses which is unacceptable to IWHA.

For purposes of this rule, a person responsible for the care of a horse is also responsible for and may be disciplined for the inhumane conduct of their trainers, agents, representatives and employees. For violation of this rule, an individual may be disciplined, suspended, fined, denied IWHA privileges, disqualified, expelled from show grounds and/or expelled from IWHA.

Treatment of any horse will be considered inhumane if a person, educated or experienced in accepted equine training techniques, would perceive the conduct of an individual to be

inhumane. Any allegations that prove to have been made maliciously or knowingly to be false will be viewed as a serious disciplinary offense and will be considered a violation of this rule, subjecting the reporting party to penalty by the IWHA.

Inhumane treatment includes, but is not limited to:

placing an object in a horse's mouth so as to cause undue discomfort or distress

a bit in a horse's mouth for extended periods of time so as to cause undue discomfort or distress

tying a horse's head up (above withers), back or around in a stall or anywhere at an IWHA event

tying a horse in a stall without access to food or water for an extended period of time

longeing or riding a horse in a manner as to cause undue discomfort or distress to the horse

tying or fastening any foreign object onto a horse, halter, bridle and/or saddle in order to de-sensitize the horse

use of training techniques or methods such as poling or striking a horse's legs with objects

excessive spurring or whipping

hitting the horse on the head

excessive jerking of reins

excessive fencing

excessive spinning (defined as more than eight (8) consecutive turns in either direction

schooling over ramped oxers in reverse order (i.e., from highest to lowest instead of lowest to highest

schooling using rails higher than four (4) feet

use of prohibited equipment, including, but not limited to: unprotected lip chains saw tooth bits; hock hobbles; tack collars; tack curb straps or tack hackamores; whips used for showmanship; war bridles or like devices; wire or solid metal curb straps no matter how padded; wire cavesson; wire or cable tiedowns; bumper bits; metal bosals (no matter how padded); metal longeing hackamores; chambons; headstalls made of metal (no matter how wrapped or padded), twisted rawhide, or

rope may not be used on a horse's head (3/8 inch rope may be used with a slip/gag bit or a bonnet); running martingales used with curb bits used without rein stops; belly bands; excessively tight cavessons; riding in a curb bit without a curb strap; draw reins attached between or around the front legs will not be allowed; side reins (direct rein from bit to cinch or surcingle); draw rein extensions longer than three (3) inches attached to a bit

use of any item or appliance that restricts the circulation of the horse's tail or use of any item or appliance that restricts movement of the horse's tail use of any drug, chemical, foreign substance, surgical procedure or trauma that would alter a horse's normal tail function

the use of any substance, including but not limited to, any type of colorant, dye, glue or hair to hide an injury created by intentional or negligent treatment, prohibited training techniques or prohibited equipment. For purposes of this rule, "injury" is defined as an open wound, raw area and/or scabbed area

a horse which appears to be sullen, dull, lethargic, emaciated, drawn or overly tired

Intentional or negligent treatment which results in any bleeding, open wound and/or raw area – intentional unintentional for purposes of this section, "negligence" is the failure to exercise care that a reasonably prudent person would exercise. Regardless of whether the bleeding, open wound and/or raw area resulted from intentional or negligent treatment, the horse shall be disqualified;

applying excessive pressure on or excessively jerking of a halter lead shank or lip cord, or an allowed safety lead

it is prohibited to pour any substance into a horse's ears unless it is for a therapeutic purpose, which must be documented in a properly completed Medication Report Form

any other treatment or conduct deemed by a show official to be inhumane or abusive

**V3** IWHA may accept suspension rulings pertaining to cruel or inhumane treatment of horses from other recognized equine related associations and state racing commissions, the effect of which is to automatically suspend the individual from IWHA membership privileges, or deny such privileges, for a length of time equal to the suspension for which reciprocity is given.

**V4 UNSPORTSMANLIKE CONDUCT** or any other form of misconduct that is irresponsible, illegal, indecent, profane, intimidating, threatening or abusive is prohibited. This provision applies to:

IWHA members, nonmembers, exhibitors, trainers, owners, owner representatives, spectators and all other persons on the show grounds of an IWHA event; and

IWHA members on the show grounds of an event held in conjunction with an IWHA-approved event; and

IWHA members on the show grounds of an event during which an IWHA-approved class is held regardless of whether the conduct is associated with or occurs during an IWHA-approved class.

Show management may immediately expel individuals exhibiting unsportsmanlike conduct from show grounds and shall file a written report with IWHA concerning the conduct in question.

#### **V5 INHIBITING COMPETITION.**

Any form of conduct that inhibits competition at an IWHA-approved events is expressly prohibited. This offense includes not only the person suggesting the prohibited conduct, but all who participate in the scheme or plan. Such conduct includes, but is not limited to:

padding classes by entering a horse(s) not otherwise qualified for the competition to fill a class to increase points;

paying another's entry fee, directly or indirectly; or

encouraging a potential competitor to refrain from entering the class.

For inhibiting competition, an IWHA member may be disciplined, suspended, fined and/or expelled from IWHA, and a nonmember may be denied IWHA privileges. Furthermore, violation of this rule shall be grounds for IWHA to disqualify the horse(s) entered by the persons that participate in the scheme or plan prohibited by this rule.

To assist IWHA in the promotion of true competition, any person approached by another to cooperate in a scheme or plan to inhibit competition shall immediately report the matter to show management and then to IWHA in writing within 10 days, failing which, the person approached may be subject to disciplinary action by the Board.

#### **V6 PROHIBITED ASSISTANCE**

If a contestant, while inside the show arena or show ring, is assisted in any manner by another person or provides assistance in any manner to another person, the contestant shall automatically be disqualified. This rule does not apply to cocontestants assisting each other in team events such as cutting. Furthermore, this rule does not apply to a contestant who assists another contestant if such assistance was necessitated for the

safety of competing exhibitors or horses as determined by the judge; however, the contestant in need of such assistance shall be disqualified.

#### **V7 RESPONSIBLE PARTY.**

The exhibitor, Absolutely Responsible Person and owner (collectively referred to as “Responsible Parties”) are each responsible for a horse’s condition, presumed to know all IWHA rules and regulations and are eligible for disciplinary sanctions for violation of IWHA rules and regulations.

An individual is an Absolutely Responsible Person if:

he/she designates himself/herself on the entry blank as exhibitor, or authorizes another to designate him/her as exhibitor on the entry blank;

he/she signs the entry blank on behalf of himself/herself or another, or causes an agent or representative to sign it;

he/she physically participates in the event by riding or showing the horse; or

he/she is the actual trainer, having presented or caused to be presented the horse at the show grounds for exhibition.

Upon request of show management or IWHA representative, every Responsible Party shall:

permit examination of a horse for determination of the presence of prohibited surgery, mechanical device, artificial appliance, foreign drug or substance;

permit examination of a horse for determination of normal tail function; and

permit a specimen of urine, saliva, blood, hair or other substance to be taken for testing.

Refusal to comply with such request shall constitute grounds for immediate disqualification of the horse from further participation at the show, the horse being barred from participation in future IWHA events or shows for such period as determined by the Board or other appropriate committee and suspension of the Responsible Party’s IWHA membership.

#### **V8 PROHIBITED MEDICATION, DRUG OR SUBSTANCE**

The Iberian Western Horse Association will follow the United States Equestrian Federation current year “Guidelines and Rules for Drugs and Medications”. It can be found electronically at *usef.org*.

No person shall cause to be administered internally or externally to a horse, either before or during an approved event, any medication, drug, or substance which could affect its performance or appearance at that event, except for those conditionally permitted therapeutic medications, the use of which is specifically provided for in the guidelines and not otherwise prohibited by governmental regulations.

If the horse has been administered a conditionally permitted therapeutic medication, a medical form, found on the IWHA website, *iberianwesternhorseassociation.com*.

Upon discovery of administration of such prohibited medication, drug or substance, show management shall immediately report the matter to IWHA. Any substance, administered internally or externally, whether drugs or otherwise, or action which may interfere with the testing procedure or mask or screen the presence of a prohibited medication, drug or substance is forbidden.

A sample of urine, blood, saliva and/or hair will be taken at the attending vet's discretion and sent to the laboratory of the vet's choosing. It is presumed the sample of urine, blood, saliva, hair or other substance tested by the approved laboratory is the one taken from the horse in question, its integrity is preserved, and that all procedures of such collection and preservation, transfer to the laboratory, and analysis of the sample are correct and accurate, and the report received from the laboratory pertains to the sample taken from the horse in question and correctly reflects the condition of the horse during the show in which it was entered, with the burden on the exhibitor or other Responsible Party to prove otherwise at any hearing in regard to the matter conducted by IWHA

If the laboratory report on the chemical analysis of urine, blood, saliva or other sample taken from the horse indicates the presence of a prohibited medication, drug or substance, this shall be taken as prima facie evidence such prohibited medication, drug or substance has been administered to the horse either internally or externally.

Presence of a prohibited medication, drug or substance in a horse participating in an IWHA shall be grounds for the Board of Directors to take the following action if it is determined that the use of said medication, drug or substance was not within the guidelines set forth in the Therapeutic Medication Addendum:

disqualify the horse from all classes in which it participates at the show;

bar the horse and exhibitor from participation in further IWHA events or shows for such period as determined appropriate.

**V9 PROHIBITED SURGICAL PROCEDURE, MECHANICAL DEVICE OR ARTIFICIAL APPLIANCE.**

Any surgical procedure, mechanical device or artificial appliance that could affect a horse’s performance or alter its natural conformation or appearance is prohibited unless it meets one of the following exceptions:

surgical procedures performed by a duly licensed veterinarian for the sole purpose of protecting the health of the horse;

use of a pacemaker or prosthetic eye if the owner files a written request for permission and requests it be reviewed and considered by the Board; if granted, will be noted on the horse’s registration certificate;

earplugs or cotton in the horse’s ears.

Upon discovery of the existence of prohibited surgery, mechanical device or artificial appliance, show management shall immediately report the matter to IWHA.

The Responsible Party is eligible for disciplinary actions whether or not they had actual knowledge of the surgical procedure, mechanical device or artificial appliance, or directly authorized the surgical procedure or administration of prohibited devices.

**FEES**

Annual membership	\$30.00
Open/Am(non-pro)/Youth	
Competition license (transfers with horse)	\$25.00
Horse registration	\$50.00
Replacement certificate	\$25.00
Duplicate certificate	\$40.00
Transfer of ownership	\$40.00