



VORTEX™

HIGH PERFORMANCE LUBRICATION



Maintenance-free for lower operating costs

No need for periodic re-greasing or inspection

Dust cap is threaded for easy installation and removal

6 year or 100,000 mile limited warranty



Pregreased with
Lucas Oil Products
Marine Grease



VORTEX™
HIGH PERFORMANCE LUBRICATION

HIGH PERFORMANCE LUBRICATION

VORTEX™ INCLUDES A 6 YEAR/100,000 MILE WARRANTY*. ENGINEERED FOR USE WITH LITHIUM COMPLEX FORTIFIED LUCAS OIL® MARINE GREASE WITH RUST & OXIDATION INHIBITORS. HIGH PRESSURE ADDITIVES ALSO PROVIDE AN ELEVATED DEGREE OF WATER RESISTANCE & WASHOUT PROPERTIES.

* Six year full replacement on hub and bearings

THE DEXTER VORTEX™ LUBRICATION SYSTEM

The hub/spindle is equipped with the Dexter Vortex Lubrication System. Vortex is designed to be maintenance-free. However, there may be an instance when it is necessary to change or add new grease. Bearings can be lubricated without removing the hubs from the axle. Unlike systems that just push new grease on top of old grease, Vortex uses new grease to saturate the inner and outer bearings while pushing out the existing grease. This insures that the hub cavity is completely filled with new grease, if ever required.

SIMPLE SERVICING INSTRUCTIONS

- Remove the threaded grease cap.
- Use a standard grease gun by attaching to the grease fitting located at the end of the spindle confirming the grease gun nozzle is engaged on the fitting tightly.
- Pump grease into the fitting. Grease will flow out of the hub around the spindle.
- Replace screw on cap. When the O-ring and hub meet, turn 1/4 more to secure the cap.
- To maintain the Vortex warranty, Lucas Oil Marine Grease must be used.

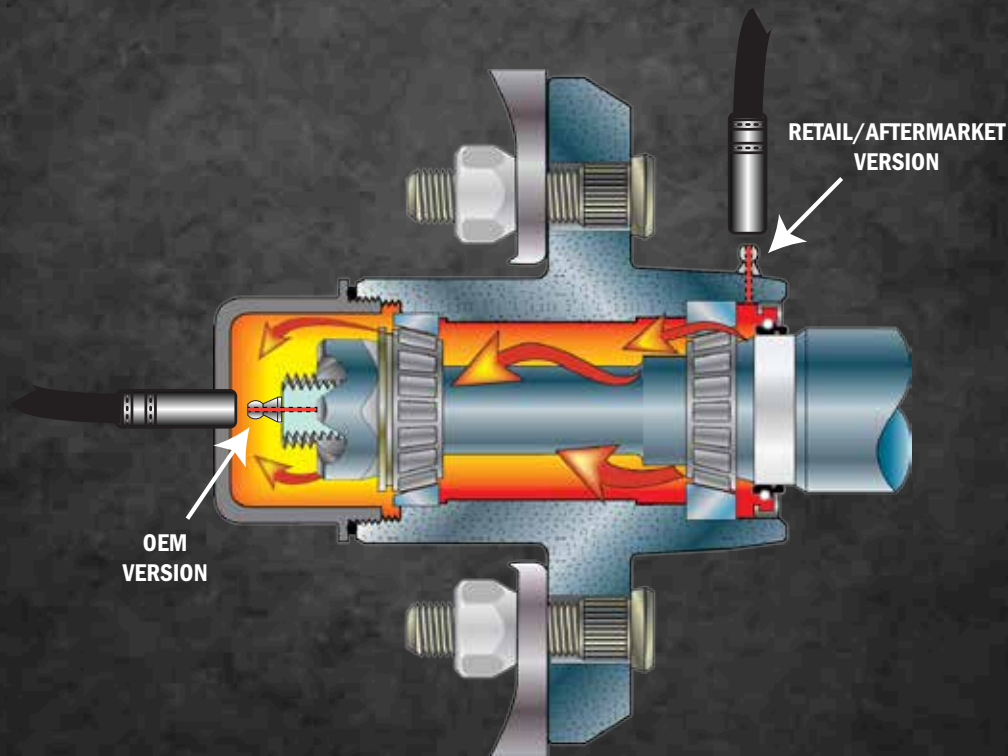

VORTEX™
HIGH PERFORMANCE LUBRICATION



Pregreased with
Lucas Oil Products
Marine Grease

www.dexteraxle.com