

Residential Deck Design Guide

1. The following guide is based upon requirements set forth in the Pennsylvania Uniform Construction Code (PAUCC). Tables and details found in this guide are taken from the International Residential Code (IRC 2015/2018) and the American Wood Council's Deck Building Guide (2015). This guide is intended to provide pertinent and helpful excerpts from the noted sources. Provisions not found in the noted sources are recommended as good industry practice. Where there is a difference between the provisions of this guide and the IRC, the provisions of the IRC shall apply. Alternative construction materials or methods not recognized by the PAUCC shall be evaluated by the ICC Evaluation Service, Inc. or by other accredited agency. **As this is a guide only, contact the authority having jurisdiction for additional requirements or modifications to the following information.**
2. Detailed plans drawn to a suitable scale shall be submitted with the permit application. The plans shall include the following:
 - a. Plot plan showing property lines, easements, size of deck and setbacks from all property lines
 - b. Footing details (footings also required for stairways where they meet grade).
 - c. Size, spacing and length of all posts, joists, and beams shown on a framing plan.
 - d. Stair, handrail and guard details.
 - e. Stair details (riser height = 8¼" max. and tread depth = 9" min). A light source shall be provided at the top landing such that all steps and landings are illuminated.
 - f. Details regarding attachment to the house, joist to beam connections, rail to post connections, and post to footing connections.
 - g. Manufacturer's installation instructions and design details for any/all alternative materials proposed.
3. All lumber shall be pressure treated or naturally resistant to decay. All framing hardware and fasteners (joist hangers, nails, anchors, mechanical fasteners, etc.) shall resist corrosion.
4. Decks supporting uniform live loads exceeding 40 psf, large concentrated loads such as hot tubs, or roofs need to be designed by a licensed engineer.
5. Decks shall not be attached to house overhangs (cantilevers), cantilevered box or bay windows, brick or stone veneers, exterior finishes, or chimneys. These decks would require self-supporting construction methods or a design by a licensed architect or engineer.
6. Decks shall be positively anchored against lateral loads to the primary structure. Tension devices with a design capacity of 1,500 lb. shall be installed in two locations. Tension devices with a design capacity of 750 lb. shall be installed in four locations.
7. Decks for swimming pools must also adhere to the requirements for guards and any other applicable regulations.

DECK TERMS

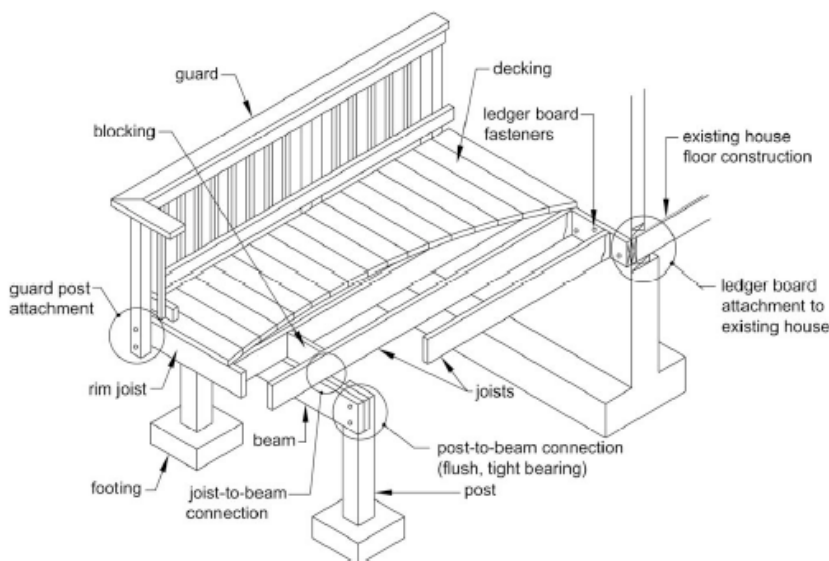

EXAMPLE SITE PLAN



EXAMPLE DECK FRAMING PLANS

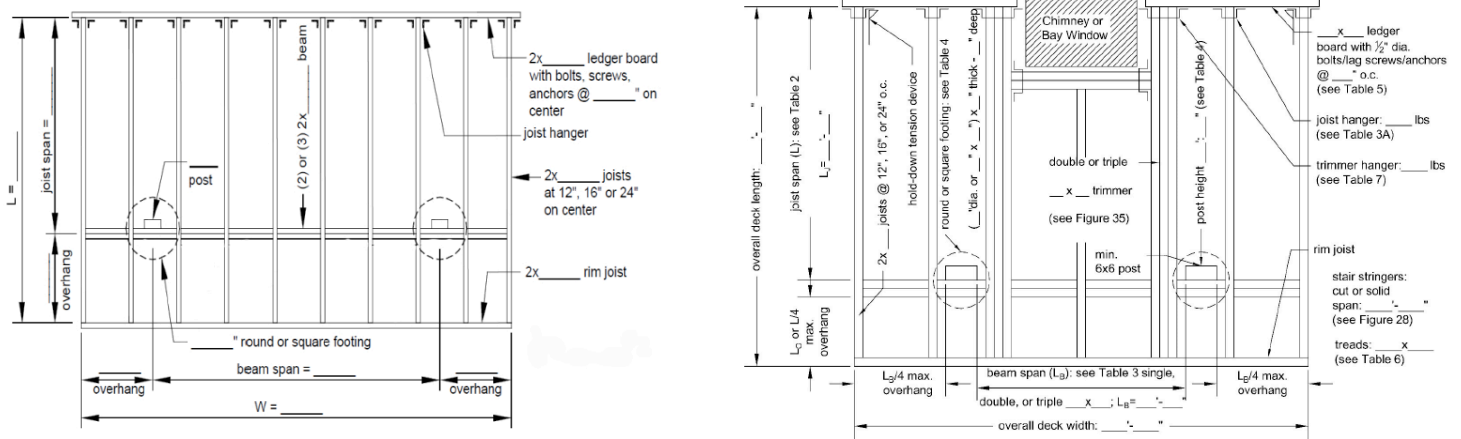

LEDGER REQUIREMENTS

1. The ledger board shall be equal to or greater in depth than the deck floor joists. The existing band joist must be capable of supporting the new deck.
2. Remove exterior finishes prior to installing the ledger board. Install flashings where ledgers are secured to existing construction. Both back flashing (behind ledger) and cap flashing (shingle style flashing over ledger board) are to be provided at deck connections. Flashing shall be installed at a door threshold to prevent water infiltration.
3. Deck ledgers shall not support concentrated loads from beams or girders and shall not be supported on stone or masonry.
4. Attach the ledger board in accordance with one of the typical details below. Fasteners used to connect the ledger board to the band joist and their spacing shall be in accordance with the table and detail below.

TYPICAL DETAILS

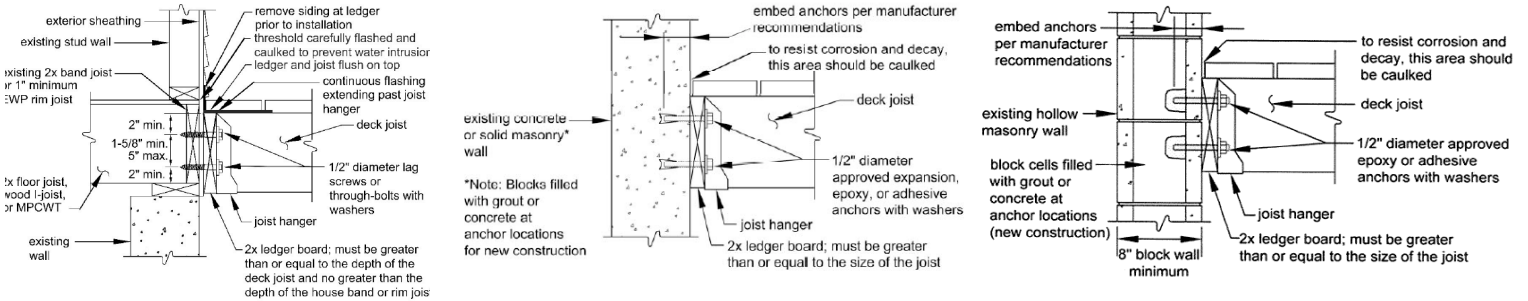

FASTENER REQUIREMENTS

CONNECTION DETAILS	JOIST SPAN						
	6' and less	6'1" to 8'	8'1" to 10'	10'1" to 12'	12'1" to 14'	14'1" to 16'	16'1" to 18'
1/2-inch diameter lag screw with 1/2-inch maximum sheathing ^{a,d}	30	23	18	15	13	11	10
1/2-inch diameter bolt with 1/2-inch maximum sheathing ^d	36	36	34	29	24	21	19
1/2-inch diameter bolt with 1-inch maximum sheathing ^e	36	36	29	24	21	18	16

FASTENER SPACING DETAIL

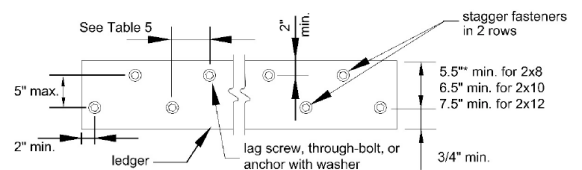

JOIST SIZE AND ASSEMBLY REQUIREMENTS

1. Floor joists shall be sized and installed in accordance with the following details and span table. Joist span is measured between the centerline of bearing at each end of the joist and does not include overhangs.
2. Deck joists are permitted to cantilever not greater than one-fourth of the actual joist span.
3. Floor joist ends and bearing locations shall be provided with lateral restraint. Joist hangers, blocking between joists, or rim joists shall be used for lateral restraint.
4. The ends of each joists shall have a minimum 1 1/2" bearing on wood or metal and not less than 3" on concrete or masonry for the entire width of the joist.
5. A continuous rim joist must be attached to the ends of the deck floor joists as shown in the detail below.

TYPICAL JOIST LAYOUTS

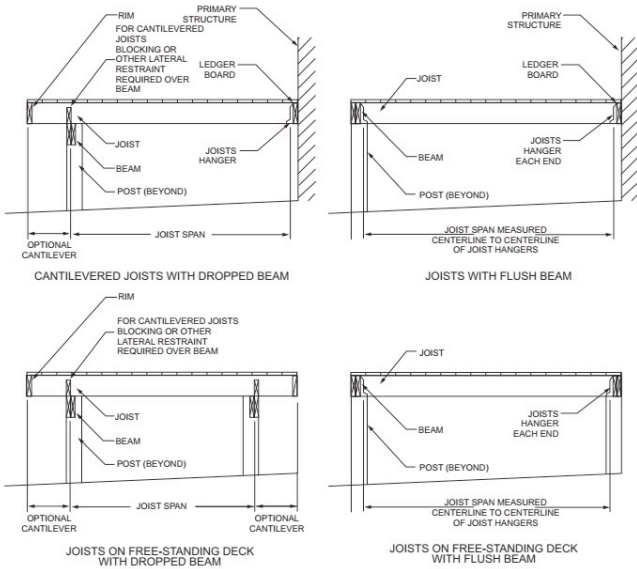

JOIST TO BEAM CONNECTION

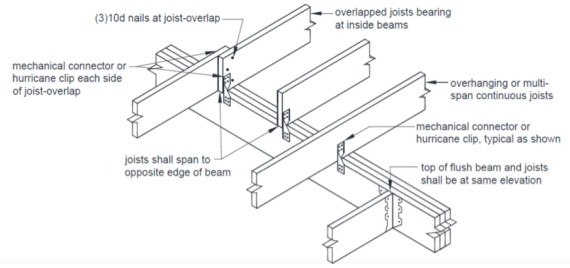

RIM JOIST CONNECTION

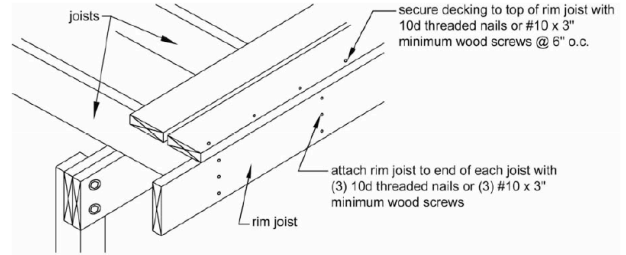

FRAMING AT CHIMNEY OR BAY WINDOW

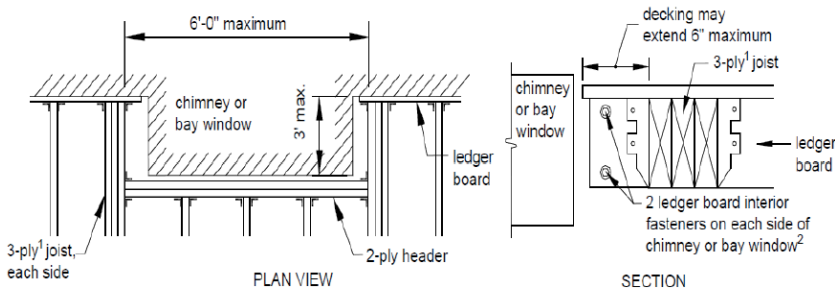

JOIST SPAN TABLE

SPECIES ^a	SIZE	SPACING OF DECK JOISTS WITH NO CANTILEVER ^b			SPACING OF DECK JOISTS WITH CANTILEVERS ^c		
		12	16	24	12	16	24
Southern pine	2 x 6	9-11	9-0	7-7	6-8	6-8	6-8
	2 x 8	13-1	11-10	9-8	10-1	10-1	9-8
	2 x 10	16-2	14-0	11-5	14-6	14-0	11-5
	2 x 12	18-0	16-6	13-6	18-0	16-6	13-6
Douglas fir-larch ^d , hem-fir ^d , spruce-pine-fir ^d	2 x 6	9-6	8-8	7-2	6-3	6-3	6-3
	2 x 8	12-6	11-1	9-1	9-5	9-5	9-1
	2 x 10	15-8	13-7	11-1	13-7	13-7	11-1
	2 x 12	18-0	15-9	12-10	18-0	15-9	12-10
Redwood, western cedars, ponderosa pine ^e , red pine ^e	2 x 6	8-10	8-0	7-0	5-7	5-7	5-7
	2 x 8	11-8	10-7	8-8	8-6	8-6	8-6
	2 x 10	14-11	13-0	10-7	12-3	12-3	10-7
	2 x 12	17-5	15-1	12-4	16-5	15-1	12-4

BEAM SIZE AND ASSEMBLY REQUIREMENTS

1. Beams shall be sized and installed in accordance with the following details and span table. Beam span is measured between the centerline of bearing at each end of the beam and does not include overhangs.
2. Beams are permitted to cantilever at each end up to one-fourth of the actual beam span.
3. Maximum allowable spans for wood beams shall be in accordance with the following details and span table.
4. Splices of multispan beams shall be located at the interior post locations.
5. Beams shall have minimum 1½" of bearing on wood or metal and not less than 3" on concrete or masonry for the entire width of the beam.
6. Deck post to beam connections shall be by either approved post cap or by notching of the post to allow the beam to rest directly on the post.

TYPICAL BEAM ARRANGEMENTS

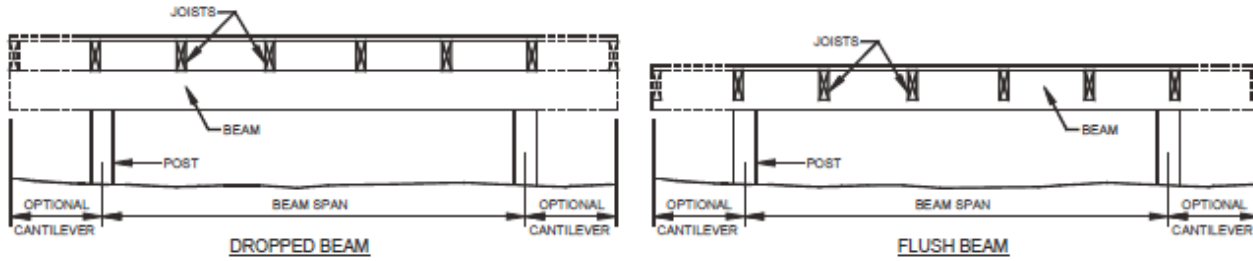

BEAM SPAN TABLE

SPECIES ^a	SIZE ^d	DECK JOIST SPAN LESS THAN OR EQUAL TO: (feet)						
		6	8	10	12	14	16	18
Southern pine	1 - 2 x 6	4-11	4-0	3-7	3-3	3-0	2-10	2-8
	1 - 2 x 8	5-11	5-1	4-7	4-2	2-10	3-7	3-5
	1 - 2 x 10	7-0	6-0	5-5	4-11	4-7	4-3	4-0
	1 - 2 x 12	8-3	7-1	6-4	5-10	5-5	5-0	4-9
	2 - 2 x 6	6-11	5-11	5-4	4-10	4-6	4-3	4-0
	2 - 2 x 8	8-9	7-7	6-9	6-2	5-9	5-4	5-0
	2 - 2 x 10	10-4	9-0	8-0	7-4	6-9	6-4	6-0
	2 - 2 x 12	12-2	10-7	9-5	8-7	8-0	7-6	7-0
	3 - 2 x 6	8-2	7-5	6-8	6-1	5-8	5-3	5-0
	3 - 2 x 8	10-10	9-6	8-6	7-9	7-2	6-8	6-4
	3 - 2 x 10	13-0	11-3	10-0	9-2	8-6	7-11	7-6
3 - 2 x 12	15-3	13-3	11-10	10-9	10-0	9-4	8-10	
Douglas fir-larch ^f , hem-fir ^e , spruce-pine-fir ^e , redwood, western cedars, ponderosa pine ^f , red pine ^f	3 x 6 or 2 - 2 x 6	5-5	4-8	4-2	3-10	3-6	3-1	2-9
	3 x 8 or 2 - 2 x 8	6-10	5-11	5-4	4-10	4-6	4-1	3-8
	3 x 10 or 2 - 2 x 10	8-4	7-3	6-6	5-11	5-6	5-1	4-8
	3 x 12 or 2 - 2 x 12	9-8	8-5	7-6	6-10	6-4	5-11	5-7
	4 x 6	6-5	5-6	4-11	4-6	4-2	3-11	3-8
	4 x 8	8-5	7-3	6-6	5-11	5-6	5-2	4-10
	4 x 10	9-11	8-7	7-8	7-0	6-6	6-1	5-8
	4 x 12	11-5	9-11	8-10	8-1	7-6	7-0	6-7
	3 - 2 x 6	7-4	6-8	6-0	5-6	5-1	4-9	4-6
	3 - 2 x 8	9-8	8-6	7-7	6-11	6-5	6-0	5-8
	3 - 2 x 10	12-0	10-5	9-4	8-6	7-10	7-4	6-11
	3 - 2 x 12	13-11	12-1	10-9	9-10	9-1	8-6	8-1

BEAM ASSEMBLY DETAIL

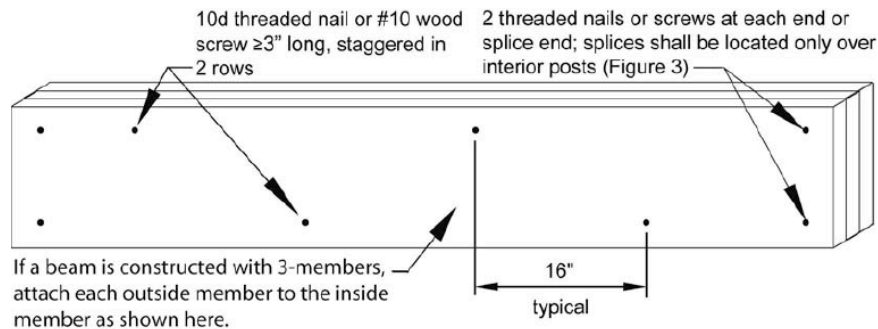

FOOTING REQUIREMENTS

- Concrete for footings shall have a minimum compressive strength of 3,000 psi. All footings shall be a minimum of 36" below grade and bear on undisturbed, natural soil. Deck footings closer than 5'-0" to an existing exterior house wall must bear at the same elevation as the existing footer of the house. **Alternate footing materials/designs will be approved on a case by case basis.**
- Footing size shall be based upon tributary load and an allowable soil bearing capacity of 1,500 psf. (12" diameter minimum). See detail and table below. Footings are required where stairways meet grade.

DETERMINING TRIBUTARY AREA

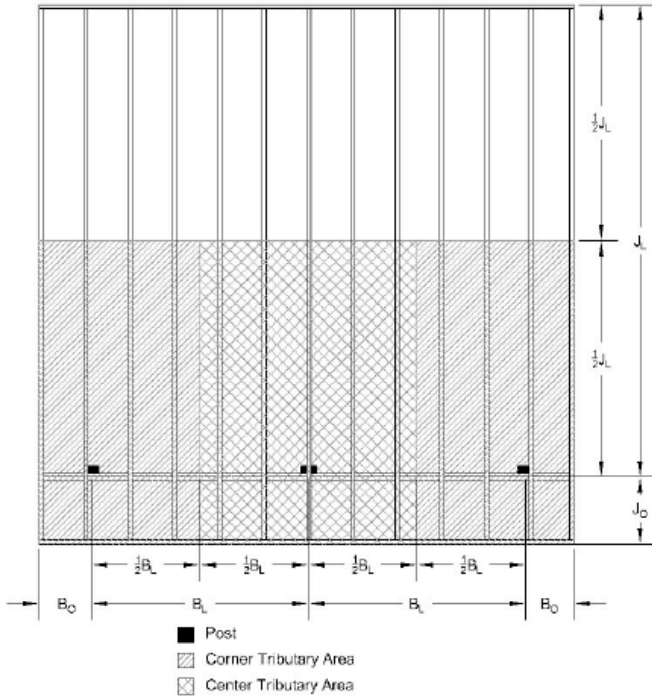

FOOTING TYPES

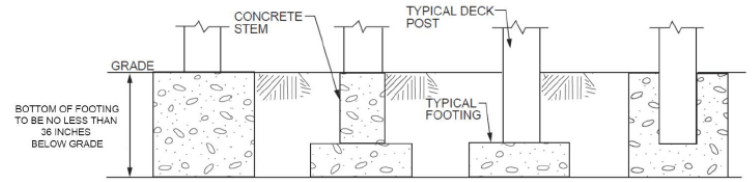

FOOTING REQUIREMENTS FOR STAIRS

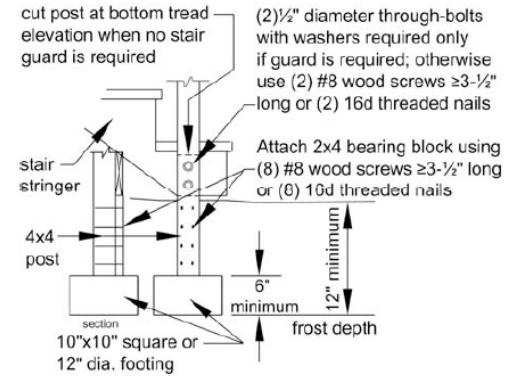

MINIMUM FOOTING SIZES BASED UPON TRIBUTARY AREA

Tributary Area ² (sq. ft.)	Soil Bearing Capacity											
	1500 psf			2000 psf			2500 psf			3000 psf		
	Round Footing Diameter (in.)	Square Footing (in.)	Footing Thickness (in.)	Round Footing Diameter (in.)	Square Footing (in.)	Footing Thickness (in.)	Round Footing Diameter (in.)	Square Footing (in.)	Footing Thickness (in.)	Round Footing Diameter (in.)	Square Footing (in.)	Footing Thickness (in.)
10	8	7	6	7	7	6	7	6	6	6	5	6
20	12	10	6	10	9	6	9	8	6	8	7	6
30	14	13	6	12	11	6	11	10	6	10	9	6
40	16	15	6	14	13	6	13	11	6	12	10	6
50	18	16	7	16	14	6	14	13	6	13	12	6
60	20	18	8	17	15	6	16	14	6	14	13	6
70	22	19	9	19	17	7	17	15	6	15	14	6
80	23	21	9	20	18	8	18	16	7	16	15	6
90	25	22	10	21	19	8	19	17	7	17	15	6
100	26	23	11	23	20	9	20	18	8	18	16	7
110	28	25	12	24	21	10	21	19	8	19	17	7
120	29	26	12	25	22	10	22	19	9	20	18	8
130	30	27	13	26	23	11	23	20	9	21	18	8
140	31	28	13	27	24	11	24	21	10	22	19	9
150	33	29	14	28	25	12	25	22	10	22	20	9
160	34	30	15	29	25	12	25	23	10	23	20	9
170	35	31	15	30	26	13	26	23	11	24	21	10
180	36	32	16	30	27	13	27	24	11	24	22	10
190	37	33	16	31	28	13	28	25	12	25	22	10
200	38	34	17	32	29	14	28	25	12	26	23	11
210	39	35	17	33	29	14	29	26	12	26	23	11
220	40	35	18	34	30	15	30	26	13	27	24	11
230	41	36	18	35	31	15	31	27	13	28	25	12
240	42	37	19	35	31	15	31	28	13	28	25	12
250	43	38	19	36	32	16	32	28	14	29	26	12

- Assumes 40 psf live load, 10 psf dead load, 150 pcf concrete and 2,500 psi compressive strength of concrete. Coordinate footing thickness with post base and anchor requirements.
- Tributary area shall be multiplied by 1.25 at center posts with beams not spliced (continuous).

POST REQUIREMENTS

1. Posts shall be restrained to prevent lateral displacement at the bottom support by use of an approved post base connector.
2. Two-ply beams shall be attached to 4x4 posts with an approved post cap or by notching a 6x6 post. Three-ply beams shall be attached to 6x6 posts with an approved post cap.
3. Diagonal bracing parallel to the beam is required at each corner post greater than 2'-0" in height. Freestanding decks require diagonal bracing both parallel and perpendicular to the beam at each post.

ALLOWABLE POST SIZES

DECK POST SIZE	MAXIMUM HEIGHT*
4 × 4	8'
4 × 6	8'
6 × 6	14'

For SI: 1 foot = 304.8 mm.

a. Measured to the underside of the beam.

BEAM TO POST CONNECTION DETAIL

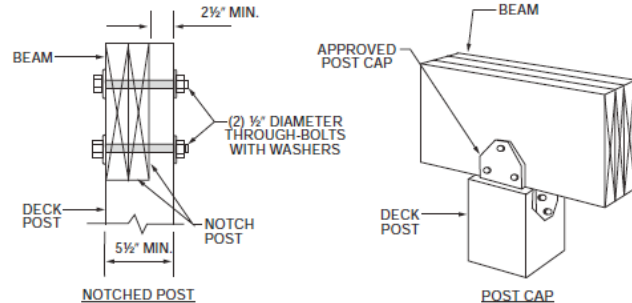

TYPICAL DIAGONAL BRACING

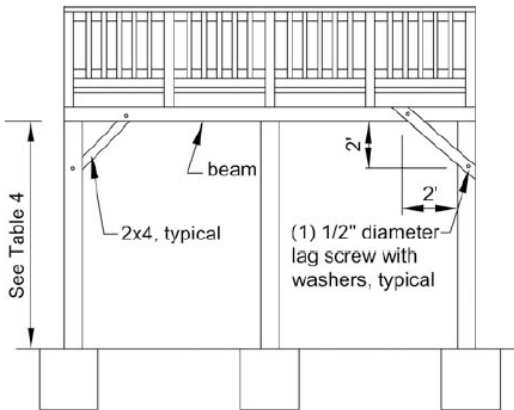

DIAGONAL BRACING PARALLEL TO BEAM

Note: Diagonal Bracing is prohibited on center posts.

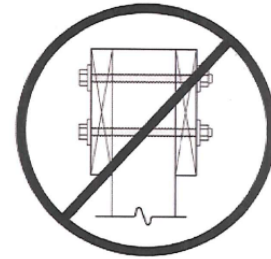

GUARD REQUIREMENTS

1. Guards are required along open sided walking surfaces; including stairs, ramps, and landings that are located 30" vertically above the adjoining floor or grade below at any point within 36" horizontally to the edge of the deck.
2. Guard posts shall be a minimum 4x4 and must be fastened to floor framing members to ensure the entire guard can resist a minimum 200 pound lateral load applied along the top of the guard assembly.
3. Guard posts may be installed on either side of the rim or outside joists. Guard posts shall not be cut or notched.
4. Installed guards shall not be less than 36" high. Guards on the open sides of stairs shall not be less than 34" high.
5. Installed guards shall have opening limitations in accordance with the details below.

GENERAL

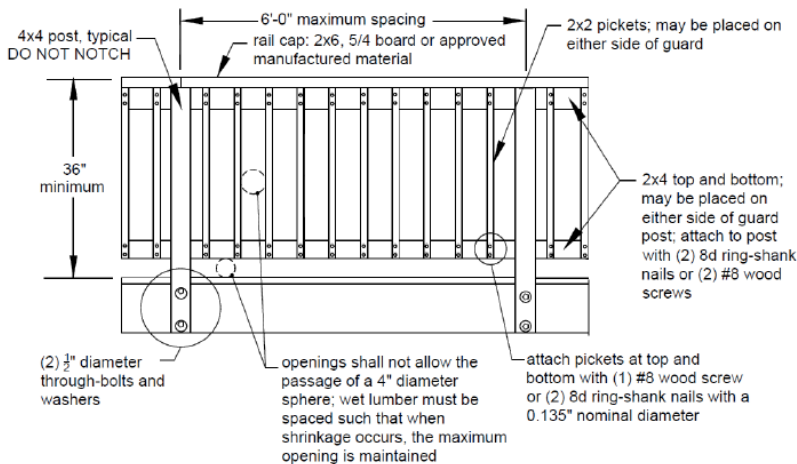

STAIRS

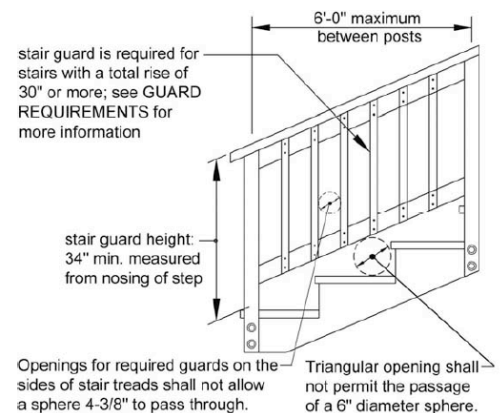

GUARD POST MOUNTED TO EXTERIOR SIDE OF JOIST

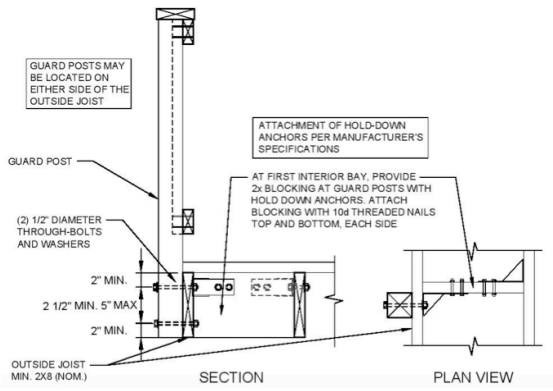

GUARD POST MOUNTED TO EXTERIOR SIDE OF RIM JOIST

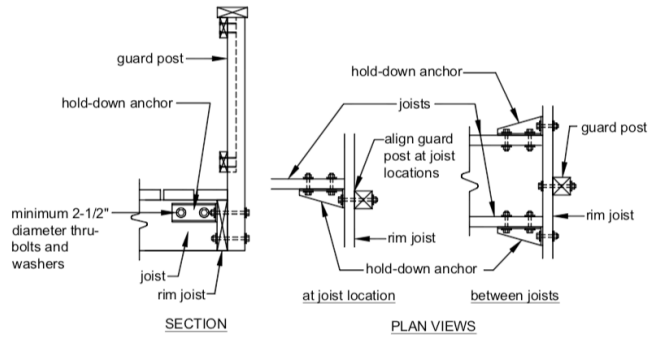

GUARD POST MOUNTED TO INTERIOR SIDE OF RIM JOIST

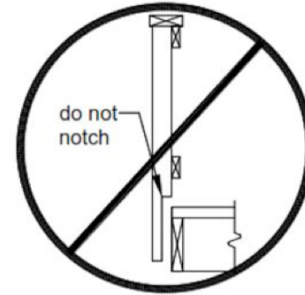
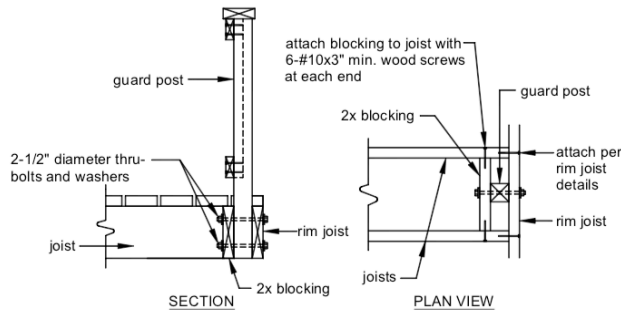

STAIR REQUIREMENTS

1. Stairways shall not be less than 36" in clear width (riser height = 8 1/4" max. and tread depth = 9" min.). Risers may be open but shall not allow the passage of a 4" diameter sphere.
2. All stringers shall be a minimum of 2x12 spaced at a maximum of 18" on center. The maximum span for stringers is shown below. Additional 4x4 posts shall be provided where the span exceeds these dimensions. If the vertical height of the stairway exceeds 12'-0", then an intermediate landing shall be provided.
3. Stairways shall have a light source located at the top landing such that all stairs and landings are illuminated.

STAIR STRINGERS

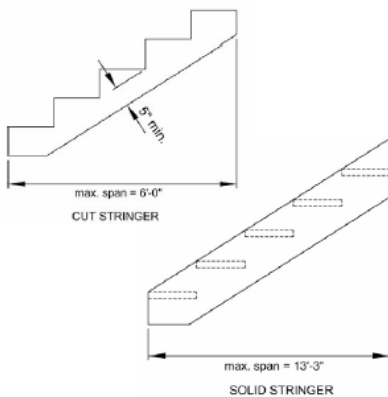

TREAD CONNECTIONS

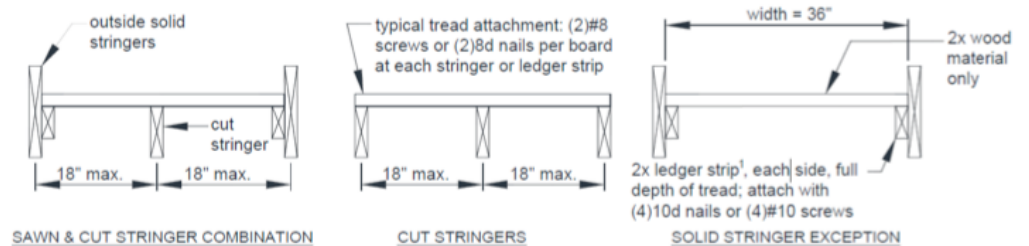

¹ A galvanized staircase clip angle, installed per manufacturer's instructions, is permitted to substitute for the 2x ledger strip.

STAIR STRINGER CONNECTIONS

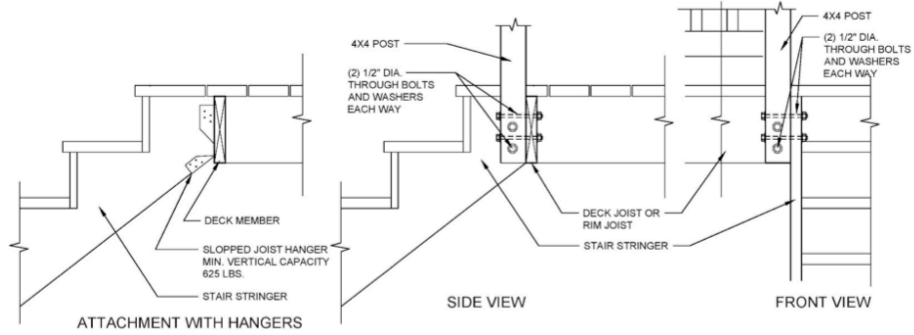

STAIR STRINGER CONNECTIONS AT LANDINGS

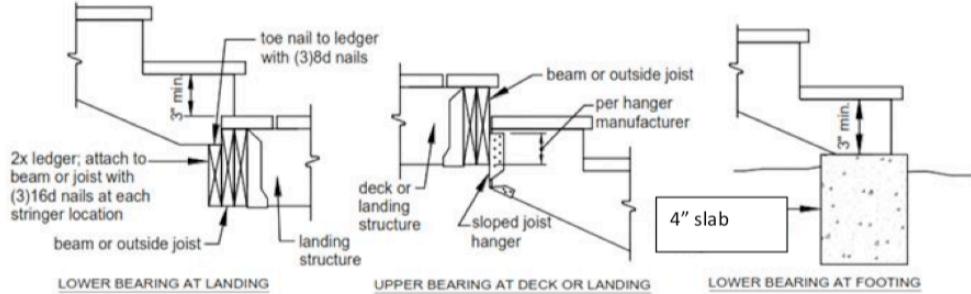

HANDRAIL REQUIREMENTS

1. Handrails shall be provided on at least one side of each run of stairs with four or more risers (height above tread = 34" min. and 38" max.).
2. Handrails shall be continuous for the full length of the stairs.

MISCELLANEOUS REQUIREMENTS

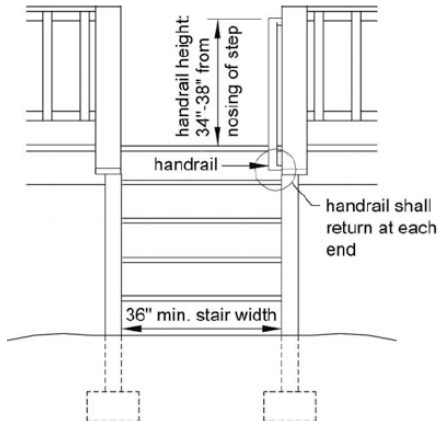

HANDRAIL MOUNTING AND GRIP REQUIREMENTS

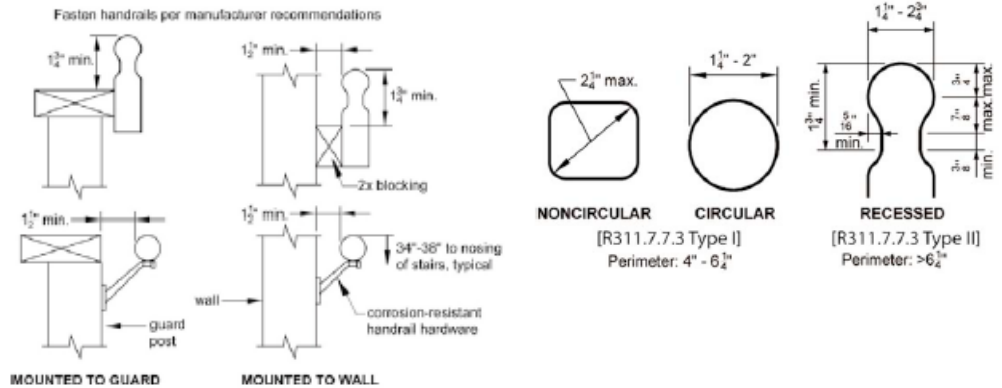

LATERAL LOAD REQUIREMENTS

1. Lateral load connectors shall be installed when the deck is not self-supporting. Connectors shall be installed in compliance with one of the following methods:
 - a. Minimum of two lateral load connectors each with an allowable capacity of not less than 1,500 pounds.
 - b. Minimum of four lateral load connectors each with an allowable capacity of not less than 750 pounds.

1,500 POUND CONNECTOR INSTALLATION

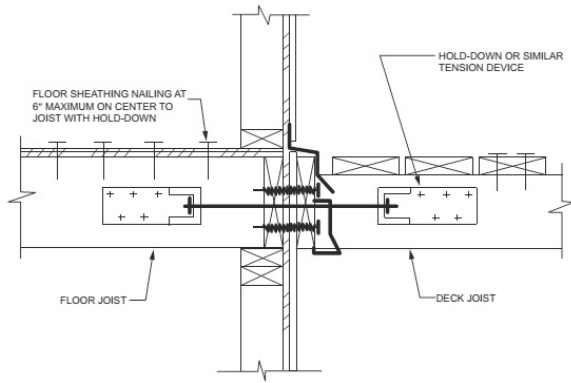

750 POUND CONNECTOR INSTALLATION

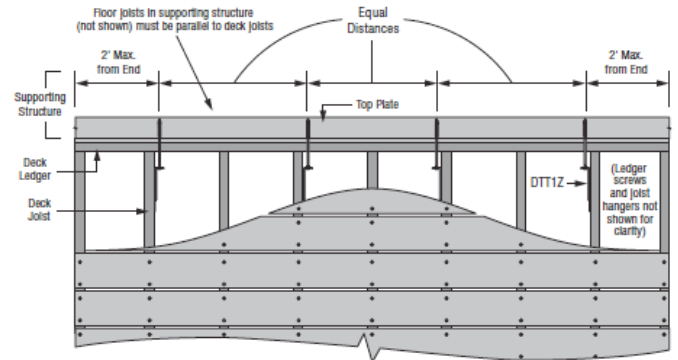
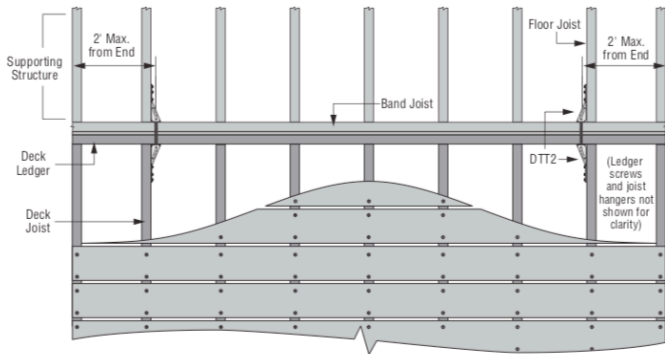
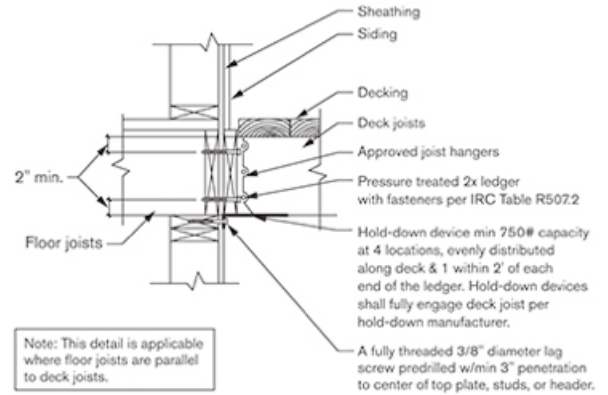

REQUIREMENTS FOR DECKS AT POOLS

1. A 48-inches high guard/gate is required at the base of the stairs that is self-closing and self-latching and equipped to accommodate a locking device.
2. The release mechanism for the latch shall be a minimum of 54-inches from the bottom of the gate or shall be located on the pool side, 3-inches below the top of the gate with no openings greater than 1/2-inch within 18-inches of the release latch.

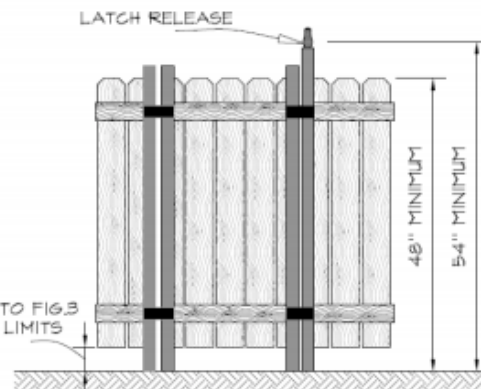
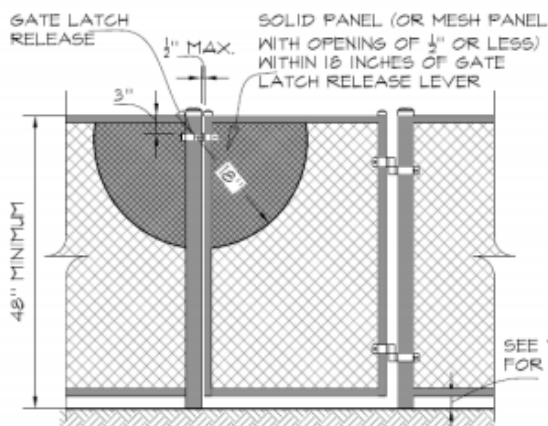
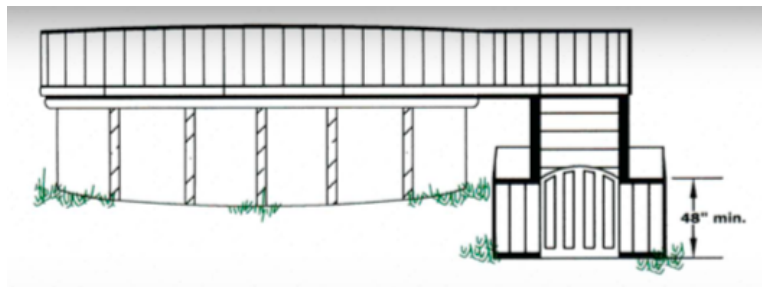

BASE ENGINEERING INC.

CONSULTING ENGINEERS & SURVEYORS

1010 N. QUEBEC STREET, ALLENTOWN, PA 18109-1607

(610) 437-0979
FAX (610) 432-3800

www.BaseEng.com

BaseEngineering@BaseEng.com



CIVIL • STRUCTURAL • MUNICIPAL • ELECTRICAL • MATERIAL HANDLING • MECHANICAL • SUPERVISION

Residential Deck Construction Details

1. The following details are taken from the American Wood Council's Deck Building Guide (2015) and the International Residential Code (IRC 2015/2018). Details not found in the noted sources are recommended as good industry practice. **As this is a guide only, contact the authority having jurisdiction for additional requirements or modifications to the following information.**
2. All lumber shall be pressure treated or naturally resistant to decay. All framing hardware and fasteners (joist hangers, nails, anchors, mechanical fasteners, etc.) shall resist corrosion.
3. Decks supporting uniform live loads exceeding 40 psf, large concentrated loads such as hot tubs, or roofs need to be designed by a licensed engineer.
4. Alternative construction materials or methods not recognized by the PAUCC shall be evaluated by the ICC Evaluation Service, Inc. or by other accredited agency. Manufacturer's installation instructions and evaluation reports shall be submitted for review prior to use.

DECK TERMS

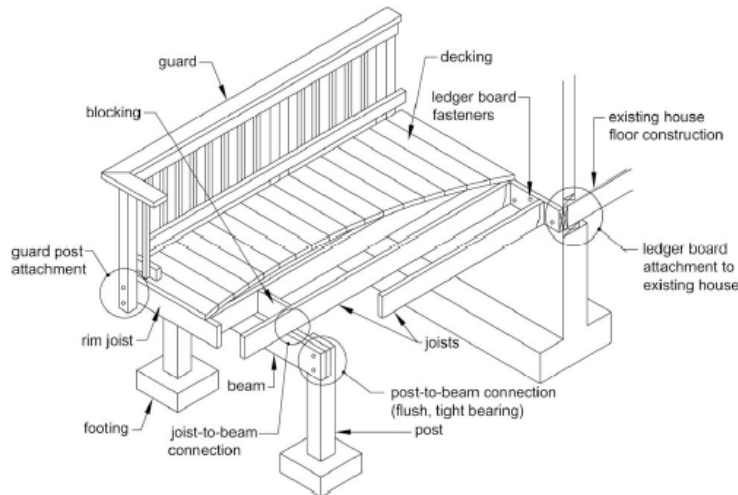

LEDGERS

CONNECTION TO BAND/RIM JOIST

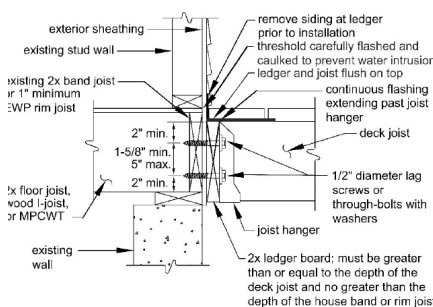

CONNECTION TO CONCRETE/MASONRY WALL

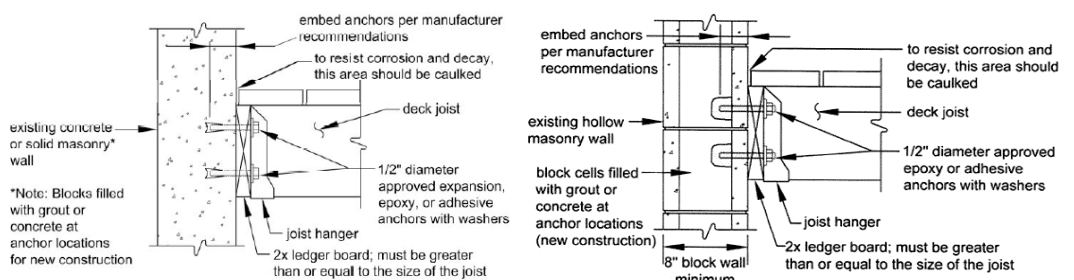

FASTENER SPACING DETAIL

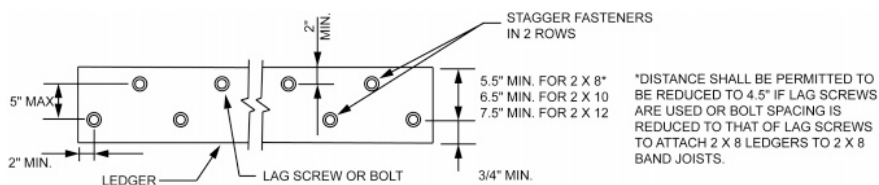

JOISTS

TYPICAL JOIST LAYOUTS

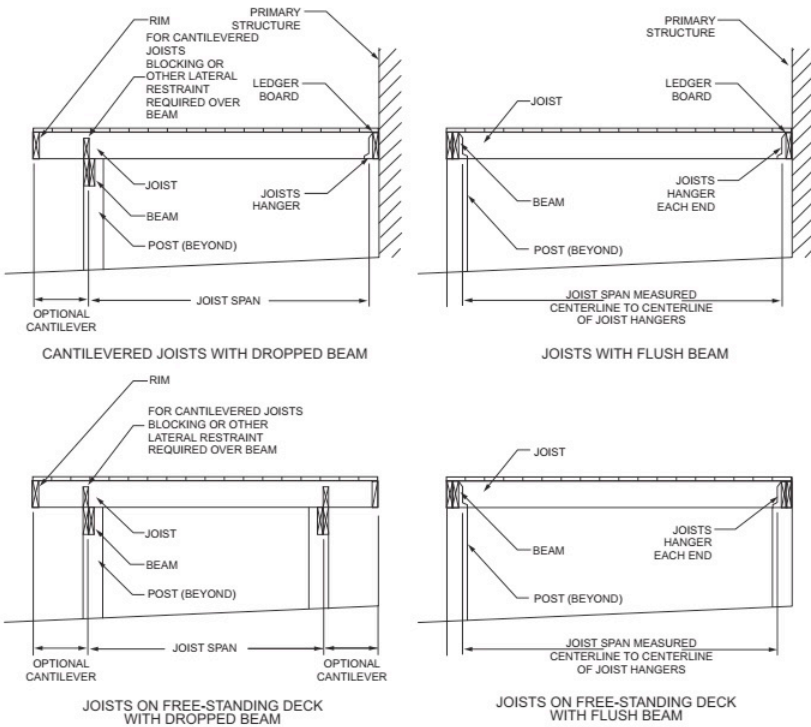

JOIST TO BEAM CONNECTION

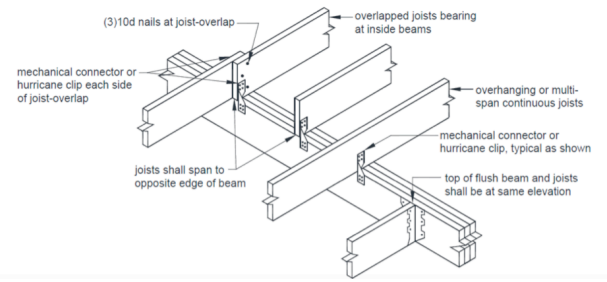

RIM JOIST CONNECTION

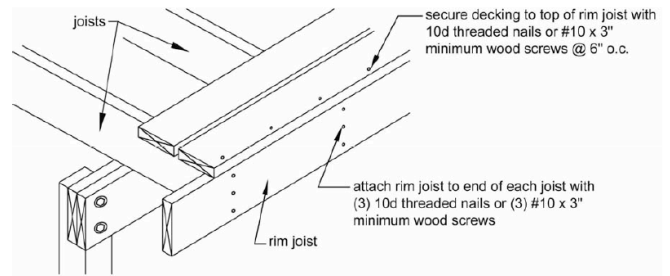

FRAMING AT CHIMNEY OR BAY WINDOW

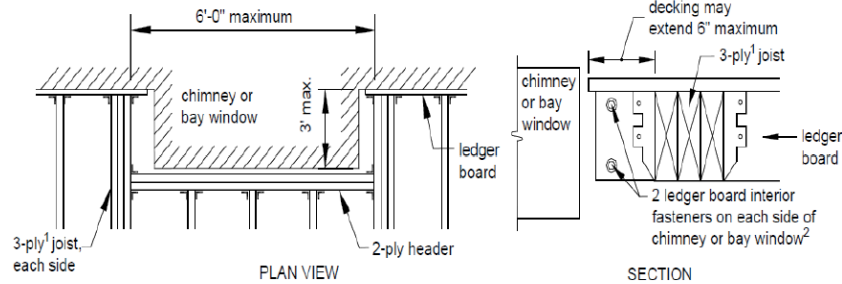

BEAMS

BEAM ASSEMBLY DETAIL

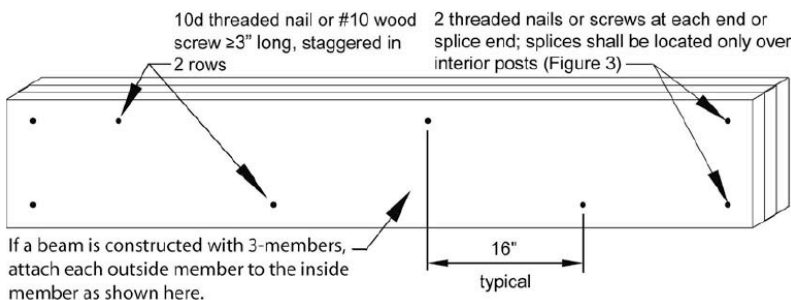

BEAM TO POST CONNECTION DETAIL

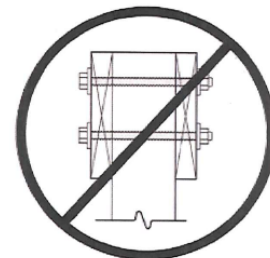

BEAM TO POST CONNECTION DETAILS

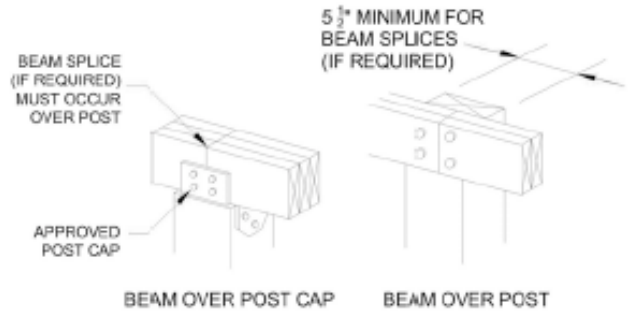
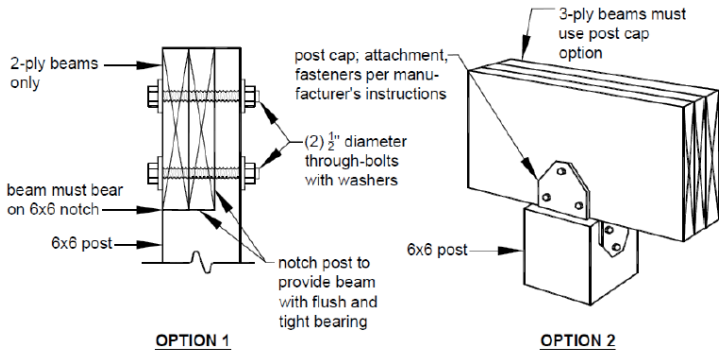

GUARDS

GENERAL

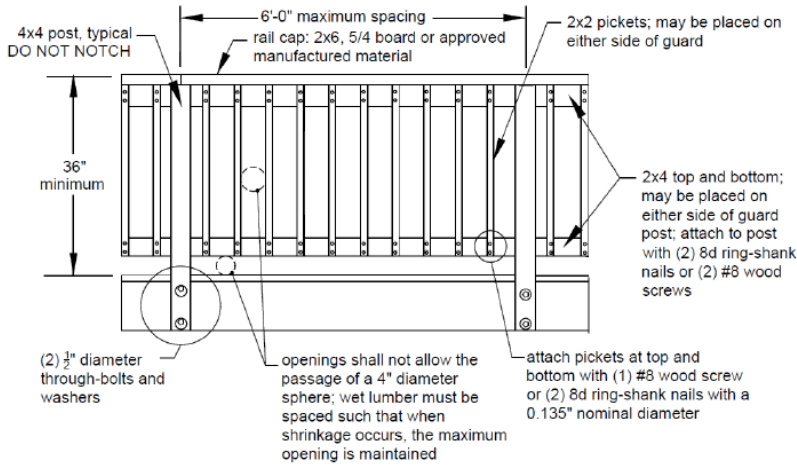

STAIRS

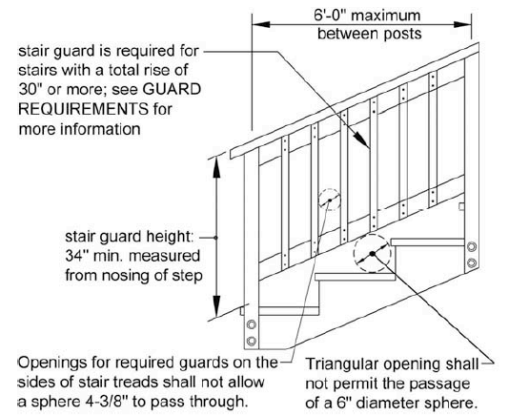

GUARD POST MOUNTED TO EXTERIOR SIDE OF JOIST

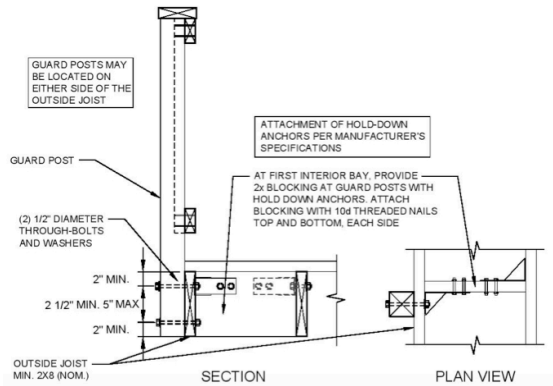

GUARD POST MOUNTED TO EXTERIOR SIDE OF RIM JOIST

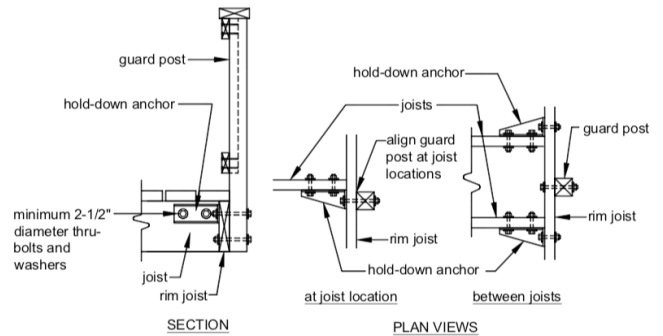

GUARD POST MOUNTED TO INTERIOR SIDE OF RIM JOIST

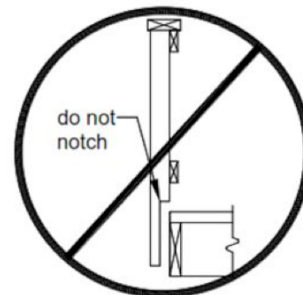
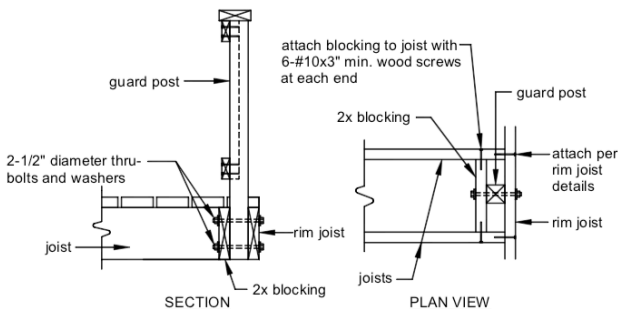

STAIRS

STAIR STRINGERS

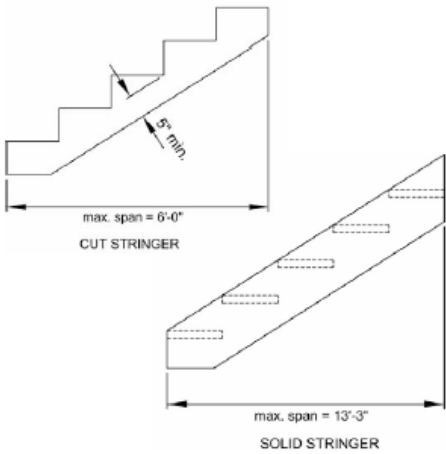

TREAD CONNECTIONS

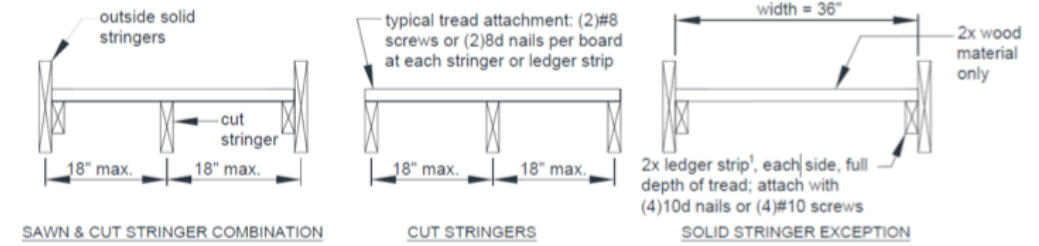

¹ A galvanized staircase clip angle, installed per manufacturer's instructions, is permitted to substitute for the 2x ledger strip.

STAIR STRINGER CONNECTIONS

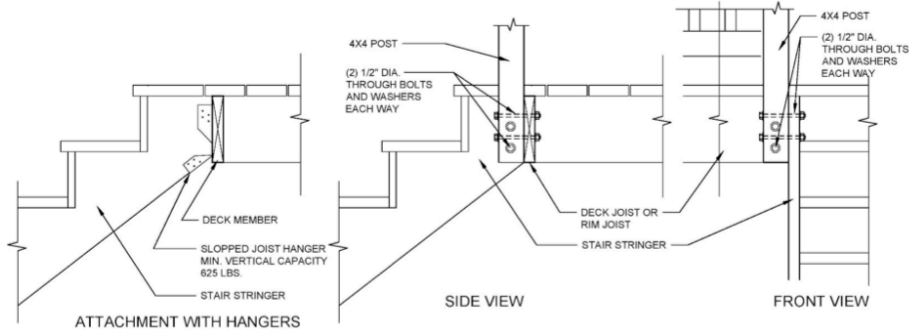

STAIR STRINGER CONNECTIONS AT LANDINGS

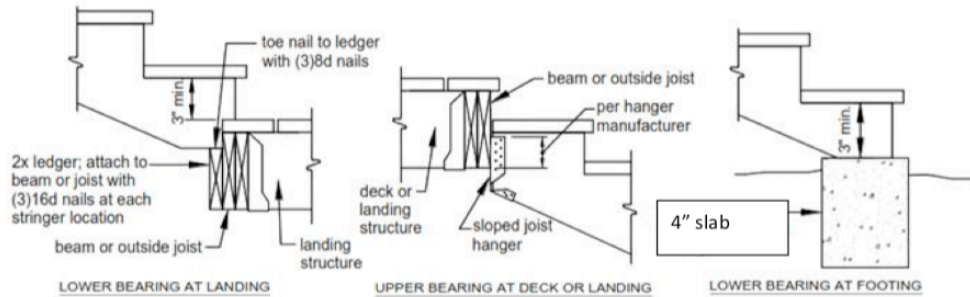

HANDRAILS

HANDRAIL MOUNTING AND GRIP REQUIREMENTS

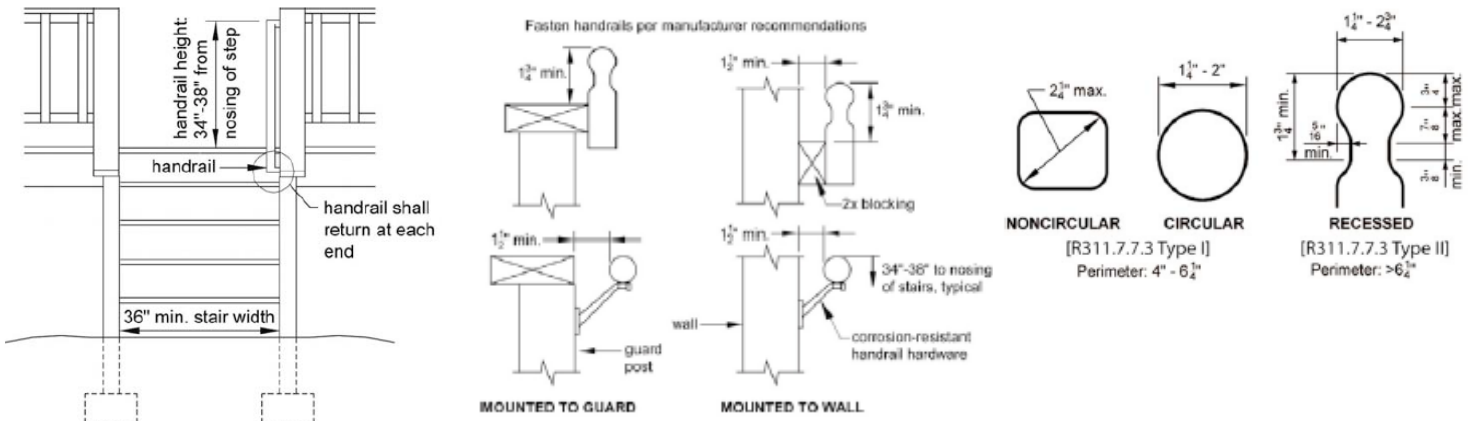

LATERAL LOAD REQUIREMENTS

1,500 POUND CONNECTOR INSTALLATION

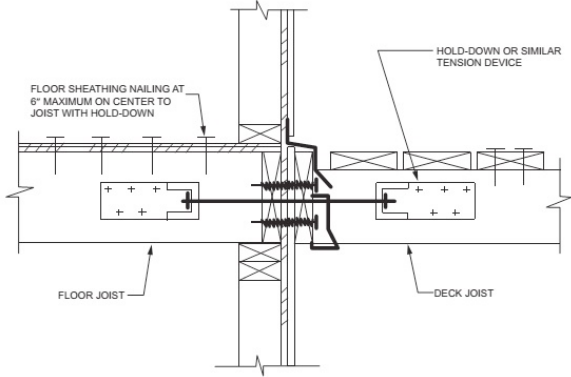

750 POUND CONNECTOR INSTALLATION

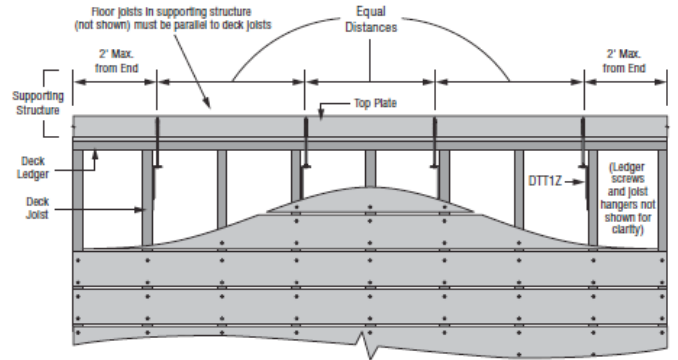
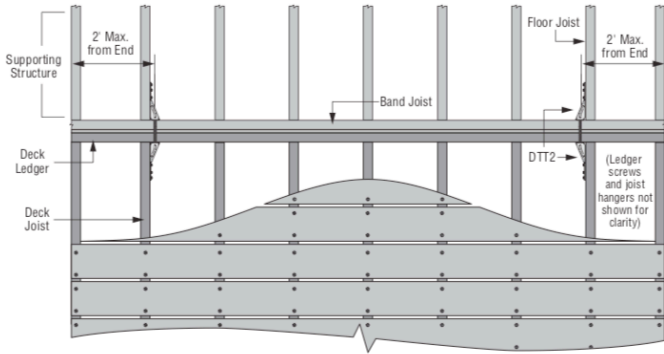
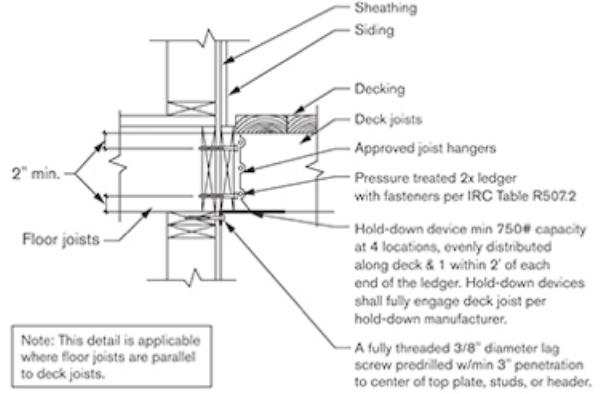



Residential Deck Framing Plan

