

## Specifications and Options

# Exhaust only Canopy Type Kitchen Hood – Model EH

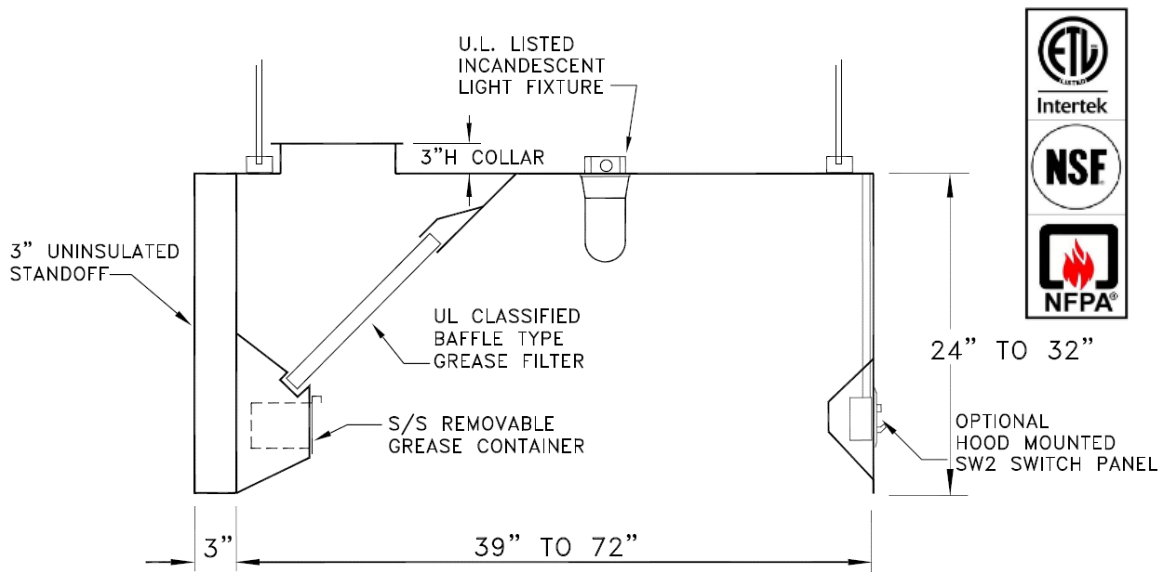

### Hood Specifications:

- **Material:** Exposed hood areas constructed of 18 gauge type 304 stainless steel or 430 stainless steel with # 3 polish. Unexposed areas constructed of 18 gauge aluminized steel.
- **Construction:** Exterior shell of hood is continuously welded liquid tight per NFPA-96. All exposed joints and seams are polished to the original finish. Hood front is double shell construction for added hood front rigidity at all hood lengths.
- **3" Rear Standoff:** Non-insulated, factory installed at rear of hood provides 3" clearance to rear wall.
- **Lights:** U.L. Listed Incandescent type light fixtures located on 3' to 4' centers. Lights include shatterproof globes. Lights are pre-wired to junction box at top of hood.
- **Filters:** U.L. Classified heavy duty aluminum or stainless steel baffle type grease filters located in hood filter frame assembly. Filters are removable for cleaning.
- **Grease Container:** Concealed stainless steel removable grease container located in hood interior isolated from airstream.

### Hood Options:

- **Material:** Entire hood constructed of 18 gauge or 16 gauge stainless steel or aluminized steel.
- **Lights:** U.L. Listed Recessed fluorescent type or LED light fixtures available, double tube style in 3' or 4' lengths.
- **Filters:** U.L. Classified heavy duty stainless steel baffle type grease filters.
- **Grease Extractors:** All stainless steel construction high velocity grease extractor for up to 95% grease containment.
- **Switch Panel:** Hood mounted or provide loose for wall mounting. Panel may contain various light and fan switch combinations as required for system operation.
- **3" Standoff:** Insulated or Non-insulated, factory installed at hood ends or top as required for clearance to combustible or limited combustible surfaces.

## Specifications and Options

# Exhaust only Canopy Type Kitchen Hood – Model EH

### Hood Specifications:

- **Material:** Exposed hood areas constructed of 18 gauge type 304 stainless steel or 430 stainless steel with # 3 polish. Unexposed areas constructed of 18 gauge aluminized steel.
- **Construction:** Exterior shell of hood is continuously welded liquid tight per NFPA-96. All exposed joints and seams are polished to the original finish. Hood front is double shell construction for added hood front rigidity at all hood lengths.
- **3" Rear Standoff:** Non-insulated, factory installed at rear of hood provides 3" clearance to rear wall.
- **Hanger Brackets:** Heavy steel 6" uni-strut hanger brackets at hood top with adjustable spring loaded rod coupling for 1/2" threaded hanger rod.
- **Exhaust Duct Collar:** 3" High Exhaust duct collar is factory installed in top of hood or shipped loose for field location. Duct collar contains perimeter welding flange for field welding of exhaust duct.
- **Approvals:** Hood is ETL Listed to conform to U.L. 710 standards. Hood is NSF Listed and built in strict accordance with the latest edition of National Fire Protection Association, NFPA-96

### Hood Options:

- **Material:** Entire hood constructed of 18 gauge or 16 gauge stainless steel or aluminized steel.
- **Lights:** U.L. Listed Recessed fluorescent type or LED light fixtures available, double tube style in 3' or 4' lengths.
- **Filters:** U.L. Classified heavy duty stainless steel baffle type grease filters.
- **Grease Extractors:** All stainless steel construction high velocity grease extractor for up to 95% grease containment.
- **Ceiling Closure Panels:** Closure panels to close off space between top of hood and ceiling as required can be factory installed to hood top or provided loose for field installation. -Side Skirts: Left or Right end skirt to close off end of hood as required.
- **Wall Panels:** S/S construction wall panels provided loose for field installation behind hood.
- **Fire Control Cabinet:** Fabricated onto left or right end of hood to contain fire system controls and electrical controls as required.
- **Zero Clearance:** Using approved methods of insulating a hood for Zero Clearance to combustibles for the front, top, and sides of the hood.
- **Side Skirts:** Left or Right end skirt to close off end of hood as required.

## Specifications and Options

# Exhaust only Canopy Type Kitchen Hood – Model EH

Exhaust Hood for Commercial Cooking Appliances, Listed by ETL, for Compliance with UL710 Standard for Safety “Exhaust Hoods for Commercial Cooking Equipment”

Suitable for Use with Cooking Appliances Developing Surface Temperatures up to 700 Degrees F.

18” Clearance to Combustibles Required

38”	<i>Minimum Space (IN.) Between Front Lower Edge of Hood and Cooking Surface</i>
44”	<i>Maximum Space (IN.) Between Front Lower Edge of Hood and Cooking Surface</i>
155	<i>Minimum Exhaust Airflow (CFM) (The rated exhaust airflow rates were established under controlled laboratory conditions and greater exhaust airflow may be required for complete vapor and smoke removal in specific installations.)</i>
6”	<i>Minimum Front Overhang of Cooking Surface (IN.)</i>
6”	<i>Minimum Front Setback of Cooking Surface (IN.)</i>
12”	<i>Minimum Side Overhang of Cooking Surface (IN.)</i>
4’	<i>Minimum Hood Length</i>
16’	<i>Maximum Hood Length with Single Collar</i>

## CFM Information Data – Wall Mounted Application –Model EH

<b>Cooking Equipment</b>	<b>Average Surface Cooking Temp. Degrees F.</b>	<b>Exhaust CFM Per Foot of Hood Length</b>	<b>Supply CFM - Hood (% of Exhaust)</b>	<b>Supply CFM Introduced Into Kitchen Area</b>
<b>Light Cooking Load –</b> <i>Ovens, Kettles, Ranges, Steam Equipment, Rotisseries</i>	250 to 400 Degrees F	155	N/A	Up to 100%
<b>Medium Cooking Load-</b> <i>Griddles, Fryers, Braising Pans, Skillets, Salamanders, Upright Broilers</i>	400 Degrees F.	200	N/A	Up to 100%
<b>Heavy Cooking Load-</b> <i>Electric or Gas Char-broilers, Wok Ranges</i>	700 Degrees F.	275	N/A	Up to 100%