

**DGS 66**

# Installation Manual

SEED TO SUPER FEED IN ONLY 6 DAYS

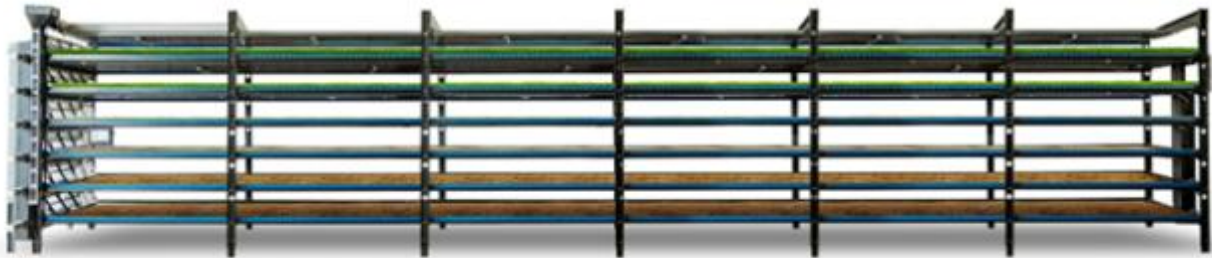

## Main Office

47168 Haylie St.  
Sioux Falls, SD 57107  
United States

Email: [HGinfo@hydrogreenglobal.com](mailto:HGinfo@hydrogreenglobal.com)

Phone: +1 605-277-7271

## Overview

This manual contains the information that will allow you to assemble and install your HydroGreen Grow System.

Your safety and the safety of those around you is important. Installing HydroGreen Grow Systems safely is an important responsibility.

You must also use your own good judgement as it is not possible to warn you about all the hazards associated with assembling, installing, and maintaining commercial equipment.

## Notes

- This manual commonly refers to the 4 sides of a DGS 66 as **front**, **rear**, **high side**, and **low side**.
- HydroGreen Grow Systems harvest and seed at the **front** of the machine.
- The machine levels slope toward the **low side** of the machine according to the site plan.

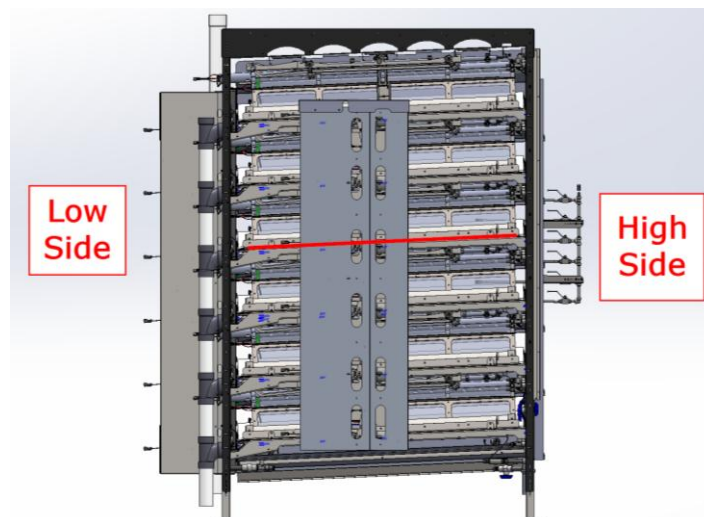
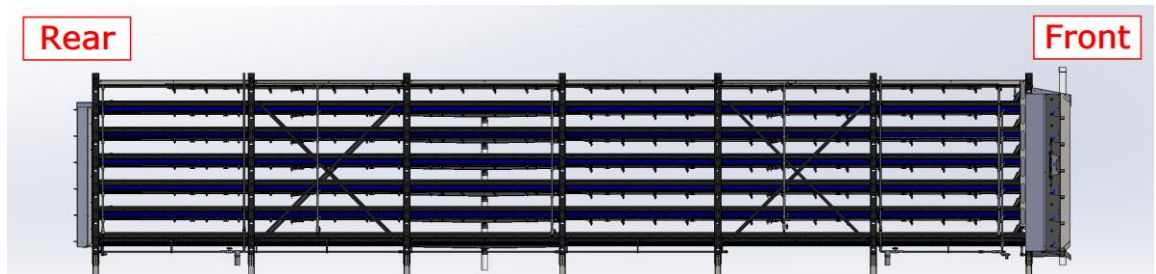

# Contents

---

Contents .....	3
1. Chalking Location .....	5
2. H-Frame Assembly .....	6
3. Connecting H-frames .....	9
4. Table Leveling .....	13
5. Belt Position Switches & Pans .....	16
6. Assembly Spray Booms .....	18
7. Spray Booms & Lighting .....	19
8. High Side Plate & Drippers Installation .....	23
9. Water Manifolds .....	28
10. Install the Grain Disinfectant Boom .....	30
11. Install Spray Boom Hoses .....	33
12. Seeder Assembly & Installation .....	35
13. Drain Pans .....	42
14. Unload Chute & Drive Shaft Assembly .....	45
15. Harvest Motor & Jaw Clutch .....	50
16. Hydraulic Sizer .....	53
17. Pull Back Assembly Installation .....	54
18. Belts .....	58
19. Spray Boom Drive Assembly .....	60
20. Hydraulic Sizer Manifold .....	62
21. Front Nodes & Air Solenoids .....	63
22. Front Air Line .....	64
23. E-Stop .....	66
24. Rear Nodes & Air Solenoids .....	67
25. Rear Air Lines .....	69
26. General Wiring Diagram .....	70
27. Front Node Harnesses .....	71
28. Rear Node Harnesses .....	76
29. Middle Node (1) .....	82
30. Middle Node Harness .....	83
31. Install the screen case assembly. ....	86
32. Power Supply Box. ....	87

33. Junction Box .....	88
34. Water Mainline.....	90
35. Guards & Drains .....	95
36. Kits & Pallets .....	101

# 1. Chalking Location

## 1.1. Chalk the location of the frame on the floor.

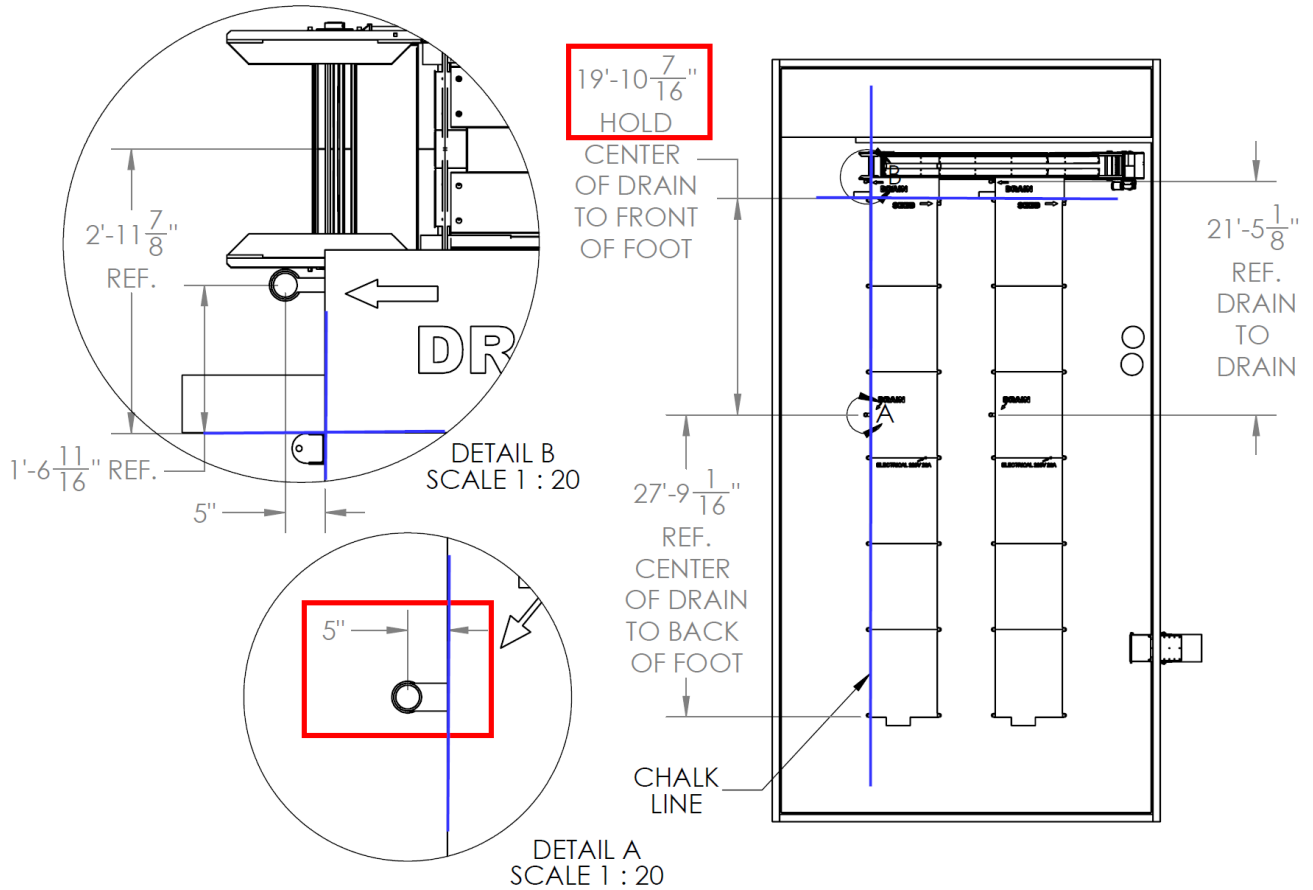

## 2. H-Frame Assembly

Qty	Part #	Description	Pallet
1	30-0106	Kit, Hardware, DGS 66	1
42	51-1906	Cross Brace	3
7	51-1911	Top Support	3
14	51-1912	Foot	9
14	51-2180	Leg	2

- 2.1. Locate and arrange the parts above on sheets of cardboard as shown below.
- 2.2. Orientate the drain side to the center of the room or closest to the floor drains.

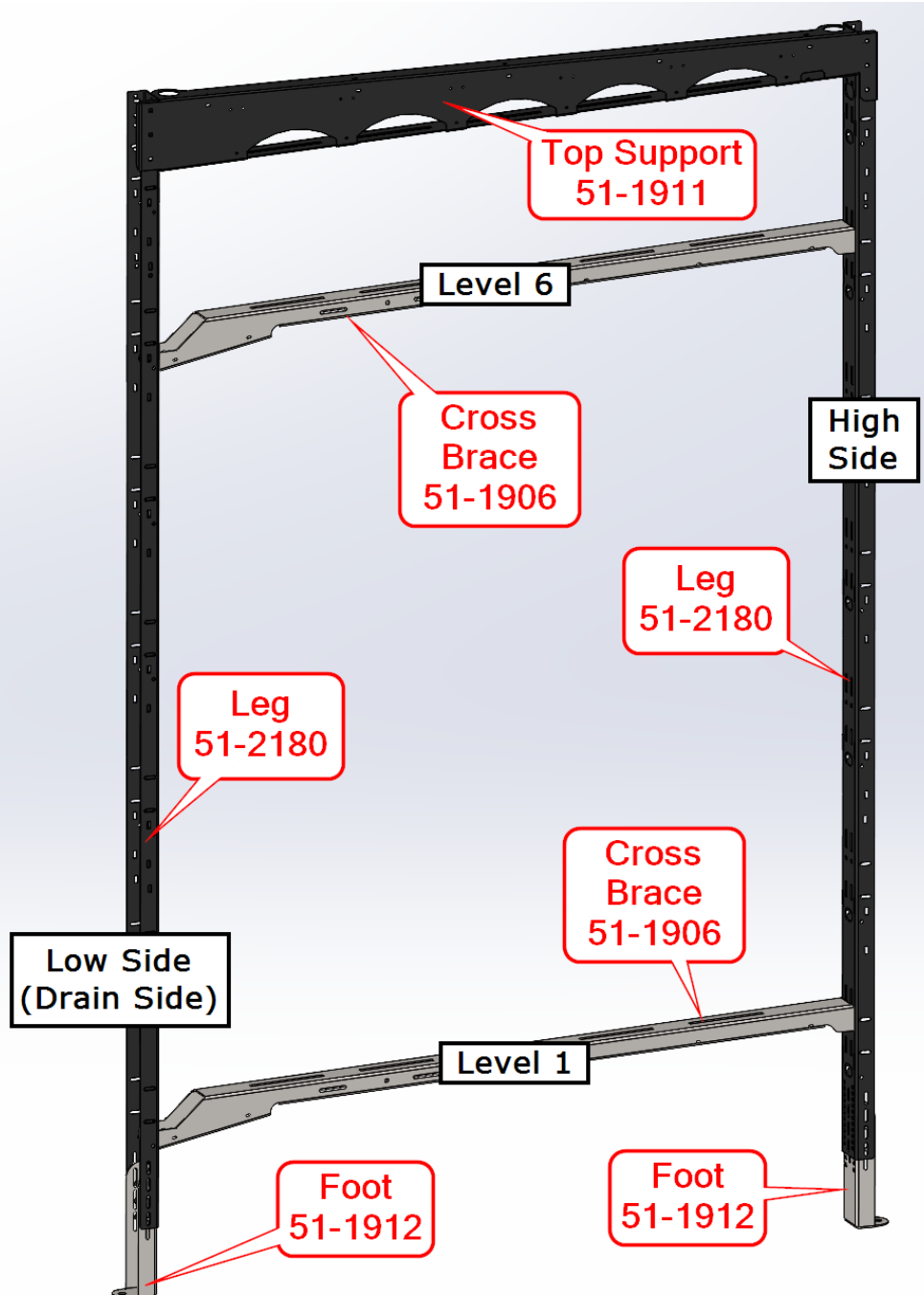

**2.3. Attach both feet to the legs with two 5/16" x 3/4" carriage head bolts with flange nuts, finger-tighten.**

**Note:** This step can be completed on a set of sawhorses or table.

**Note:** You will level the machine in Section 4 of this manual, so choose a hole near the middle for now.

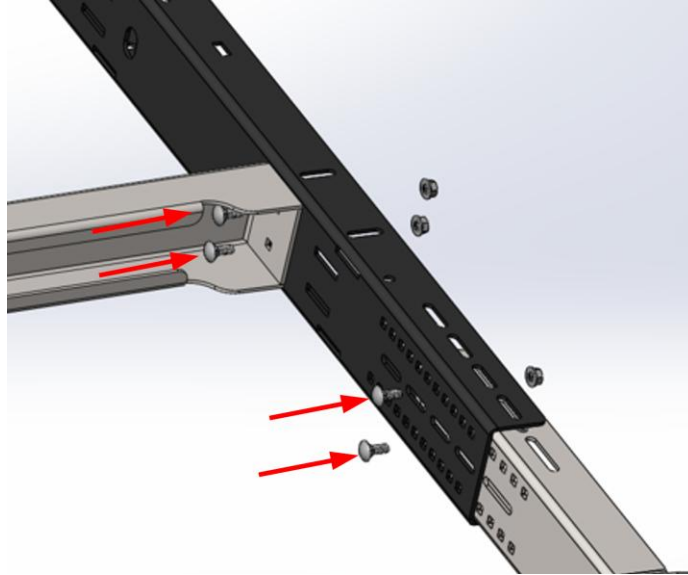

**2.4. Attach a top support to each leg upper with three 5/16" carriage head bolts and flange nuts finger tight.**

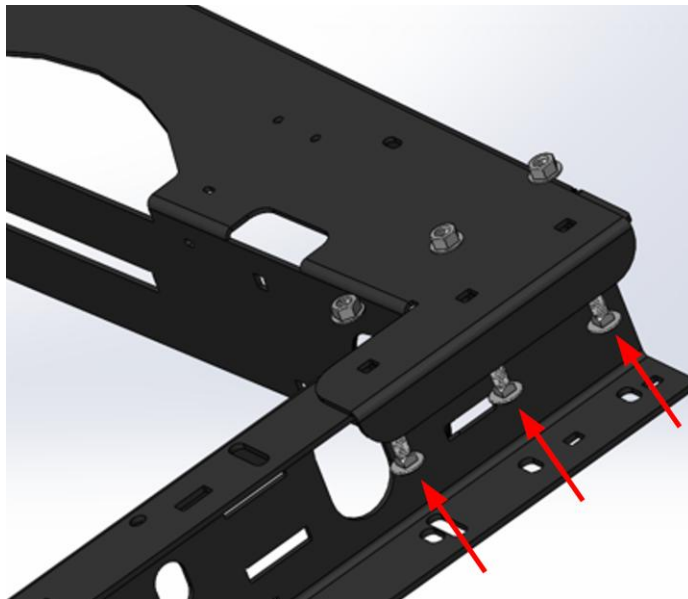

2.5. Place the tabs of the cross braces into the legs of levels 1 & 6. Tap into place with a rubber mallet.

2.6. Fasten with a 1/4" x 4-1/2" bolt with flange nut.

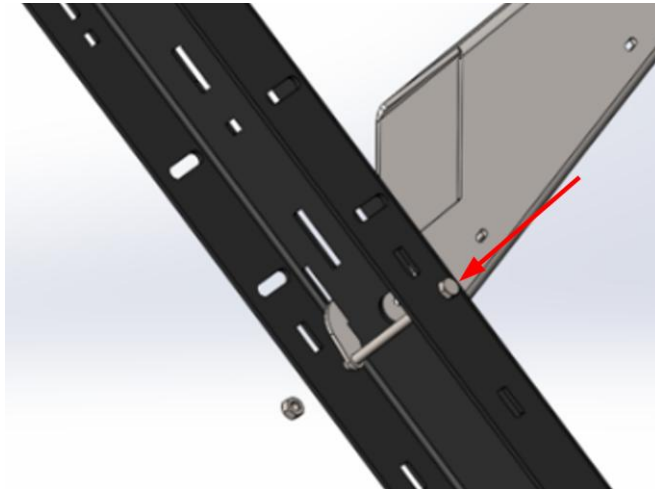

2.7. Attach the other end of the cross braces to the legs with two 5/16" x 3/4" carriage head bolts with flange nuts.

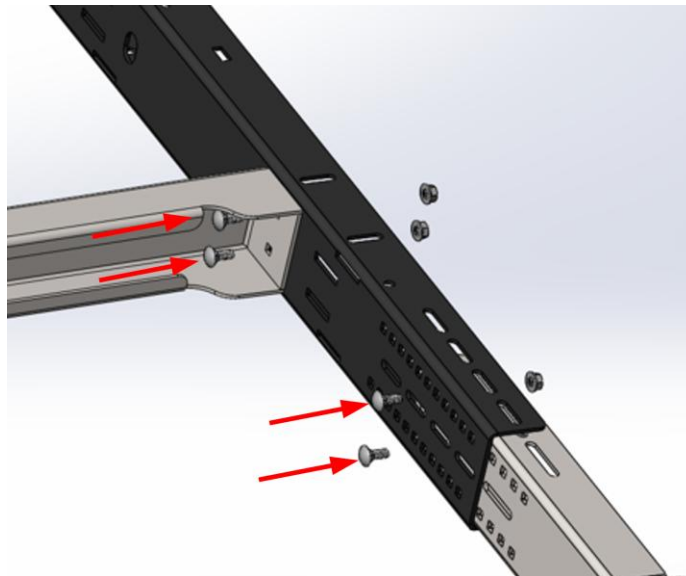

### 3. Connecting H-frames

Qty	Part #	Description	Pallet
36	51-1907	High Side Plate	2
36	51-2164	Low Side Plate	2
8	51-2179	X-Brace	2

- 3.1. After assembling two H-frames, locate two of each: belt support high side rails (pallet 2), belt support low side rails (pallet 2), two X braces (pallet 2).
- 3.2. Stand up both H-frames and attach them with 5/16" x 3/4" carriage head bolts and flange nuts using the parts located in the previous step on levels 1 & 6 only for now.

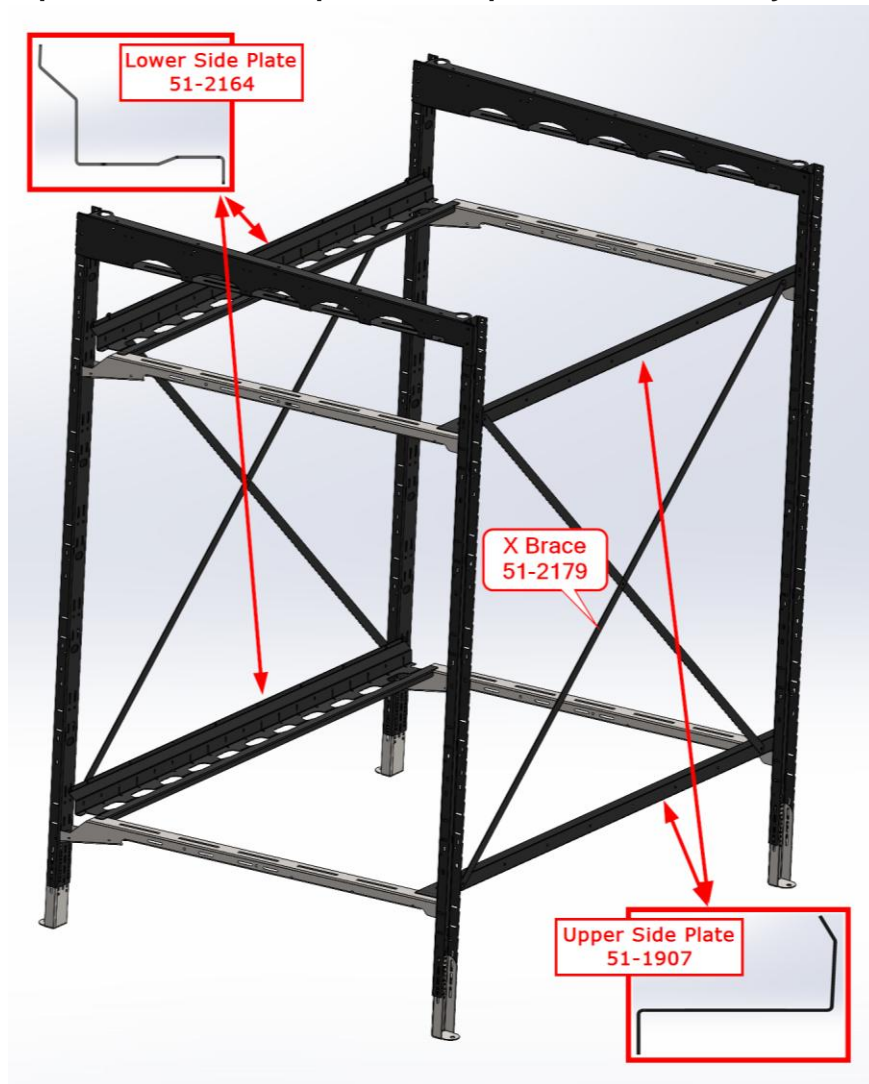

3.2.1. Some models may require “Wedge Shim” on high side plates to sit flat on cross members.

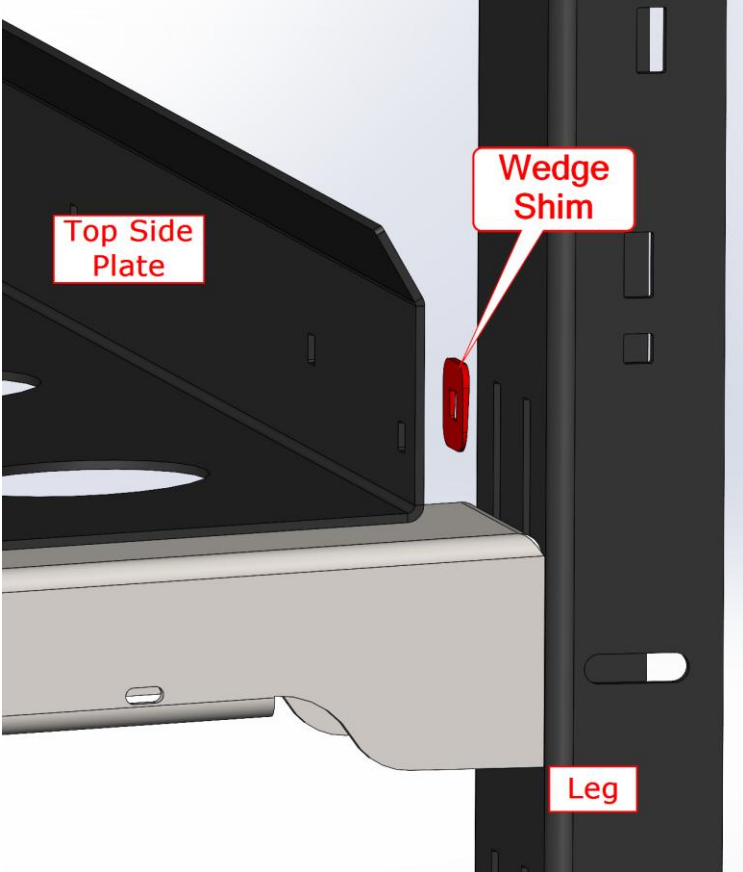

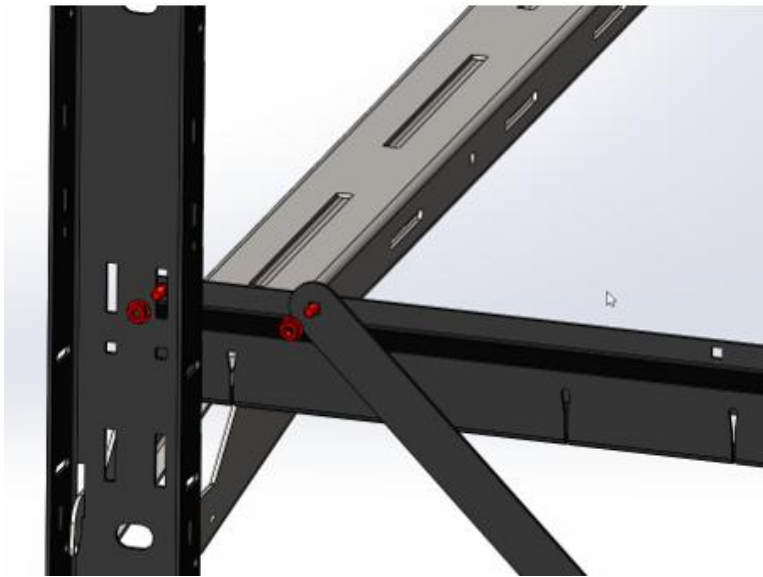

**1.1. Install X braces** on the side of section 1 and the top and side of section 2 as soon as you can to prevent excessive swaying of the **H-frames**.

**Note:** The X braces on section 1 will move to section 2 and a second set of X braces will be installed on section 5 after all sections are stood up.

**1.2. Continue to add H-frame sections** using **high/low side belt support rails** until all 6 sections are in place.

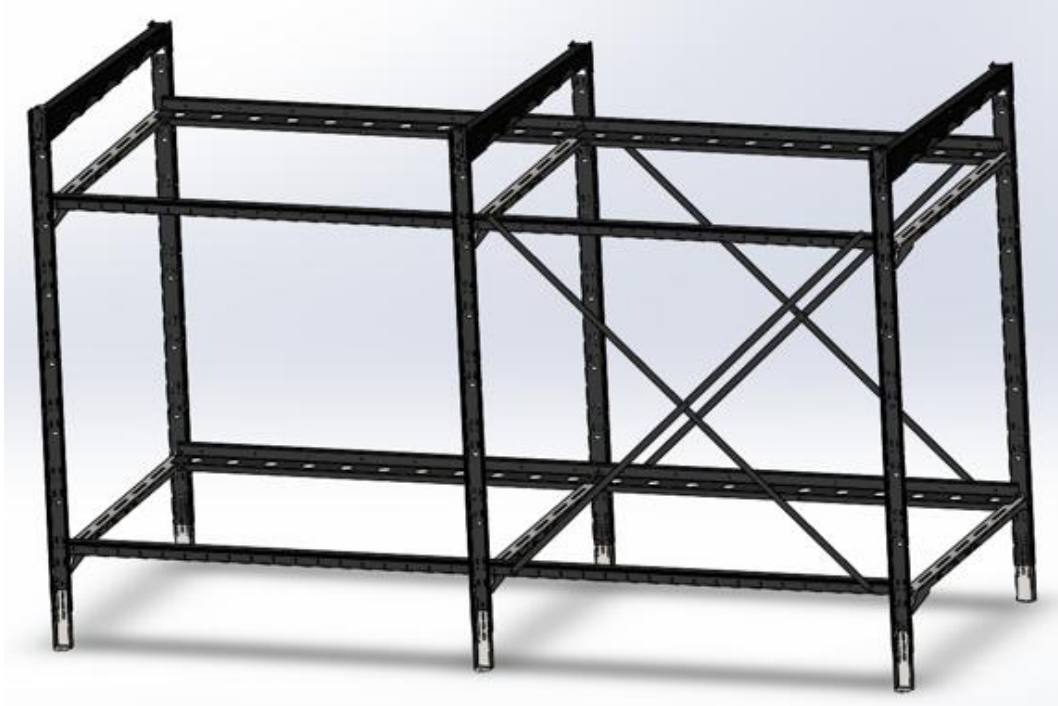

**1.3. Move the X braces** from section 1 to section 2.

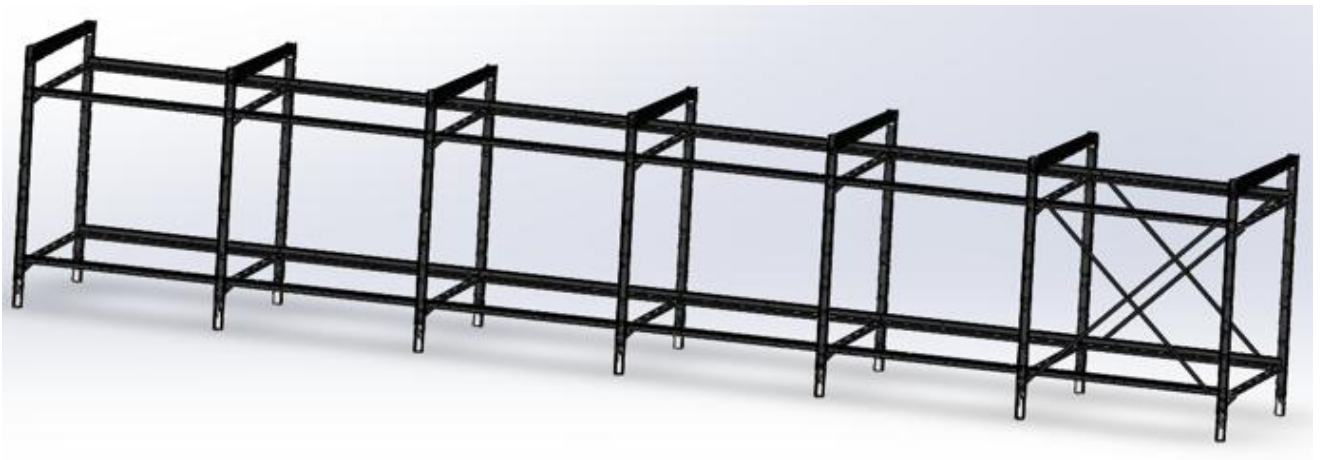

# 4. Table Leveling

- 4.1. The table legs are straight with the chalk line on the floor and the table square by measuring the corner to corner mark the location of the front legs on the floor.
- 4.2. Move the low side forward or the high side back from the marks  $\frac{3}{4}$ " resulting in the frame become out of square. This will allow the belts to roll up square.

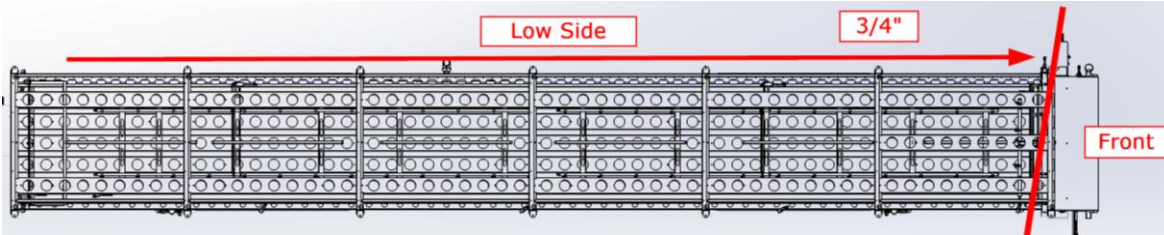

- 4.3. Measure the distance at each leg on the high side from the belt support high side to the laser line

Note: This will identify the highest spot (shortest measurement).

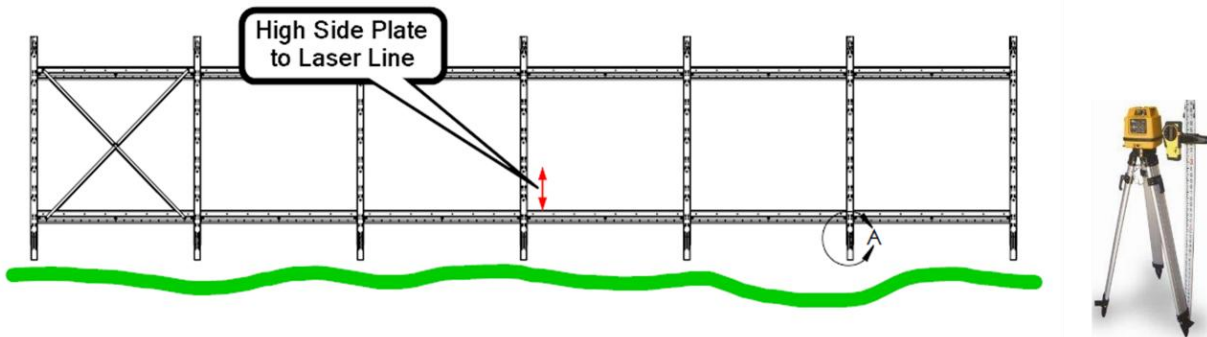

- 4.4. Use this measurement to jack each leg to this measurement and place two bolts in the aligned holes as shown below.

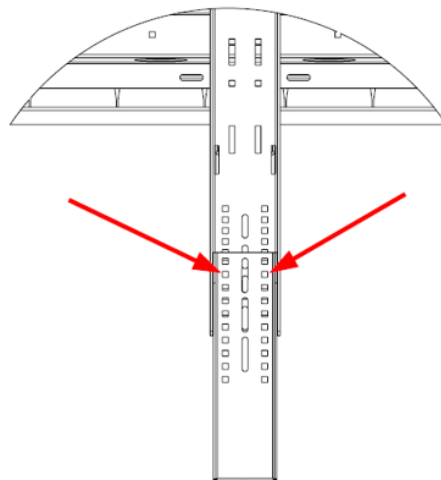

- 4.5. Place a level across the top cross brace and adjust the low side legs to level.

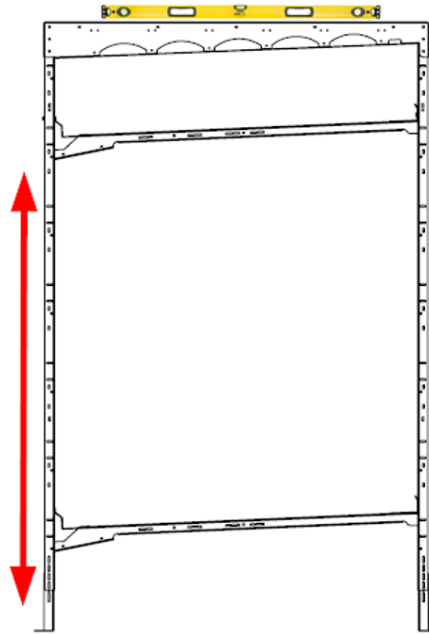

4.5.1. Each **leg** is leveled by placing a level vertically on the **leg** as shown by the red arrow below.

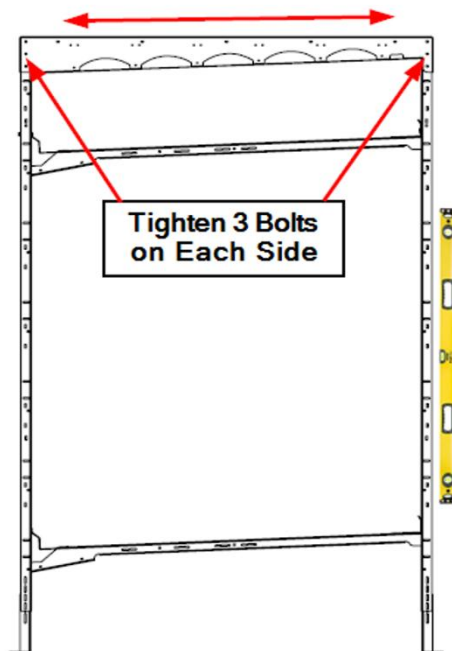

4.6. Tighten the carriage bolts on each leg when level.

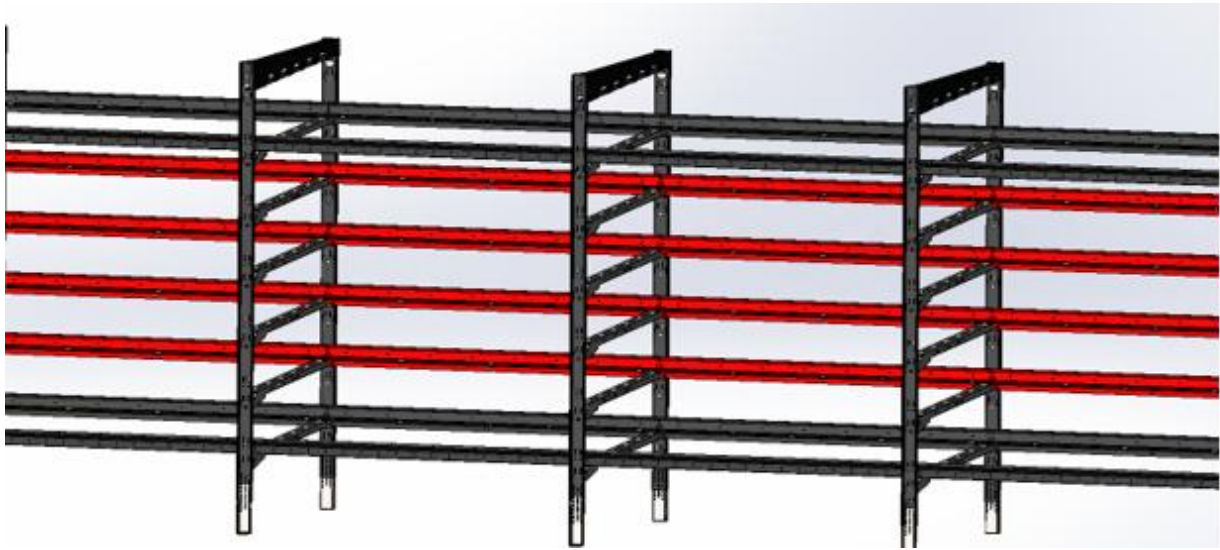

# 5. Belt Position Switches & Pans

Qty	Part #	Description	Pallet
1	30-0206	KIT, SENSOR, BELT POSITION, DGS	1

5.1. Install the front belt position switches to the low side pan on the outside face on sections 1 and 6 using machine screws.

**Note:** The belt position switch on the front of the table must be on the **low side**. The rear switches must be mounted on the **high side** of the table.

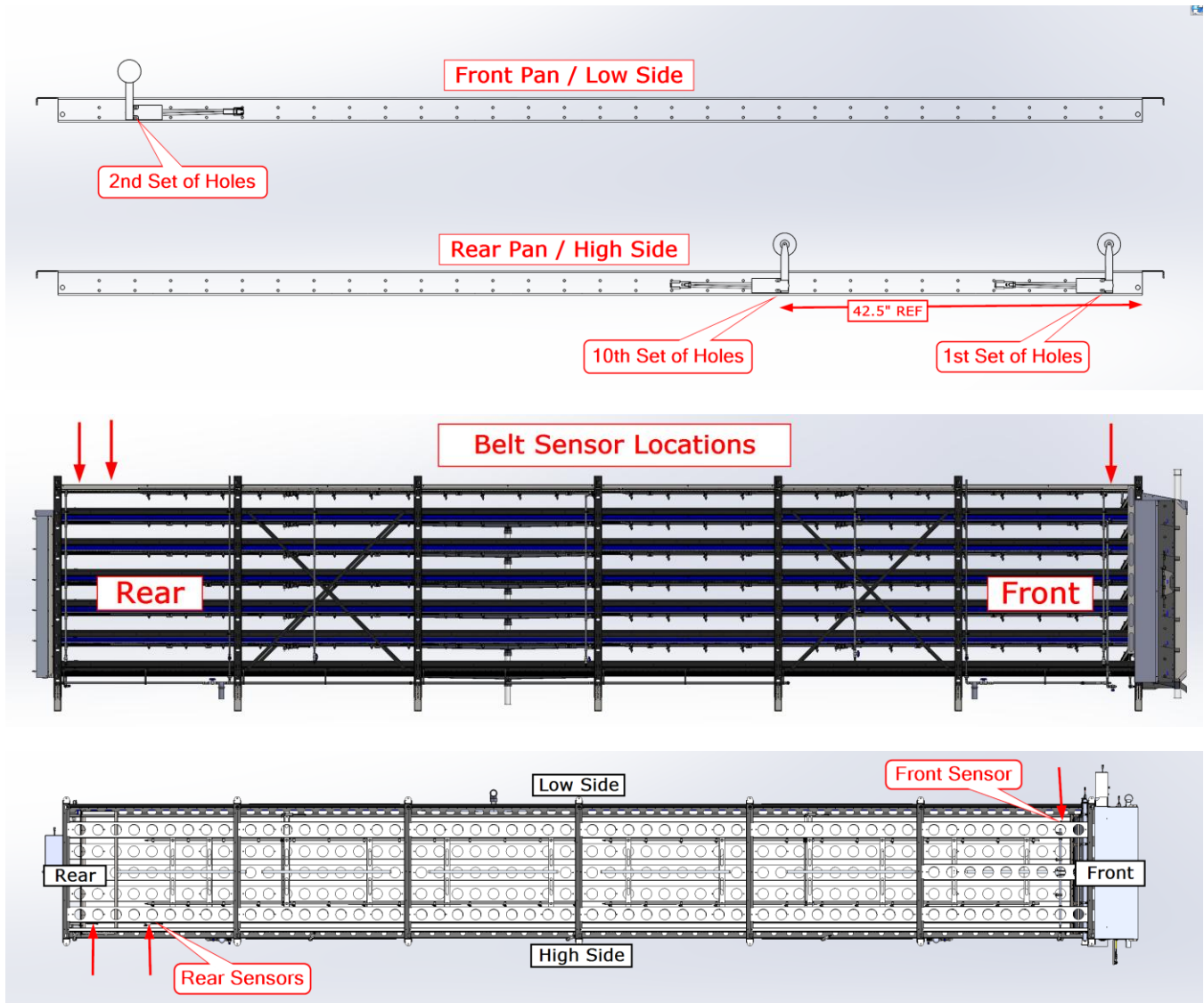

5.1.1. Adjust the switch arms so the wheel points straight up at a 90° angle by loosening the screw at the pivot point if necessary.

- ✓ The switch arm is extended.

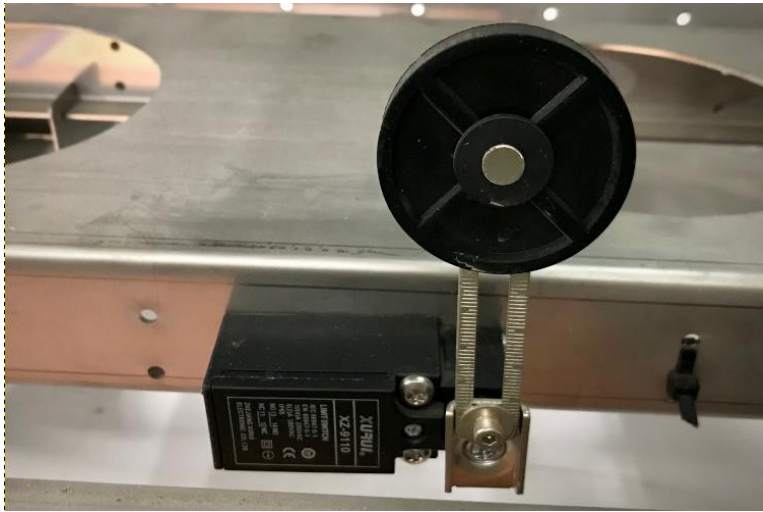

**5.2. Install three pans on the top level of the first section (harvest/front end) only.**

**Note:** The remaining sections of the top level get two outside pans.

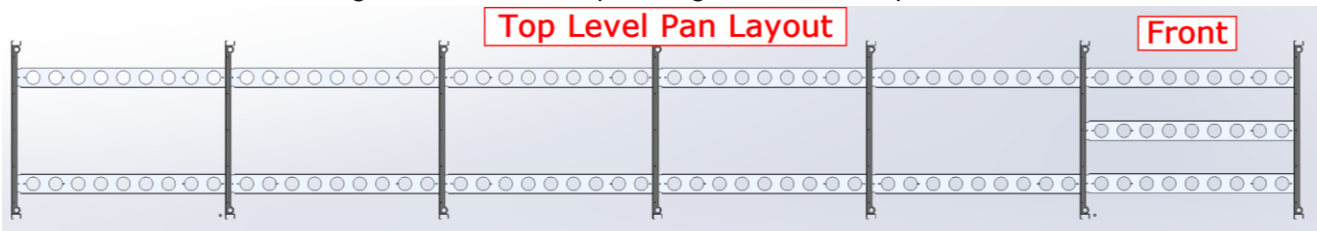

**5.3. Install all pans on lower sections.**

**Note:** First section gets 3 pans on the very top according to the image below.



## 6. Assembly Spray Booms

Qty	Part #	Description	Pallet
2	21-0045	Bundle, Spray Booms, DGS 66	8 & 9
1	30-0082	Kit, Nozzle Assembly, Yellow, DGS 66	11
1	30-0083	Kit, Nozzle Assembly, Blue, DGS 66	11

6.1. Attached Spray Nozzle Asm onto the holes one of the Spray Boom and Fasten with screw using a #3 Phillips driver.

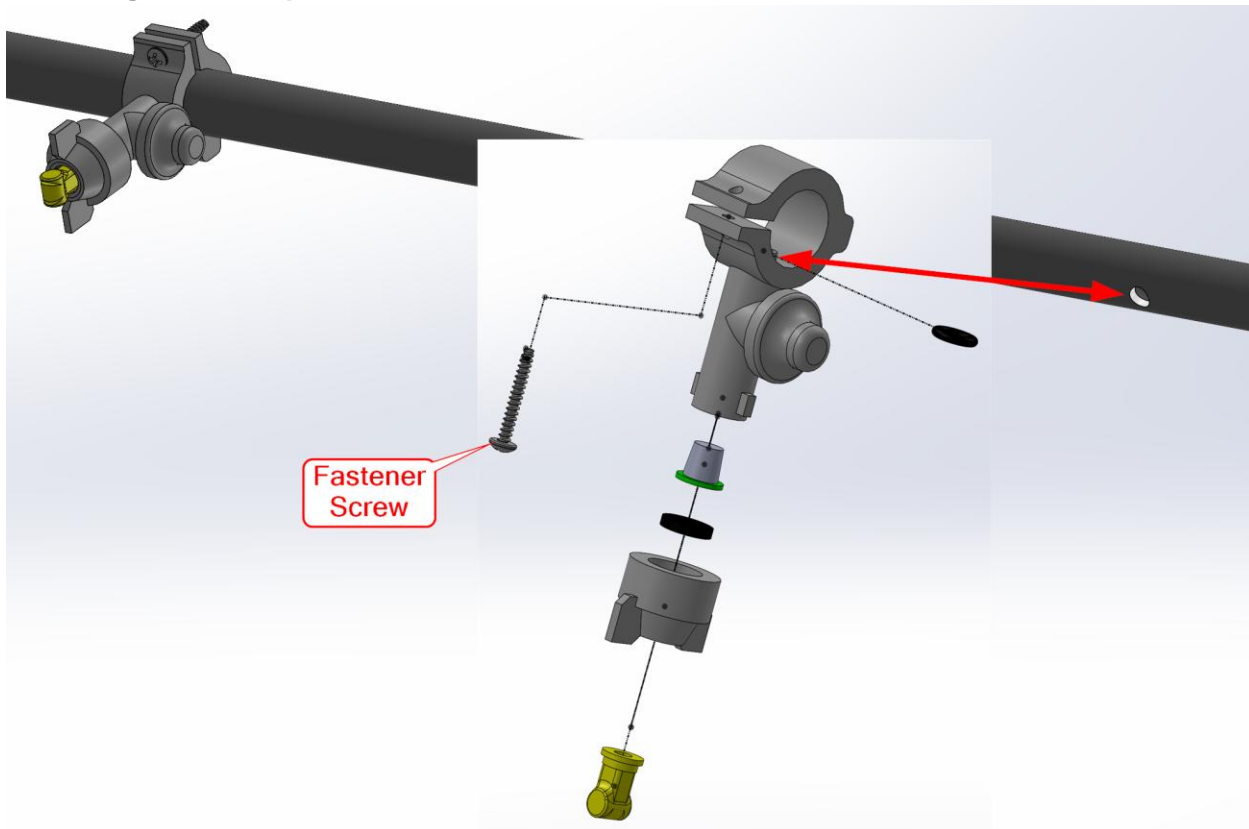

# 7. Spray Booms & Lighting

Qty	Part #	Description	Pallet
1	21-0030	Box, Spray Boom Mounts	11
1	21-0031	Box, Spray Boom & Spray Boom Motor Mounts	11
1	30-0008	Kit, Spray Boom Drive, DGS 66	1
1	30-0205	Kit, Light Harness, DGS 66	1
1	30-0506	Kit, Lights, DGS 66	1

7.1. Attach the spray boom motors onto the motor mounts with four M3x8 machine screws and 1 zip tie each.

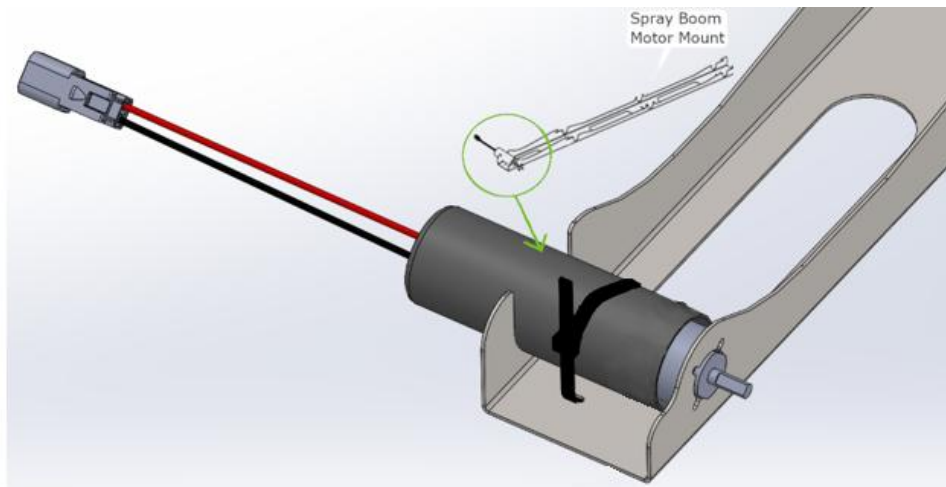

7.2. Lay out the spray boom mount brackets on pans following the measurements below.

**Note:** Take note of where the **spray boom motor mounts** are located. Do not install the brackets and **motor mounts** onto the bottom of the **pans** until the spray booms are in place so that when the brackets and motor mounts are raised, the **spray booms** are in place.

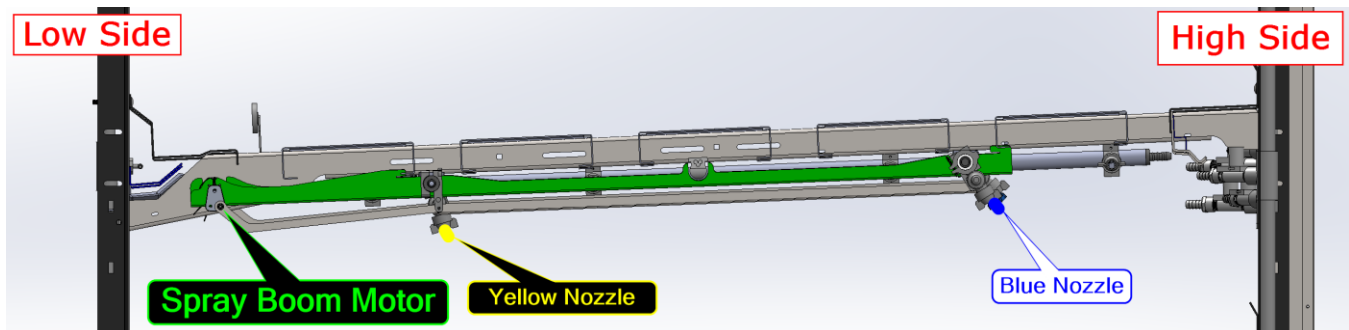

7.3. Divide each bundle of spray booms in half. Assemble one group with **BLUE TIPPED** nozzles(high side) and the other group with **YELLOW TIPPED** nozzles(low side).

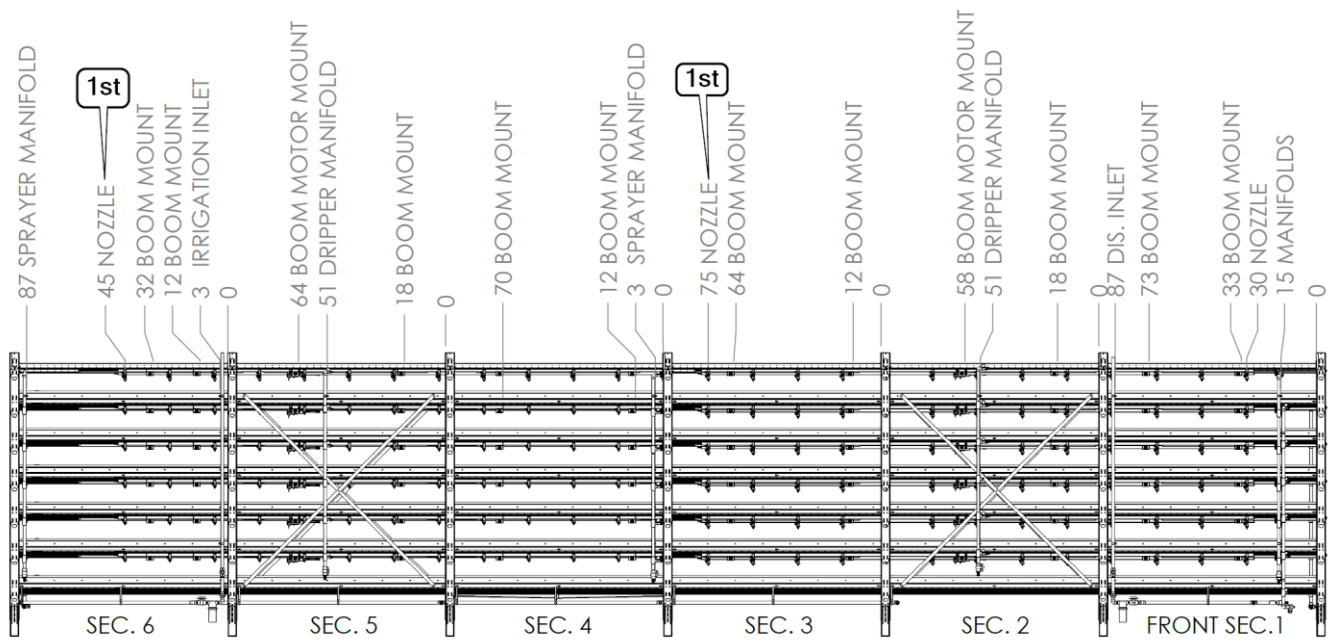

**7.4. Lay the spray booms in the outside slots of the spray boom brackets and motor mounts with the hose barb to the rear.**

7.5. Lay six lights per level in the middle slot of the spray boom brackets and spray boom motor mounts checking each light lens is secure in the channel.

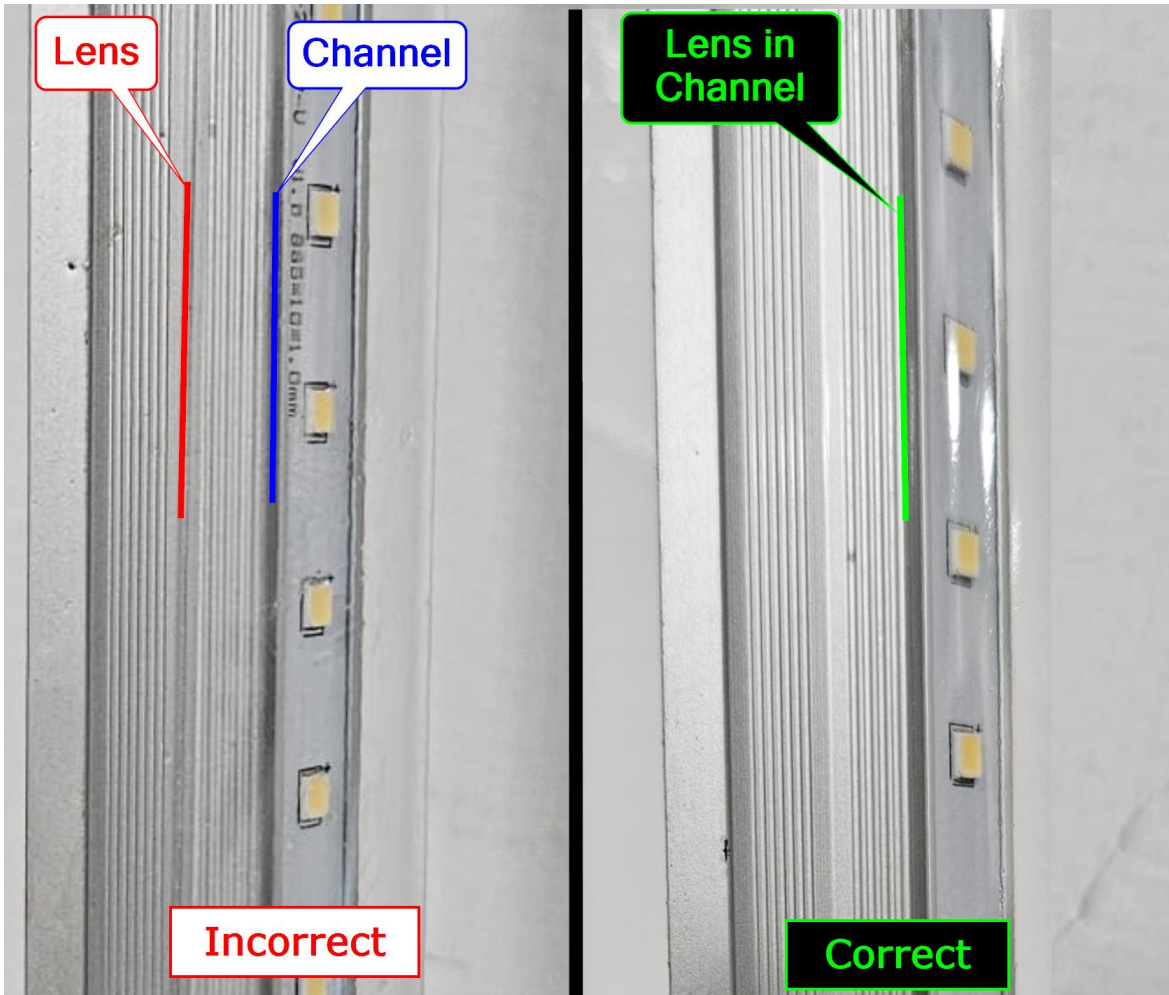

7.6. Daisy chain lights for sections 1, 2 and 3 together from the front and 4, 5 and 6 to the rear.  
**Note:** Secure lighting cables to the table with a slight dip in the middle to prevent moisture from running towards the light plugs in either direction.

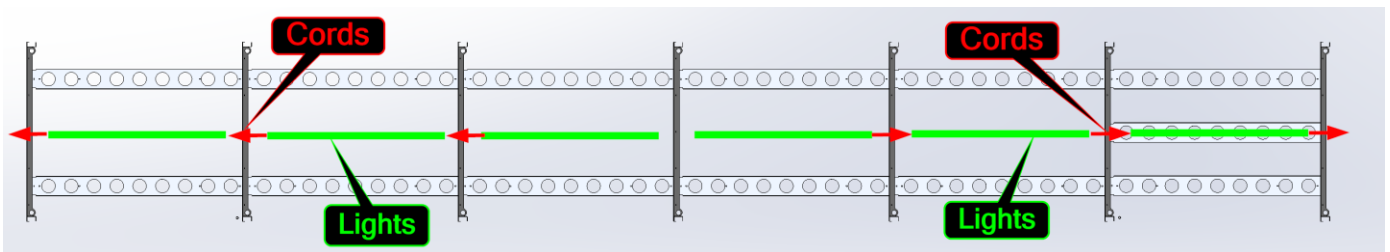

1.4. Install the spray boom brackets and motor mounts to the underside of the pans.

1.5. Begin installing the spray booms by lifting out one end of the low side pan slightly and angle it towards the center of the table, setting the pan end on the cross brace.

7.7. With the help of two people, lift the front spray booms to the pans.

**Note:** Have one person place the tabs of one side of the bracket into the slots on the underside of the high side pan while the other person lines up the tabs of the bracket with the low side pan slots.

**7.8. Once the tabs and slots are lined up on the low side, pull the pan back into place.**

**Note:** This will secure the bracket into place.

**7.9. Repeat the process for the remaining levels.**

**NOTE: Spray Boom Motors go on the LOW SIDE to avoid interference with dripper channel**

## 8. High Side Plate & Drippers Installation

Qty	Part #	Description	Pallet
1	30-0010	Kit, Plumbing, Drippers, DGS 66	1
30	51-1913	Dripper Channel	6
36	51-1914	Dripper Channel Cover	6
6	51-1947	Dripper Channel Top Level	6
12	35-0025	Dripper pipe assembly	11

8.1. Install the remaining high side plates on level 2-5 fastening them with 5/16" carriage head bolts and flange nuts.

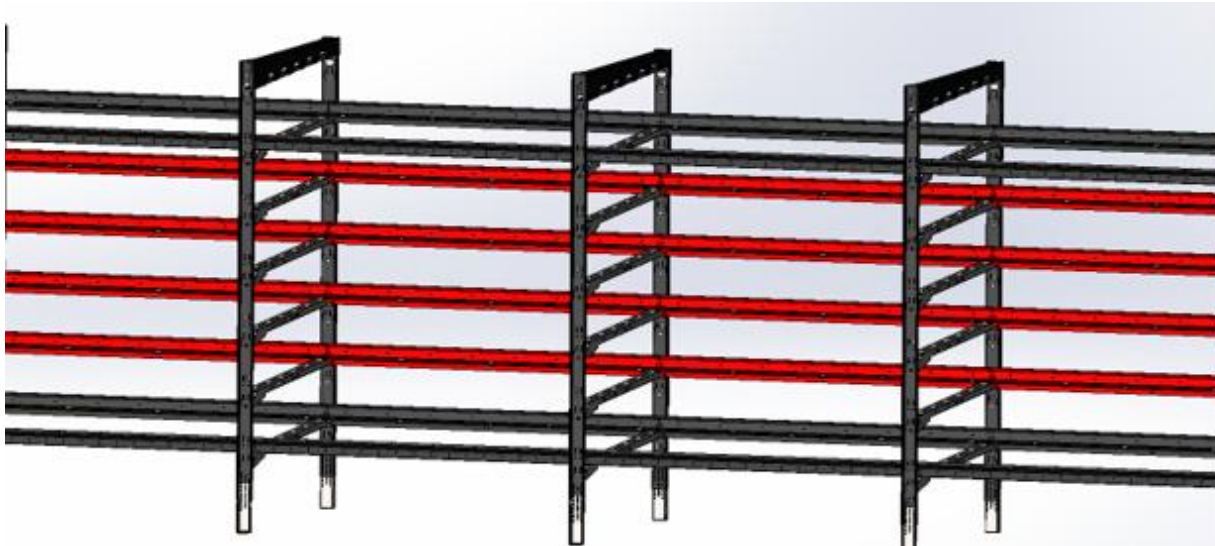

8.2. Line up the center slots on the dripper, dripper cover and high side plate loosely fastening it with 5/16" carriage head bolt and flange nut.

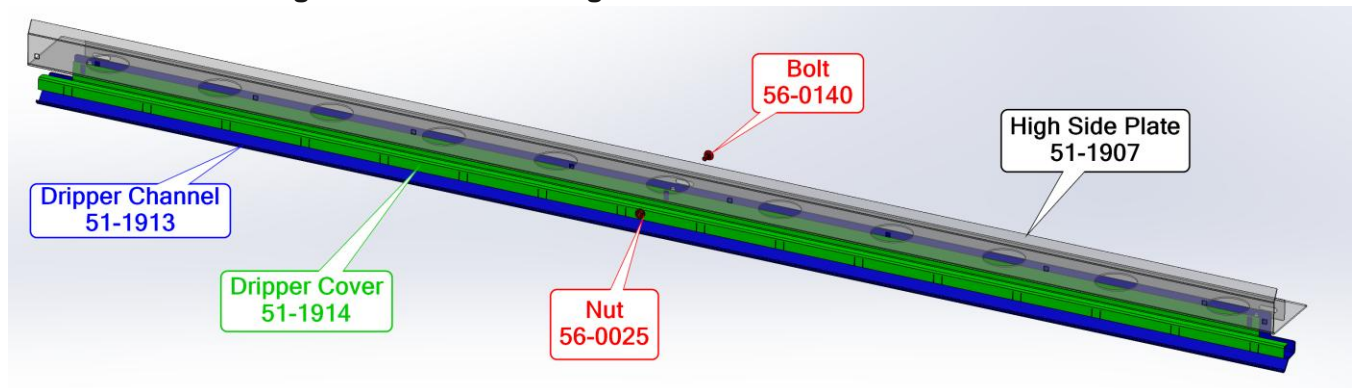

Install the top level dripper channel (51-1947) between the top plate and fasten with 5/16" carriage head bolts and flange head nuts loosely.

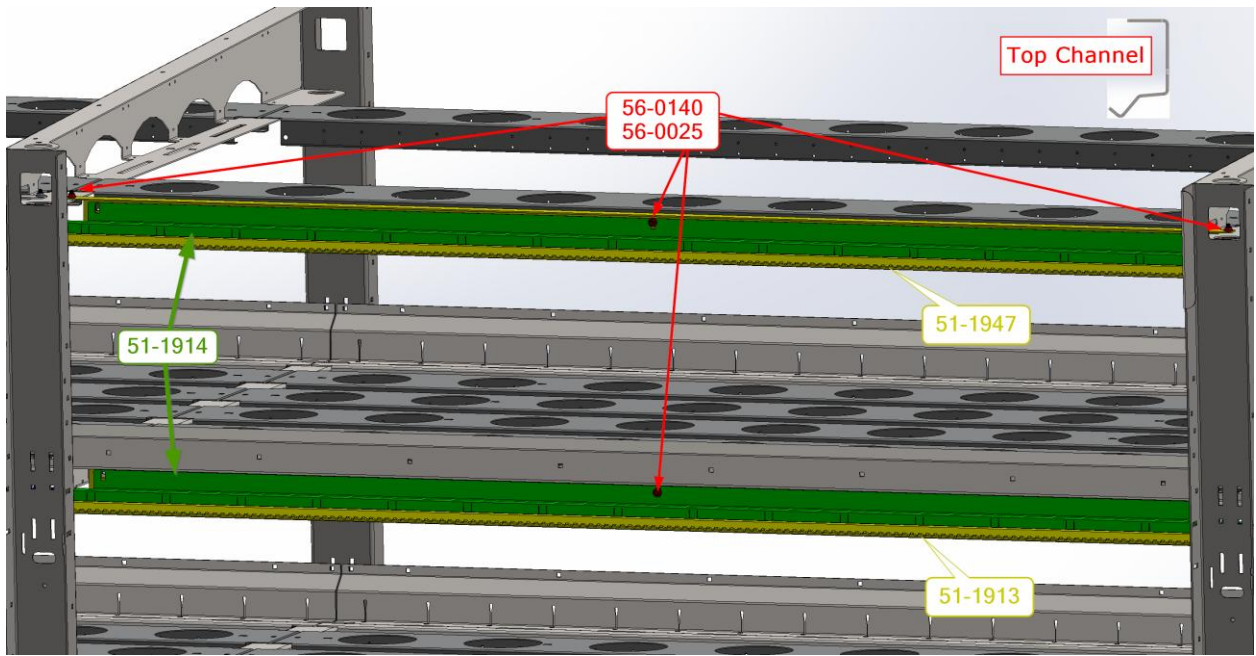

**8.3. Use two more nuts and bolts to loosely secure the ends to the belt support top.**

**Note:** Leaving the hardware loose allows the **dripper pipe** to be inserted later in the manual.

**8.4. Repeat this process until all the dripper and dripper cover pieces are in place.**

**8.5. Install the dripper pipe assembly in between the dripper and the dripper cover on the high side of the table.**

**Note:** Use a flathead screwdriver to pry apart the **dripper** and **dripper cover** so that the **dripper pipe assembly** can more easily slide into place.

**8.6. Pry up the correct tabs of the dripper cover (listed below) so that the hose barb of the dripper pipe assemblies can be attached to the manifolds that will be installed next.**

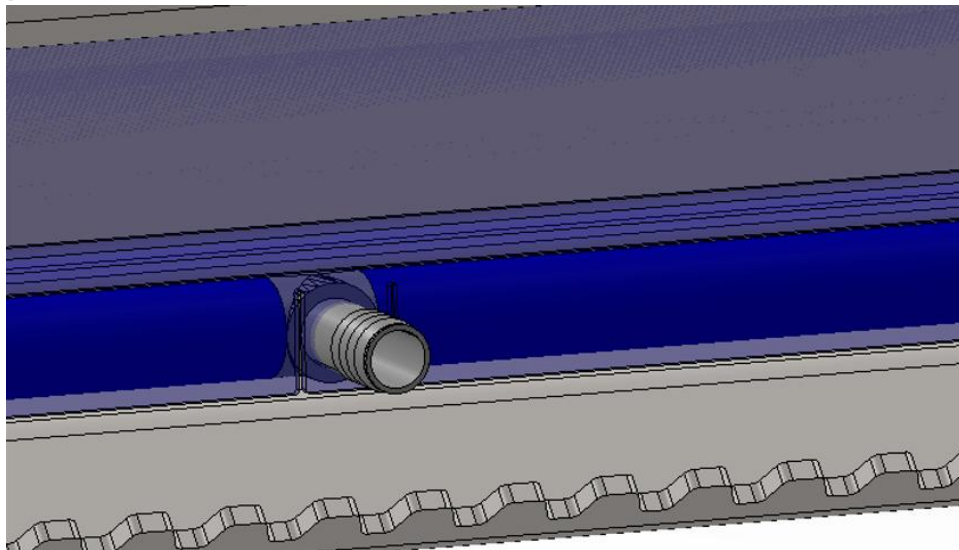

Dripper Tabs	
Section	Tab
Rear	6 <sup>th</sup> tab as shown below
Front	6 <sup>th</sup> tab as shown below

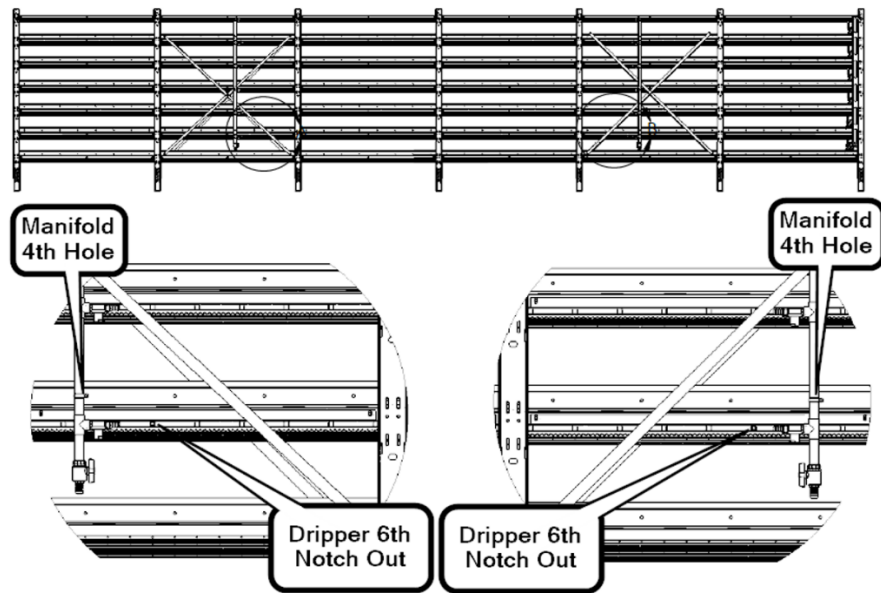

## 8.7. Dripper alignment.

8.7.1. Beginning at center leg, maneuver drippers of sections 3 and 4 to be touching as close to the center of the leg as possible.

Note: Ensure the head of the carriage head bolt is in the center of the slot on the high side belt support before merging drippers of sections 3 and 4. Vertical adjustments may be necessary to properly align each section's dripper channel.

8.7.2. Fully tighten flange nuts onto the three carriage head bolts previously left loose on the dripper.

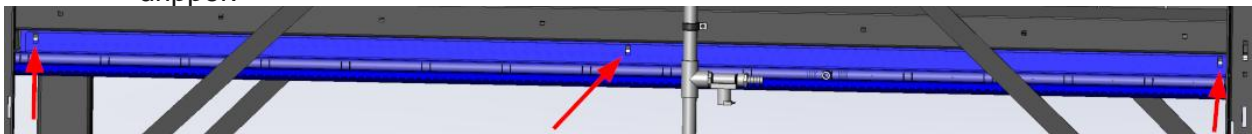

8.7.3. Once sections 3 and 4 drippers are properly aligned and fixed into position, butt the end of the dripper for section 2 to the dripper for section 3 as well as section 5 to section 4. Repeat for sections 1 and 6.

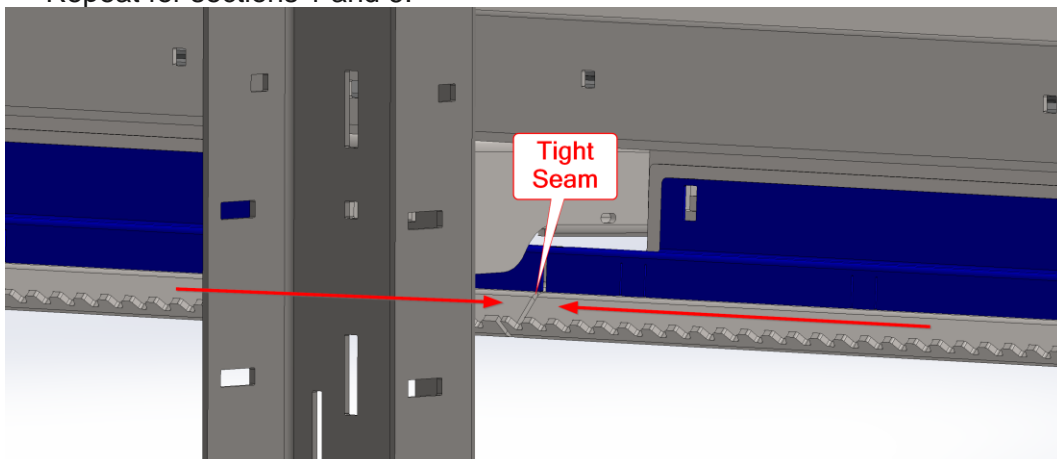

Note: There should be **little to no spacing** horizontally or vertically between each of the dripper sections if properly aligned.

8.7.1. Once the drippers are secure we will align the dripper hose by crimping in the tabs to align the hose in the channel. Crimp the tabs in 1/8" to align the tube to the back of the channel without pinching the tube.

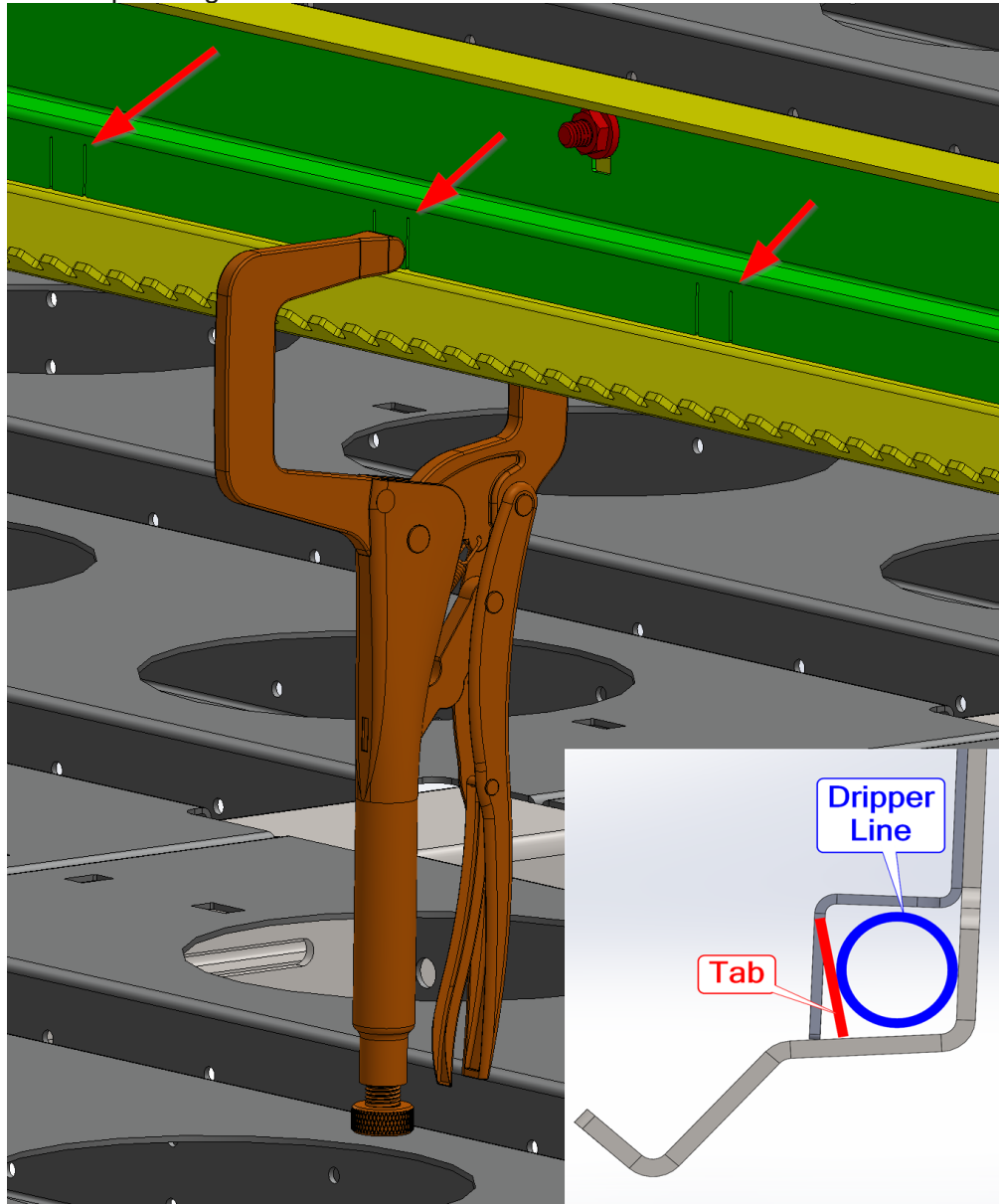

8.7.1. Cut the flex tap into 2" x 4" strips

8.7.2. For best results clean the seam area with a solvent

8.7.3. Place the 2" strips centered up on the seam starting flush detent of dripper grooves pressing the air out as you place the tape on the bottom side of the seam

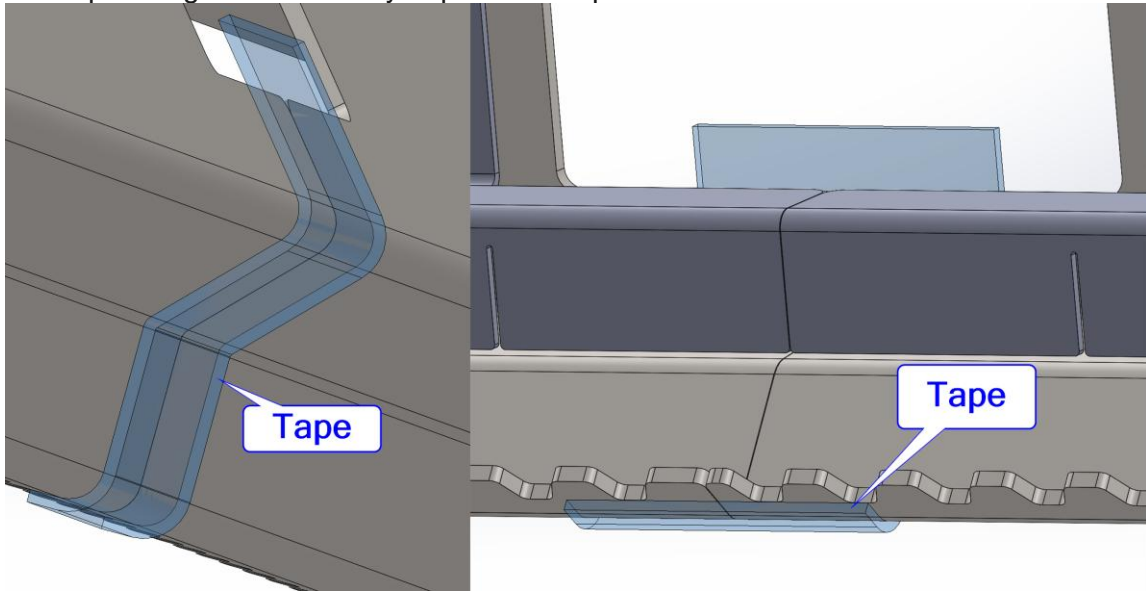

8.7.4. Install a caulk dam on each end of the dripper channel. Open the tab on each end of the dripper channel and apply a heavy bead of caulk.

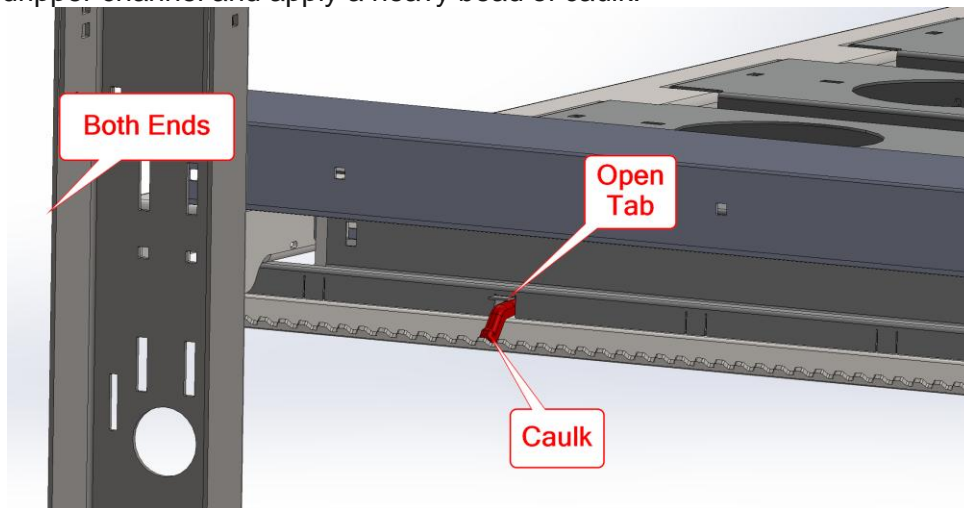

# 9. Water Manifolds

Qty	Part #	Description	Pallet
1	30-0007	Kit, Irrigation	1
1	30-0009	Kit, Plumbing, Spray Boom	1
1	30-0010	Kit, Plumbing, Dripper	1

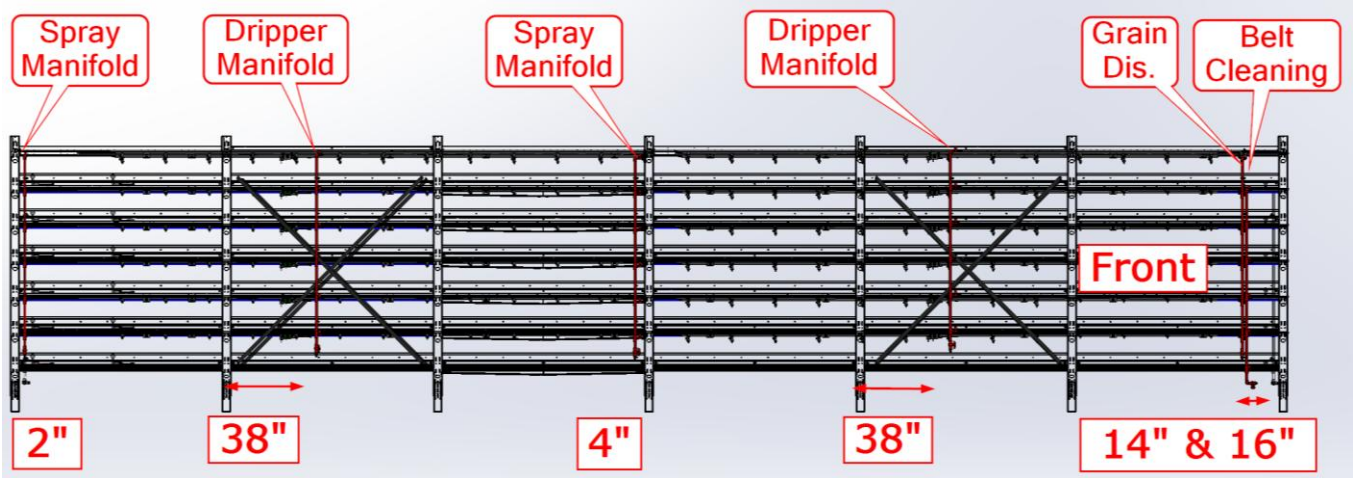

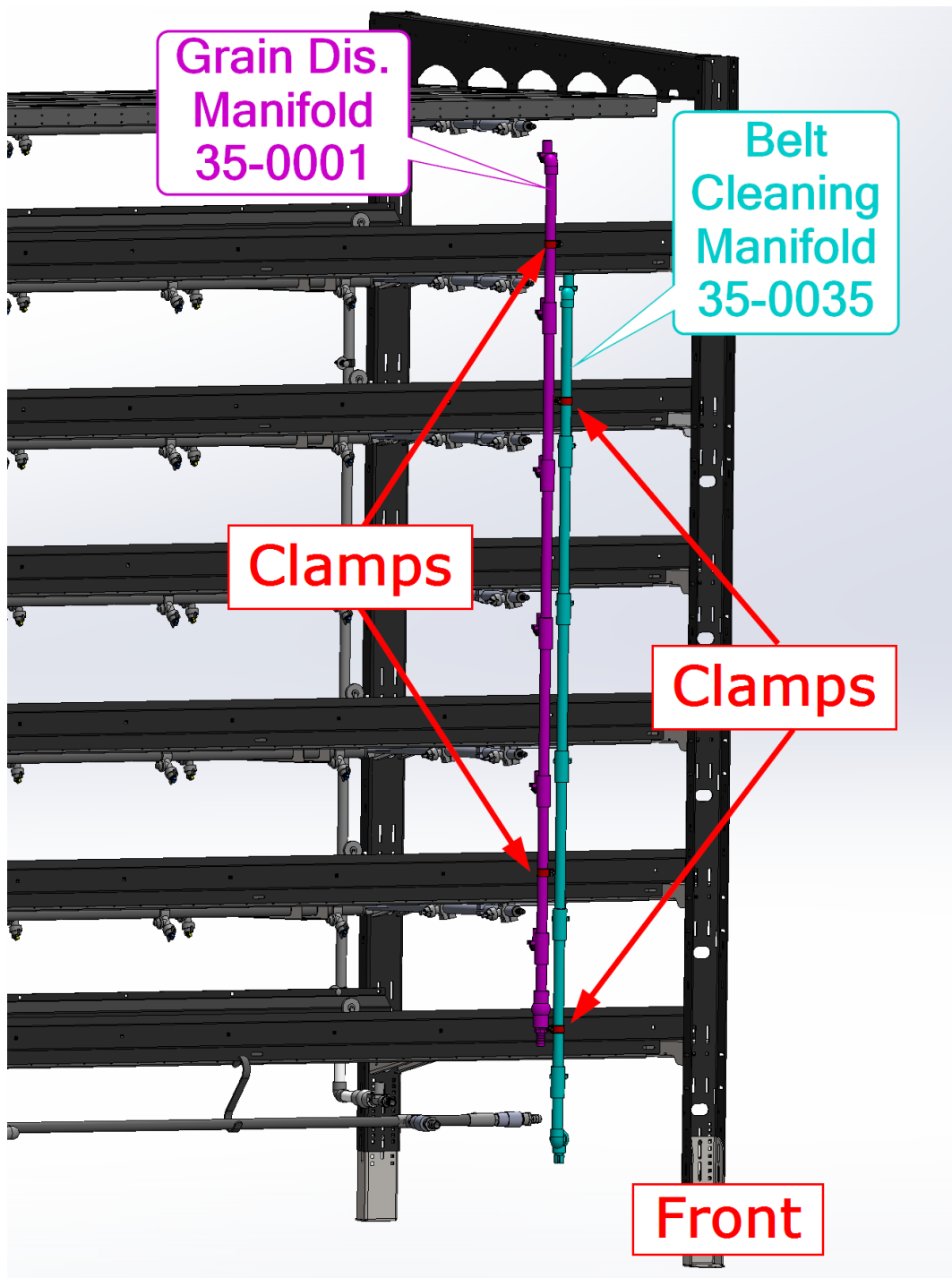

9.1. Install manifolds.

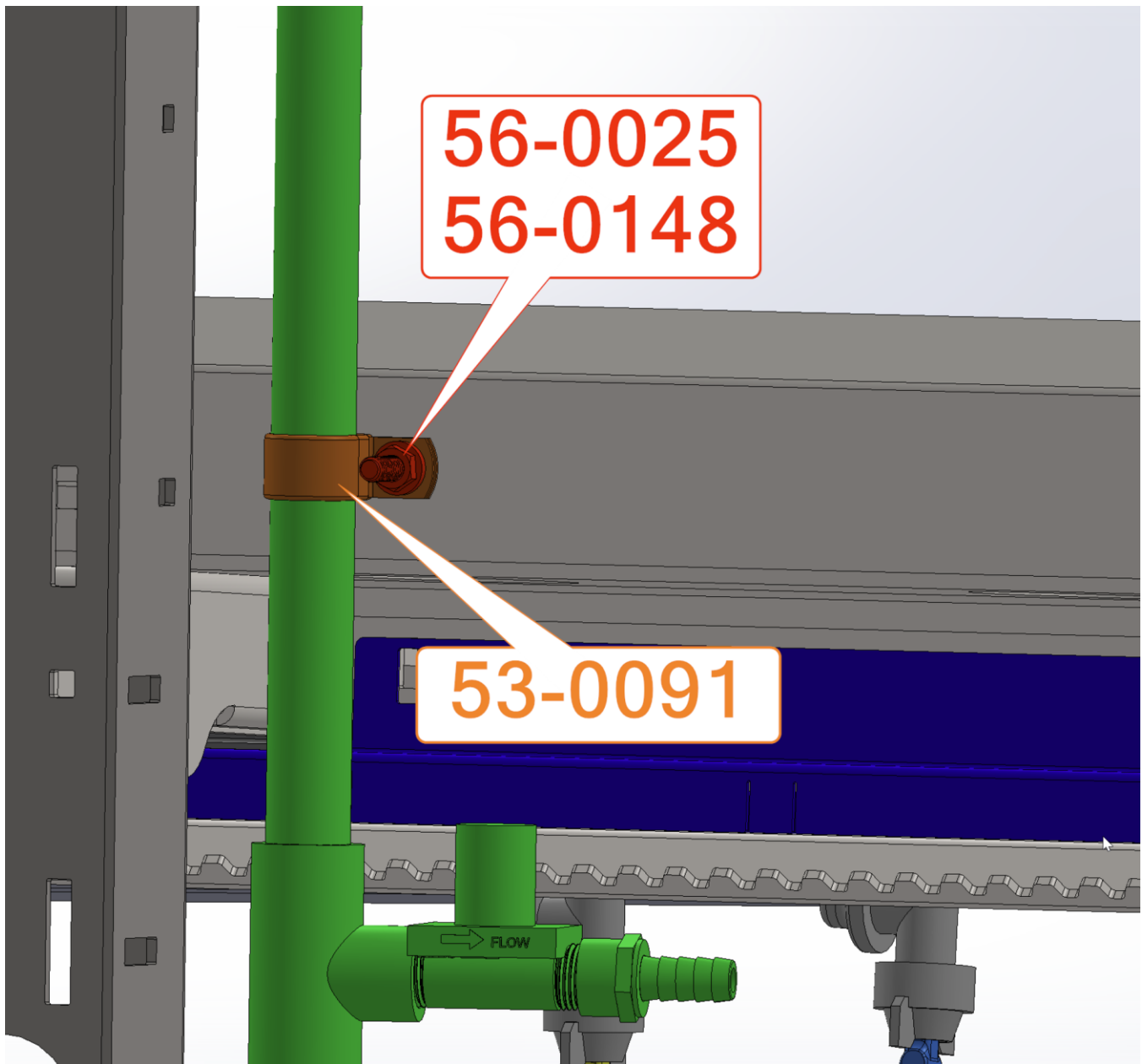

## 10. Install the Grain Disinfectant Boom

---

30-0006

10.1. Install disinfectant spray boom (35-0012) with mounting bracket (50-0180) with two cable ties (30-0164).

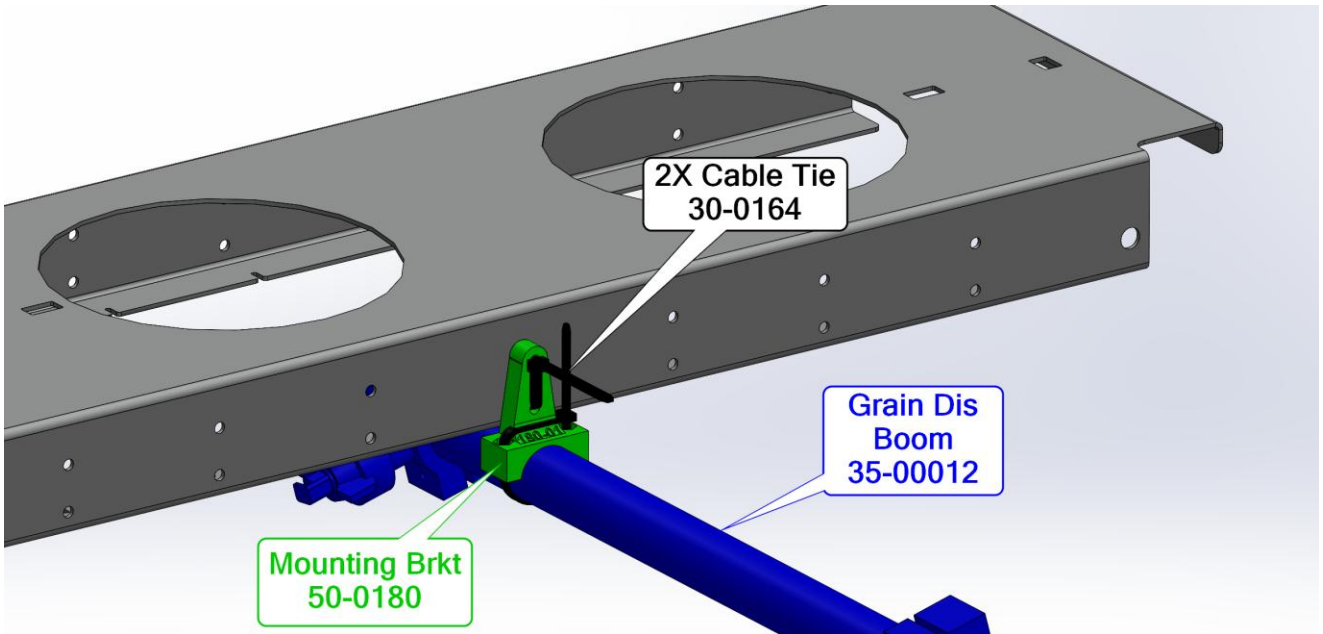
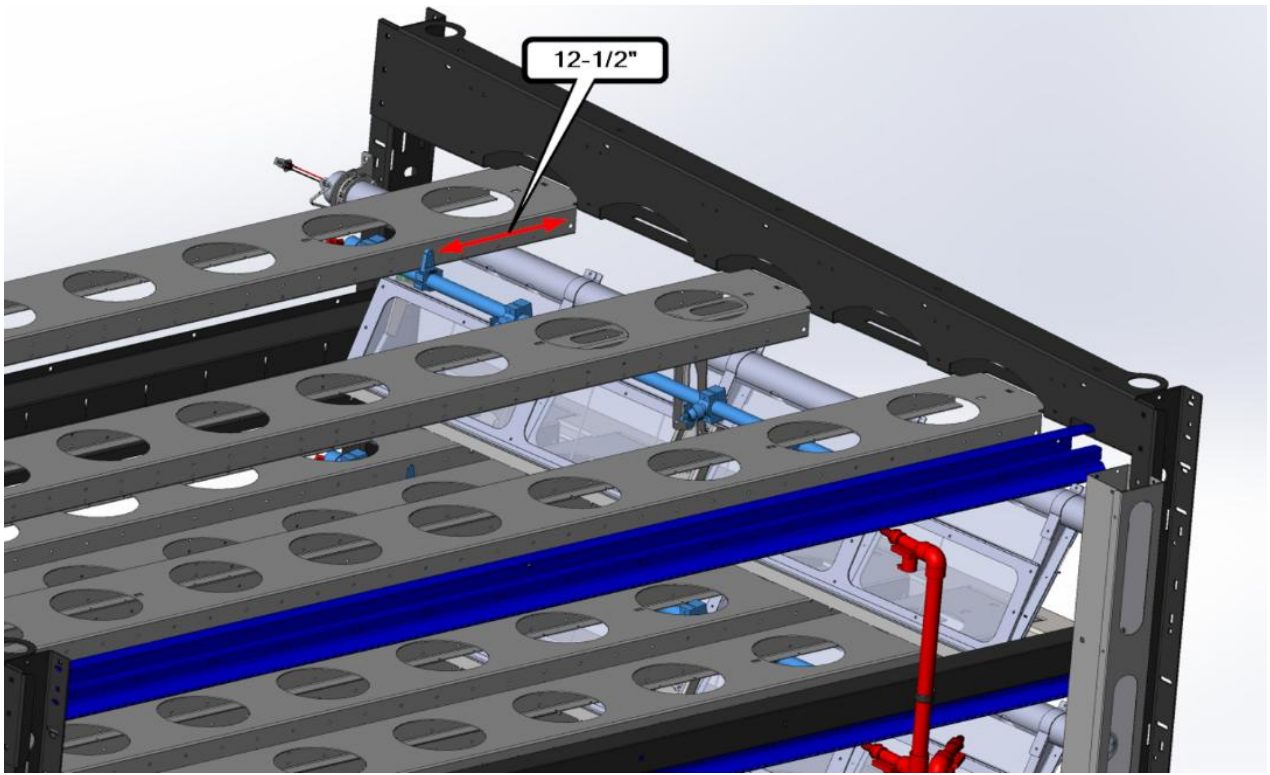

10.2. Align the nozzle to spray straight down and adjust the outside nozzles to spray to the outside edges of the table.

10.3. Adjust the water pressure to spray a steady flow of disinfectant water without washing the grain off the table.

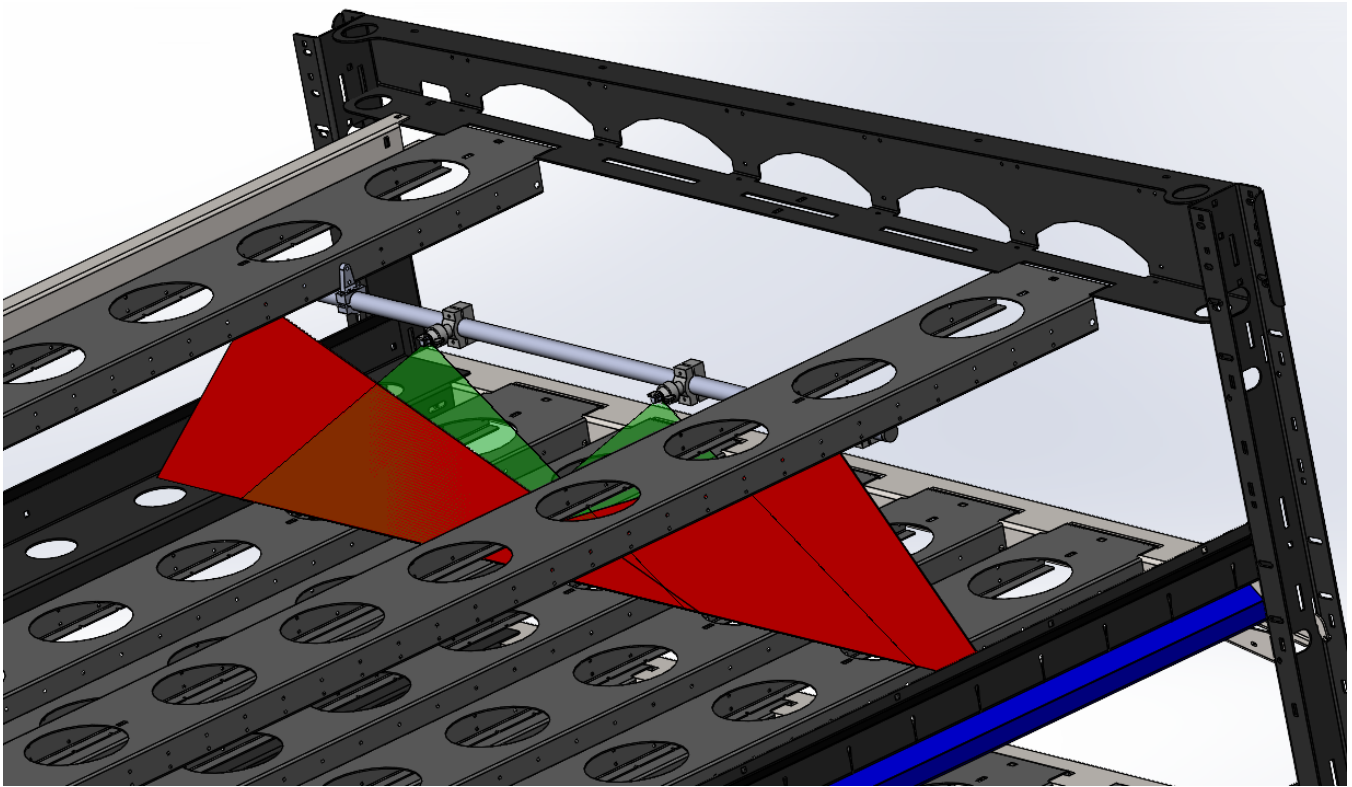
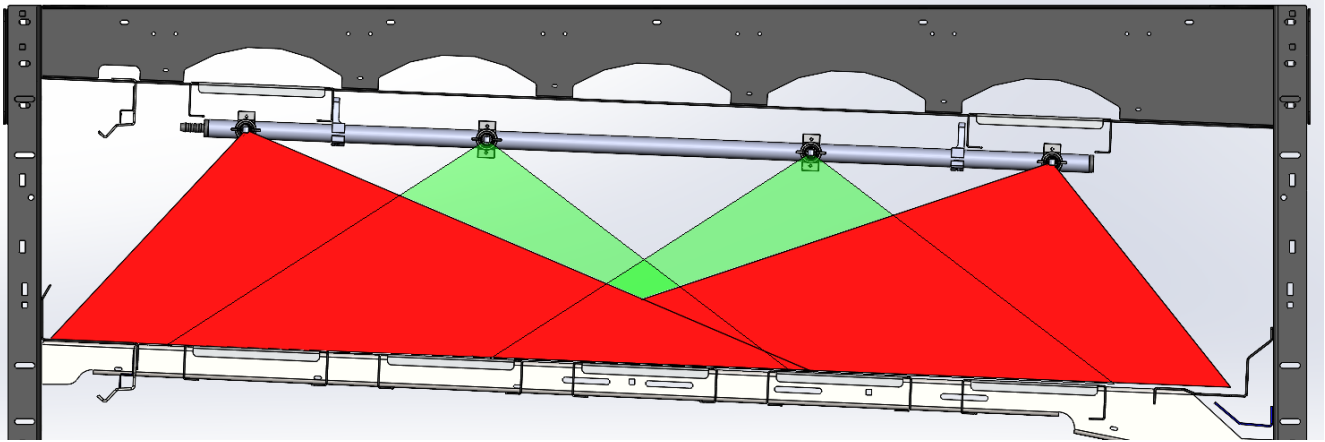

# 11. Install Spray Boom Hoses

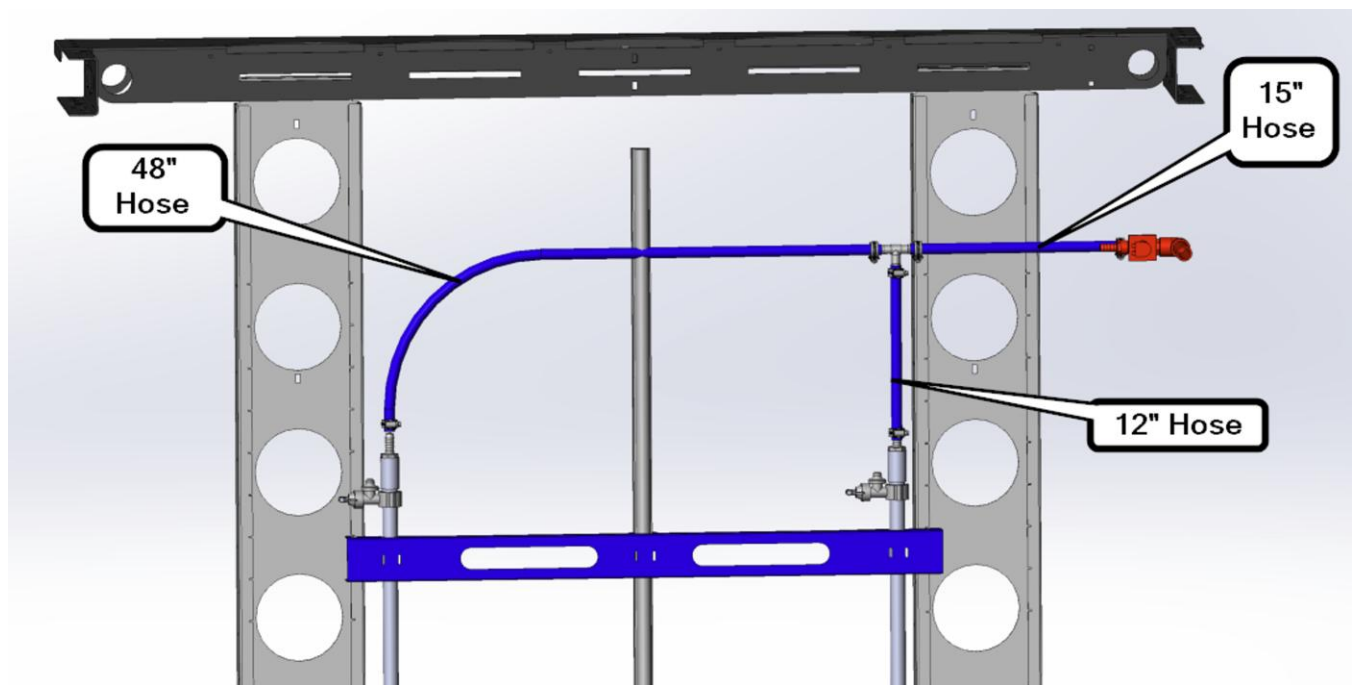

11.1.1. Mount the manifolds to the high side of the table.

**Note:** Use the tubing clamps and bolts from the 30-kits to attach the manifolds to the holes in the **belt support top**. The **seed disinfectant boom manifold** and the **belt cleaning manifold** will be clamped using the same holes.

11.1.2. Install the disinfectant spray boom using zip-ties and the disinfectant spray boom mount.

**Note:** Loosely zip-tie the boom to the mount.

11.1.3. Zip-tie the mounts to the **pans**.

## 11.2. Install spray boom hoses.

**Note:** Grease the hose barbs with white grease to help slide the hoses over them.

11.2.1. Secure the hoses onto the hose barbs with **hose clamps**.

✓ Check hose clamps are secure.

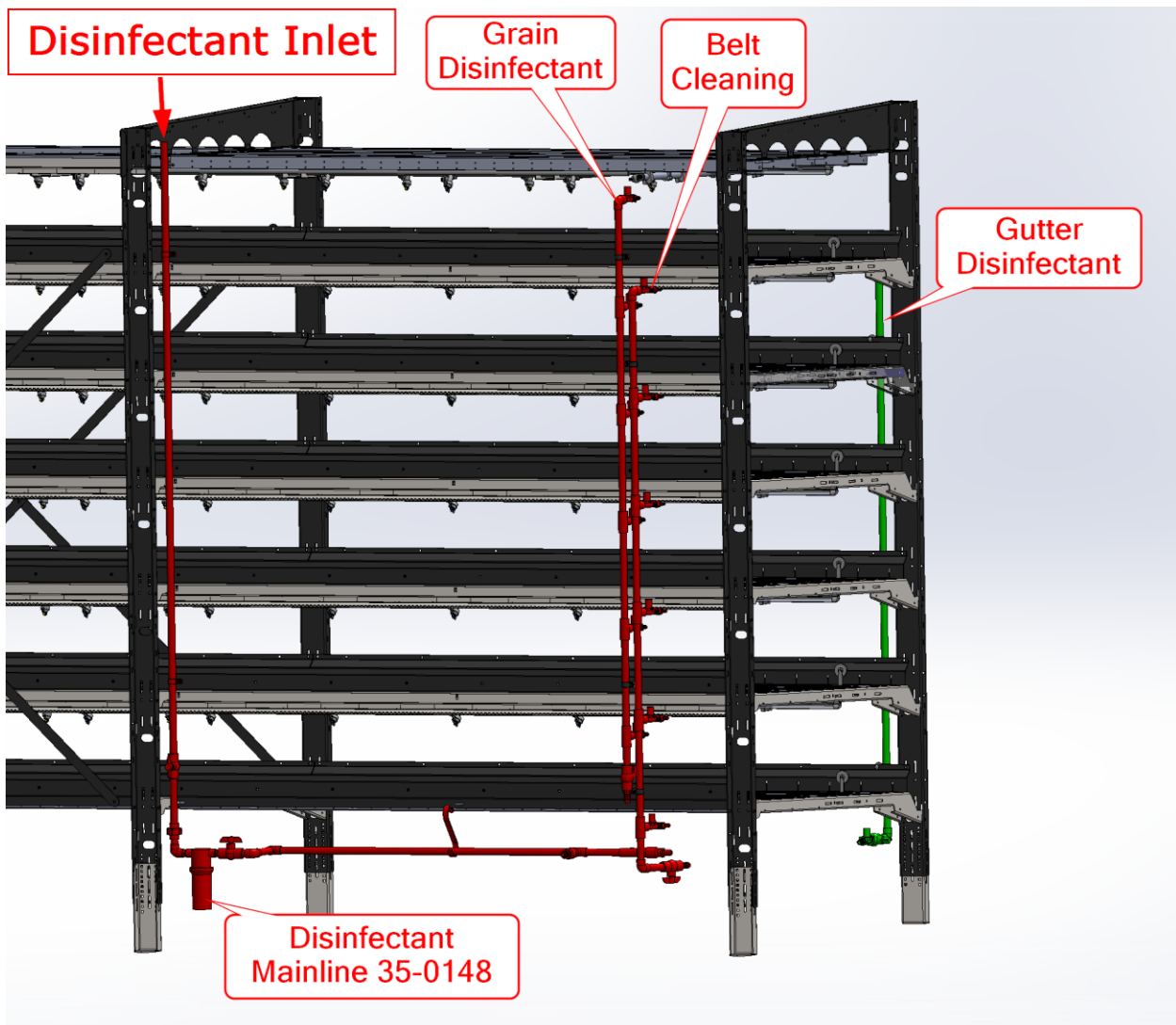

# 12. Seeder Assembly & Installation

Qty	Part #	Description	Pallet
1	30-0001	Kit, Seeder Install	1
1	30-0004	Kit, Pneumatics Rear	1
1	30-0015	Kit, Polycarbonate Install	1
1	30-0017	Kit, Consumables	11
1	51-2168	Seed Reservoir Body	9
1	51-2184	Seed Reservoir Face	9

12.1. Locate the lift cylinder from kit 30-0001.

12.2. Rotate the cylinder so that the air fittings point to the low side of the table.

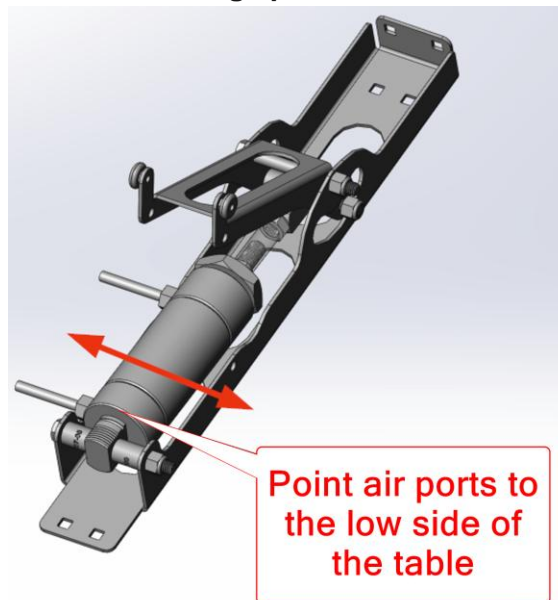

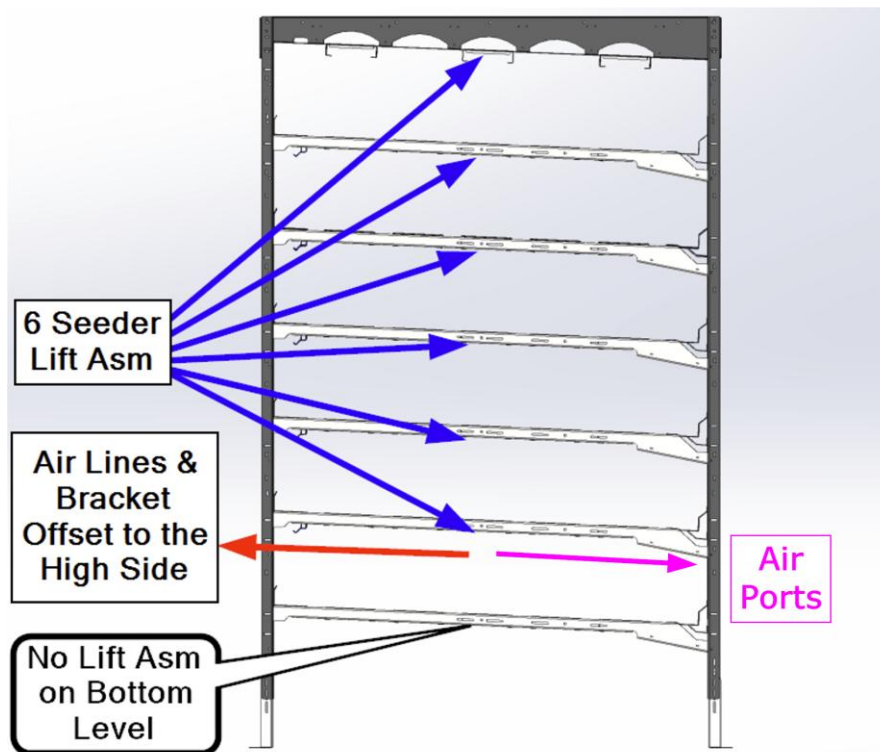

12.2.1. Install the **lift cylinder** assembly to the front **cross brace** and the underside of the middle **pan** offsetting the assembly to the high side fastening with 5/16" carriage head bolts and flange head nuts.

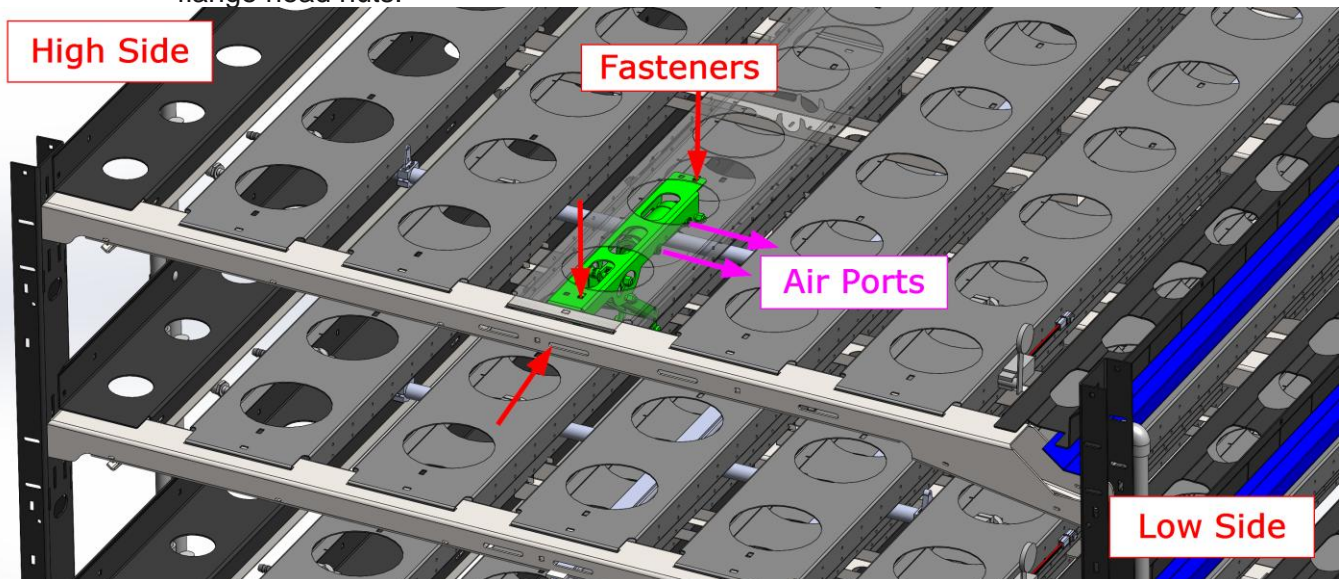

12.3. Install the seed reservoir.

12.3.1. Mount the reservoir body 51-2168 to the front high side leg fastening it with two 5/16" carriage head bolts and flange nuts snug.

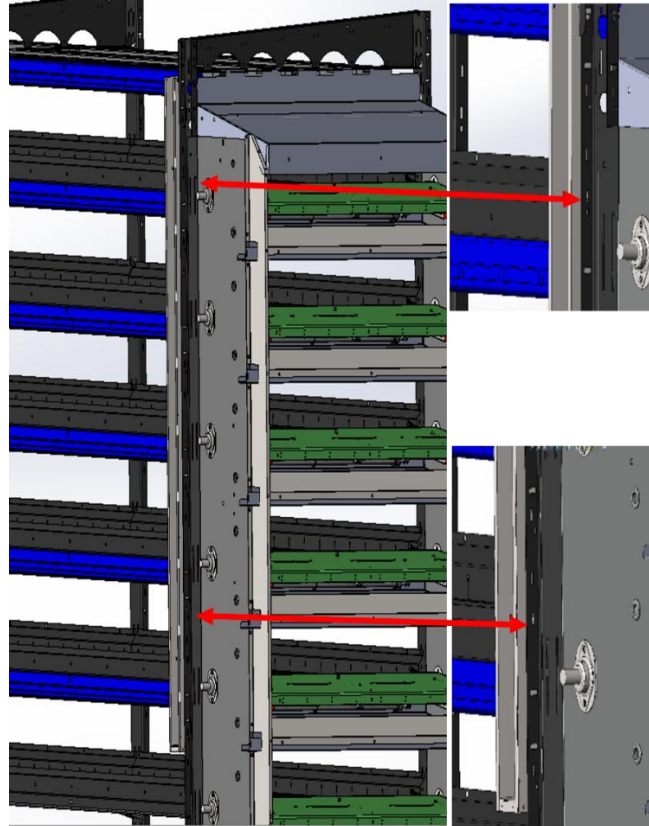

12.3.2. Cover the blank holes on the opposite of the mounting holes with carriage head bolts

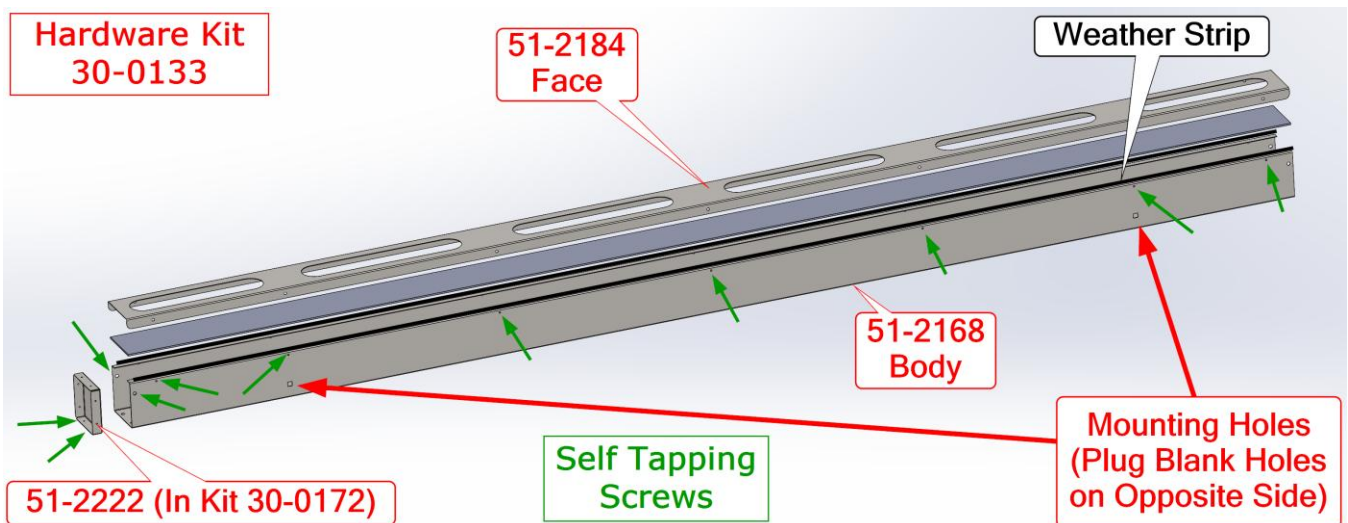

- 12.3.3. Locate **weather stripping** from the kit and install it onto the front edge of the **seeder bin frame**.
- 12.3.4. Sandwich the seed reservoir polycarbonate between the seeder bin frame and the seed reservoir face plate.
- 12.3.5. Use self-tapping screws to attach the **seed reservoir face plate** to the **seeder bin frame**.
- 12.3.6. Once the **seed reservoir face plate** is attached, use self-tapping screws to attach the **seed reservoir cap** to the bottom of the **seeder bin frame**.

**12.4. Install the seeder mounting bracket to the front leg using two bolts.**

**Note:** Use a third bolt to loosely attach the **seeder mount clamp** to the **seeder mounting bracket**.

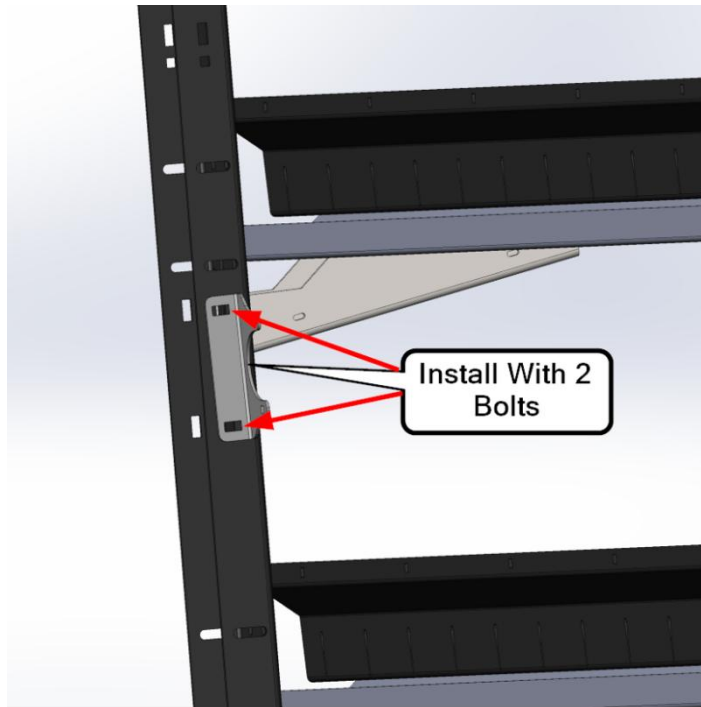

**12.5. The seeder assembly is ready to be installed.**

12.5.1. Place the auger end of the **seeder assembly** into the hole of the seed reservoir assembly.

12.5.2. Place the motor end of the seeder assembly into the **seeder mounting bracket** and secure the **seeder mount clamp** using two bolts.

**12.6. After the seeder assembly is installed, adjust the assembly to the measurements shown below.**

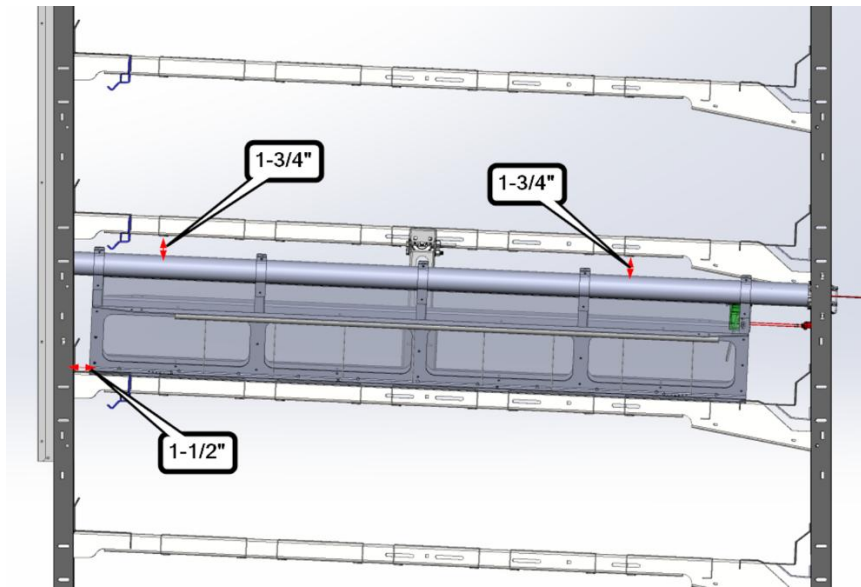

12.6.1. Once the assembly is aligned, tighten all the bolts.

12.6.2. Install the **seeder clamps** so that the assembly does not come out of alignment.

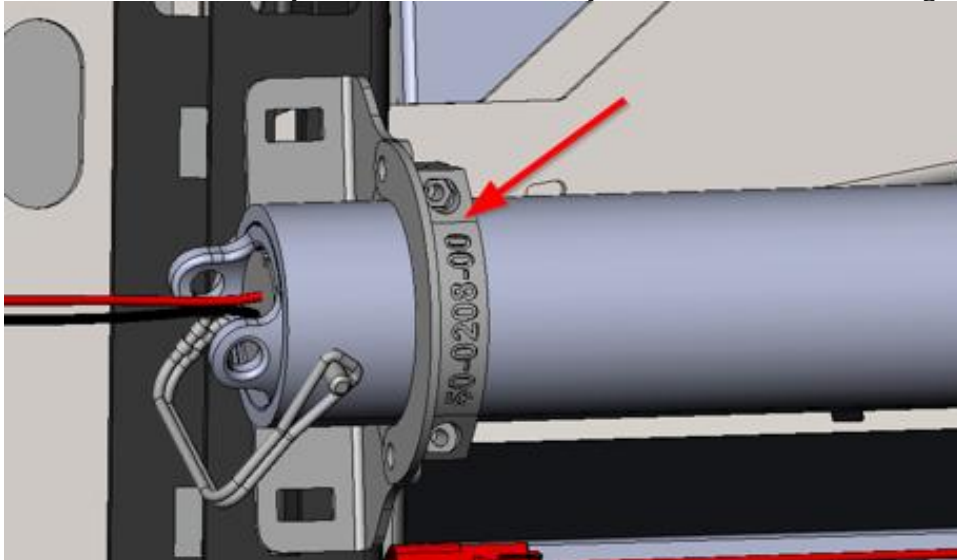

12.6.3. Attach the **seeder rake** to the outlet of the **seeder assembly**.

**Note:** Use the 2<sup>nd</sup> hole from outside on the top rows to mount the seeder rake.

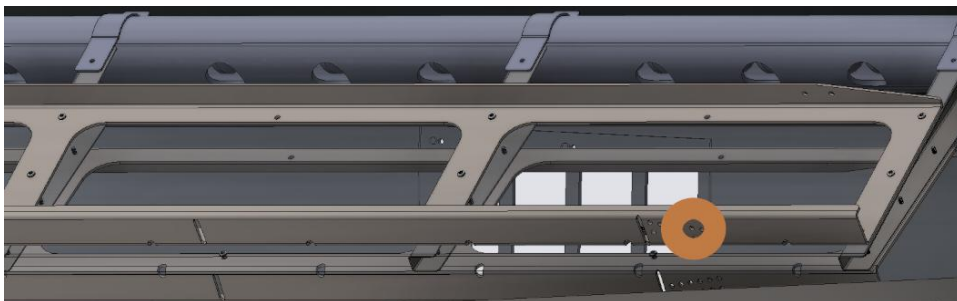

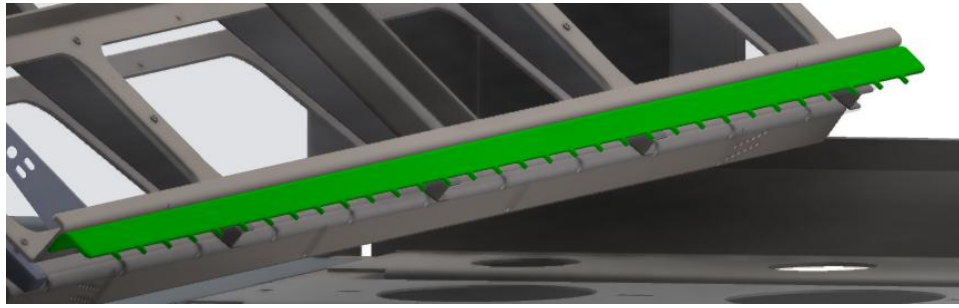

**12.7. Install the seeder assembly onto the lift cylinder assembly.**

12.7.1. Unscrew the seeder lifting slide from the seeder assembly.

12.7.2. Slide the rollers of the seeder lift cylinder arm into the seeder lifting slide.

12.7.3. With the rollers in the slide, replace the **seeder lifting slide** onto the **seeder assembly**.

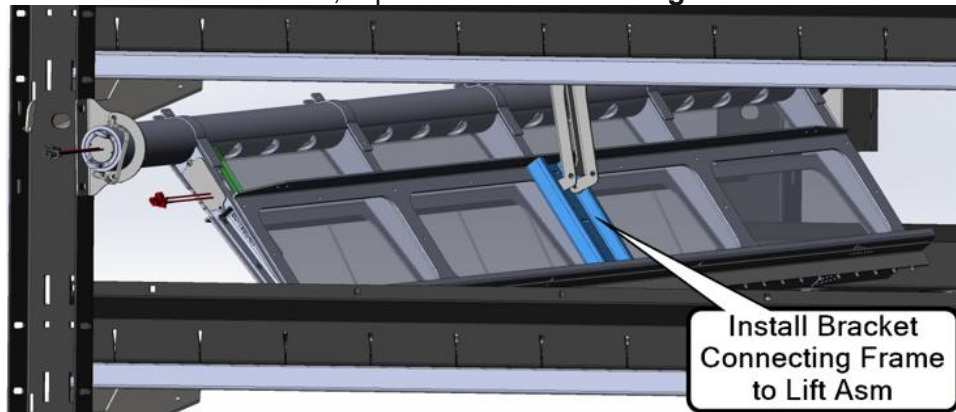

**12.1. Run air lines to the seeder lift assembly.**

12.1.1. Run two air lines from the **lift cylinder** to the low side of the table.

12.1.2. **Note:** Air lines can be run along the inside of the **cross brace** so that they are not hanging down and are hidden.

12.1.3. Loosely secure the lines by using zip ties.

12.1.4. Install air regulators on the **top supports** of the machine, front and back, on the low side as shown below.

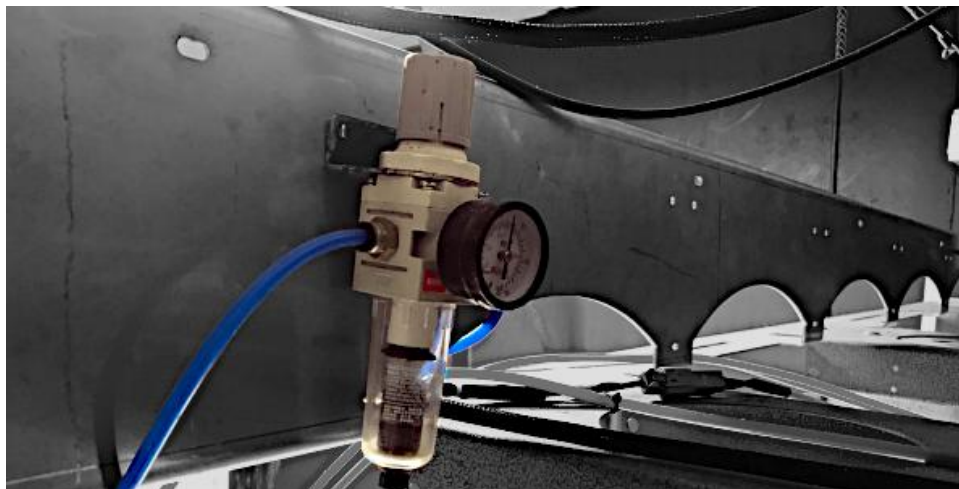

- 1.5.1.1. Plug the air supply line into the inlet of the front air regulator.
- 1.5.1.2. Plug an outlet line into the outlet of the **air regulator**.
- 1.5.1.3. Plug the end of the outlet line into a **T** fitting.
- 1.5.1.4. Run one line out of the **T** down the low side of the table taking care to zip tie and hide the line.
- 12.1.5. Run another line out of the **T** to the rear of the table using zip ties to secure/hide the line.

# 13. Drain Pans

Qty	Part #	Description	Pallet
1	30-0017	Kit, Consumables	11
30	51-2170	Drain Pan	6
6	39-0268	Drain Pan Weldment Center Slope	9

## 13.1. Prepare the drain pans for installation and tape the seams.

**Note:** Start with levels 2-5.

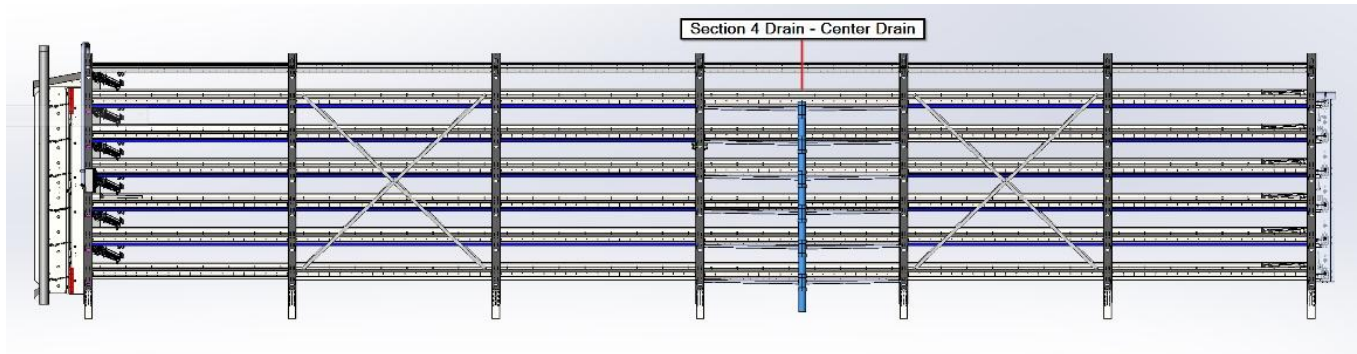

13.1.1. Lay out the drain pans upside down and end to end on the level that they will be installed.

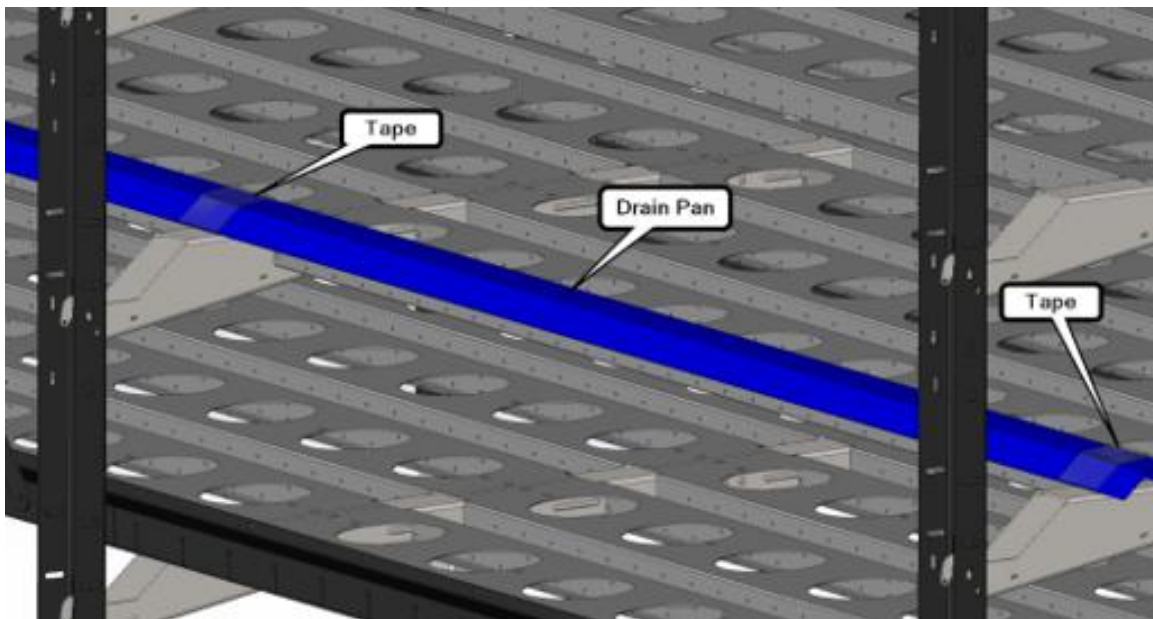

13.1.2. Clean off approximately three inches of the end surface of the **drain pans** using solvent and a rag.

13.1.3. Butt the **drain pans** against each other and use flex tape to tape the **drain pans** together.  
**Note:** The tape should cover the width of the **drain pans** so that no water can seep out when the **drain pans** are flipped into place.

## 13.2. Use four people spaced out evenly to flip the drain pans into place.

**Note:** The **drain pans** sit in a groove on the **cross brace**. Take care to ensure that the seams of the **drain pans** stay in the middle of the legs and that the mounting holes on the **drain pans** line up with the holes on the legs.

**13.3. Loosely attach the drain pans to the legs using bolts until all drain pans are in place on levels 2-5.**

**13.4. Install lower side plates.**

**Note:** The **lower side plates** should sit flat on the **cross brace** and sit flush against the inner leg. Failure to ensure the proper alignment of the plates will cause **belt** issues during machine operation.

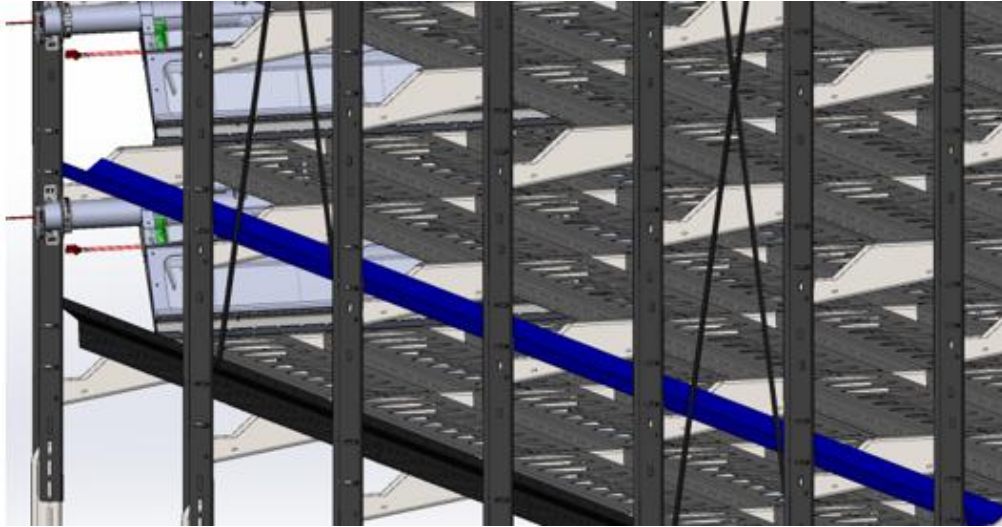

**13.5. Remove lower side plates on levels 1 & 6.**

**13.6. Install the drain pans on these two levels.**

13.6.1. Adjust the pitch of the **drain pans** to create a slope towards the PVC drainpipe.

1.5.1.5. Start at the front **leg** and raise the **drain pan** to the top of the slot. Tighten the bolt and move to the next leg.

1.5.1.6. Continue to tighten the drain pan bolts at each leg so that the **drain pans** slope towards the drainpipe location.



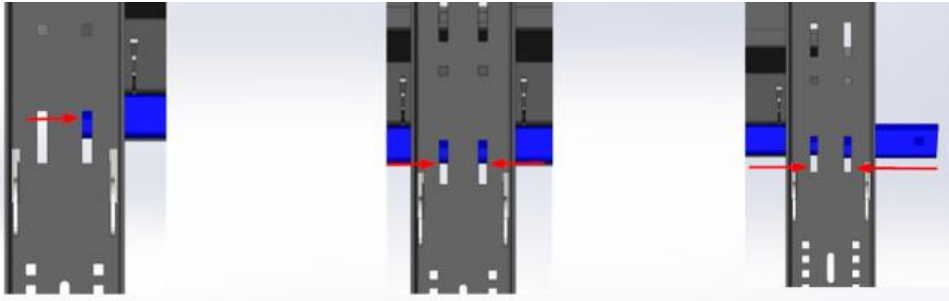
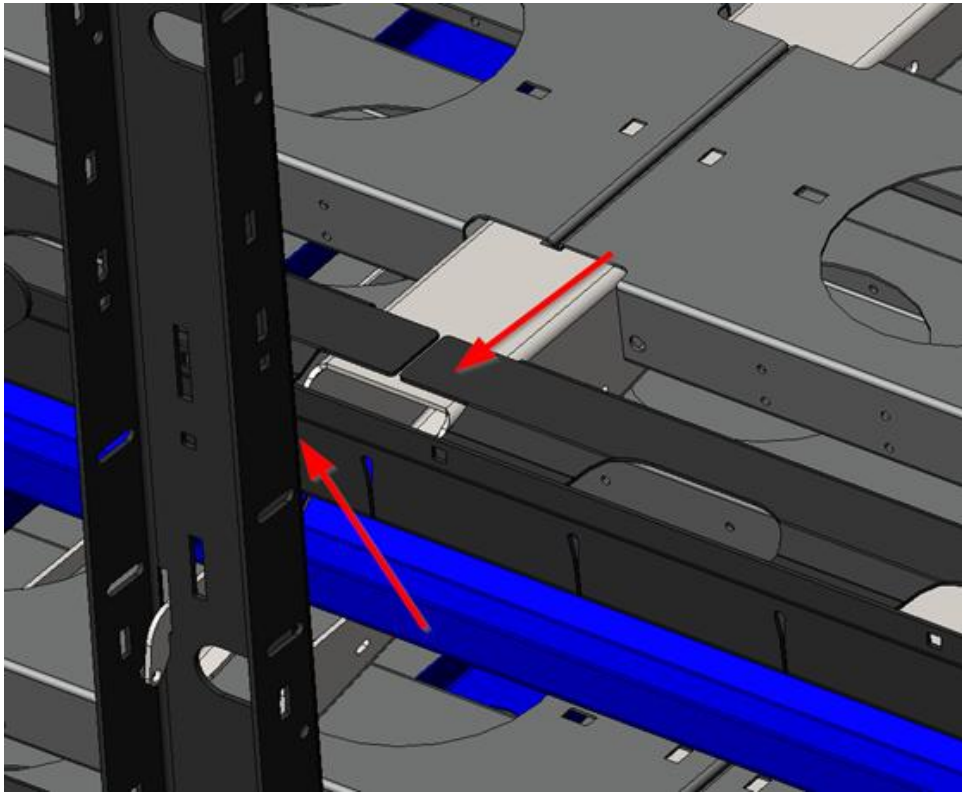

# 14. Unload Chute & Drive Shaft Assembly

Qty	Part #	Description	Pallet
1	30-0003	Kit, Clutch Front	1
1	30-0006	Kit, Belt Cleaning & Disinfectant Booms	1
2	51-2016	Unload Side Plate	10
6	39-0332	Axel	1
6	51-1830	Unload Chute	10

## 14.1. Install the unload side plates.

14.1.1. Start by using the alignment holes in the unload side plates and secure with a bolt, loosely tightened.

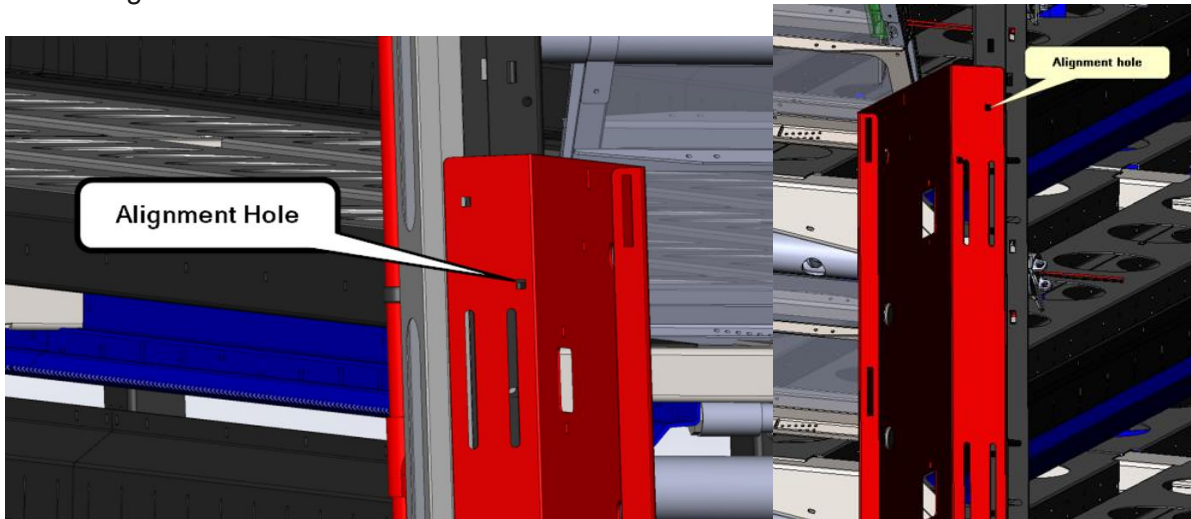

14.1.2. Once the side plate holes are aligned to the legs, put loosely tightened bolts into the slotted holes.

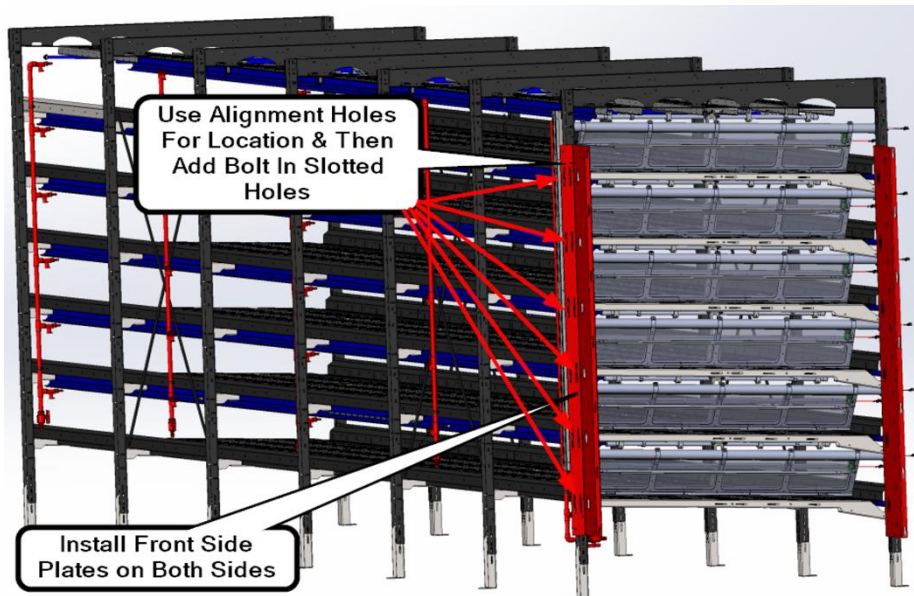

14.2. Install the drive shafts.



14.2.1. Take the drive shafts and slide them through the drive shaft holes on the unload side plates.

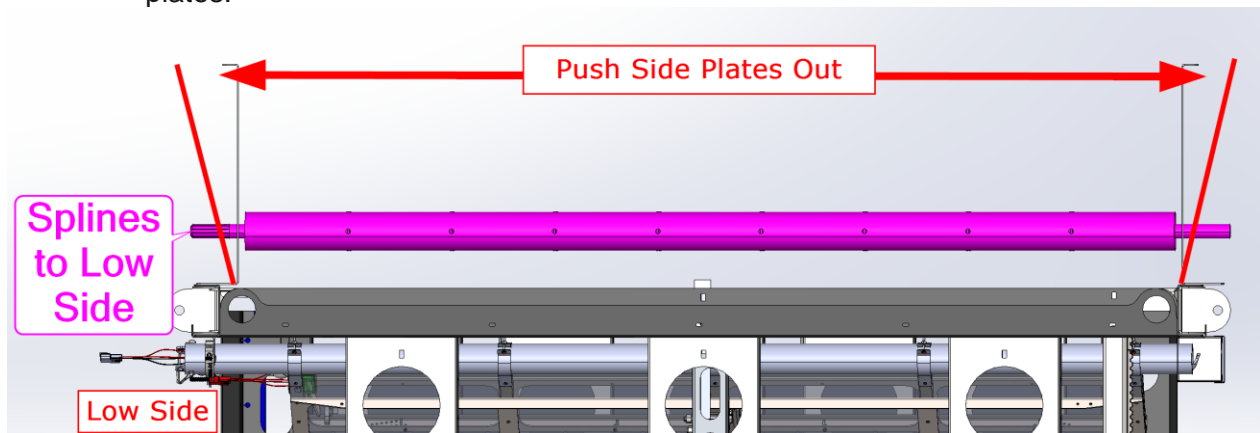

14.2.2. Place the alignment washers on the shaft ends of the drive shaft and slide them to the square part of the shaft.

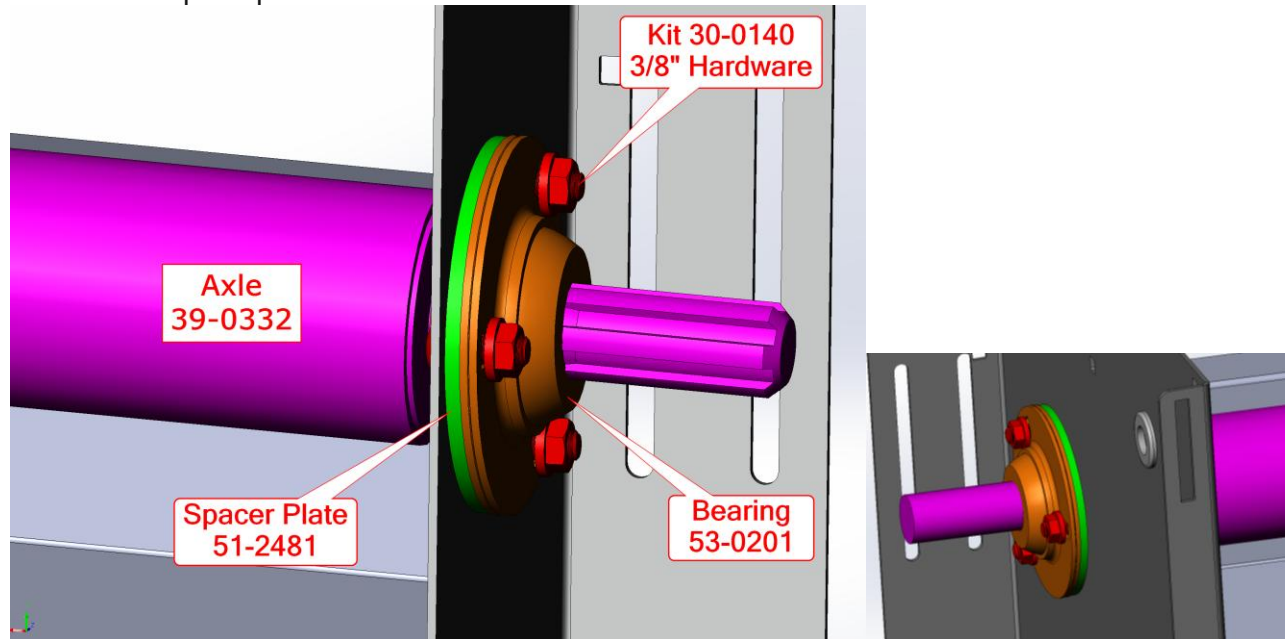

### 14.3. Assemble the unload chutes.

14.3.1. Install 3 jack nuts on the front of the chute.

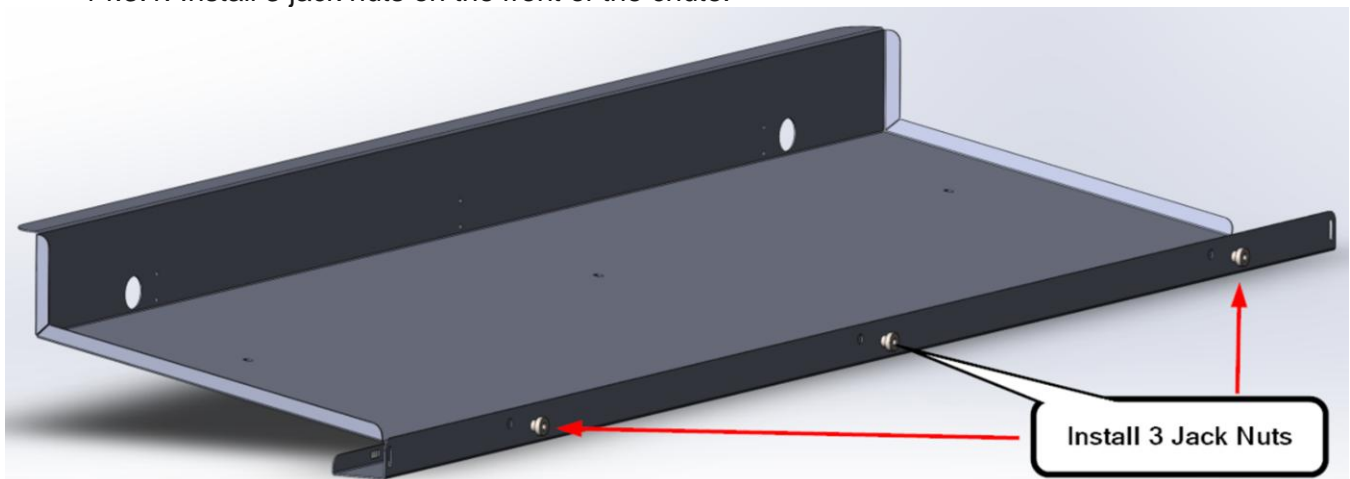

14.3.2. Lay out the plumbing pieces on the chute as shown.

14.3.3. Press fit the hose barb on to the belt cleaning spray boom pipe high side and the plug on the low side. The high side hole of the chute will get a rubber grommet that the hose barb fits through, and the low side hole will get a rubber grommet blank.

**Note:** Lubrication on the inside of the grommet reduces friction.

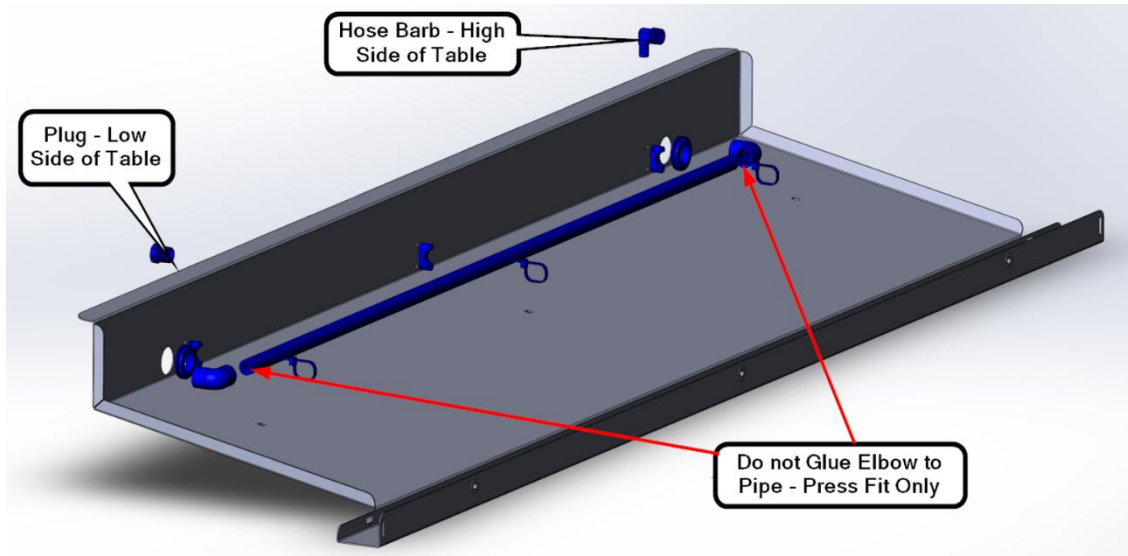

14.3.4. Adjust the holes on the belt cleaning spray boom pipe at a 45° angle. The final adjustment of these holes will need to be made when water is running through the pipe.

- ✓ The spray holes are orientated upwards as shown below.
- ✓ The elbow points to the **high side**.

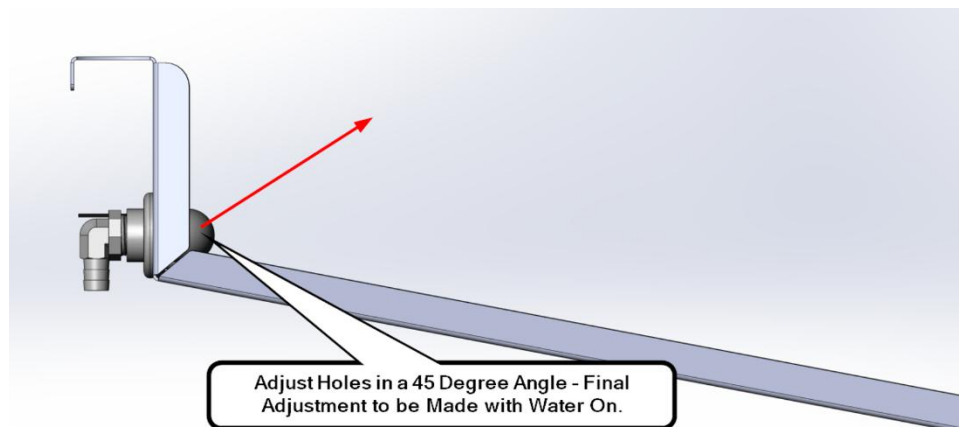

14.3.5. Secure the **belt cleaning spray boom** pipe onto the chute.

**Note:** Zip-tie the **belt cleaning spray boom** to the **pipe mounting bracket** and through holes on the **unload chute**.

14.3.6. Install the threaded hose barb onto the belt cleaning spray boom on the high side.

14.3.7. Attach the hose onto the **hose barb** and leave the other end hang for now.

**Note:** You can set the assembly to the side and assemble the remaining unload chutes or install them as you go.

**14.4. Hook the back of the unload chute drain pans into the cross brace.**

**Note:** Drain pans hook into the slots on the **cross braces** and overlap the **chute drains**.

**14.5. Install the unload chute drains.**

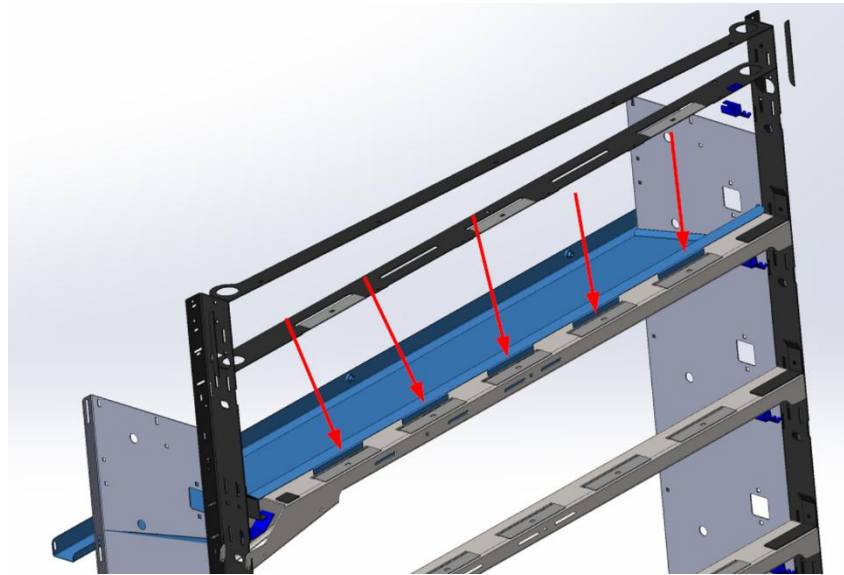
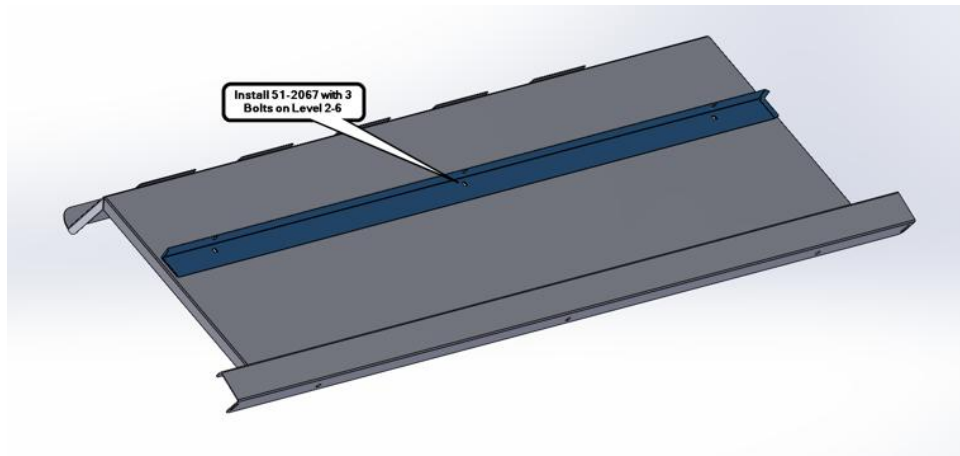

#### 14.6. Install the unload chute drain pans.

- ✓ Drain pans are firmly seated and hang over the front chute drains.

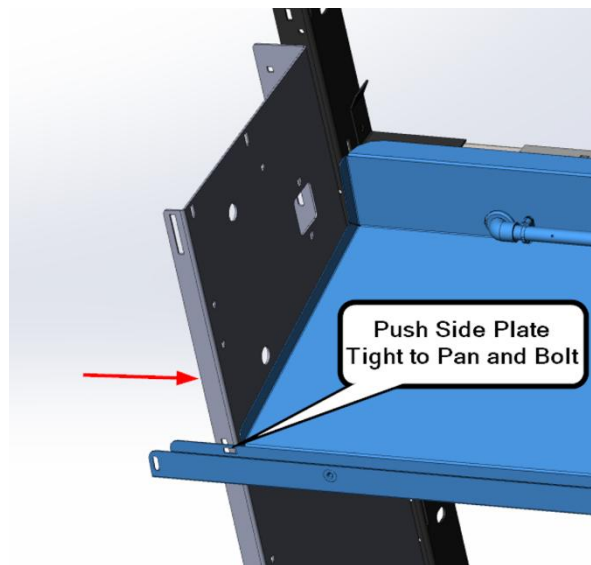

# 15. Harvest Motor & Jaw Clutch

Qty	Part #	Description	Pallet
1	30-0003	Kit, Clutch Front	1
2	30-0014	Kit, Motor Drive	1
1	30-0172	Box, Small Parts DGS 66	1
1	51-1832	Front Motor Mount	10

## 15.1. Harvest motor and jaw clutch assembly

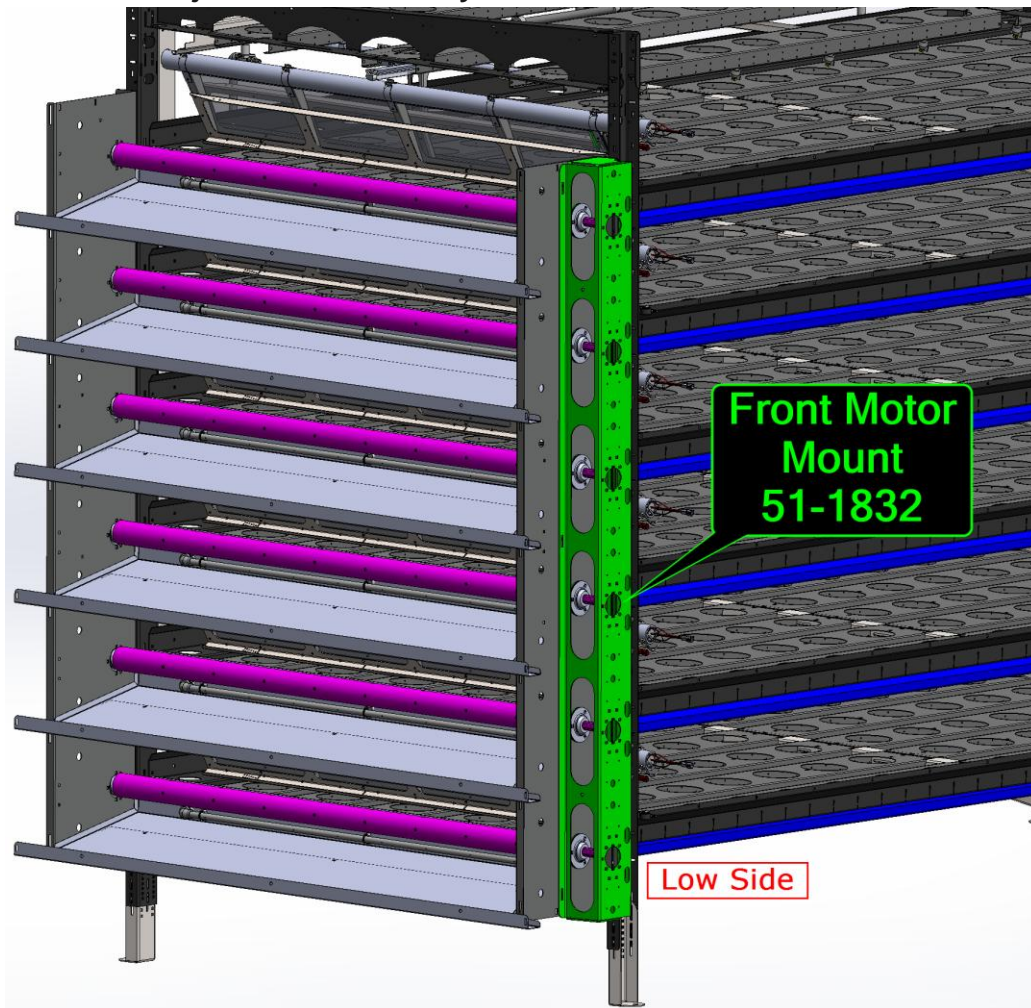

- 15.1.1. Start by installing the motor mount to the unload side plate on the drain side of the table. Hand-tighten the bolts so that adjustments can be made after the jaw clutch assembly is installed.
- 15.1.2. Slide the jaw clutch slide jaw onto the drive shaft. The jaw clutch slide jaw should slide easily on the drive shaft.

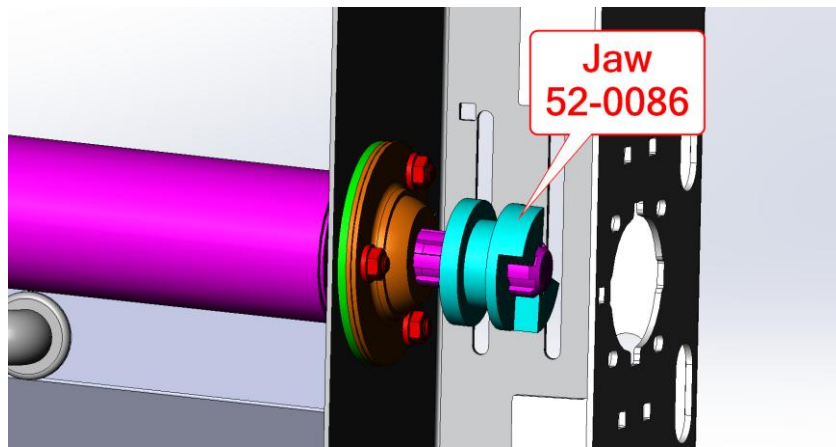

## 15.2. Install the harvest motor.

15.2.1. First, place 4 washers onto the shaft of the motor. The key can then be slid into the keyway of the motor.

15.2.2. Place the motor shim onto the bolts of the motor with the thicker side facing toward the top of the table. The motor can then be mounted onto the motor mount.

**Note:** As the motor is being positioned into the mount, line up the **jaw clutch driving jaw** in place on the **inside** of the mount so that as the motor is slides into place, the shaft of the motor slides onto the **jaw clutch driving jaw**.

15.2.3. Secure the motor to the mount with four 5/16" flange nuts. Tighten the jaw clutch driving jaw onto the motor shaft using 3, 1/4"-20 x 1" and 1, 1/4"-20 x 3/4" hex bolts.

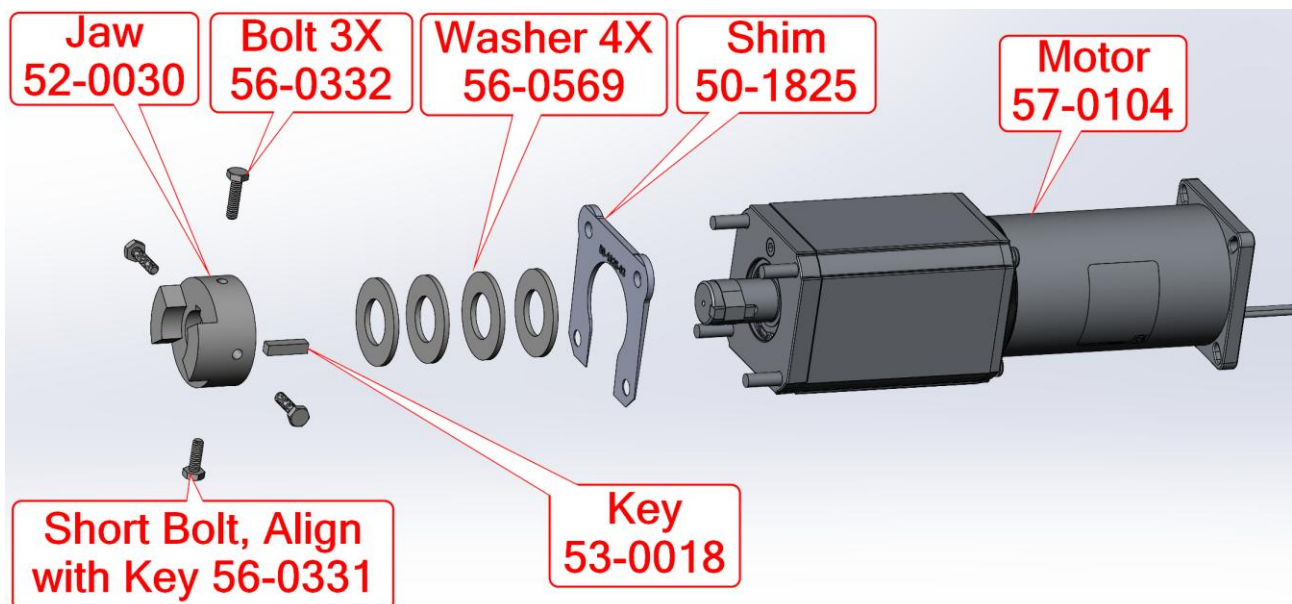

15.2.4. Install motors on all levels.

### 15.3. Install Pneumatic Clutch

15.3.1. Install the air cylinder to the motor mount. Use supplied wrench (51-2378)

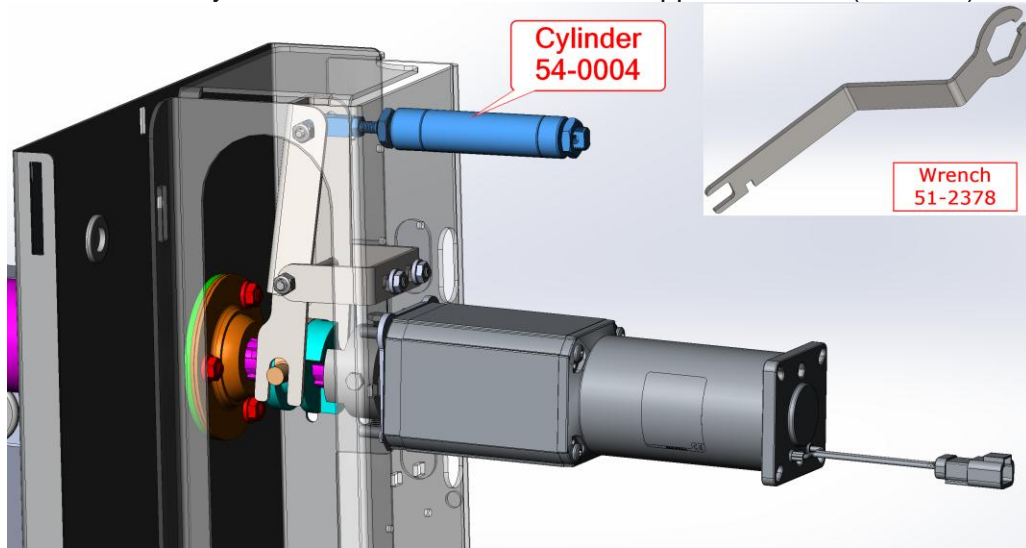

15.3.2. Take the shaft ends of the jaw clutch yolk and slide them into the slots of the jaw clutch pivot arm. Hold these two pieces together as jaw clutch yolk is placed onto the jaw clutch slide jaw. Attach the jaw clutch pivot arm to the motor mount using 2 bolts.

15.3.3. Run a  $\frac{1}{4}$ "-20 x 2  $\frac{1}{2}$ " through the top of the jaw clutch pivot arm and through the yolk of the air cylinder. Use a nylon lock nut and tighten until the nut is locked on but not touching the jaw clutch pivot arm.

15.3.4. Align the jaw clutch driving jaw and the jaw clutch slide jaw by adjusting the motor mount. Once the jaws are aligned, ensure easy movement of the jaw clutch slide jaw by moving it in and out on the drive shaft. Tighten the bolts on the motor mount.

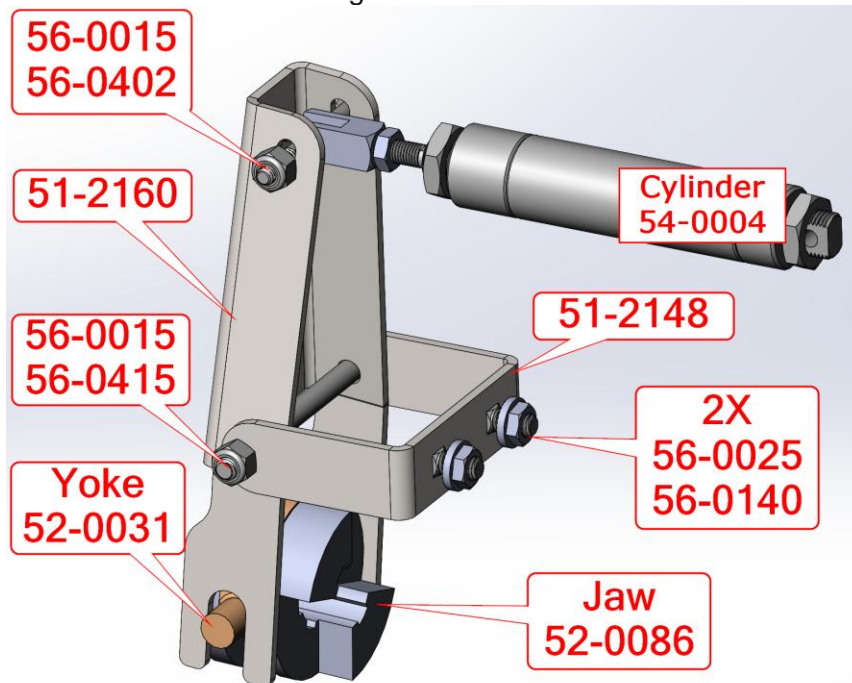

# 16. Hydraulic Sizer

16.1. Remove the two 5/16" bolts from the mounting plate on each side of the sizer assembly.

16.2. Install the hydraulic sizer by inserting it between the unload side plates.

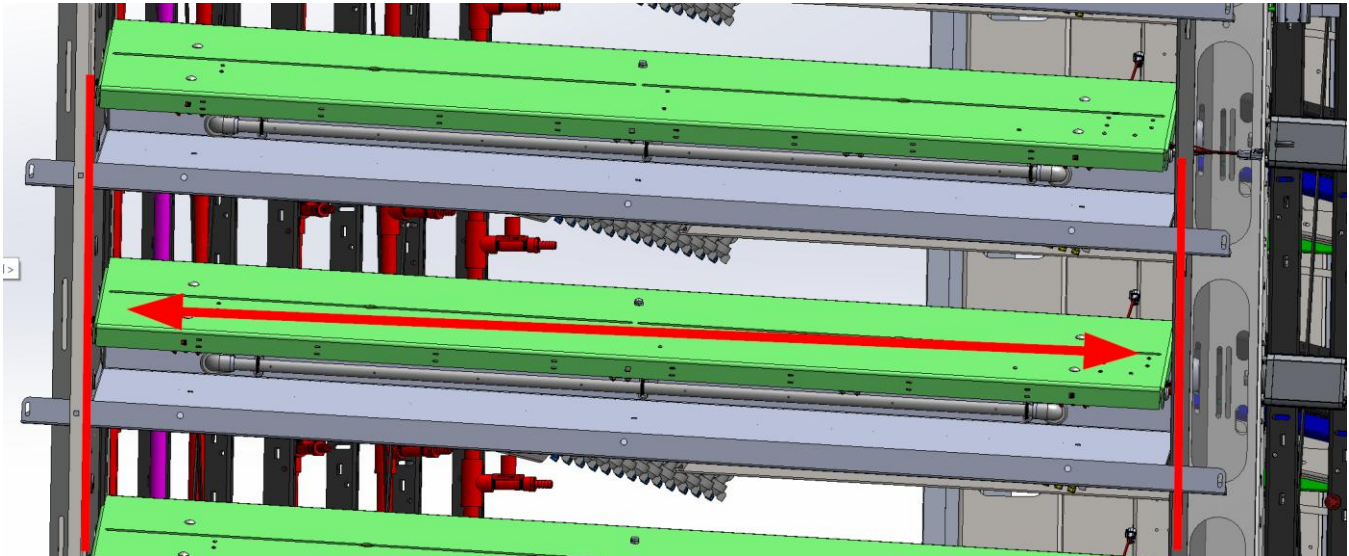

16.3. The hydraulic sizer will fit over the top of the drive shaft. Secure the sizers by using 2 bolts.

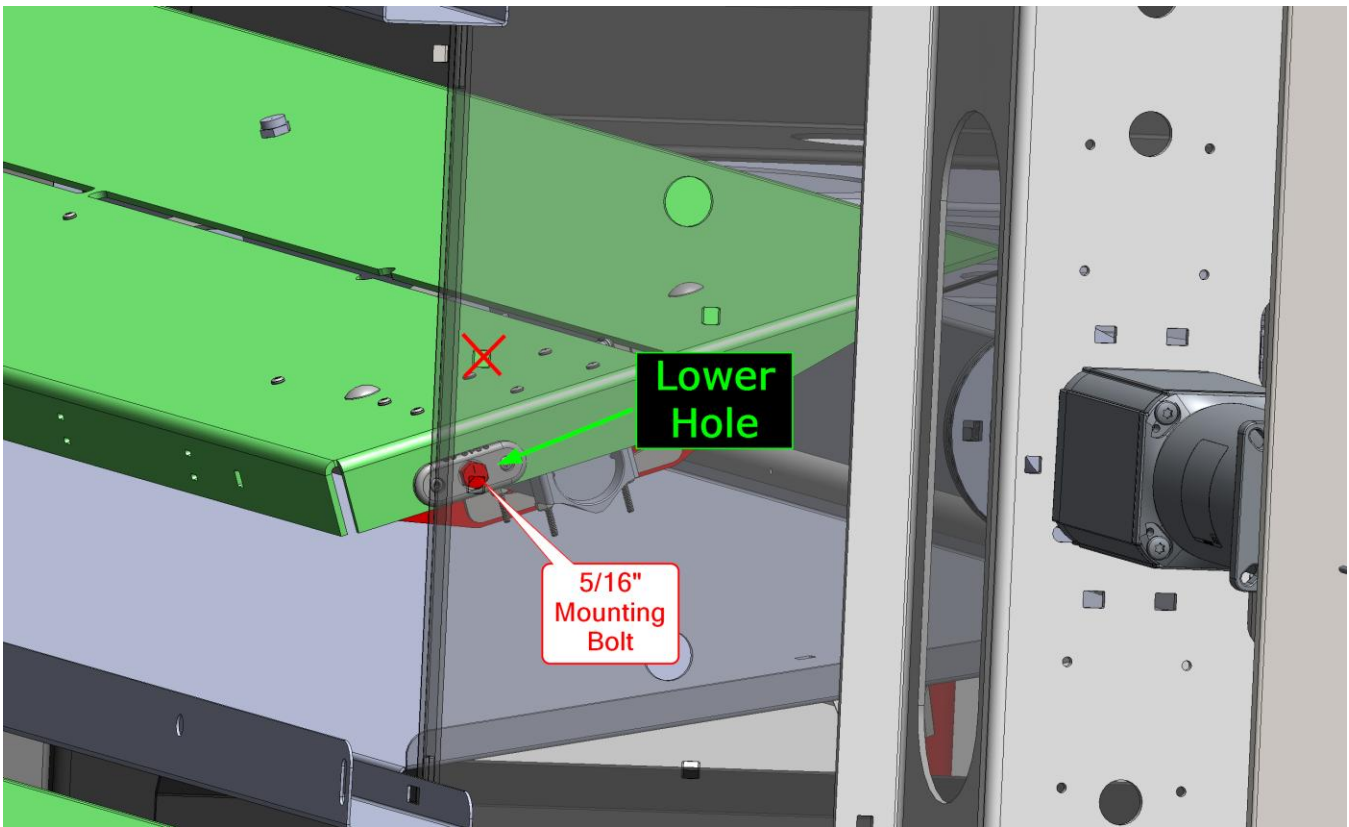

16.4. Secure with the two 5/16" bolts snug allowing the sizer to pivot on the bolts.

# 17. Pull Back Assembly Installation

Qty	Part #	Description	Pallet
1	30-0016	Kit, Clutch Rear	1
2	30-0014	Kit, Motor Drive	1
1	30-0081	Kit, Pull Back Spindles	11
1	51-1974	Clutch Mounting Bracket	?
1	51-2005	Rear Spray Shield	10
1	51-1956	Pull Back Motor Mount	10

## 17.1. Clutch mounting bracket.

17.1.1. Install the clutch mounting bracket by inserting a bolt into the alignment hole on the cross brace.

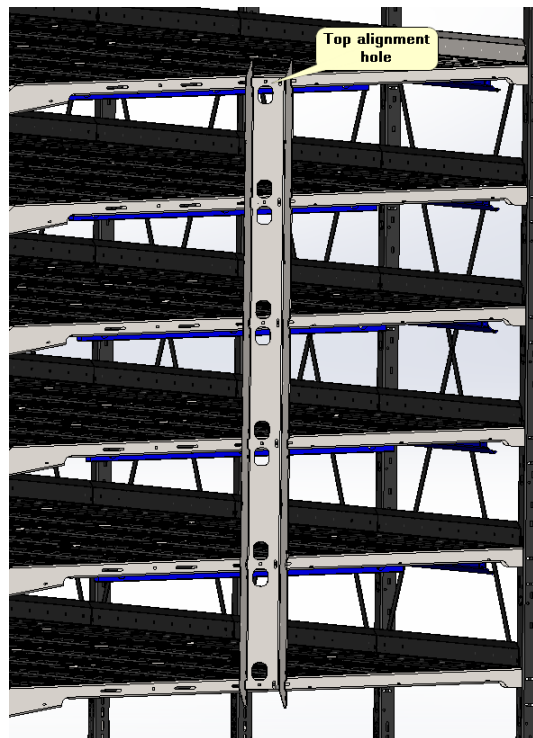

17.1.2. Insert 2 bolts through the slotted holes at the bottom of the clutch mounting bracket and through the slotted holes of the cross brace.

17.1.3. Ensure that the clutch mounting bracket is level by putting a level on the side of the bracket. Once level, tighten the bolts and install. Then, tighten bolts on the other levels.

**17.2. Install the rear spray shield by bolting it onto the low side of the clutch mounting bracket.**

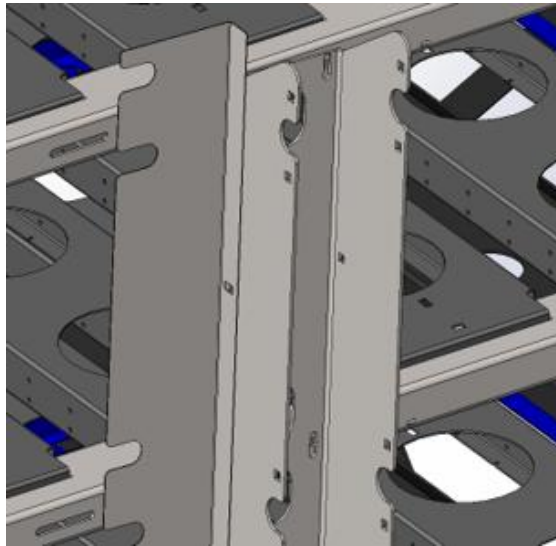

### 17.3. Pull back motor mount.



17.3.1. Install the pull back motor mount by inserting a bolt into the alignment hole on the cross brace.

17.3.2. Insert bolts through the slotted holes at the bottom of the pull back motor mount and through the slotted holes of the cross brace. Hand tighten the bolts.

### 17.4. Clutch pack.

17.4.1. Set the pull back spool weldment into the notch of the clutch mounting bracket.

17.4.2. Slide a lock collar onto the shaft of both ends of the weldment.

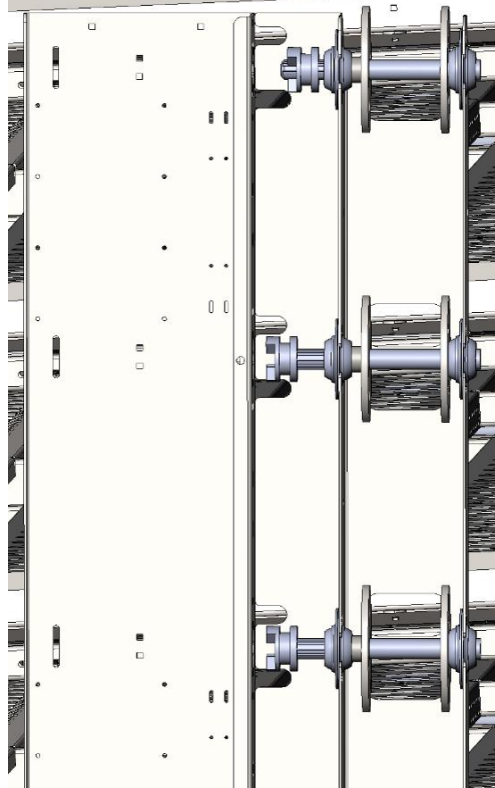

17.4.3. Slide on a bushing onto the shaft of both ends of the weldment.

17.4.4. Slide the jaw clutch slide jaw onto the shaft of the weldment shaft facing the drain side of the table.

17.4.5. Ensure that the spool plates of the pull back spool weldment is centered on the large hole of the clutch mounting bracket. Tighten down the set screws of the lock collar.

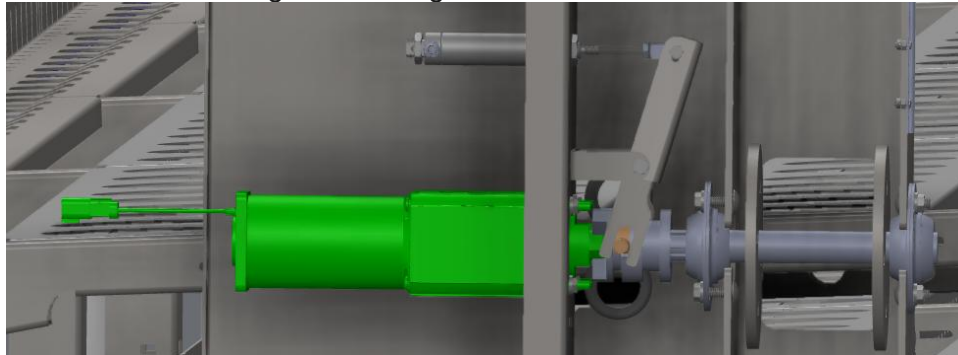

17.4.6. Install the jaw clutch assemblies like the steps in 15.3.

**Note:** Use four washers between the clutch drive jaw and the motor housing to prevent the drive jaw from slipping backwards towards the motor housing.

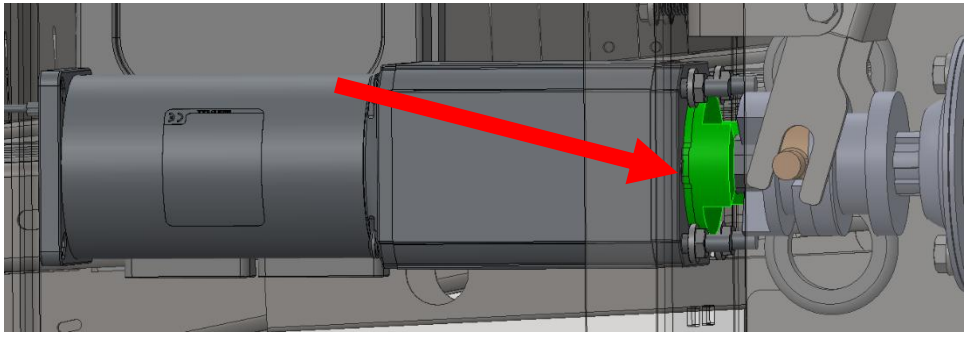

# 18. Belts

Qty	Part #	Description	Pallet
6	39-0343	Belts	11
1	79-0003	Tape, Gorilla, Black, 3"	1

## 18.1. Install the belts.

18.1.1. Feed the first belt (pull back bars first) into each level from the front of the machine as it unrolls.

18.1.2. Attach the rope from the **pull back spool** to the **pull back bar** on the **belt assembly**.

18.1.3. From the middle section of the machine, pull the rest of the belt in over itself until the end of the belt is flush with the drive shaft.

**Note:** Take care when running the harvest motor for the first time to prevent the extra belt from catching on spray nozzles as the slack pulls out of the belt.

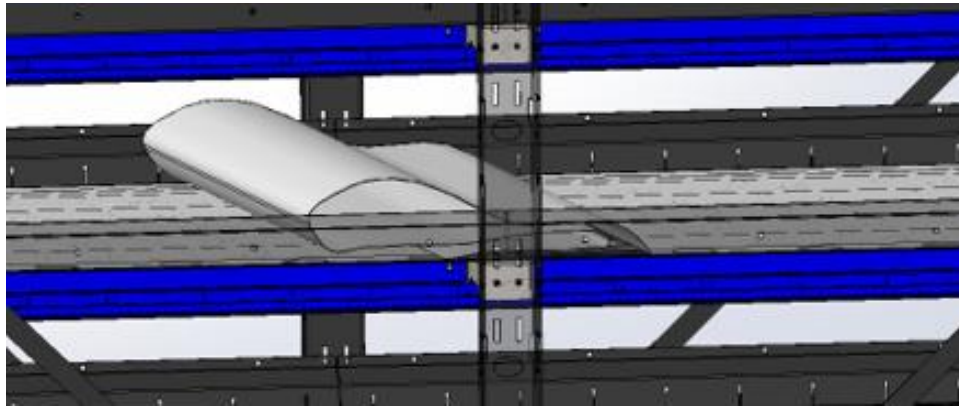

## 18.2. Tape the belt onto the drive axle.

**Note:** There should be  $\frac{1}{4}$ " gap between the **belt** edge and the **belt support top** inside edge and the **belt** should be square with the **drive axle**.

18.2.1. Clean the **drive axle**.

**Note:** Use solvents to remove any oil or grime.

18.2.2. Tape the top side of the **belt** onto the **drive axle** as shown below.

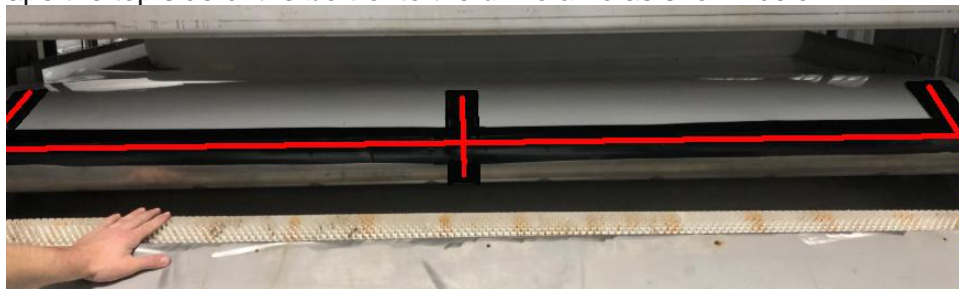

18.2.3. Tape the bottom side of the belt onto the **drive axle**.

**Note:** Rotate the drive shaft in reverse to expose the bottom seam.

18.2.4. Continue the process of installing **belts** on the remaining levels.

### 18.3. Belt clean off.

18.3.1. Install the belt clean off to the pull back top bar using two bolts as shown in Figure 76.

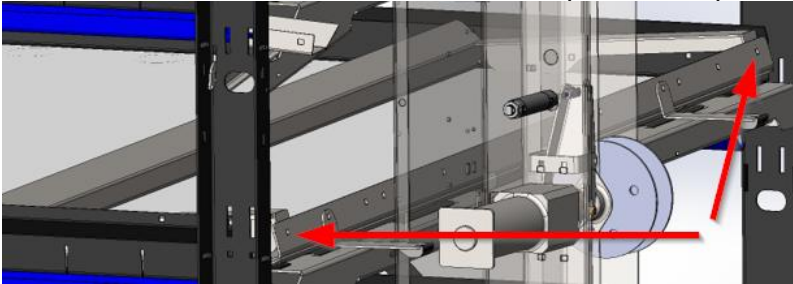

18.3.2. Install the push off bar guide to the pull back top bar.

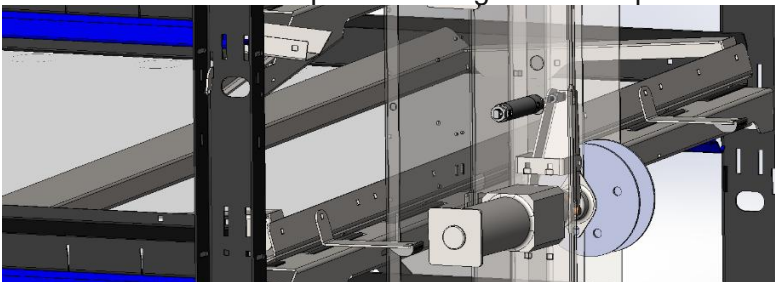

18.3.3. Connect the pull back spool to the pull back bottom bar using the quick-link through the holed tab on the pull back spool assembly.

# 19. Spray Boom Drive Assembly

Qty	Part #	Description	Pallet
1	30-0008	Kit, Spray Boom Drive	1

## 19.1. Install spray boom drive arm assembly.

**Note: DO NOT** over tighten the nylon lock nut on the assembly. This could put too much pressure on the bushing, crushing it, and causing the system to fail.



19.1.1. While assembling the Hub assembly verify the hardware is installed in the correct hole. They are labeled with an 8 for a GLS 808 or a 6 for a DGS 66.

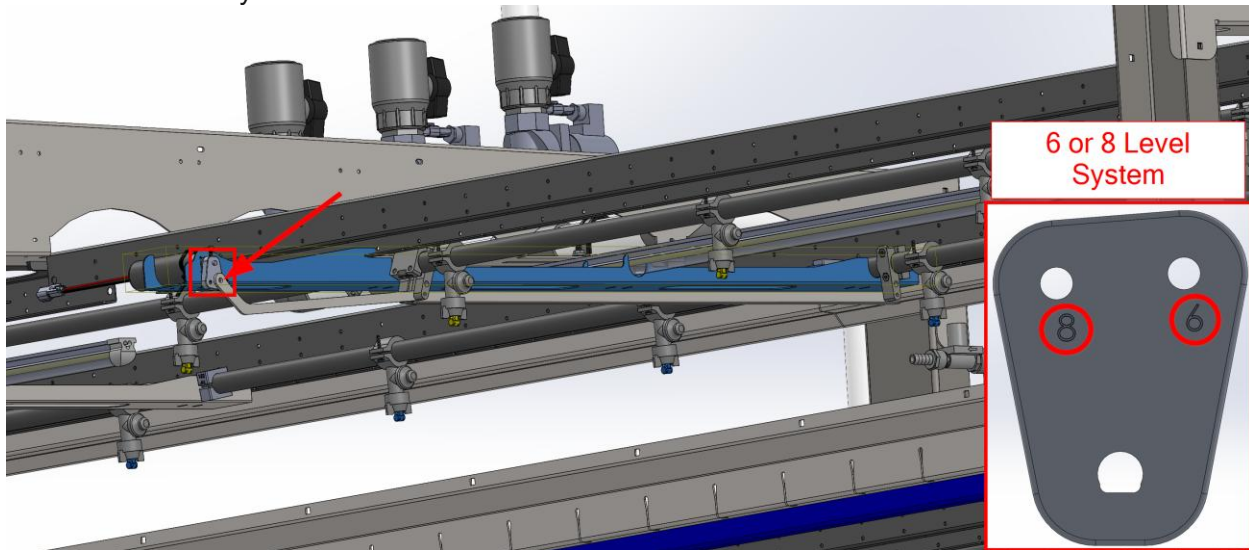

19.1.2. Install the spray boom drive clamps onto the yellow tipped spray boom.

**Note:** Loosely attach the **spray boom clamp drive cap** and the spray boom clamp drive end together using four 1½” machine screws.

19.1.3. Install the **spray boom idle clamps** like the previous step using two machine screws.

19.1.4. Install the watering arm and the sprayer cross brace.

19.1.5. Loosely install two **water pipe clamp** caps around each boom on the opposite side of the **spray boom motor mount** from the **spray boom idle clamp** and **spray boom drive clamp**.

**Note:** Sandwich the spray boom motor mounts between the clamps to prevent the boom from sliding.

✓ Clamps are in place to prevent spray boom lateral movement.

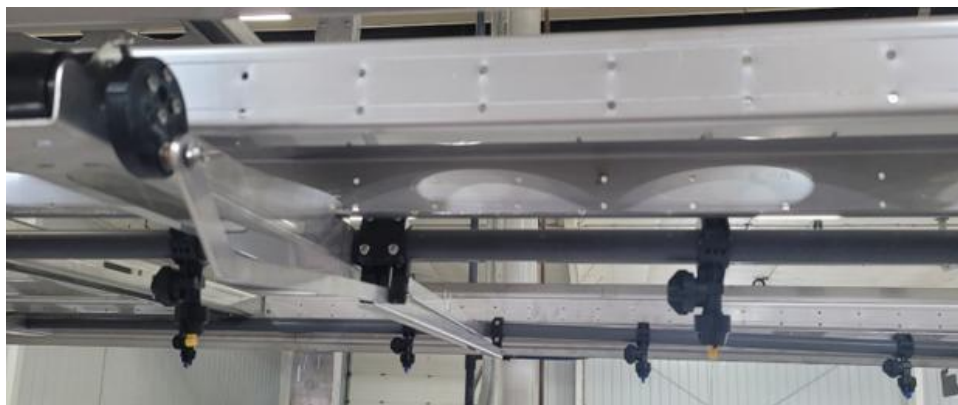
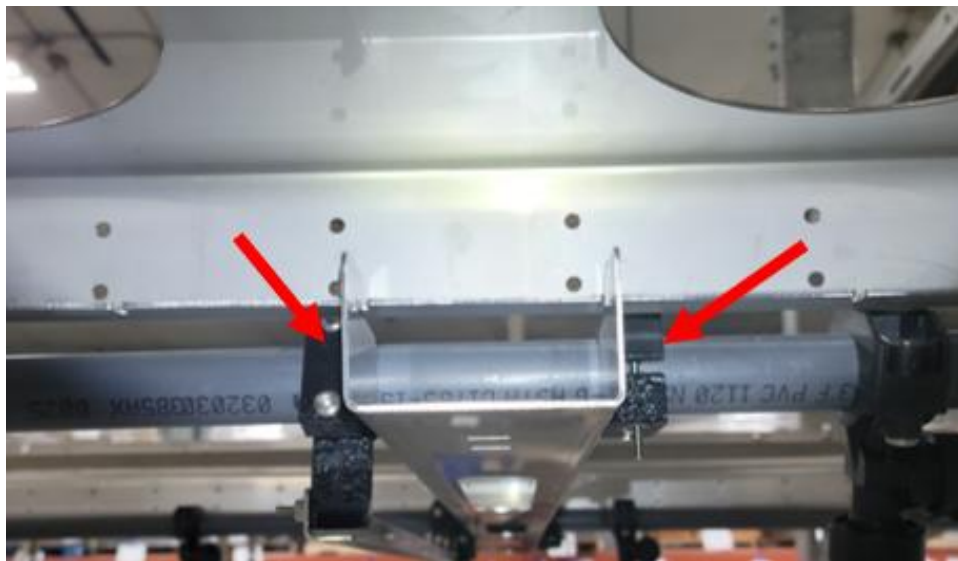

## 20. Hydraulic Sizer Manifold

Qty	Part #	Description	Pallet
1	30-0011	Kit, Cutter Manifold	1

- 20.1. Bolt the hydraulic sizer manifold mounting bracket to the high side unload side plate.
- 20.2. Slip the rubber grommets into the holes on the high side unload side plate and slip the blind rubber grommets into the low side unload side plate.
- 20.3. Attach the hydraulic sizer hose manifold to the mounting bracket using U-bolts.
- 20.4. Feed the hose from the hydraulic sizer through a rubber grommet and screw the end into the manifold.
- 20.5. Attach the pressure washer feed hose into the top of the manifold feed pipe.
- 20.6. Repeat these steps for all levels.



# 21. Front Nodes & Air Solenoids

Qty	Part #	Description	Pallet
1	30-0002	Kit, Pneumatics Front	1
1	30-0502	Kit, Nodes	15

## 21.1. Install front nodes (3)

**Note:** Each **node** and **air solenoid** manifold controls two levels of the table. The top node and **air solenoids** will control levels 5 & 6. The next node down controls levels 3 & 4 and the bottom **node** that controls levels 1 & 2.

**Note:** Nodes and Air Solenoids can be mount to shield on sawhorse or once the shield is mounted to the machine

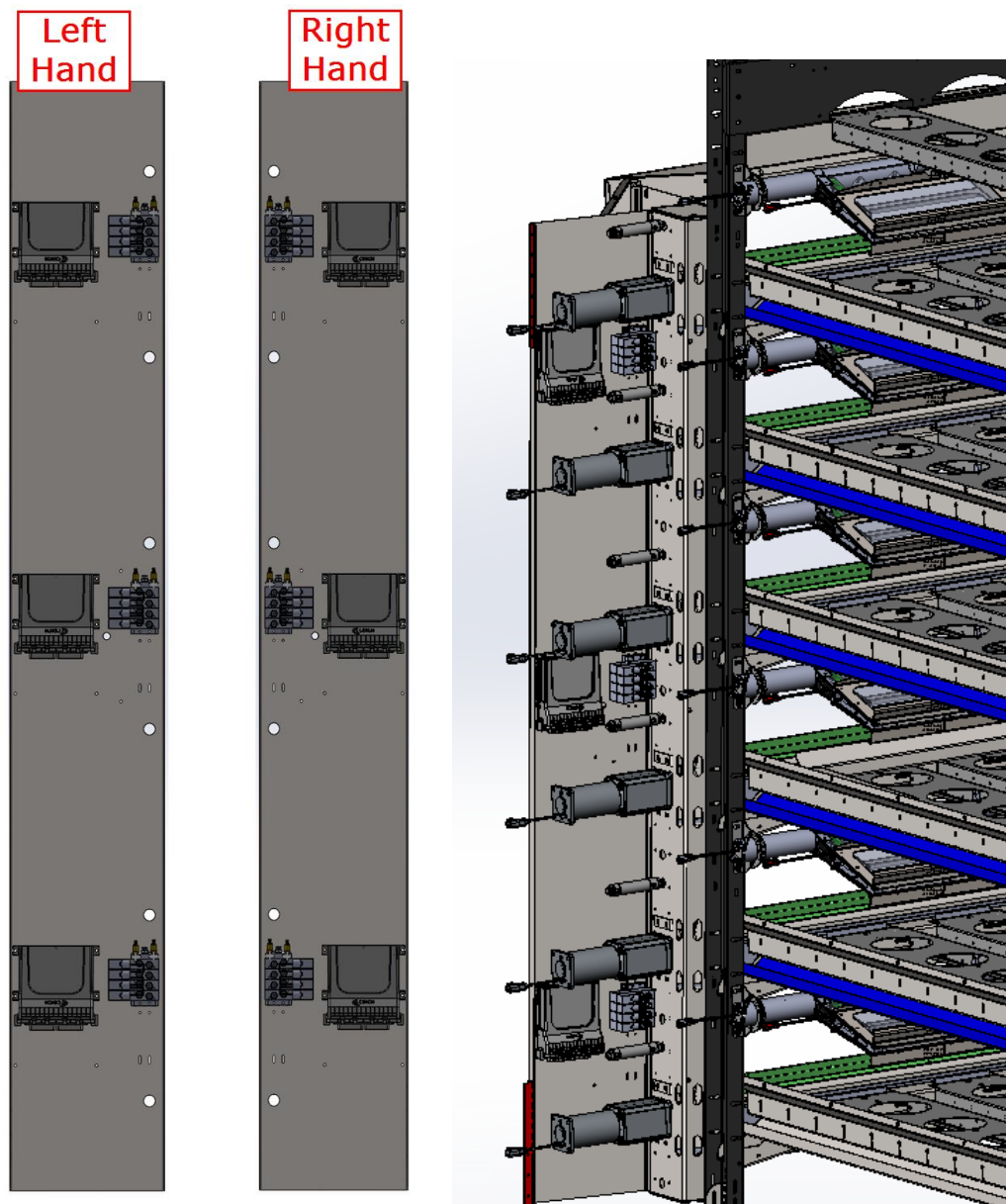

21.1.1. Fasten the nodes onto the front drive motor shield using hardware kit 30-0150 #10 machine screws and nylon lock nuts.

21.1.2. Fasten the air solenoids to the front drive motor shield using hardware kit 30-0124 #6 machine screws and nylon lock nuts.

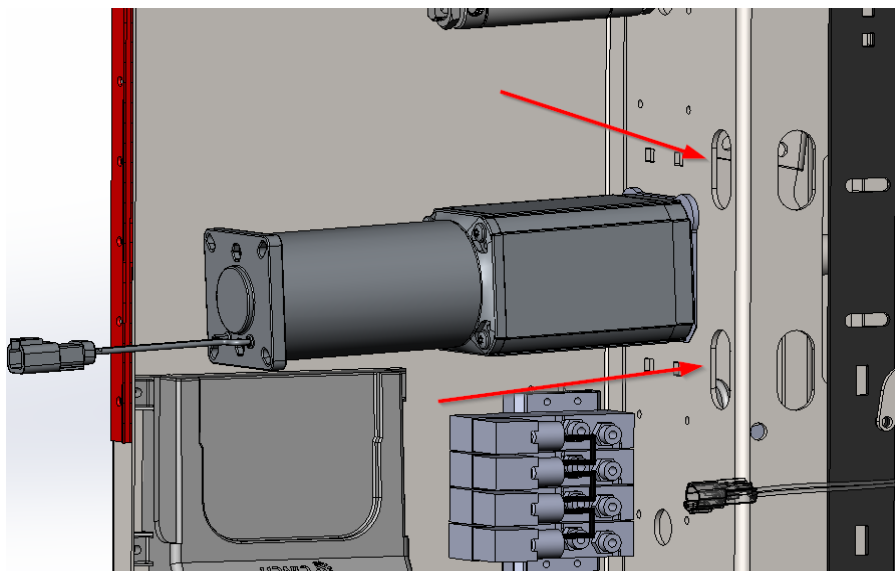
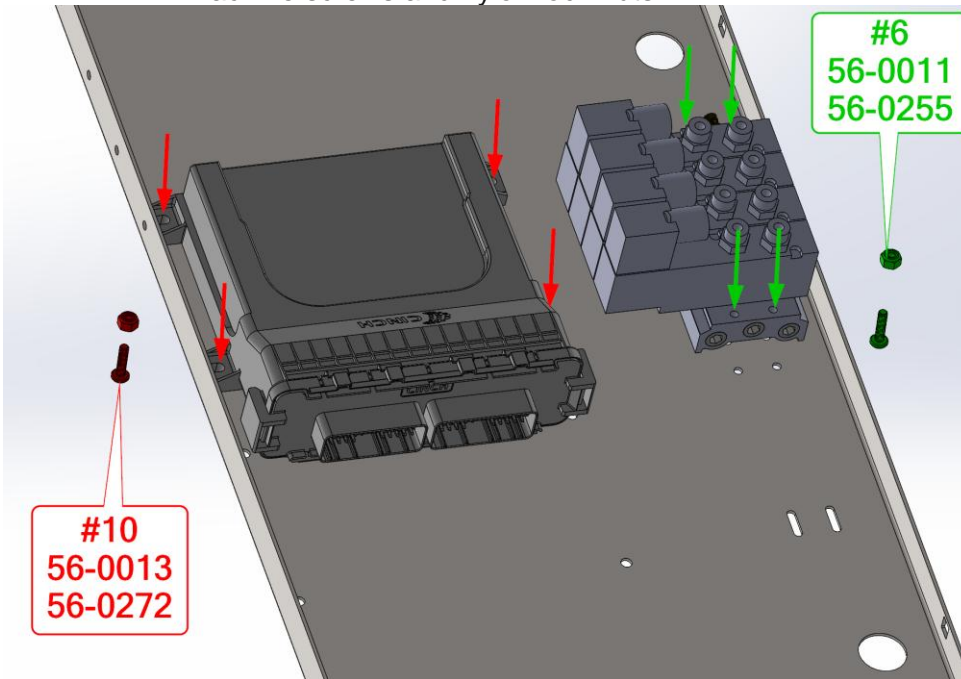

## 22. Front Air Line

Qty	Part #	Description	Pallet
1	30-0002	Kit, Pneumatics Front	1

Note: Do not install any zip ties until all plumbing and wiring is complete.

## 22.1. Run air lines to the front solenoid blocks.

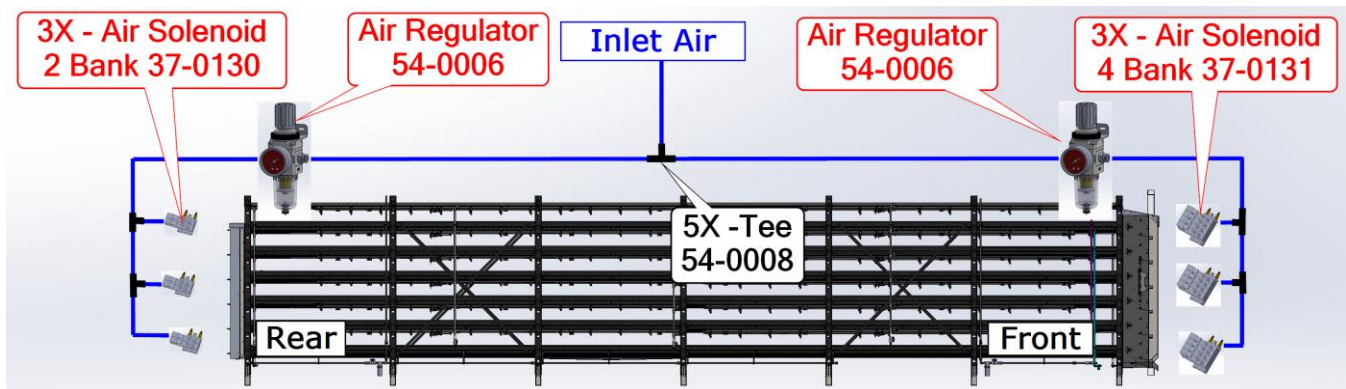

22.1.1. From the **T** at the **air regulator**, run an air-line down next to the inlet of the **top air solenoid** and insert the line into a **T** fitting.

**Note:** Run the line through holes and try to zip tie them out of sight.

22.1.2. Connect one line from the second **T** in the previous step to the inlet of the **top air solenoid**.

22.1.3. Run another line out of the remaining **T** port down to the next **air solenoid** and repeat the process of daisy chaining all three **air solenoid** inlets together with **T** fittings.

22.1.4. Run air lines from each **air solenoid** on the air manifold to each **seeder assembly and jaw clutch air cylinder**. Plug the upper-level air cylinder into the top solenoid. The outside air line will plug into the **B** inlet of the air solenoid and the inner line will plug into the **A** inlet. The seeder assembly air cylinder rear facing air-line will plug into the **B** inlet of the second to top solenoid and the front facing air-line will plug into the **A** inlet.

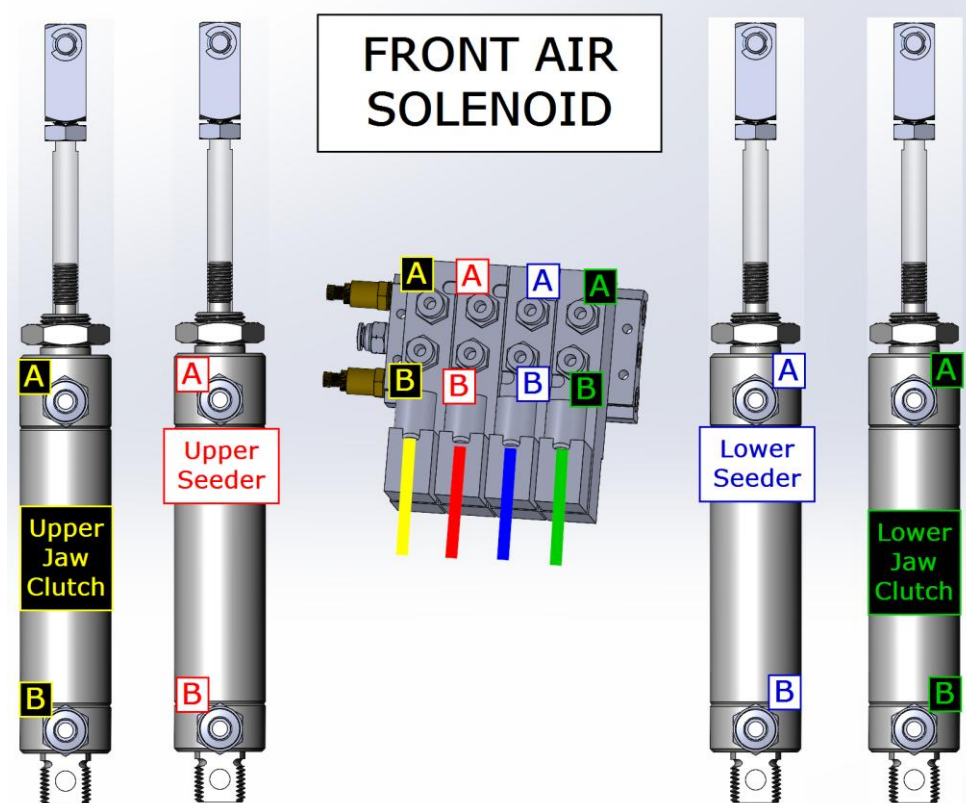

## 23. E-Stop

Qty	Part #	Description	Pallet
1	30-0514	Kit, Electrical Accessories	15

### 23.1. Install E-Stop 37-0133

**Note:** shipped with connector loose for install

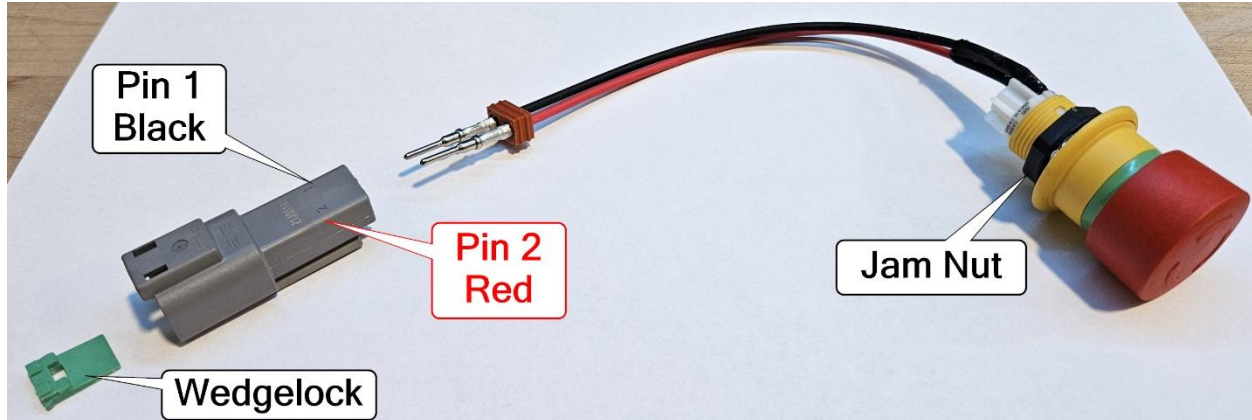
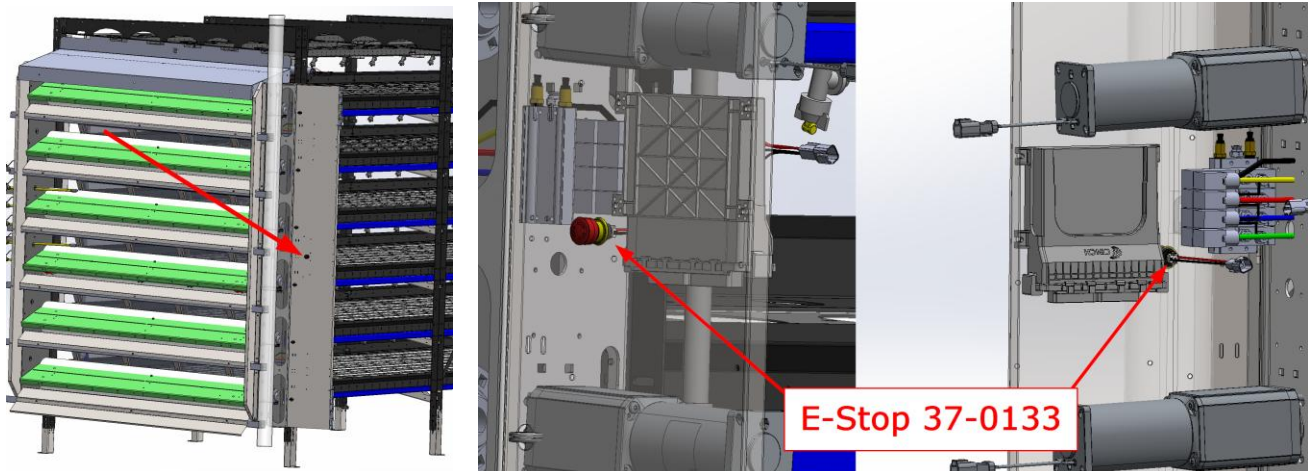

23.1.1. Insert the **E-stop** into the middle hole in the **front drive motor cover**.

**Note:** The **E-stop** ships unpinned from the connector to fit through the hole.

23.1.2. Pin the two wires onto the connector by sliding the pins into the receptacle and pushing until the pins are seated into the housing.

Pin	Wire Color
PIN 1	Black
PIN 2	Red

## 24. Rear Nodes & Air Solenoids

Qty	Part #	Description	Pallet
1	30-0004	Kit, Pneumatics Rear	1
1	30-0502	Kit, Nodes	15

24.1. Locate Node (57-0175) from control box and 2 bank air solenoid (37-0130) from kit 30-0004 Pallet #1.

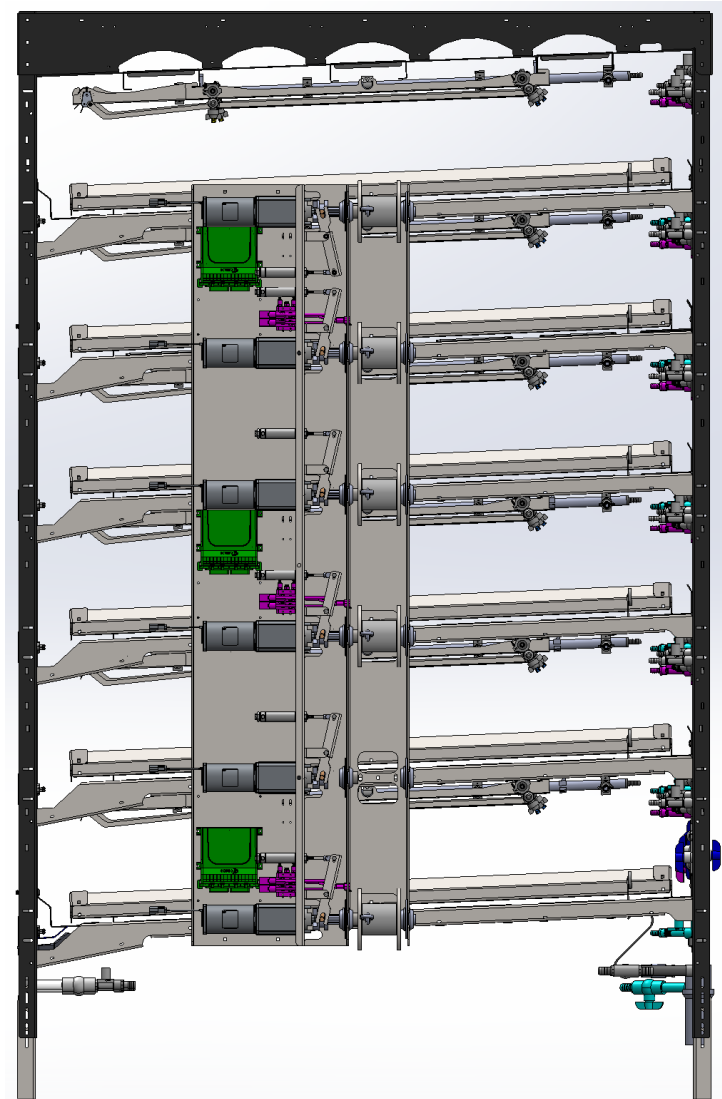

24.1.1. Fasten the nodes to the rear motor mount with #10 machine screw and lock nut from kit 30-0150

24.1.2. Fasten the 2 bank air solenoid to the rear motor mount with #6 machine screws and lock nut from kit 30-0124

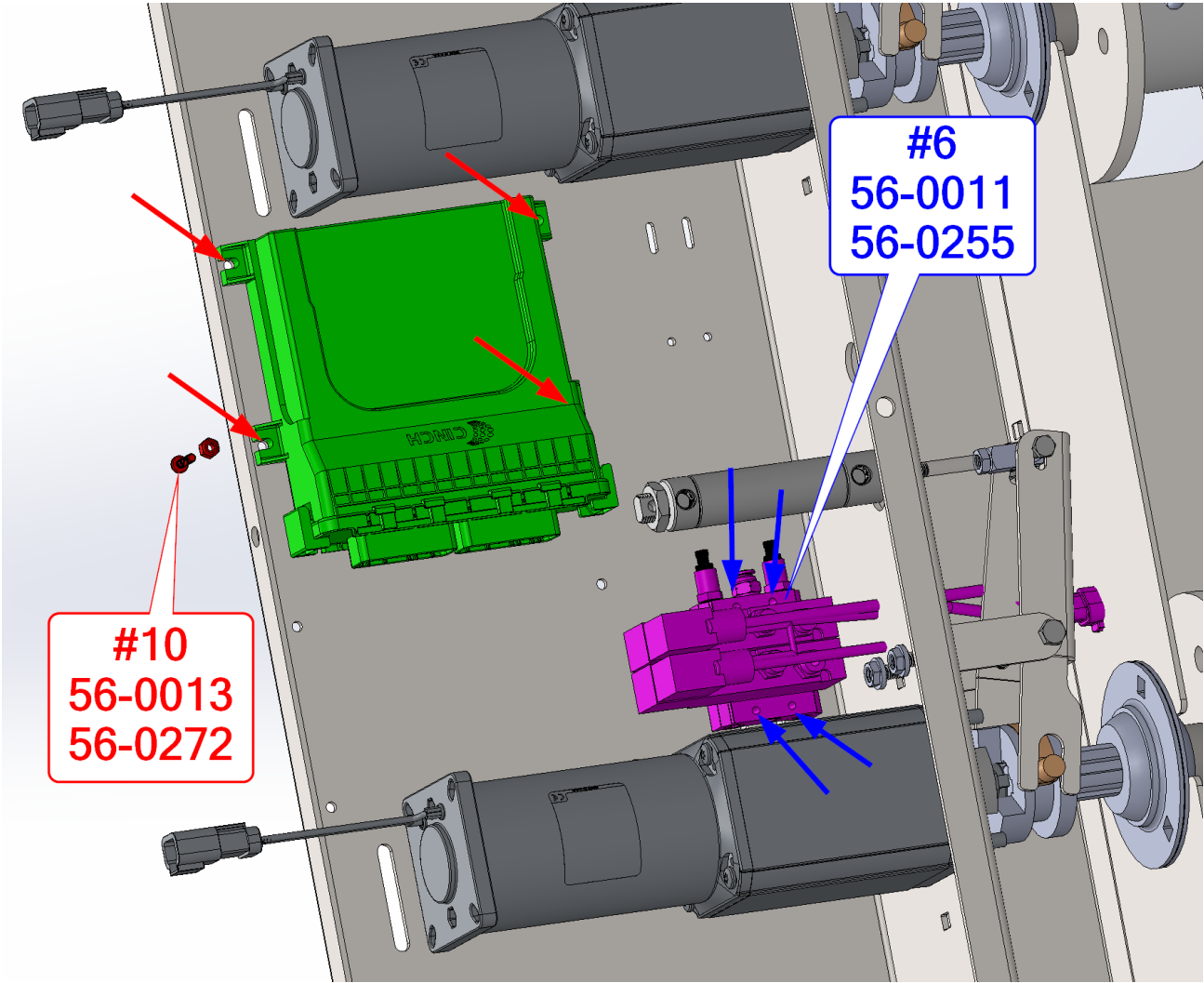

# 25. Rear Air Lines

Qty	Part #	Description	Pallet
1	30-0004	Kit, Pneumatics Rear	1

## 25.1. Run air lines to the rear solenoid blocks.

25.1.1. Daisy chain the rear **solenoid** inlets together from the rear **air regulator** using **T** fittings.

25.1.2. Run air lines from the **air solenoid** control ports to the appropriate clutch **air cylinders** as shown below.

**Note:** The bottom solenoid on each block ports to the appropriate (L) designated level (1, 3, 5) while the top solenoid on each block ports to the appropriate (U) designated level (2, 4, 6).

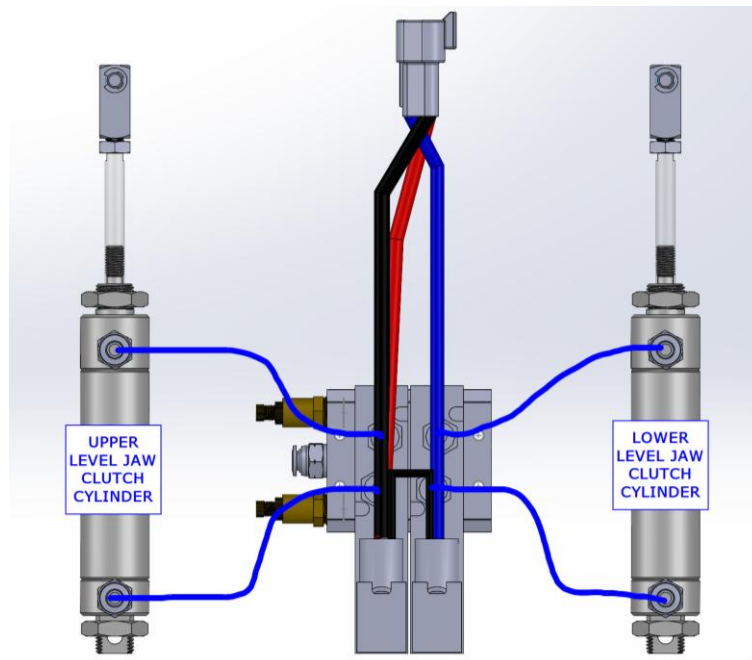

# 26. General Wiring Diagram

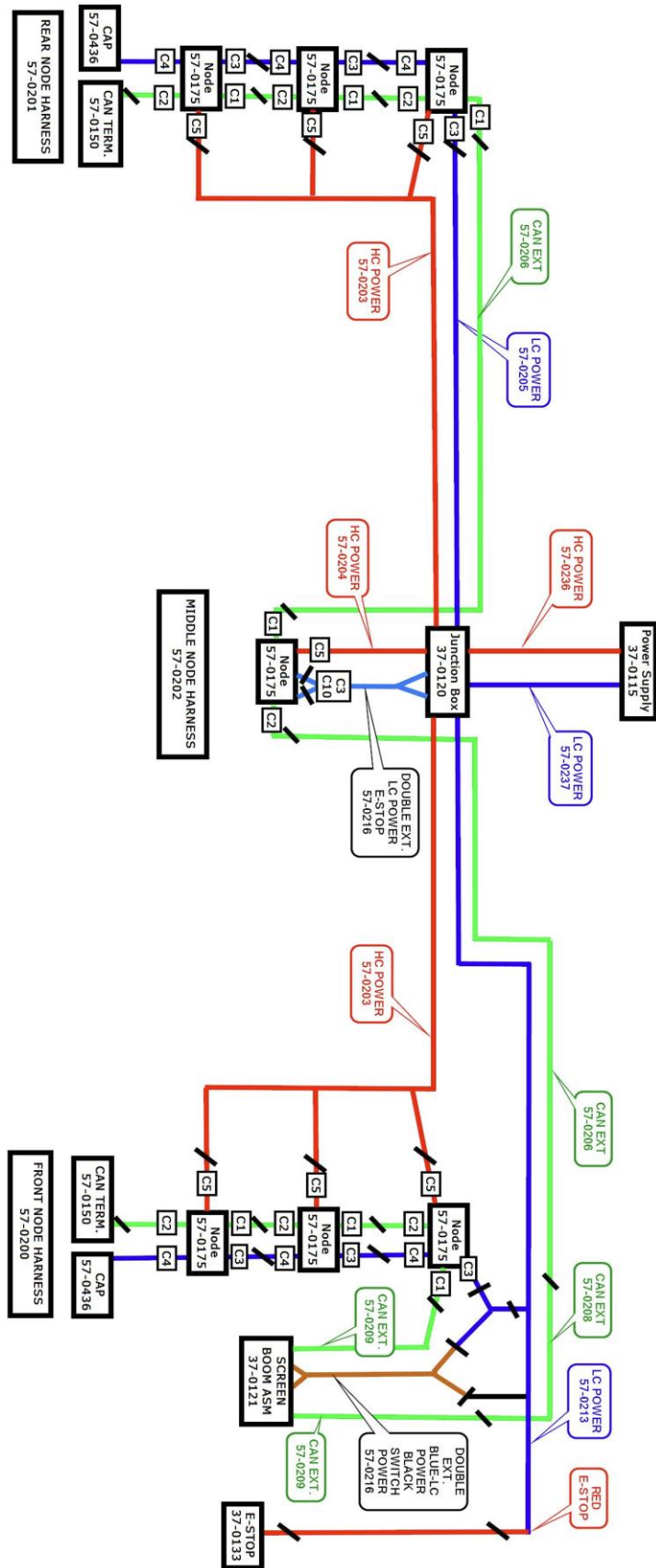

# 27. Front Node Harnesses

Qty	Part #	Description	Pallet
1	57-0200	Harness, Node, Front	15

**Note:** Don't zip tie any wires until all of the wiring is completely installed

## 27.1. Connect the front wiring harness (57-0200) to the node.

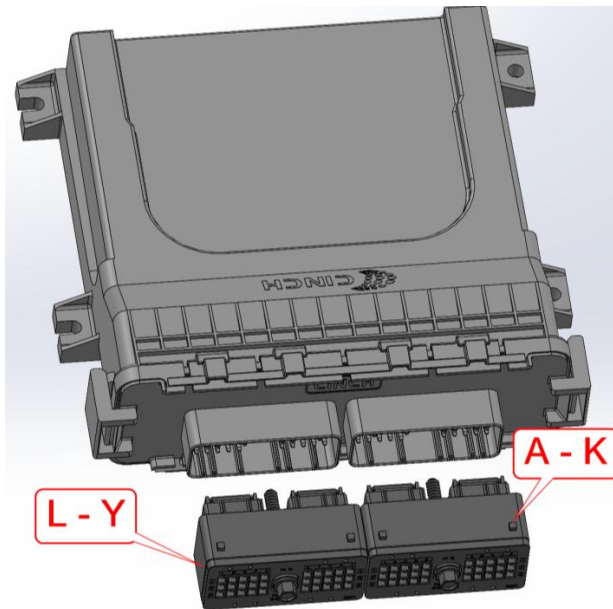

CONNECTOR	DESCRIPTION	CONNECTOR	DESCRIPTION
C1	CAN	C15	BELT CLEANER SOLENOID (U)
C2	CAN	C16	SEED DIS BOOM SOLENOID (U)
C3	LOW CURRENT	C17	OPEN
C4	LOW CURRENT	C18	BELT CLEANER SOLENOID (L)
C5	HIGH CURRENT	C19	SEED DIS BOOM SOLENOID (L)
C6	OPEN/ GUTTER DIS	C20	SEEDER AUGER (L)
C7	PNUEMATIC CONTROLS	C21	SEEDER SENSOR (L)
C8	SEEDER AUGER (U)	C22	CUTTER MOTOR (L)
C9	SEEDER SENSOR (U)	C23	BELT MOTOR (L)
C10	CUTTER MOTOR (U)	C24	BELT POS SENS - HVST (L)
C11	BELT MOTOR (U)	C25	SPRAYER MOTOR- FRONT- (L)
C12	BELT POS SENS - HVST (U)	C26	LIGHTS - FRONT (L)
C13	SPRAYER MOTOR- FRONT- (U)	C27	OPEN

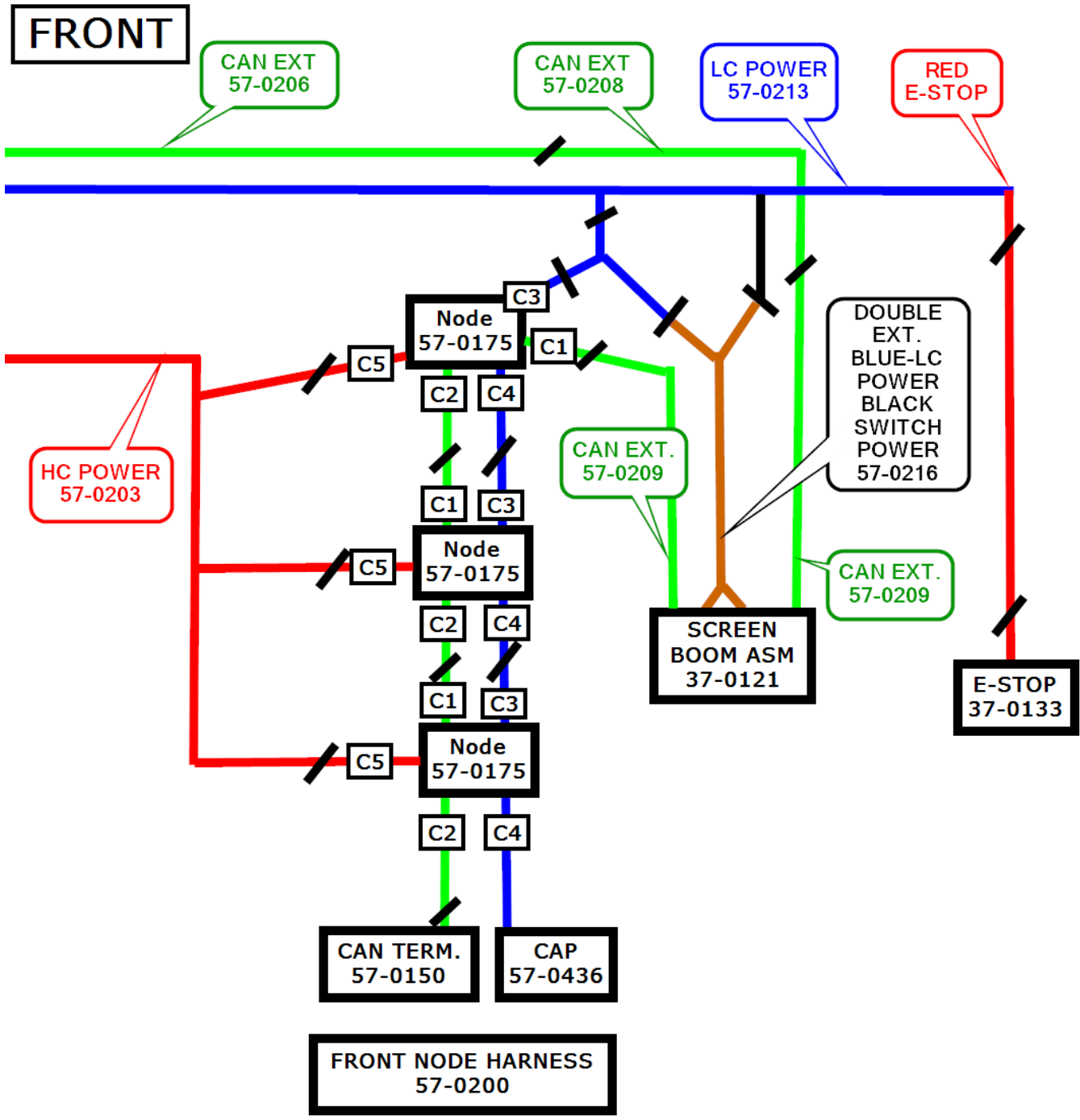

27.2. Daisy chain the CAN to CAN and ECU to ECU cables between nodes starting at the bottom wiring harness and working up from node to node.

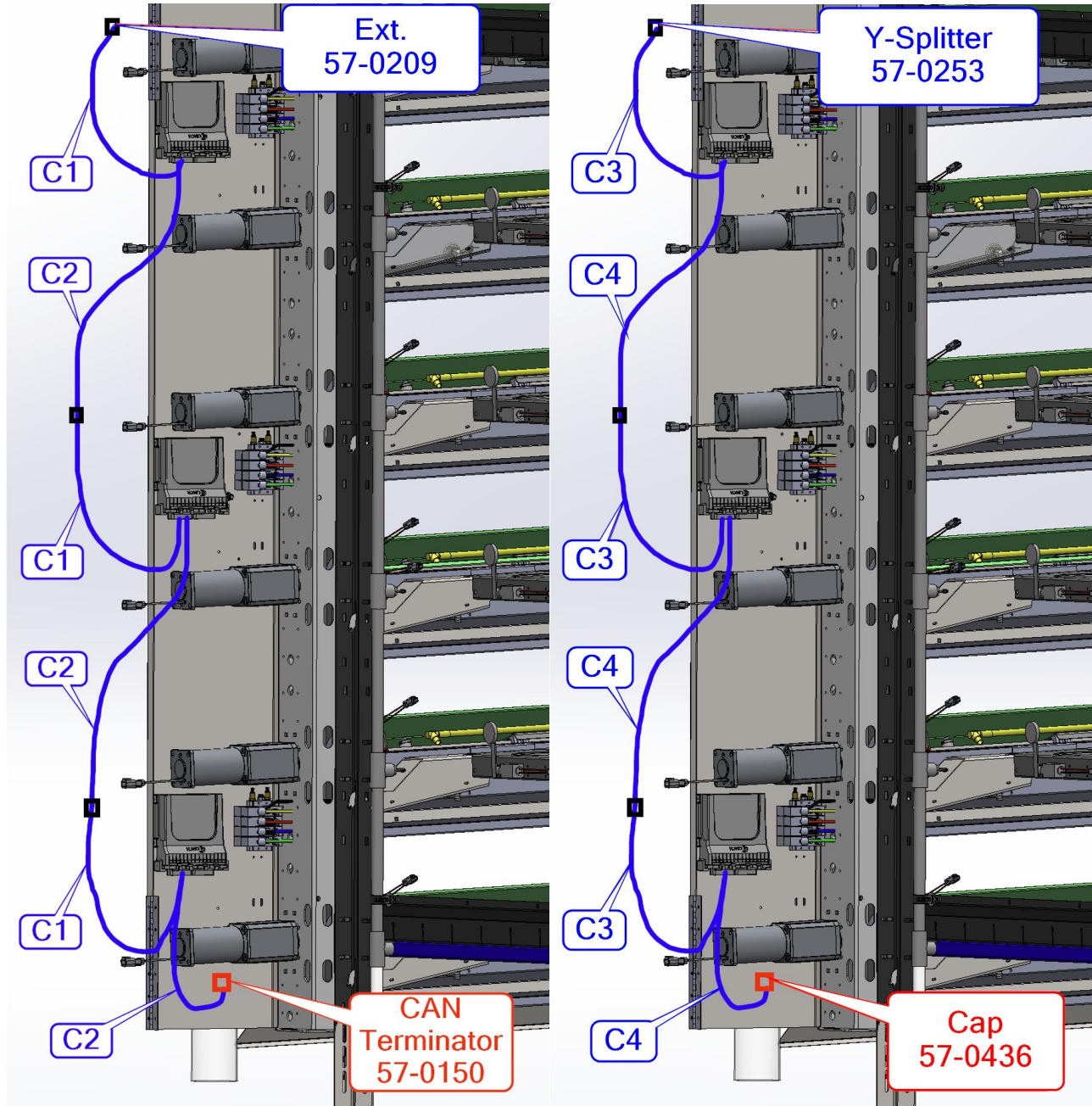

27.3. Run the wires through the holes in the front drive motor shield and onto the corresponding components. The wires are labeled with the corresponding components for each node (U) upper & (L) lower level designations.

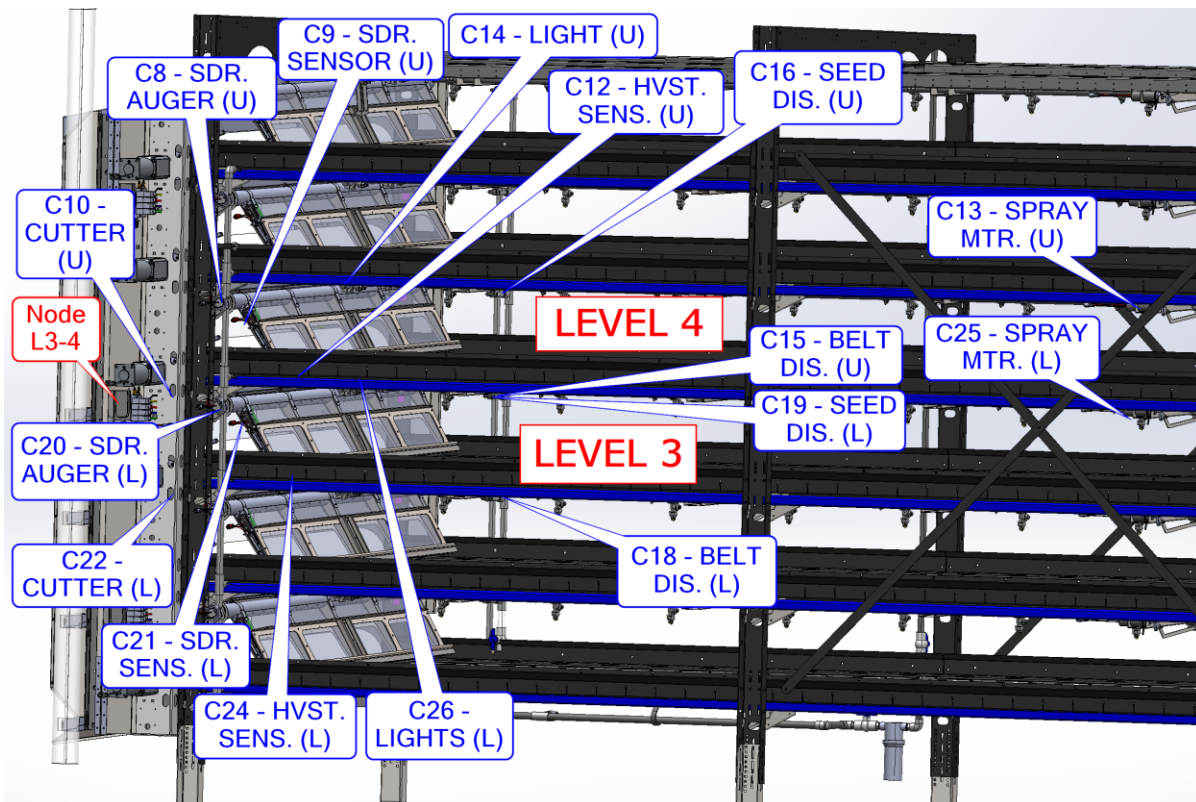
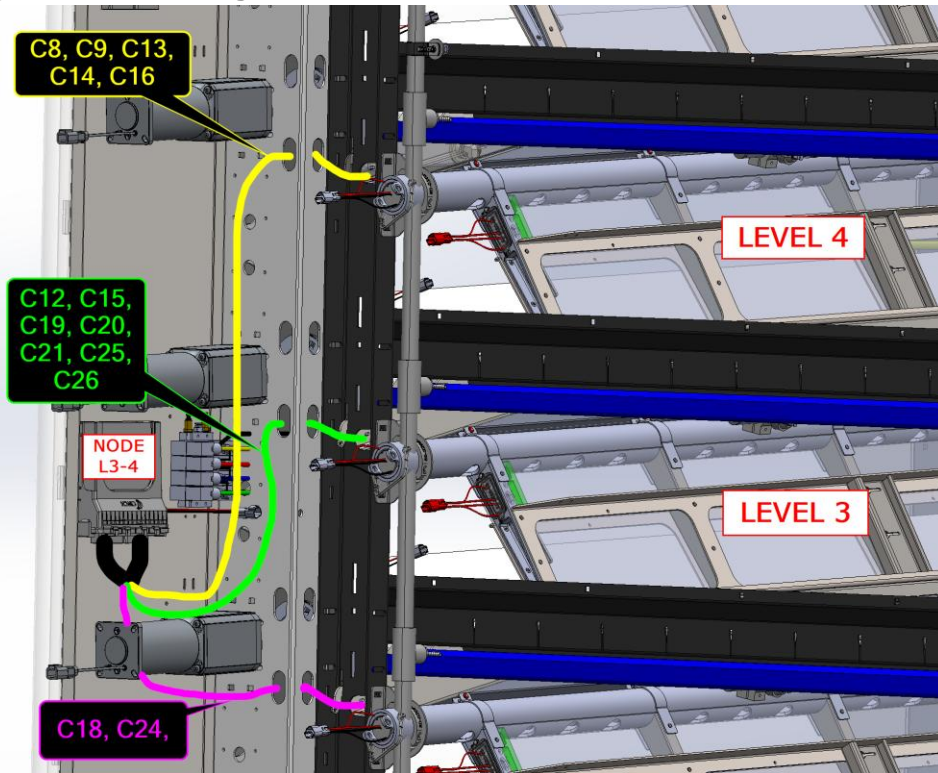

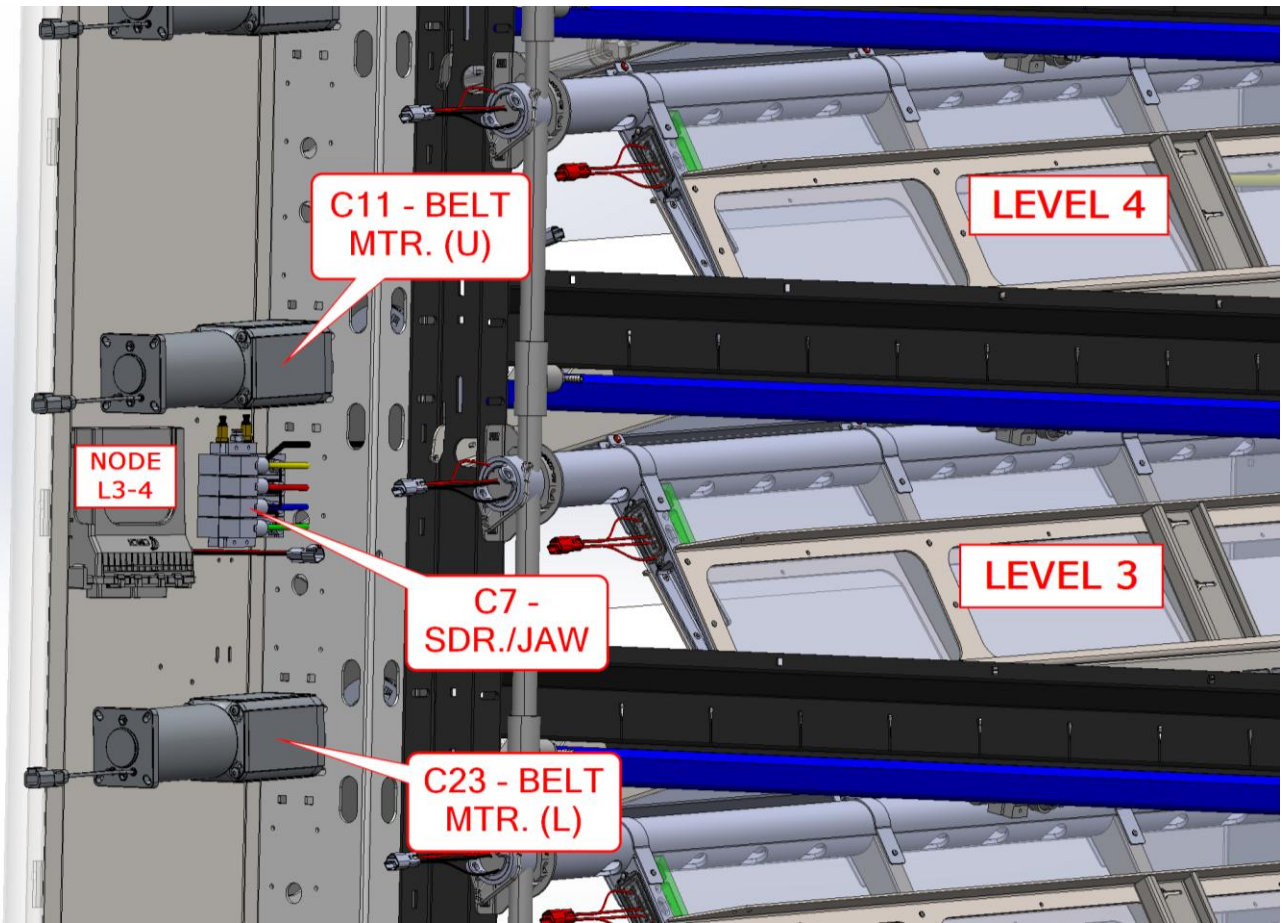

# 28. Rear Node Harnesses

Qty	Part #	Description	Pallet
1	57-0201	Harness, Node, Rear	15

28.1. Connect the rear wiring harness(57-0201) to the node.

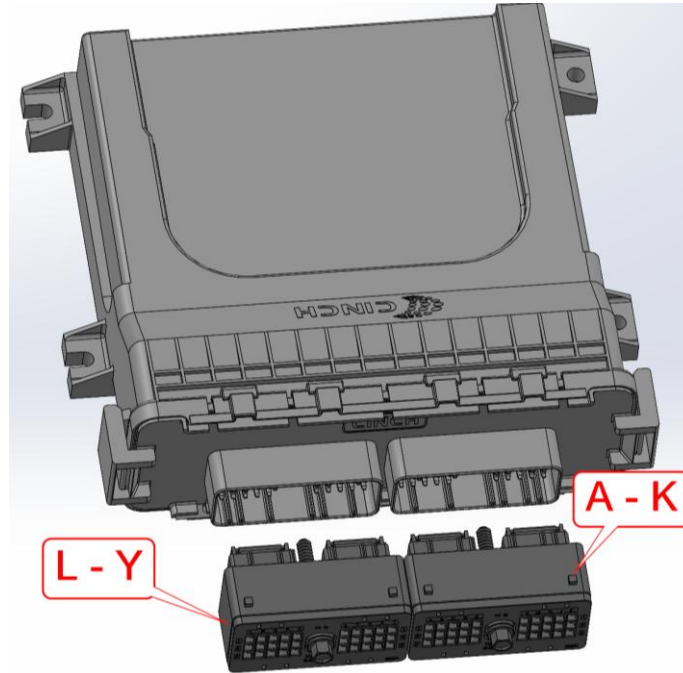

CONNECTOR	DESCRIPTION	CONNECTOR	DESCRIPTION
C1	CAN	C12	BELT POS SENS - SEED STOP (U)
C2	CAN	C13	DRIPPER SOLENOID - REAR (U)
C3	LOW CURRENT	C14	LIGHTS - REAR (U)
C4	LOW CURRENT	C15	BELT MOTOR (L)
C5	HIGH CURRENT	C16	SPRAYER MOTOR - REAR (L)
C6	OPEN	C17	SPRAYER SOLENOID - REAR (L)
C7	PNEUMATIC CONTROLS	C18	DRIPPER SOLENOID - REAR (L)
C8	BELT MOTOR (U)	C19	BELT POS SENS - SEED COMP. (L)
C9	SPRAYER MOTOR - REAR (U)	C20	BELT POS SENS - SEED STOP (L)
C10	SPRAYER SOLENOID - REAR (U)	C21	LIGHTS - REAR (L)
C11	BELT POS SENS - SEED COMP. (U)		

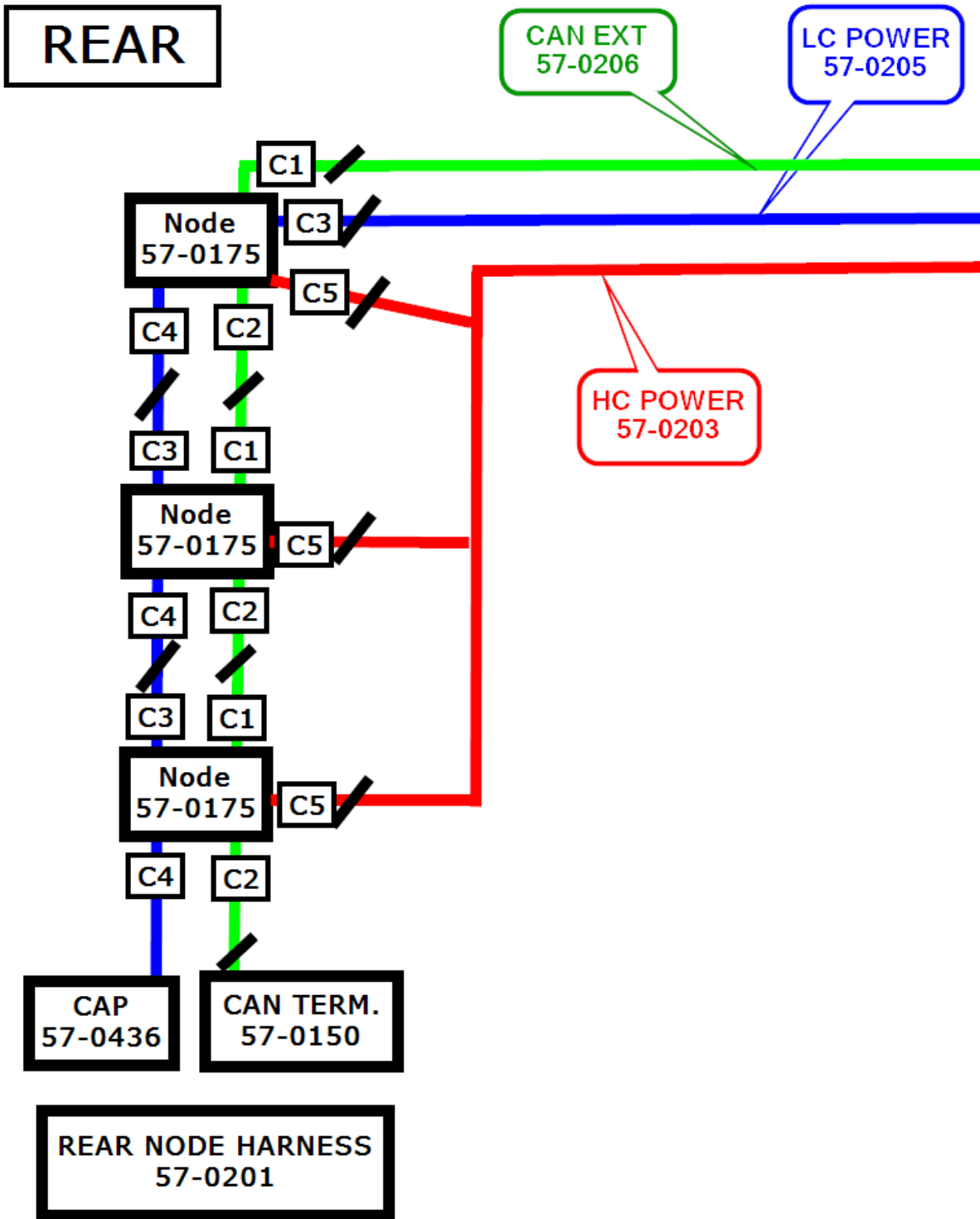

28.2. Daisy chain the CAN to CAN and ECU to ECU cables between nodes starting at the bottom wiring harness and working up from node to node.

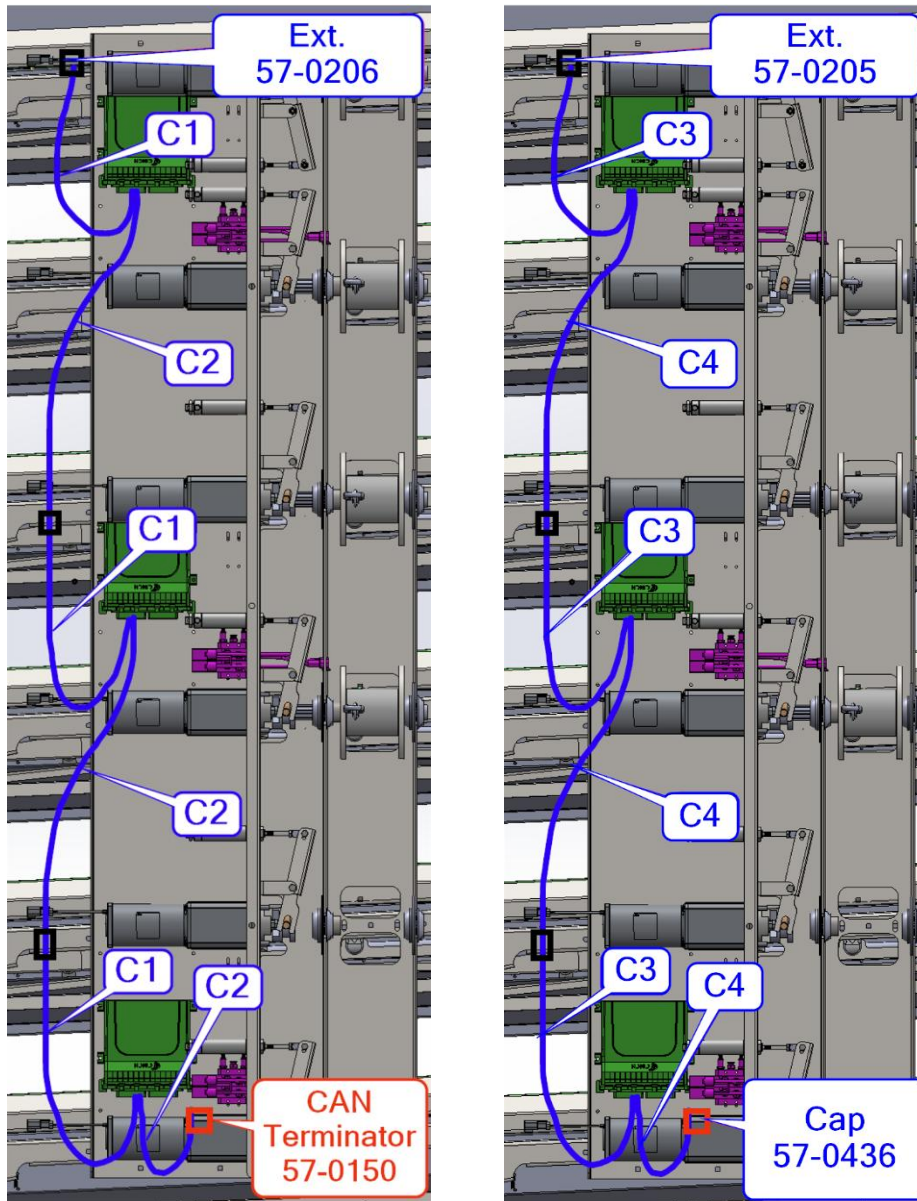

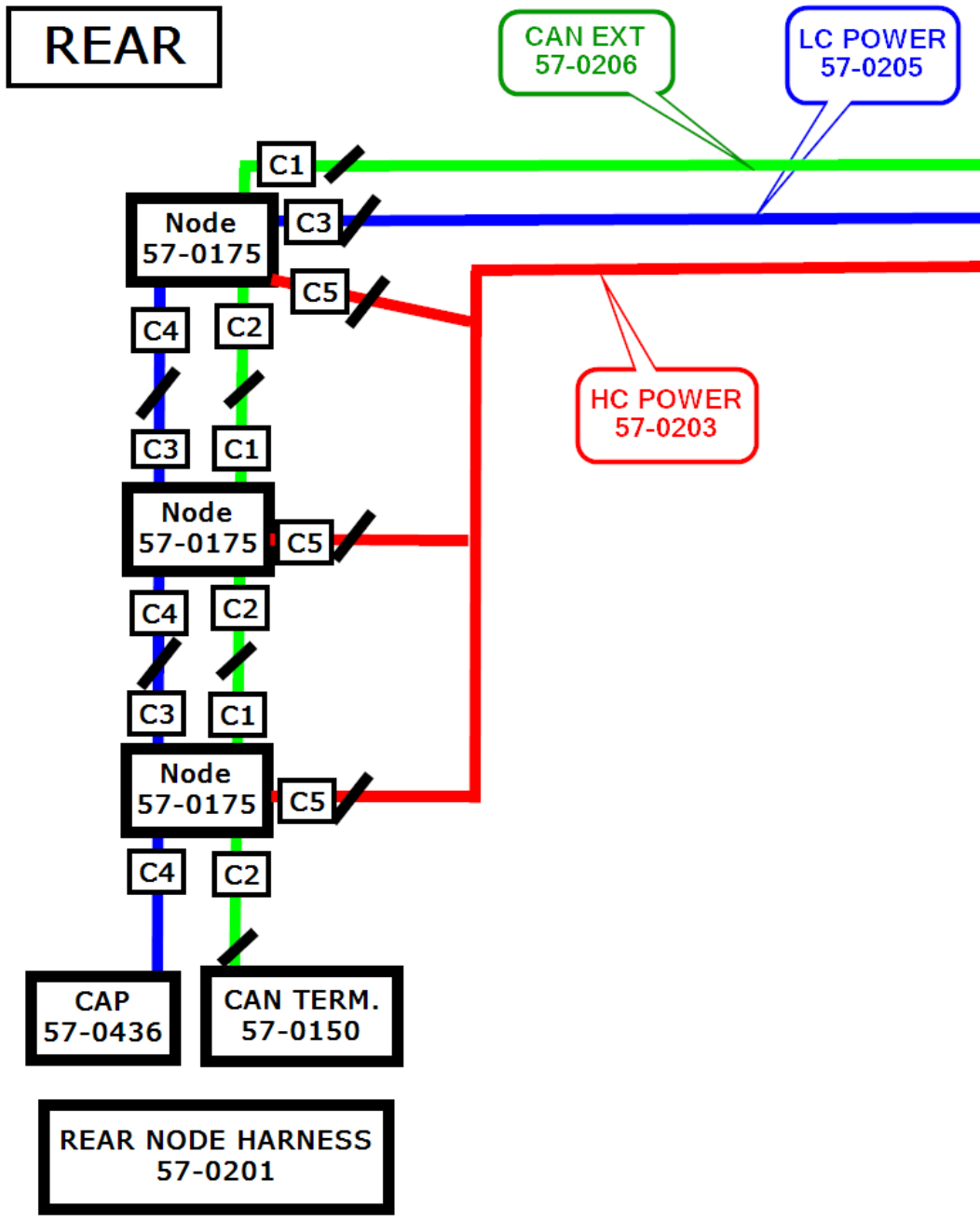

28.3. Route wires through holes in the pull back motor mount to the corresponding components.

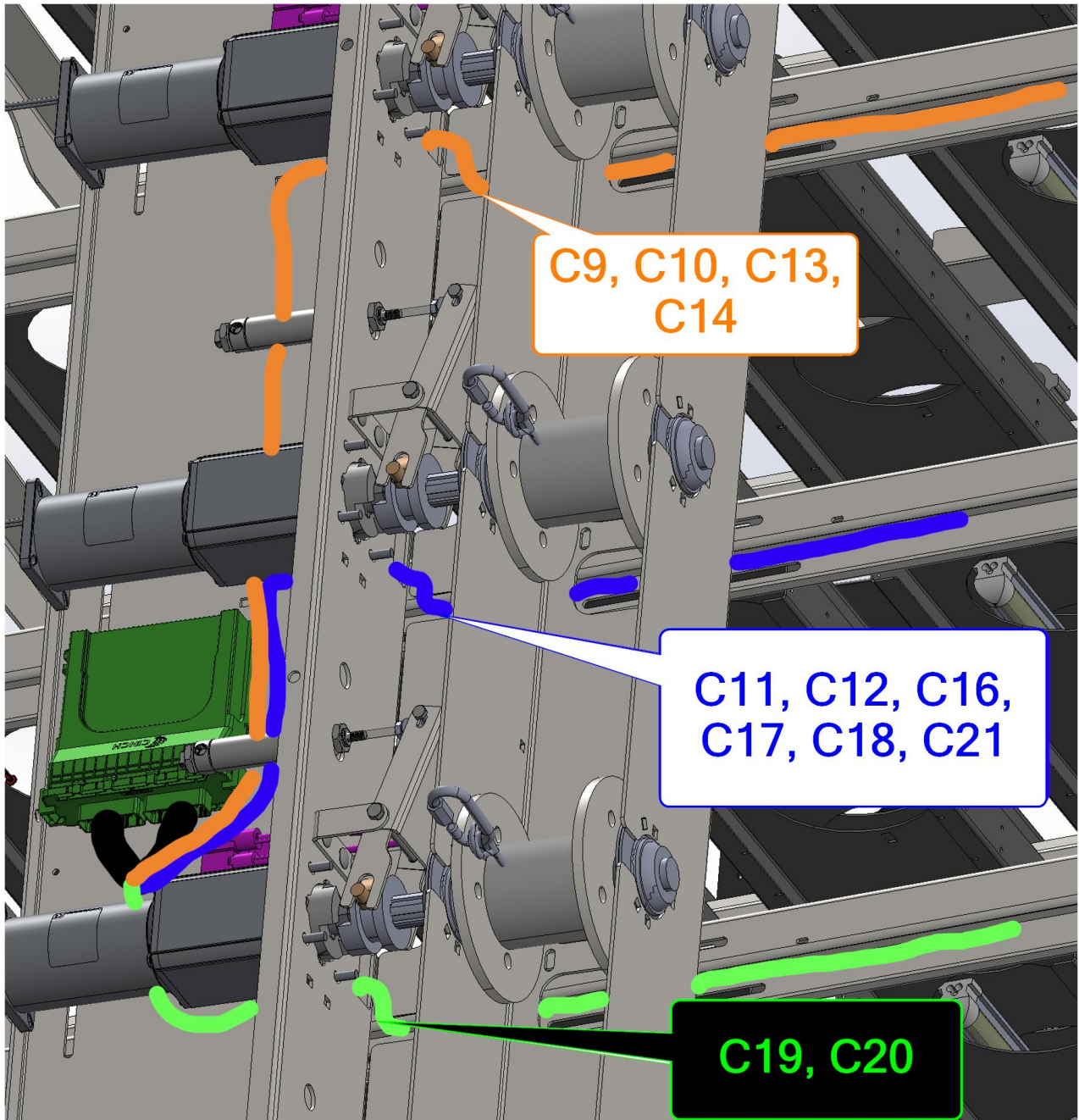

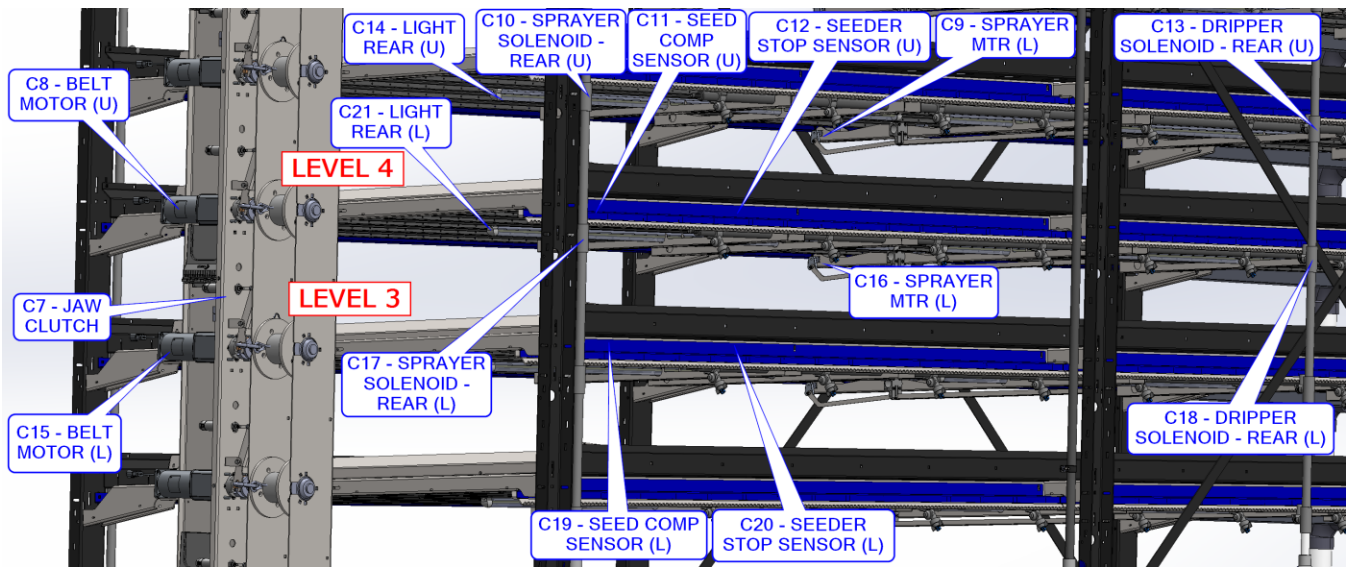

**28.4. Rear gutter disinfectant solenoid is connected to the low rear node plug “24v Extra” with harness 57-0243.**

## 29. Middle Node (1).

Qty	Part #	Description	Pallet
1	51-2394	Node Mount	?
1	30-0502	Kit, Nodes	15

29.1. Bolt middle node mount to the middle leg just below level 5 fastening it with two 5/16" carriage head bolt and flange nuts.

29.2. Attach node to the mounts using machine screws and nylon lock nuts.

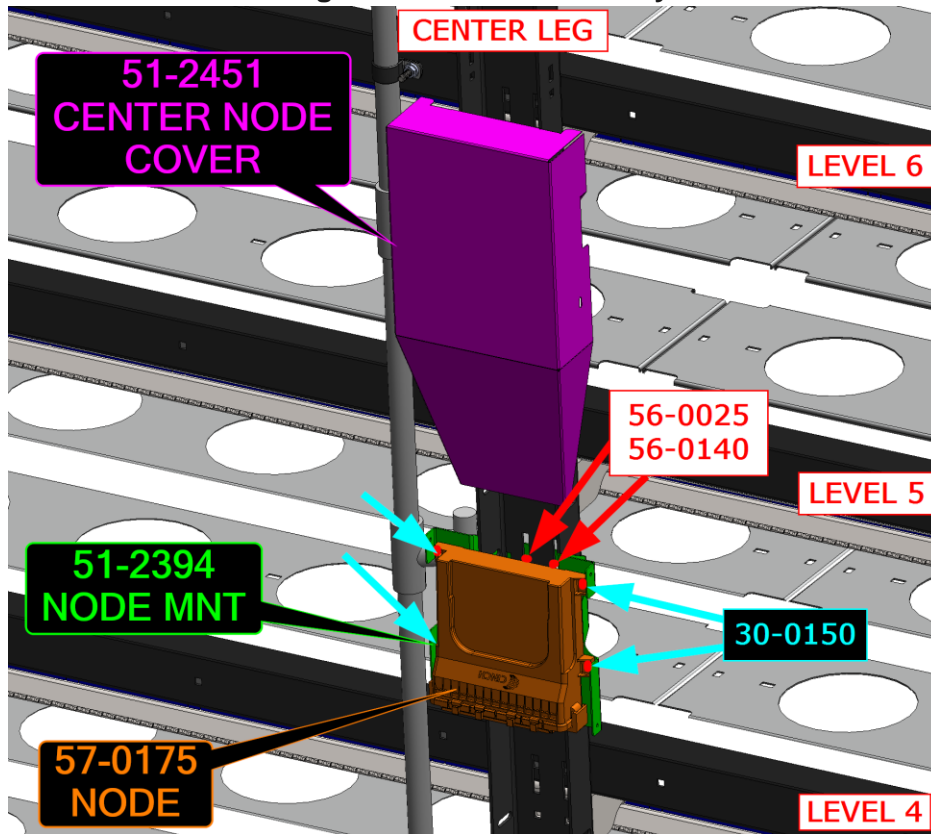

# 30. Middle Node Harness

Qty	Part #	Description	Pallet
1	57-0202	Harness, Node, Middle	15
2	57-0206	CAN Extension	15

30.1. Plug the middle wiring harness(57-0202) into the node and screw in the connectors, then run the wires up and down the leg to their corresponding components.

CONNECTOR	DESCRIPTION	CONNECTOR	DESCRIPTION
C1	CAN	C12	SPRAYER SOLENOID FRONT L2
C2	CAN	C13	SPRAYER SOLENOID FRONT L3
C3	LOW CURRENT	C14	SPRAYER SOLENOID FRONT L4
C4	LOW CURRENT	C15	SPRAYER SOLENOID FRONT L5
C5	HIGH CURRENT	C16	SPRAYER SOLENOID FRONT L6
C6	5V	C17	DRIPPER SOLENOID FROM L1
C7	PRESSURE PUMP	C18	DRIPPER SOLENOID FROM L2
C8	CHEM PUMP 1	C19	DRIPPER SOLENOID FROM L3
C9	CHEM PUMP 2	C20	DRIPPER SOLENOID FROM L4
C10	E-STOP	C21	DRIPPER SOLENOID FROM L5
C11	SPRAYER SOLENOID FRONT L1	C22	DRIPPER SOLENOID FROM L6

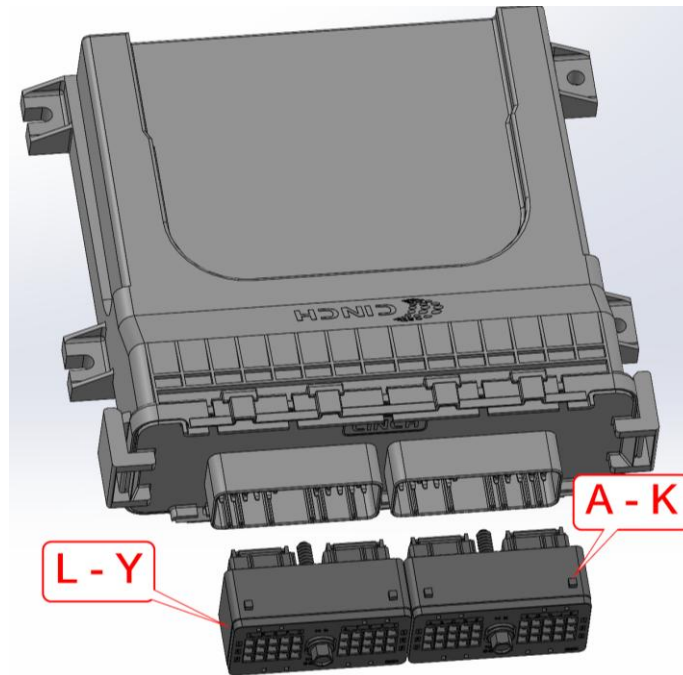

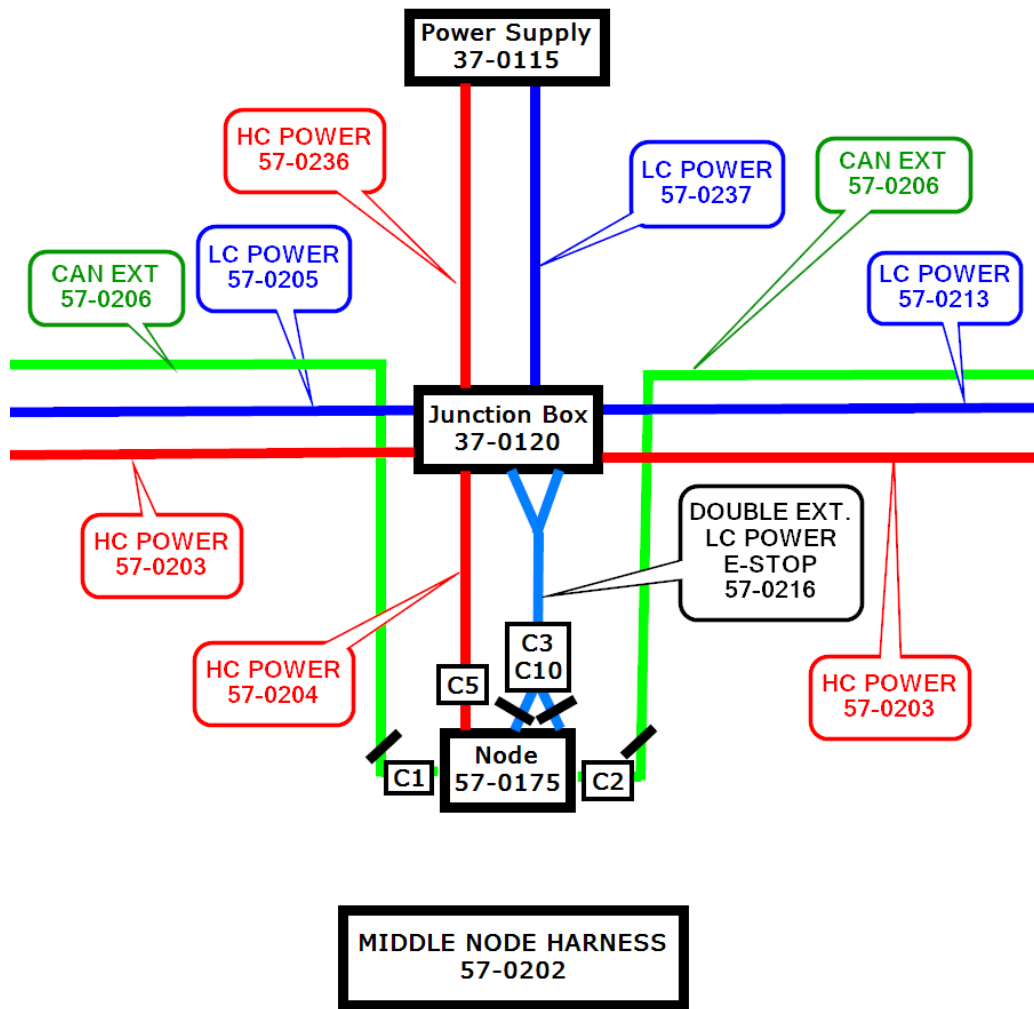

30.1.1. Route the wiring down the leg and into access whole per level of sprayer and dripper solenoids. Run the wire down the pan and connect to the solenoid.

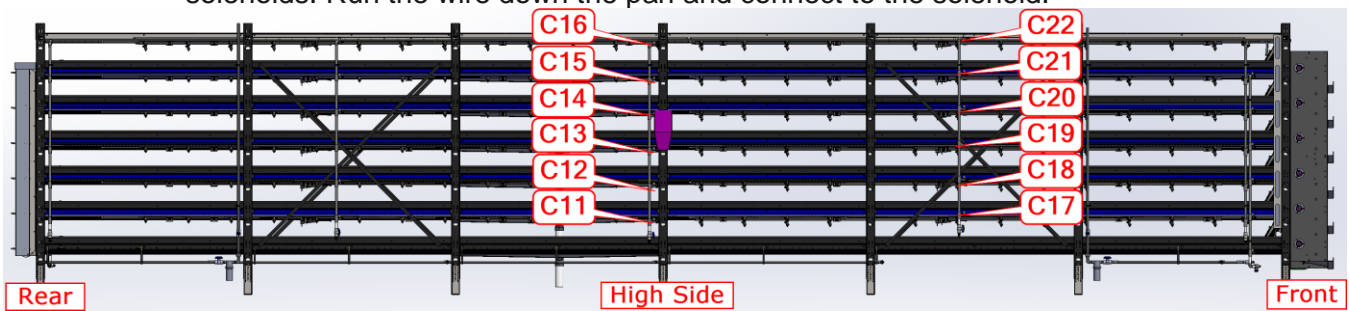

30.2. CAN extensions(57-0206) are provided to connect all the devices together. Starting at the top of the rear nodes, use the appropriate extensions to connect to the middle node, the to the screen, and from the screen to the front nodes. This should make a complete chain.

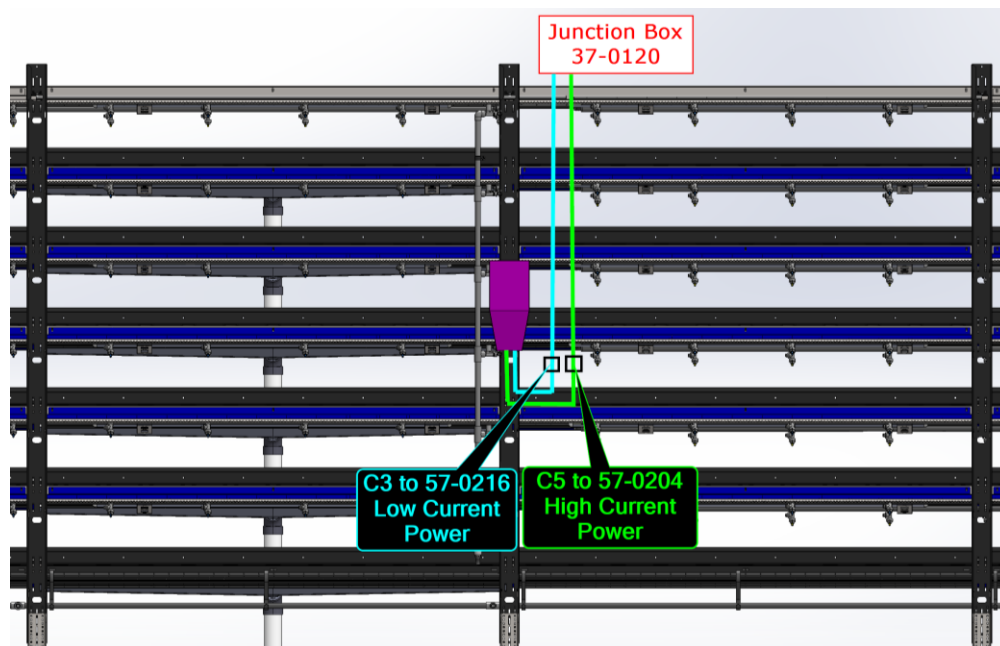
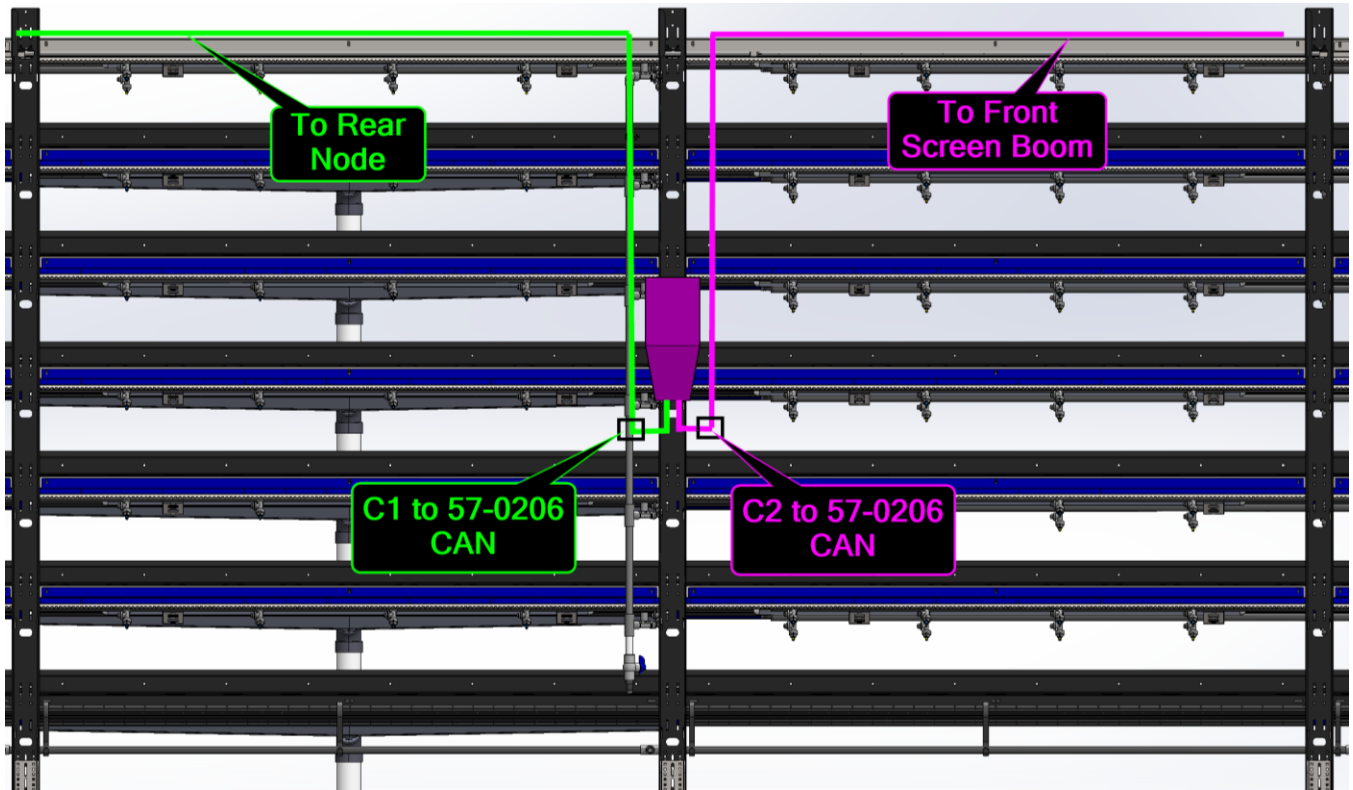

## 31. Install the screen case assembly.

Qty	Part #	Description	Pallet
1	30-0061	Kit, Screen Case & Boom Mount	1

**Note:** The ethernet cable for network access plugs into **LAN Port A** on the back of the terminal screen.

31.1.1. Insert the pipe into the 2" holes on the first **top support** so that the **screen** hangs in front of the harvest motor stack.

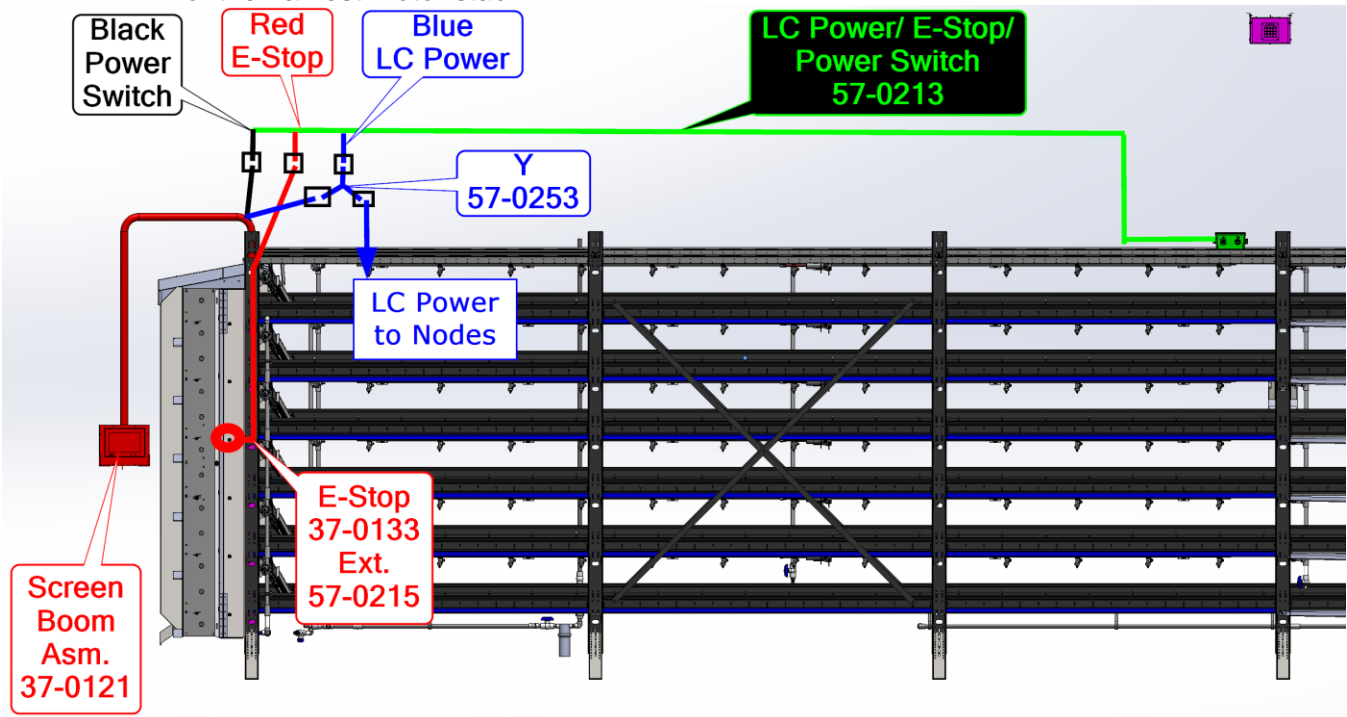

31.1.2. From the **Junction Box**, plug the **LC Power Extension** into the splitter, then plug one end into the screen wire labeled **Screen** and the other into the **LC Power Extension** for the **Front Nodes**.

31.1.3. Plug the **Switch Ext** into the screen wire labeled **Switch**.

31.1.4. The wires from the **screen** will be fed through a hole at the top of the screen pipe and be labeled with their corresponding wires from the extensions and the **front node wiring harness**.

## 32. Power Supply Box.

Qty	Part #	Description	Pallet
1	37-0115	Power Supply Box	15
1			

32.1. Mount the power supply box to the ceiling or above the table near the center of the table.  
The extension harness to junction box is 10 foot (3m).

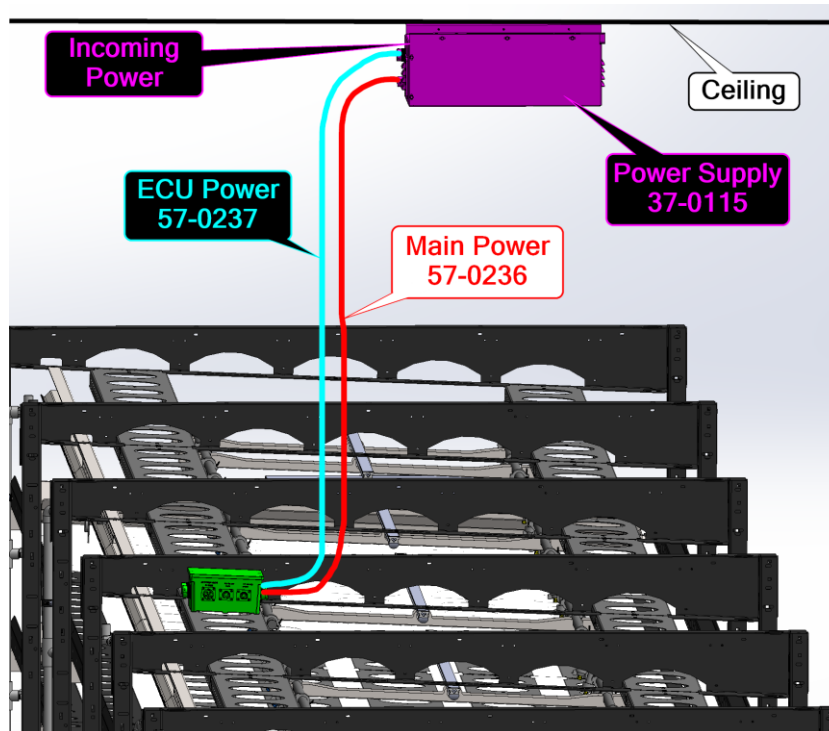
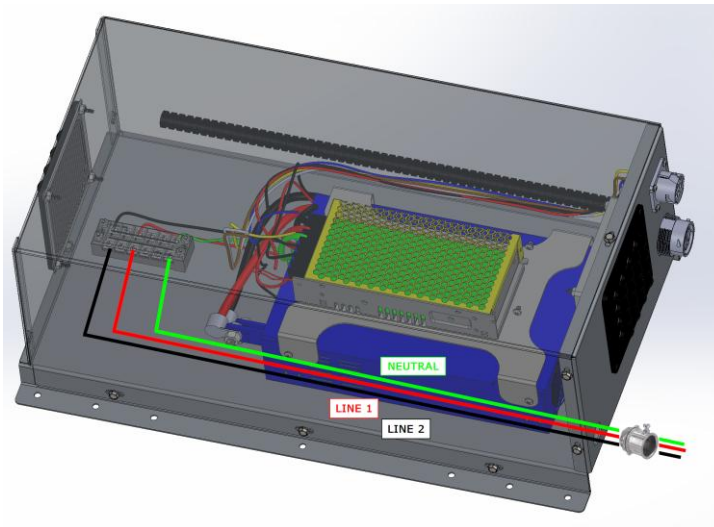

# 33. Junction Box

Qty	Part #	Description	Pallet
1	37-0120	Junction Box	15

33.1. Mount the junction box to the pan above level 6 at the middle leg on the high side.

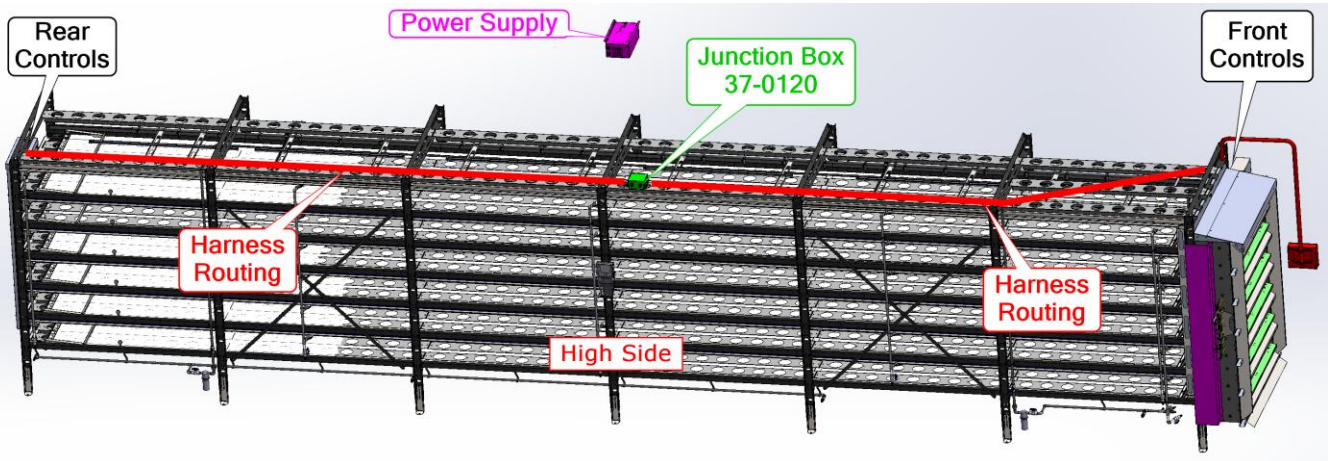

33.2. Run the HC power and ECU power extensions from the power supply box to the junction box and plug into the appropriate connectors.

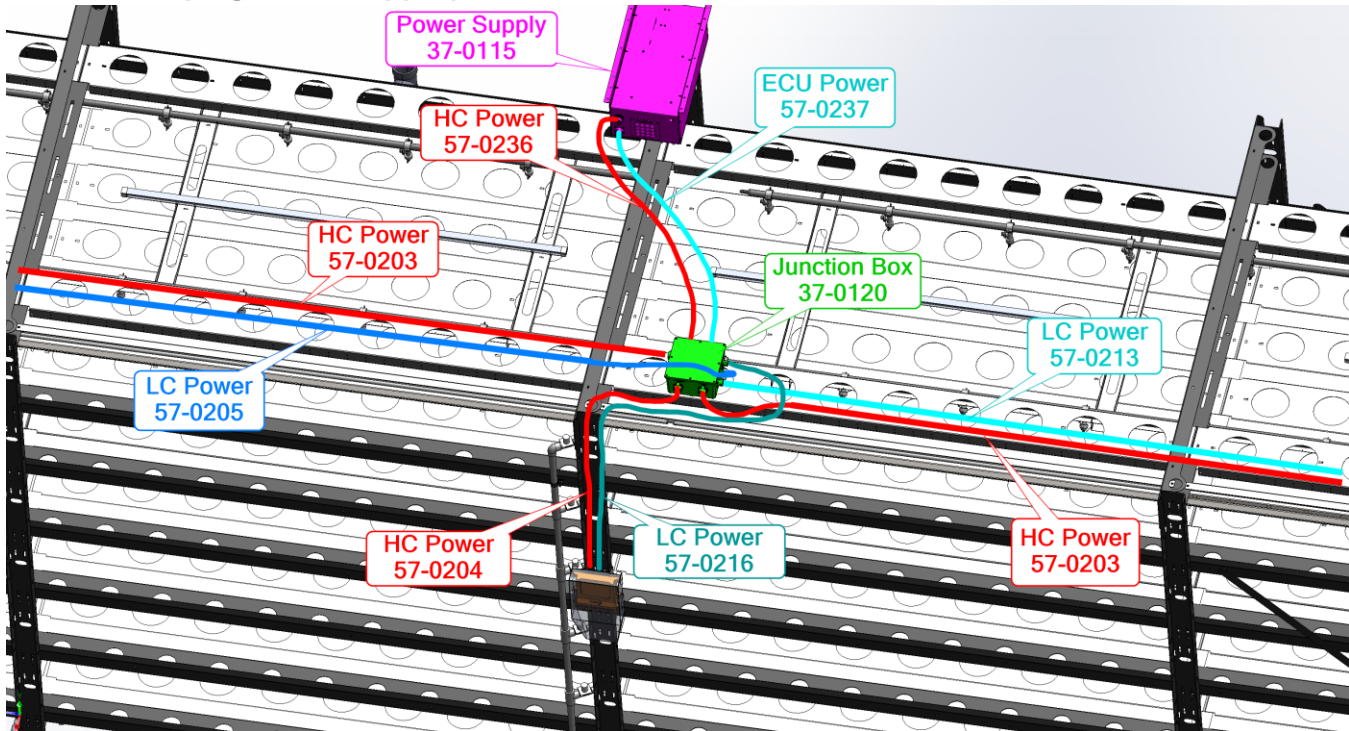

33.3. Run cable extensions from the junction box to the nodes and screen.

**Note:** The screen extensions will connect to wires in the top of the screen case assembly pipe.

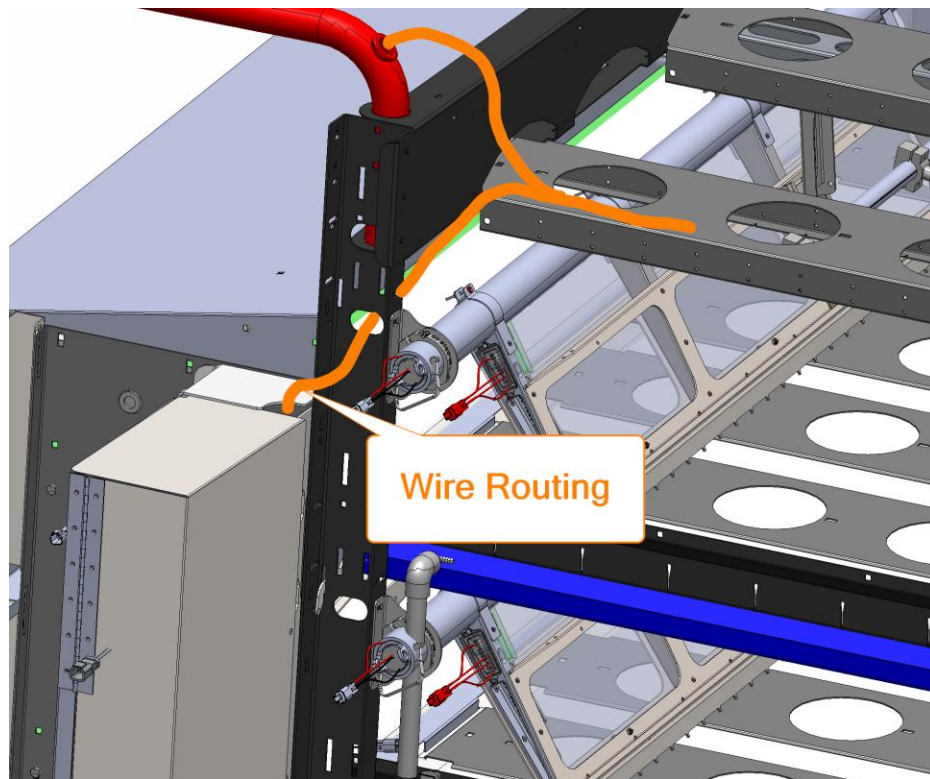











**33.4. Install CAN cable extensions to finish daisy-chaining the nodes and screen together.**

**Note:** One **CAN** cable goes to the front nodes from the screen. The other **CAN** cable coming out of the screen boom runs to the rear nodes and splits out for the middle nodes along the way.

# 34. Water Mainline

Qty	Part #	Description	Pallet
1	30-0013	Kit, Plumbing Irrigation	11
1	21-0102	Bundle, Water Supply	14

REV: 02			<b>013</b>
<b>Part #</b>	<b>30-0013</b>		
<b>Description</b>	<b>KIT, PLUMBING, IRRIGATION, DGS</b>		
<b>Part #</b>	<b>Qty</b>	<b>Description</b>	<b>Picture</b>
30-0157	2	WATER MANIFOLD MOUNTING FASTENERS	
35-0079	6	HOSE, WATER, BLUE, 3/4" X 18"	
35-0114	2	HOSE, WATER, BLUE, 3/4"	
35-0157	1	PIPE ASM, WATER SUPPLY, SUB ASM 2/4, DGS	
35-0158	2	PIPE ASM, WATER SUPPLY, SUB ASM 3/4, DGS	
35-0159	1	TEE, PVC, .75" SOC TO .75" HB, END CAP, ASM	
35-0160	1	TEE, PVC, .75" SOC TO .75" HB, ASM	
35-0161	1	TEE, PVC, .75" REGULATOR W/ HB, ASM	
35-0162	1	ELBOW, PVC, .75", REGULATOR W/ HB, ASM	
35-0181	2	MANIFOLD, WATER SUPPLY ASM, DGS 66	
35-0183	1	MANIFOLD, WATER SUPPLY, DSG 66, ELBOW TO TEE SUBASM	
35-0184	1	MANIFOLD, WATER SUPPLY, DGS 66, ELBOW TO ELBOW SUBASM	
53-0091-01	4	Clamp, Steel, Vinyl Coated, 1"	
54-0064-00	2	MESH SCREEN, 100 MESH, 3/4"	
55-0122-00	16	HOSE CLAMP, SS, 9/16" TO 1-1/16"	
79-0045-00	1	Box, Cardboard, DW, 275LB, 16'x12'x8'	

21-0102 DGS 66, Water Supply Bundle			
ITEM NO.	PART NUMBER	DESCRIPTION	QTY.
1	35-0153	PIPE, PVC, SCH 80, GRAY, .75" X 94"	3
2	35-0154	PIPE, PVC, SCH 80, GRAY, .75" X 102"	1
3	35-0185	PIPE, PVC, SCH 80, GRAY, .75" X 106"	1
4	35-0186	PIPE, PVC, SCH 80, GRAY, .75" X 75"	1
5	35-0187	PIPE, PVC, SCH 80, GRAY, .75" X 48"	1

### 34.1. Layout out the Irrigation Mainline on the floor starting in the rear of the machine

34.1.1. Verify all the parts are there

34.1.2. Dry fit mainline and hang it on S-hooks 51-2510

34.1.3. Mount the Irrigation water inlet with clamps to levels 2 & 6

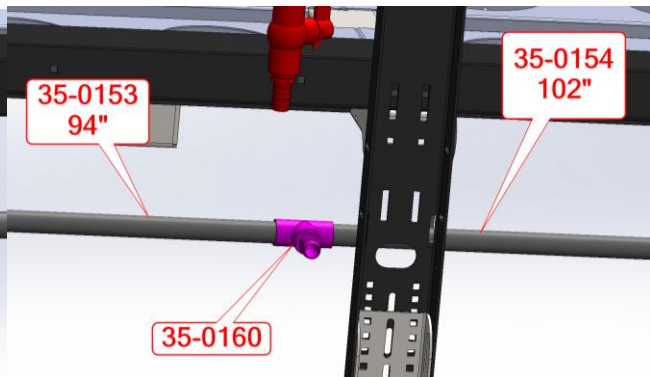
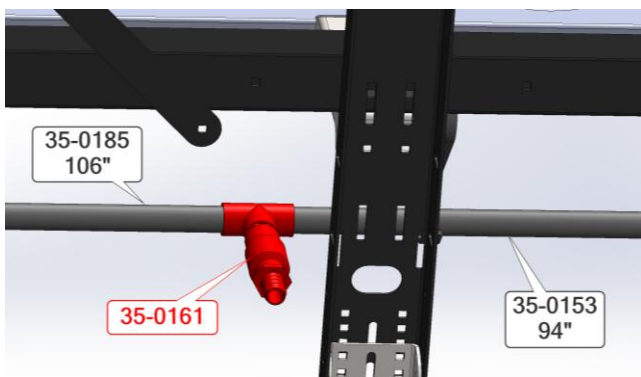
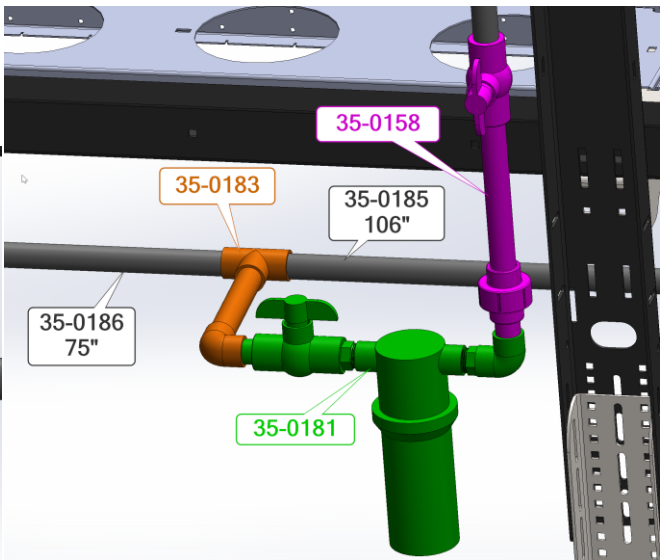
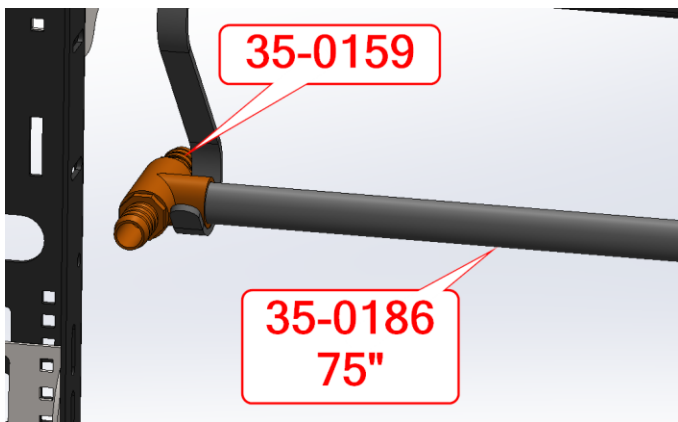
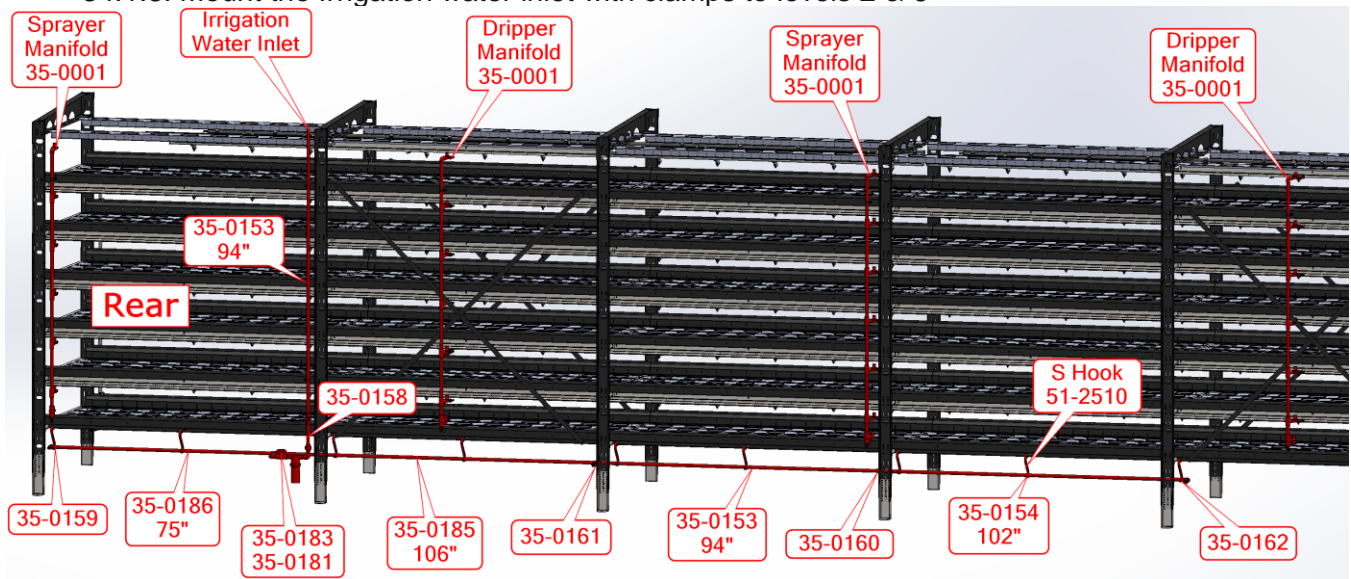

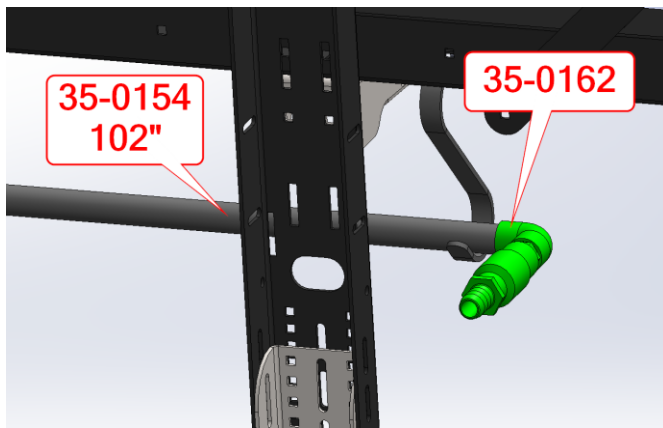

### **34.2. Install Manifold Hoses**

34.2.1. Install four 3/4" x 18" water hoses (35-0079) between the mainline and the sprayer & dripper hoses. Secure them with hose clamps 55-0122

1.5.2. Install hose 35-0114 from mainline to rear gutter manifold securing it with hose clamps 55-0122

### **34.3. Prime and Glue Irrigation mainline**

34.3.1. Starting with the filter assembly 35-0181, prime and glue 35-0158 & 35-0183.

34.3.2. Add up right 35-0153 adjusting clamps if needed.

34.3.3. Work your way to the rear attaching 35-0186 & 35-0159

34.3.4. Work your way to the front attaching remaining parts

### 34.4. Layout out the Disinfectant Mainline on the floor starting in the front of the machine

34.4.1. Verify all the parts are there

34.4.2. Dry fit mainline and hang it on S-hooks 51-2510

34.4.3. Mount the Irrigation water inlet with clamps to levels 2 & 6

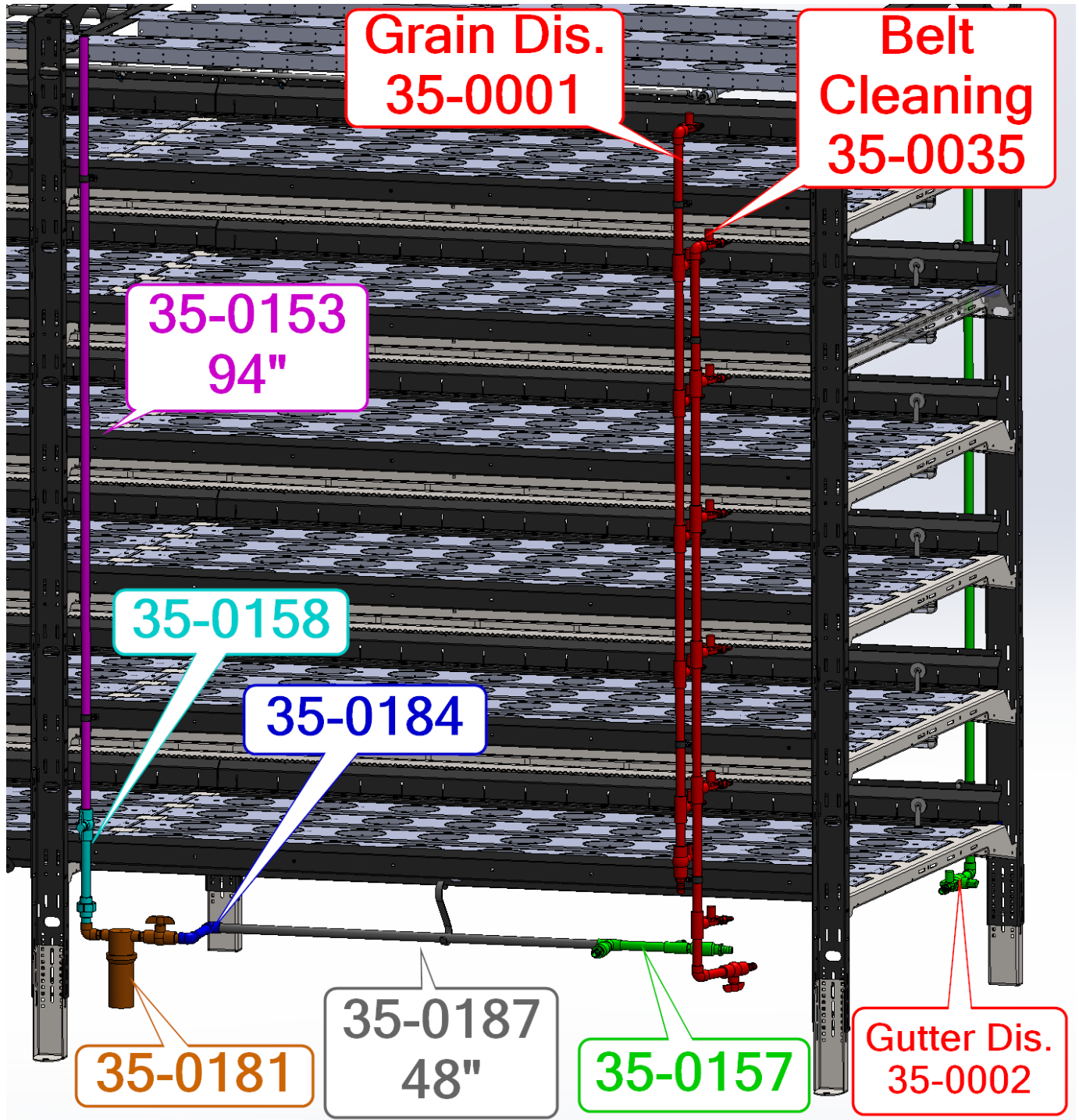

### 34.5. Install Manifold Hoses

34.5.1. Install four 3/4" x 18" water hoses (35-0079) between the mainline and the sprayer & dripper hoses. Secure them with hose clamps 55-0122

1.5.3. Install hose 35-0114 from mainline to front gutter manifold securing it with hose clamps 55-0122

#### **34.6. Prime and Glue Irrigation mainline**

34.6.1. Starting with the filter assembly 35-0181, prime and glue 35-0158 & 35-0184.

34.6.2. Add up right 35-0153 adjusting clamps if needed.

34.6.3. Work your way to the forward attaching 35-0187 & 35-0157

# 35. Guards & Drains

Qty	Part #	Description	Pallet
1	51-2191	Front Top Shield	13
1	51-2233	Front Drive Motor Shield Door	10
6	51-2020	Belt Cleaning Drain	10
1	51-1982	Clutch Guard	13
1	51-2006	Rear Drip Cover	13
1	51-2451	Middle Node Cover	13

## 35.1. Front top shield.

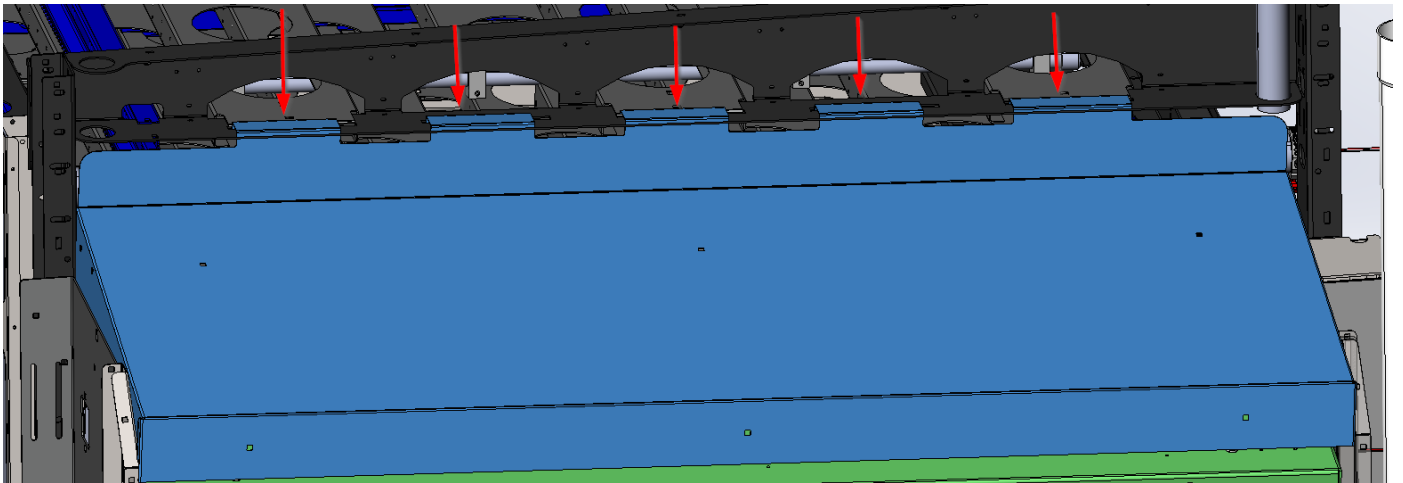

35.1.1. The front top shield tabs fit into slots on the top-level cross brace.

35.1.2. Secure the shield with 4 bolts inserted through the side unload plate.

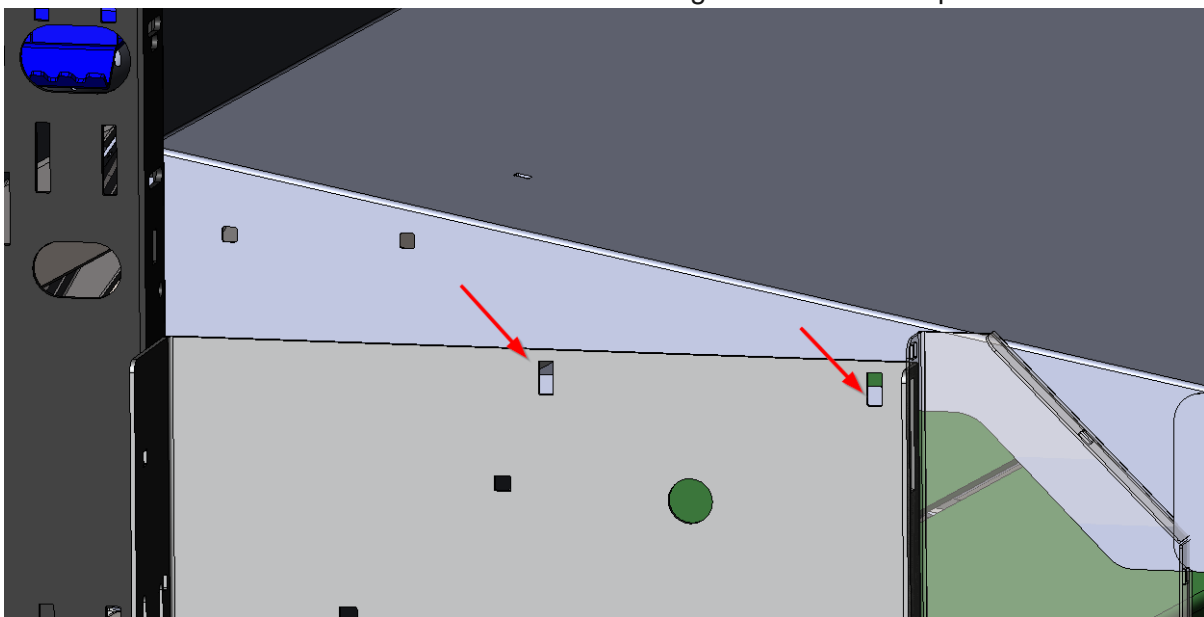

35.2. Motor guard, front chute side plate, belt cleaning drain, and front drive motor shield door.

- 35.2.1. Use carriage bolts to bolt the motor guard to the unload side plate on the high side of the table.
- 35.2.2. The front chute side plates get bolted to the end of the unload side plates using carriage bolts. The notches on the front chute side plate will sit around the gutter extensions of the unload chute.

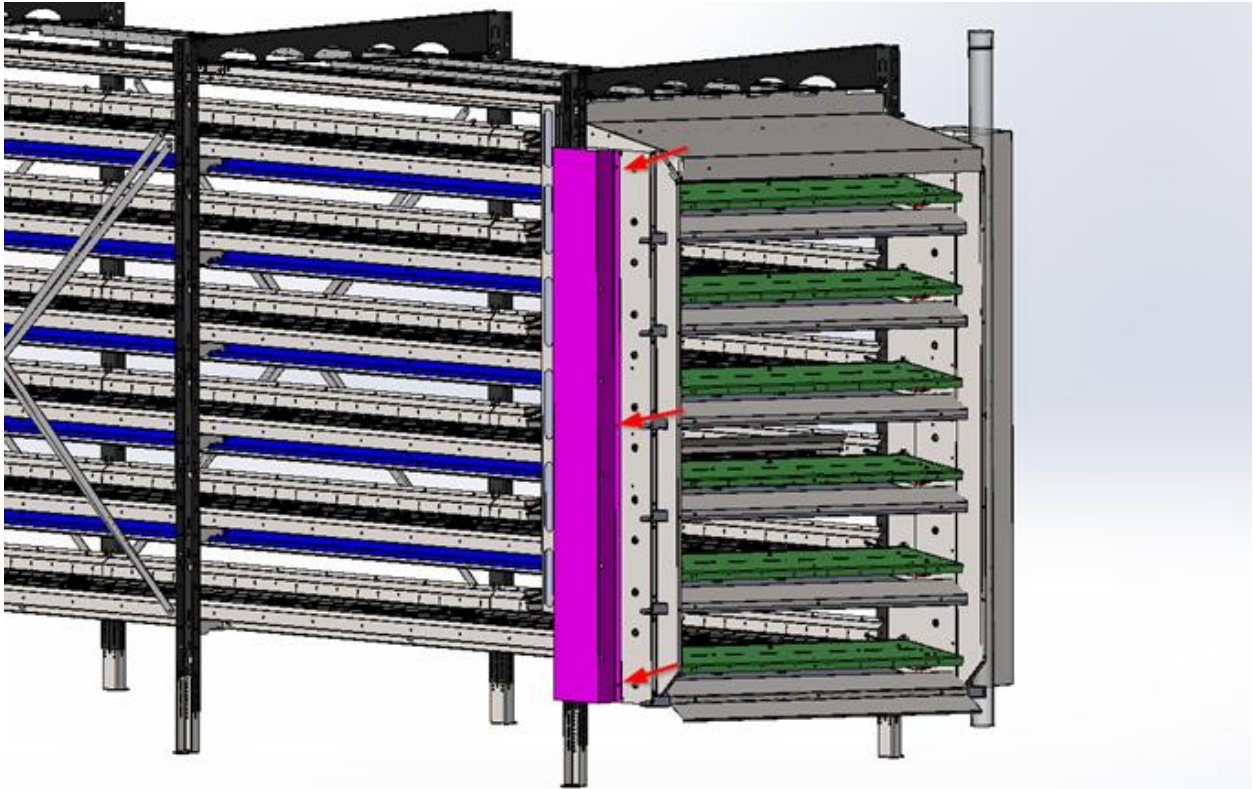

- 35.2.3. Bolt the belt cleaning drain to the front gutter of the unload chute.

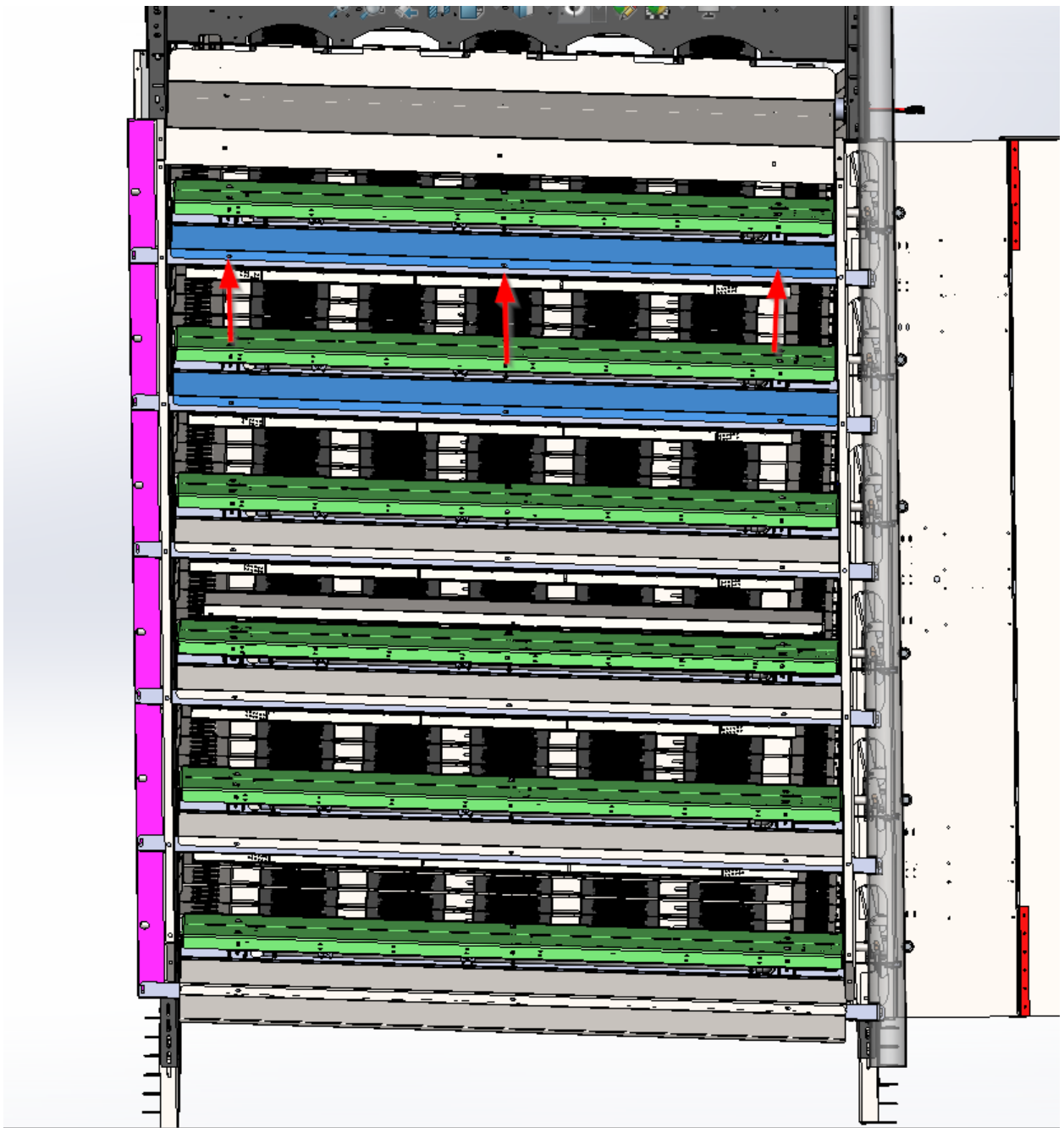

35.2.4. Mount the front drive motor shield door to the other half of the piano hinge on the front drive motor shield.



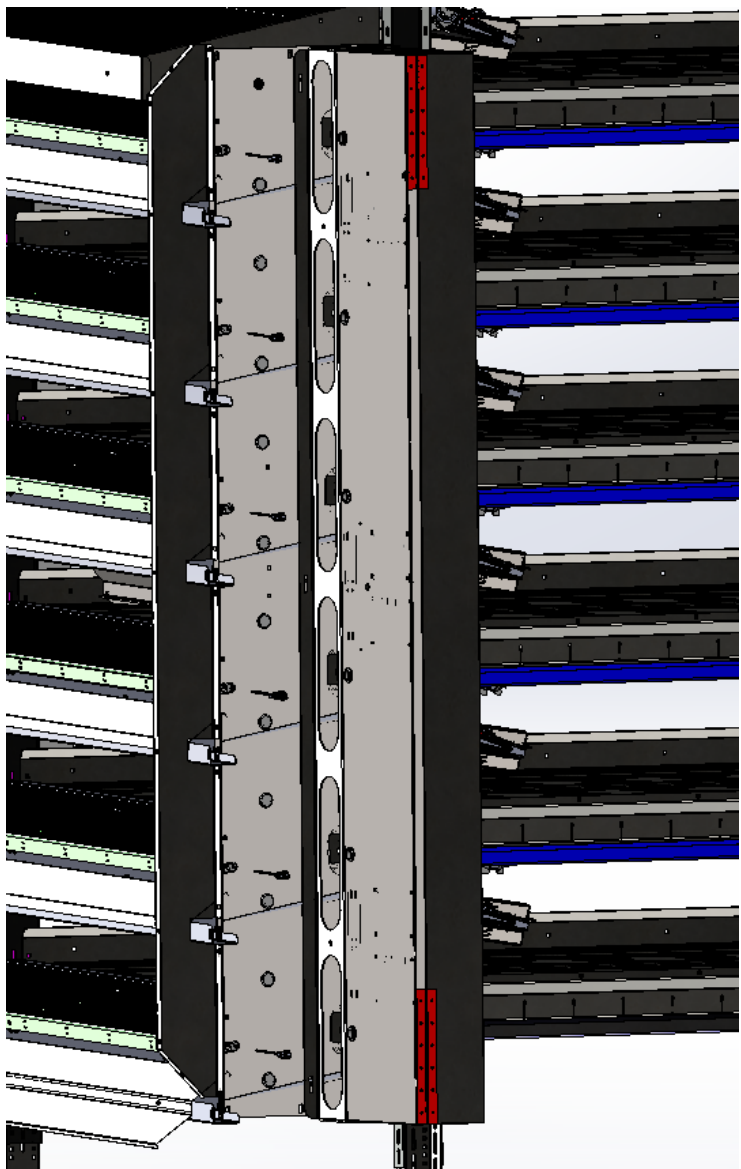

### 35.3. Clutch guard

35.3.1. Attach the polycarbonate jaw clutch cover, rear to the clutch guard.

35.3.2. Install jack nuts into the low side holes on the pull back motor mount.

35.3.3. The clutch guard then gets screwed to the pull back motor mount. Once the clutch guard is attached, the rear drip cover can be slid on top of the clutch guard.

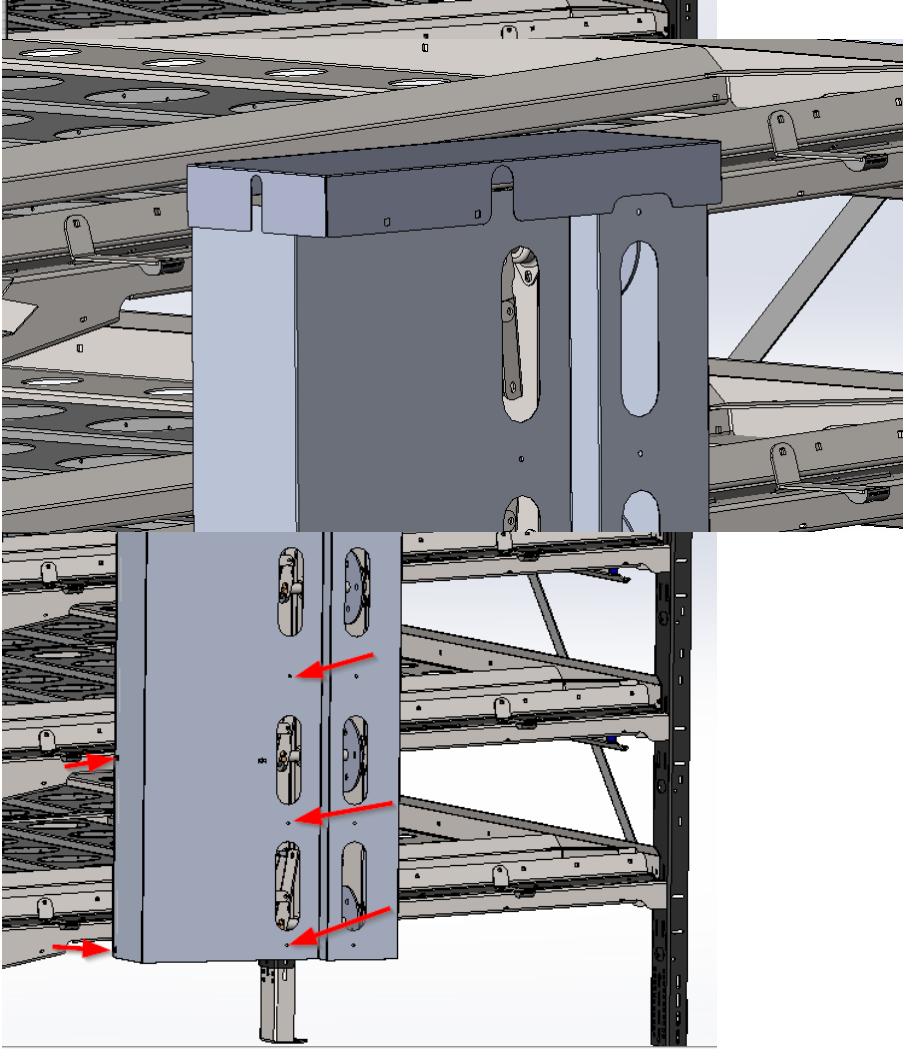

### 35.4. Install the front drain pipe on the low side gutter ends of the unload chutes. Install the middle drain pipe on fourth section of the machine.

35.4.1. Insert the **E-stop** into the middle hole of the **front node cover**.

**Note:** The **E-stop** ships unpinned from the connector to fit through the hole.

35.4.2. Pin the two wires onto the connector by sliding the pins into the receptacle and pushing until the pins are seated into the housing.

Pin	Wire Color
PIN 1	Black
PIN 2	Red

35.4.3. Install middle node cover.

## **36. Kits & Pallets**

---

HG SharePoint\Documents\Support Documents

[DGS 66 30-Kits 2024.pdf](#)

[DGS 66 Pallet Labels and Images.pdf](#)

