

100% manufactured from raw materials to provide the best cooking experience, a high standard of quality, and the highest durability in its class to meet the needs of a commercial kitchen.

CONSULTANT / CONTRACTOR NOTES:



Range With Standard Oven

FGR4B

Standard Features:

RANGE

- High efficiency open burners.
- 1-year parts and labor warranty.
- Available in 24" and 36" width.
- Stainless steel panel and sides.
- 12" x 12" cast iron top grates designed for easy movement of pots across top sections.
- Deflectors to direct waste to crumb/drip pan.
- Large front panel, promoting safety and great functionality.
- Chrome plated injected aluminum knobs providing for better toughness and durability.
- Easily removable stainless steel crumb/drip pan.

OVEN

- High efficiency open burners.
- Oven with snap action thermostat from 210°F to 550°F and 100% safety shut off.
- 26 1/2" Standard bakery depth on all ovens.
- Double-sided enamel oven cavity (Exterior and interior top, bottom, and side).
- Heavy-duty oven wired rack - 1/8" diameter.
- The standard oven has 3 shelf positions and 1 rack.
- Counterweight balanced doors for easy opening.

FGR4B

Range With
Standard
Oven

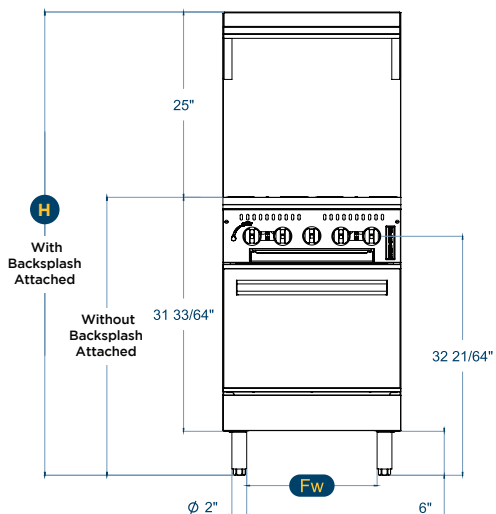

FRONT

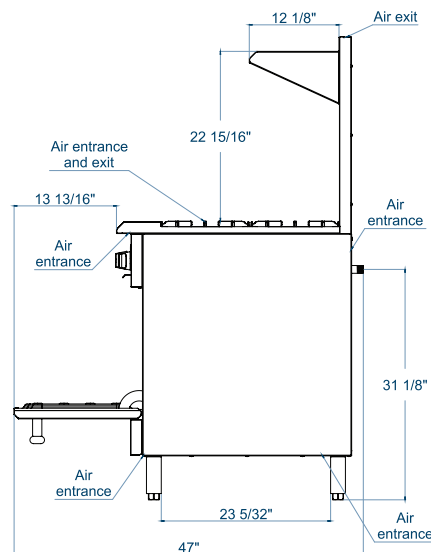

SIDE

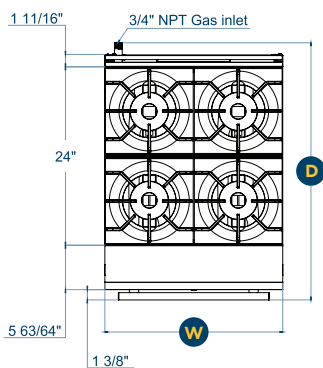

TOP

SPECIFICATIONS

- Manifold pressure is 4" W.C. (Natural Gas) or 10" W.C. (Propane Gas).
- 3/4" NPT rear gas connection and pressure regulator for both natural gas and propane.
- Check the altitude specifications above 2,000 ft.

Models	Exterior Product Dimensions & Weight						Shipping Crate Dimensions & Weight				Oven - Inside			
	Width (W)	Depth (D)	Height (H)		Fw		Weight	Width	Depth	Height	Weight	Width	Depth	Height
			W.O.B.S.A.	W.B.S.A.	Fw1	Fw2								
FGR4B	24"	35"	41 17/64"	62 33/64"	17 19/32"		276 lb	28 5/32"	39 1/64"	45 43/64"	397 lb	18 57/64"	26 1/2"	15 23/64"

UTILITY INFORMATION

Models	Burners (Range)	GAS SUPPLY										
		Propane		Natural		Burners (Oven)	Propane		Natural		Manifold Pressure	
		kcal/h	BTU/h	kcal/h	BTU/h		kcal/h	BTU/h	kcal/h	BTU/h	Propane Gas	Natural Gas
FGR4B	4	25,200	100,000	25,200	100,000	1	6,805	27,000	7,560	30,000	10" W.C	4" W.C

INSTALLATION INSTRUCTIONS

A pressure regulator sized for this unit is included. The gas line connecting to the range must be 3/4" or larger. If flexible connectors are used, the inside diameter must be 3/4" or larger. An adequate ventilation system is required for commercial cooking equipment. Information may be obtained by writing to the National Fire Protection Association, 1 Batterymarch Park, Quincy, MA 02269, www.NFPA.org. When writing, refer to NFPA No. 96.4. These units are manufactured for installation in accordance with ANSZ223.1A (latest edition), National Fuel Gas Code. Copies may be obtained from The American Gas Association, 400 N Capitol St. NW, Washington, DC 20001, www.AGA.org

***NOTE:** In line with its policy to continually improve its product, Fortress™ reserves the right to change materials and specifications without notice. • Specify altitude when above 2,000 feet.