

SECTION II

**Interim Supplemental Specifications
to the
Standard Specifications for Construction and Materials**

This contract shall include by reference the documents known as Supplemental Specifications, the contents of which shall be incorporated in their entirety herein and are in effect for all contracts bid after February 5, 2013:

1. General Conditions Building Projects, last revised March 2010.
2. Addendum 3 to the February 2000 Standard Specifications for Construction and Materials and Standard Details for Construction.
3. #1. and #2. are collectively known as the "Supplemental Specifications."
4. ***Revised General Provisions Pages (19 - 128) and Terms and Conditions (TC) Pages (129 - 141).**

In the event of a conflict between the Supplemental Specifications and the February 2000 Standard Specifications for Construction and Materials and Standard Details for Construction, the Supplemental Specifications shall control.

These documents are subject to change and amendment. It is the responsibility of the parties to this contract to be aware of these Supplemental Specifications. These documents are available for review either (1) at the Department of Public Works, Division of Construction Contracts Administration, County Office Building, Room 300B, 111 West Chesapeake Avenue, Towson, MD, 21204 – Phone (410) 887-3531 or (2) on our website at www.baltimorecountymd.gov/Agencies/publicworks/standardsandspecs/specsanddetails.html

- REVISION to **GP-7.11 Preservation and restoration of Property**, Paragraph (a) of the Standard Specifications Pages 65 and 66.
 - a. The Contractor shall not enter upon public or private property (out-side of the right-of-way or project area) for any purpose without obtaining written permission and he/she shall be responsible for the preservation of all public and private property, trees, monuments, signs and markers and fences thereon, and shall use every precaution necessary to prevent damage or injury thereto. The Contractor shall take suitable precaution to prevent damage to underground or overhead public utility structures. **THE CONTRACTOR SHALL PROTECT CAREFULLY FROM DISTURBANCE OF ALL LAND MONUMENTS AND PROPERTY MARKS LOCATED ON THE CONTRACT DRAWINGS OR FOUND IN THE FIELD. IF DAMAGED OR DISTURBED THEY SHALL BE RESET BY A LICENSED SURVEYOR AT THE CONTRACTORS EXPENSE.**
- REVISION to **GP 7.29 MINORITY BUSINESS ENTERPRISE AND AFFIRMATIVE ACTION** of the Standard Specification Pages 75 to 82 and Pages 10 and 11 of Addendum #3 of the Standard Specifications.
- **GP 7.29.01 County Policy:** It is the policy of the County that MBE's and WBE's, as defined by the most recent County Executive Order and as further described in the Contract Documents, shall have the maximum opportunity to participate in the performance of capital improvement contracts financed by County capital funds and/or County operating funds, in accordance with the most recent County Executive Order. The Contractor shall comply with all MBE/WBE requirements as set forth in the Contract Documents.
- **GP 7.29.02 through 7.29.25:** Superseded by Executive Order Dated June 4, 2009.
- ADDITION to **Section 303.03, Pipe Culvert Construction** of the *Standard Specifications*, Page 227, requiring inspection of interiors of new sewers 12" or larger in diameter with closed circuit TV cameras:

303.03.10 TV Inspection. Contractors shall be required to conduct closed circuit television (CCTV) internal inspections of all new storm drain and culvert construction 12" and larger in diameter or span. This inspection will document and identify any system defects and provide the County with a record of the condition of the storm drain at completion of construction.

The entire length of the pipe shall be shown, and close-up views taken of the entire inner circumference of each pipe joint. Structures occurring along the pipeline shall also be examined on each interior face. Whenever possible, TV inspection shall be done under conditions of minimum or no flow within the pipe system.

The CCTV inspections shall be performed in accordance with *Specification Guidelines: Wastewater Collection Systems Maintenance and Rehabilitation* prepared by the National Association of Sewer Service Companies (NASSCO) and the *Handbook: Sewer Infrastructure Analysis and Rehabilitation*, EPA/625/6-91/030, October, 1991.

The CCTV records, including all logs, photographs and videotape/DVD records, shall be provided to Baltimore County's Bureau of Engineering and Construction, Storm Drain Design Section, for review prior to final acceptance of the construction. Upon approval, the tapes will be forwarded to the Bureau of Utilities for their use.

- ADDITION to Section 1007.03.02, **Acceptance Testing** of the *Standard Specifications*, Page 759, requiring inspection of interiors of new sewers 8" or larger in diameter with closed circuit TV cameras:

(e) **TV Inspection.** Contractors shall be required to conduct closed circuit television (CCTV) internal inspections of all new sewer construction of 8" and larger pipelines. This inspection will document and identify any system defects and provide the County with a record of the condition of the sewer at completion of construction.

The CCTV inspections shall be performed in accordance with *Specification Guidelines: Wastewater Collection Systems Maintenance and Rehabilitation* prepared by the National Association of Sewer Service Companies (NASSCO) and the *Handbook: Sewer Infrastructure Analysis and Rehabilitation*, EPA/625/6-91/030, October, 1991.

The CCTV records, including all logs, photographs and videotape/DVD records, shall be provided to Baltimore County's Bureau of Engineering and Construction, Sewer Design Section, and the Bureau of Utilities for review prior to final acceptance of the construction.

The following changes are made to page 6 of the Consolidated ADDENDUM (#3) to the *Standard Specifications for Construction and Materials* dated February, 2007:

Section GP-2.20 Tie Bids, page 34, (b) Award, last sentence, replace County Code Section in brackets with new numbered reference:

For further options on the bids and the definition of a qualified minority, refer to Baltimore County Code, [Section 15-84(6)] Section 10.2-406(d)(1).

Revise Section 901.01, Aggregates, page 601:

This section covers the material details, quality requirements and test methods applicable to aggregates. Grading requirements are outlined in Tables 901A and 901C; Physical properties in 901 B and 901 D. Force drying may be used in the preparation of samples for grading tests conducted in the field. ***Quarries providing material to Baltimore County Projects must be approved by Maryland State Highway Administration and listed in the current MDSHA Aggregate Bulletin.***

Revise Section 902.10.03, Portland Cement Concrete Mixtures, page 618:

All Portland Cement Concrete mix designs used on Baltimore County projects must have been approved by the Maryland State Highway Administration (MDSHA). The MDSHA mix design approval number must be included on all load tickets. The concrete mixes shall conform to the following:

Revise Section 904.04.02, Mix Design, page 632:

The contractor shall develop a Superpave mix design in conformance with R35. ***All HMA material used on Baltimore County projects must be Maryland State Highway Administration (MDSHA) approved mixes.*** HMA Superpave mixes shall conform to the specification for Superpave Volumetric Mix Design, M323, and shall be designed for Equivalent Single Axle Loading (ESAL) range specified in the Contract Documents.

The contractor may elect to use...

Revise Section 915.01.01, Approval, page 675:

The plant from which the Contractor proposes to obtain material [will be approved by the Regional Engineer before starting deliveries.] ***to be used on Baltimore County projects must have been approved by the Maryland State Highway Administration (MDSHA).***

Rev. 11/09

Revise Section 915.02, HOT MIX ASPHALT (HMA) PLANTS, page 678:

All plants *providing HMA material to Baltimore County projects must be approved by Maryland State Highway Administration (MDSHA) and conform to M 156 except as modified in 915.01 and the following:*

Revise Section 915.03.05, Certified Concrete Plant, page 681:

Concrete plants providing material to Baltimore County Projects must be certified by the Maryland State Highway Administration (MDSHA) and must satisfy all criteria outlined in the Maryland Standard Specifications for Construction and Materials (latest edition). The producer shall be responsible for quality control of plant operations to assure that the material conforms to Specification requirements. The quality control process will be subject to unannounced periodic inspection by representatives of the Regional Engineer. Full participation in the inspection by the plant's certified technician will be required.

The following changes are made to the "Sanitary Sewer Details Index Sheet, Standard Detail S-3, and Roads and Streets Details Index Sheet" of the Consolidated ADDENDUM (#3) to the Standard Details for Construction dated February, 2007.

- 7 D Sanitary Sewer Details Index Sheet
- 7 E Standard Detail S-3
- 7 F Roads and Streets Details Index Sheet

Rev. 11/09

Sanitary Sewer Standard Details

PLATE #	TITLE	SIGNATURE DATE	STD. SPECS. REFERENCE	COMMODITY CODE
S-1	Manhole	3/10/2005	1008	870000
S-2	Shallow Manhole	3/10/2005	1008	872190
S-3	Twin House Conn. Layout	3/18/2002	1007	-
S-4	Precast 48" San.MH	1/2/2007	1008	875000
S-5	60", 72" Precast San. MH	1/2/2007	1008	875000
S-6	Drop MH - Type A & B	3/18/2002	1008	880000, 881000
S-6A	Precast San.Drop MH	12/4/2001	1008	880000, 881000
S-7	Bedding/Gravity PVC Pipe	1/31/2007	1001	-
S-8	Heavy Traffic MH Fr.&Cvr	10/23/1997	1008	877000
S-8B	Sanitary MH Platen Cover – 1	9/12/2000	1008	877000
S-8C	Sanitary MH Platen Cover – 2	9/12/2000	1008	877000
S-12	Stack House Connections	10/23/1997	1007	-
S-12A	House Conn.@ Prop.Line	1/10/2007	1007	-
S-12B	Grinder Pump Conn@Hse.Conn.	1/2/2007	-	-
S-13	Watertight MH Fr.&Cvr	10/23/1997	1008	877000
S-14	Air Relief Valve Vault	3/18/2002	Special Provision	886000
S-15	Precast Doghouse Riser	5/15/2002	1008	-

Rev. 9/09

NOTE: TWIN CONNECTION MAY BE USED ON TOWNHOUSES ONLY.
 ANY OTHER USE MUST BE APPROVED BY THE DIRECTOR
 OF PUBLIC WORKS.

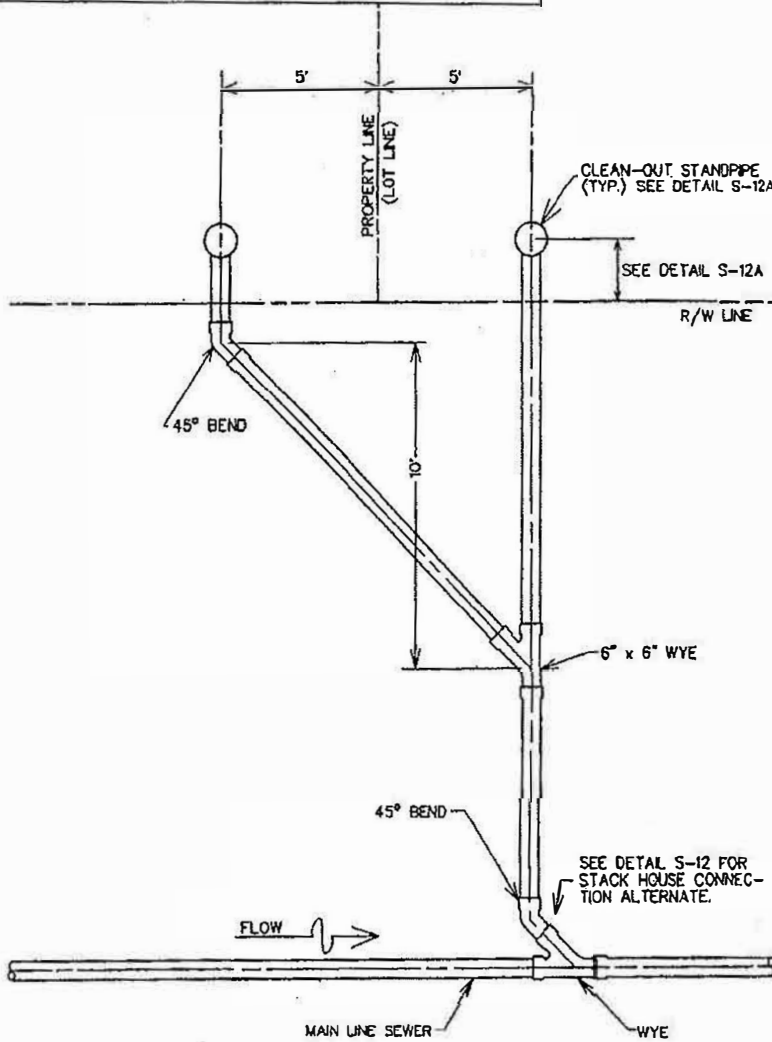

	APPROVAL <i>William J. [Signature]</i> DIRECTOR BUR. OF ENGINEERING & CONSTRUCTION DATE 3/1/82	DEPARTMENT OF PUBLIC WORKS SANITARY SEWER DETAIL TWIN HOUSE CONNECTION LAYOUT	ISSUED: AUGUST, 1977 REVISED: FEBRUARY, 2002 REVISIONS:
			PLATE S-3

* SEE PLATE S-12A & B

LIMIT OF PAYMENT * LIMIT OF PAYMENT

(LF) 6" D.I.P. & FITTINGS OR (LF) 6" P.V.C. W/ ADAPTOR
(LF) 6" D.I.P. & FITTINGS OR (LF) 6" P.V.C. W/ ADAPTOR

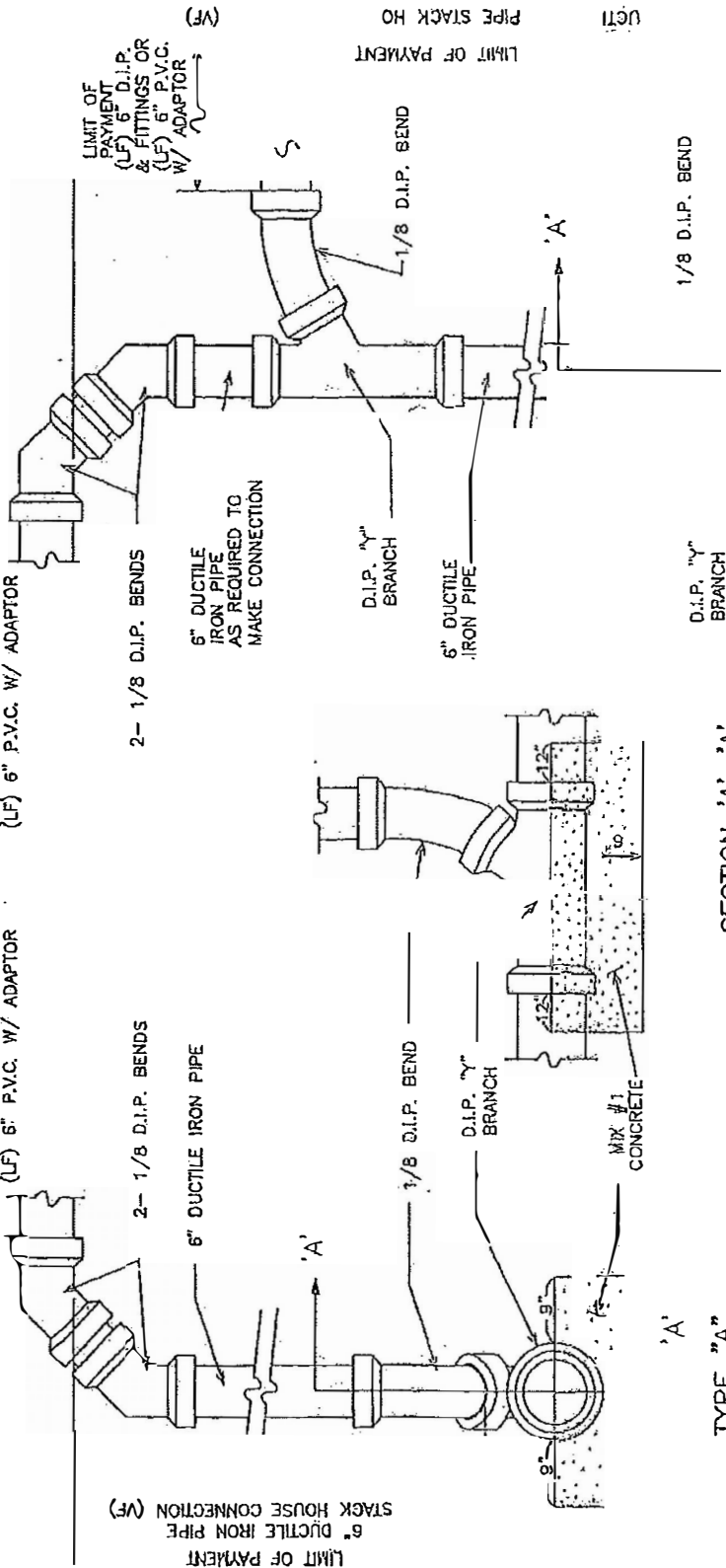

SECTION 'A'-'A'
N.T.S.

NOTES:

1. USE ALL DUCTILE IRON FITTINGS INCLUDING SEWER WYE.
2. TRENCH WIDTH PAYMENT SHALL BE PAID FROM CENTER LINE OF MAIN LINE TO END OF HOUSE CONNECTION. SEE DETAIL G-6 FOR TRENCH WIDTH.
3. MAIN LINE TO BE DUCTILE IRON PIPE.
4. STACK MUST REMAIN PLUMB DURING BACKFILL.
5. NO STACK CONNECTIONS TO BE BUILT ON VCP OR PVC MAIN.



TYPE "B"

APPROVAL	DATE
<i>[Signature]</i>	10/31/12
DIRECTOR	
BUREAU OF ENGINEERING/CONSTRUCTION	

DEPARTMENT OF PUBLIC WORKS
SANITARY SEWER DETAILS
STACK HOUSE CONNECTIONS

ISSUED: OCTOBER 1927
REVISED: AUGUST 1927
REVISED: JUNE 2013
REVISED: MAY 2, 2014
PLATE

S-12

CAMPRESSION Assembly



PRELIMINARY
 Submittal Number
 NPT14-954A
 Design Features
 -Materials
 Frame
 Gray Iron (CI.35B)
 Cover
 Ductile iron (70-50-05)

-Design Load
 Heavy Duty
 -Oper. Area
 n/a
 -Coating
 Unclipped
 -√ Designates Machined Surface

Certification
 -ASTM A49
 -ASTM A536
 -Country of Origin: USA
 Major Components
 WT:42339011
 WT:42339016

Drawing Revision
 2/10/2014 Designer: M:14
 Revised By:

Disclaimer:
 Weights (if any), dimensions (mechanical and drawing) provided for your guidance. We are not liable for any errors or omissions without prior notice.
 COPYRIGHT: This drawing is the property of E.J. Conner, Inc. and shall not be reproduced, stored in a retrieval system, or transmitted in any form or by any means, electronic, mechanical, photocopying, recording, or by any information storage and retrieval system, without the prior written permission of E.J. Conner, Inc.

Contact:
 P.O. Box 4853
 Elgin, VA 22120

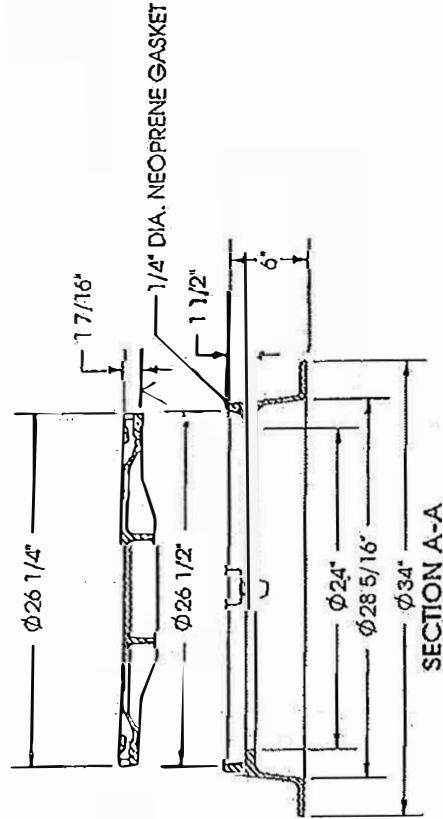
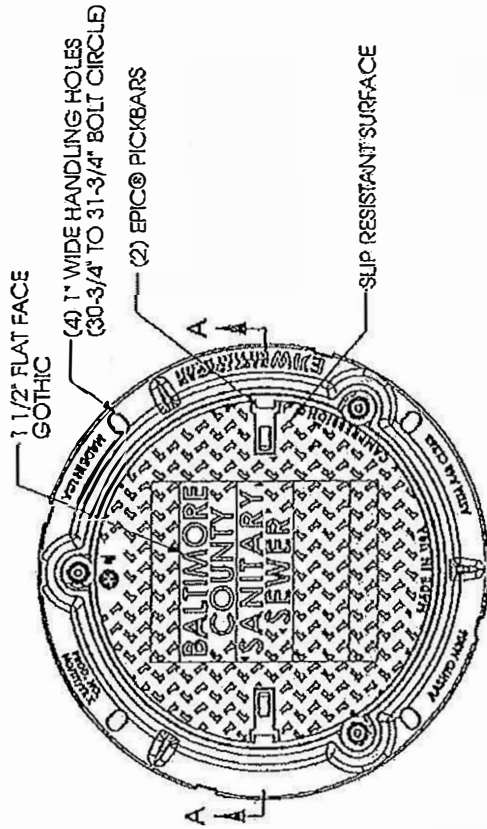

For outside of roadway use.
 Or Approved Equal.
 Supersedes Detail S-13

Roads and Streets Standard Details

PLATE #	TITLE	SIGNATURE DATE	STD. SPECS. REFERENCE	COMMODITY CODE
R-1	Pri.Rd.Paving Sections	11/21/2000	501, 504	-
R-2A	Subdiv.Paving Sect.(CBR≥5)	3/10/2005	501, 504	-
R-2B	Subdiv.Paving Sect.(CBR<5)	3/10/2005	501, 504	-
R-10	20'St.(40'R/W)-No Pkg.	10/23/1997	-	-
R-11	22'St.(40'R/W)-No Pkg.	10/23/1997	-	-
R-12	28'St.(50'R/W)-Pkg.1 Side	11/24/1999	-	-
R-13	30'St.(50'R/W)-Pkg.1 Side	11/24/1999	-	-
R-14	Concrete Alleys	2/22/2006	520	581100
R-14A	Concrete Alleys	11/24/1999	520	387404, 387120, 390500
R-15	Drive Entr.-No Curb	10/23/1997	501, 504	520114, 530300
R-15A	Drive Entr.-Sdwk/Curb Var	2/22/2006	520	581100
R-15B	Drive Entr.-SdwkAbutsCurb	2/22/2006	520	581100
R-17	Concrete Alley Joints	11/24/1999	520	581100
R-18	Alley Entrance	2/22/2006	520	581100
R-19	Std.4'Sidewalk	2/22/2006	610	655000
R-20A	H.M.A. Mountable Curb	11/24/1999	609,03.02	615581
R-20B	Extr.Conc.Mount.Curb	10/23/1997	609	615581, 2
R-21	7"Comb.Curb & Gutter	2/22/2006	609	630000, 616000
R-22	Underdrain-Paved Streets	12/4/2001	305	387000, 390500
R-23	Conc.Ditch to Curb & Gtr	2/22/2006	609, 307	631000, 630000
R-24	Concrete Curb	12/20/2002	-	-
R-27	Barricades	10/23/1997	612, 918	659000
R-28	Svce.Station Entr.Chnliz	2/22/2006	520	-
R-29	Svce.Sta.Entr.@Intersect	2/22/2006	520	-
R-30	Commercial Entr.Chnliztn	2/22/2006	520	-
R-31	Comm.Entr.@Intersection	2/22/2006	520	-
R-32	Single Commercial Entr	1/2/2007	520	-
R-32A	Rural Commercial Entr	10/23/1997	501, 504, 303	-
R-33	Valley Gutter-90DegInter.	1/2/2007	520	631010
R-35	Accel.Lane(Min.Widening)	10/23/1997	-	-
R-35A	Accel.Lane(Widened to PL)	10/23/1997	-	-
R-36A	Ped.Ramp/Median/Depressed	12/20/2002	-	-
R-36B	Truncated Pedestrian Ramp	12/20/2002	-	-
R-36C	Detectable Warnings	12/20/2002	-	-
R-36D	Median/Island Ped.Passage	12/20/2002	-	-
R-36E	Pedestrian Bump-Out	12/20/2002	-	-
R-37	7"Valley Gutter/Perp.Pkg	2/22/2006	520	631010
R-38	Flexible Pvg.of Trenches	3/18/2002	505	120550, 81, 83
R-39	Adjusting Utility Frame	10/23/1997	305, 508	590110, 20
R-41	Pavement Failure Repairs	11/24/1999	605	590600, 5
R-42	Hot-Mix Asphalt Paving	10/23/1997	504	556380

**REPAVING QUANTITIES
SHOWN IN TONS PER LINEAR FOOT**

Graded Aggregate Base = 150 Lb./Cu.Ft.

Hot Mix Asphalt = 160 Lb./Cu.Ft.

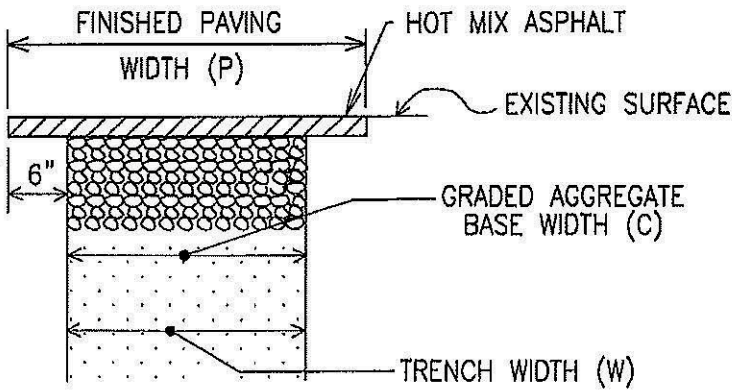

PIPE DIAMETER (INCHES)	12 INCH GRADED * AGGREGATE BASE (TONS / LINEAR FOOT)	2 INCH HOT MIX * ASPHALT PAVING (TONS / LINEAR FOOT)	3 INCH HOT MIX ** ASPHALT PAVING (TONS / LINEAR FOOT)
6"	0.225	0.04	0.08
8"	0.225	0.04	0.08
10"	0.225	0.04	0.08
12"	0.225	0.04	0.08
15" & 16"	0.225	0.04	0.08
18"	0.263	0.047	0.09
20" & 21"	0.263	0.047	0.09
24"	0.30	0.053	0.10
27"	0.375	0.067	0.12
30"	0.375	0.067	0.12
33"	0.413	0.073	0.13
36"	0.413	0.073	0.13
42"	0.488	0.087	0.15
48"	0.525	0.093	0.16
54"	0.60	0.107	0.18
60"	0.638	0.113	0.19
66"	0.675	0.12	0.20
72"	0.75	0.133	0.22
78"	0.825	0.147	0.24
84"	0.863	0.153	0.25
90"	0.90	0.16	0.26
102"	0.975	0.173	0.28
108"	1.05	0.187	0.30
BRACING ADDITIVES			
SINGLE TIER	ADD 0.15	ADD 0.027	ADD 0.04
DOUBLE TIER	ADD 0.30	ADD 0.053	ADD 0.08

* BASED ON TRENCH WIDTH (W)

** BASED ON FINISHED PAVING WIDTH (P)



APPROVAL
[Signature]
DIRECTOR
[Signature]
BUR. OF ENGINEERING/CONSTRUCTION
10/13/17
DATE

DEPARTMENT OF PUBLIC WORKS
GENERAL DETAILS
**PAYMENT QUANTITIES FOR
REPAVING TRENCHES**

ISSUED: OCTOBER, 2017
PREVIOUS
REVISION: AUGUST, 1997

PLATE
G-7

1001.05 STEEL PLATES

If the Contractor elects to bridge a trench or open cut excavation within paved areas of the Construction area with steel plates, it shall notify the Engineer forty-eight (48) hours in advance of placement of any steel plate(s). If multiple plate(s) are required to cover an open cut excavation, the Contractor shall also submit a detailed plan to the Engineer showing the placement of all steel plate(s), as well as any support system required, and this detailed plan shall be approved by the Engineer prior to any installation or use of steel plate(s) by the Contractor. If deemed necessary by the County, this plan may need to be sealed by a professional engineer, licensed in the State of Maryland.

The Contractor shall place proper signs at the locations of all steel plate(s) and such signs shall conform to MUTCD specifications. Spacing of any signs shall be determined by the field conditions and shall be approved by the Engineer.

All steel plates must be flat, at least one inch (1") thick, and held in place with pins. Steel plate(s) must be large enough to allow a minimum of one foot (1') of bearing on three (3) sides of the trench or open cut excavation. Steel plate(s) are to be set as flush as possible with the road surface so there is no movement of the steel plate(s) when traversed by vehicles.

Bituminous concrete cold mix must be used on all edges of the steel plate(s) to minimize the hazard to the motoring public. Cold mix must be tapered from the height of the steel plate(s) to the existing road surface to provide a smooth transition for traveling vehicles.

If the steel plate(s) are to be left in any roadway longer than seven (7) calendar days, the steel plate(s) must be recessed as to be flush with the riding surface.

The Contractor must provide the Engineer with at least two (2) contact persons and corresponding phone numbers to respond to any emergencies or problems with any steel plate(s) and/or support system. Should an emergency or problem occur that requires immediate action, County forces shall correct such emergency or problem, and the County shall charge the Contractor for any costs incurred by the County.

Steel plates are considered incidental to any Contract Construction and/or Work. No County payment shall be made to the Contractor for the use or installation of any steel plate(s) or support system, or for any additional permanent or temporary trench repair required by the County.

**The new General Provisions (GP)
and Terms and Conditions (TC)
supersedes the Standard
Specifications dated February
2000 and Addendums**

GENERAL PROVISIONS

GP - SECTION 1 DEFINITIONS AND TERMS

GP-1.01 GENERAL

This volume is based on the Maryland Department of Transportation, State Highway Administration Standard Specifications for Construction and Materials dated July 2008, as amended in this volume. It has been prepared as the Manual of Standard Specifications under the authority of Section 32-4-404 of the Baltimore County Code, 2003, as amended from time to time.

Baltimore County has adopted a set of Standard Detail Drawings as its Manual of Standard Details that is published separately under the authority of Section 32-4-404 of the Baltimore County Code, 2003, as amended from time to time.

GP-1.02 ORGANIZATIONAL STRUCTURE

Reference to Specifications or procedures beginning with the letters M, R, or T shall be understood to be AASHTO.

Reference to Specifications or procedures beginning with the letters A, B, C, D, E, F, G, ES or P shall be understood to be ASTM.

GP-1.03 LANGUAGE

It shall be understood that when all such expressions such as “directed, specified, authorized, permitted, approval, acceptable or satisfactory” are used they are implicitly followed by the words “by the Engineer” or “to the Engineer”.

GP-1.04 ABBREVIATIONS

Wherever in these General Provisions or in other Contract Documents the following abbreviations are used, the meaning shall be as follows:

AAN	American Association of Nurserymen
AAPA	American Association of Port Authorities
AAR	Association of American Railroads
AASHTO	American Association of State Highway and Transportation Officials
ACI	American Concrete Institute
AIA	American Institute of Architects

Revised
September 19, 2016

AIEE	American Institute of Electrical Engineers
AISC	American Institute of Steel Construction
AISI	American Iron and Steel Institute
ANSI	American National Standards Institute
ARA	American Railway Association
AREA	American Railway Engineering Association
ASCE	American Society of Civil Engineers
ASHRAE	American Society of Heating, Refrigeration and Air-Conditioning Engineers
ASLA	American Society of Landscape Architects
ASME	American Society of Mechanical Engineers
ASTM	American Society for Testing and Materials
ATA	American Transit Association
AWWA	American Water Works Association
AWS	American Welding Society
AWPA	American Wood Preservers Association
AWG	American Wire Gauge
AGC	Associated General Contractors of America
bccmp	bituminous-coated corrugated metal pipe
bccmpa	bituminous-coated corrugated metal pipe arch
B&S	Brown & Sharpe Wire Gauge
BOCA	Building Officials Code Administrators International
cip	cast iron pipe
cipx	cast iron soil pipe, extra strength
cmp	corrugated metal pipe
CPVC	Chlorinated Poly Vinyl Chloride
CSPA	Clay Sewer Pipe Association
COMAR	Code of Maryland Regulations
CRSI	Concrete Reinforcing Steel Institute
dip	ductile iron pipe
DIPRA	Ductile Iron Pipe Research Association
EI	Edison Electric Institute
EIA	Electronic Industries Association
EPA	Environmental Protection Agency
FAA	Federal Aviation Administration, U.S. Department of Transportation
FCC	Federal Communications Commission
FHWA	Federal Highway Administration, U.S. Department of Transportation
FRA	Federal Railway Administration, U.S. Department of Transportation
FSS	Federal Specifications and Standards, General Services Administration
FTA	Federal Transit Administration
IEEE	Institute of Electrical and Electronic Engineers
IES	Illuminating Engineers Society
IMSA	International Municipal Signal Association
IPCEA	Insulated Power Cable Engineers Association
IRT	Institute for Rapid Transit
MBE	Minority Business Enterprise
MBMA	Metal Building Manufacturers Association

MDOT	Maryland Department of Transportation
MSMT	Maryland Standard Method of Tests (as developed by the State Highway Administration)
MUTCD	Manual on Uniform Traffic Control Devices
MdMUTCD	Maryland Manual on Uniform Traffic Control Devices
MdSHA	Maryland State Highway Administration
NBFU	National Board of Fire Underwriters
NBS	National Bureau of Standards
NCHRP	National Cooperative Highway Research Program
NEC	National Electric Code
NESC	National Electric Safety Code
NEMA	National Electrical Manufacturers Association
NFPA	National Fire Protection Association
NIST	National Institute of Standards and Technology
OSHA	Occupational Safety and Health Administration
PCA	Portland Cement Association
pccp	prestressed concrete cylinder pipe
PCI	Precast Concrete Institute
PVC	Poly Vinyl Chloride
QPL	Qualified Products List
rccp	reinforced concrete culvert pipe
rcsp	reinforced concrete sewer pipe
RLMI	Reflector and Lamp Manufacturers' Institute
RMA	Rubber Manufacturers Association
SAE	Society of Automotive Engineers
SAWP	Society of American Wood Preservers
SHA	State Highway Administration
SSPC	Steel Structures Painting Council
ucpx	unglazed clay pipe, extra strength
UL or ULI	Underwriters Laboratories, Incorporated
UMTA	Urban Mass Transportation Administration, U.S. Department of Transportation
USSG	United States Standard Gauge
USSWG	United States Steel Wire Gauge
WBE	Women's Business Enterprise

GP-1.05 DEFINITIONS

Wherever in these General Provisions or in other Contract Documents the following terms are used, the meaning shall be as follows:

Additional Work - Work not required or provided for in the original Contract.

Administration - Baltimore County, Maryland, a body corporate and politic.

Administrator - The Director of the Department.

Advertisement - The public announcement, as required by law, inviting any and all prequalified contractors to submit a Bid for Work to be performed or provided.

Agreement - The written agreement executed between the County and the successful Bidder covering the performance of the Work by which the Contractor is bound to perform the Work and by which the County is obligated to compensate the Contractor therefor at a mutually established and accepted rate or price. The Agreement shall include all the documents listed under "Contract Documents", as well as any written Contract Modification that is required to complete the Construction and completion of the Work in an acceptable manner, including any authorized extension thereof, all of which constitute one instrument and agreement. The Agreement shall be executed by the Contractor and the County as indicated by the signature of the Contractor's duly and legally authorized representative and the County Executive or his/her legally authorized designee, with evidence thereof of review for legal sufficiency by the County's Office of Law.

Alley - An established passageway for vehicles and pedestrians affording a secondary means of access in the rear to properties abutting on a street or Highway.

Approved Source of Supply - Listing prepared by the Department on a periodic basis and available on the Department's website.

Architect and/or Design Engineer - The Maryland licensed and registered architect and/or design engineer under separate contract with the County to prepare the Plans and Contract Documents.

As-Built Drawings - A complete set of sealed and signed as-built Mylar record Contract Drawings that are based on the marked-up prints or red-lined drawings received from the applicable contractor, the shop drawings, any addenda, any change orders, any requests for information, and any other data utilized by the Contractor so as to provide a complete and accurate as-built record.

Award - The decision and notice given by the County of the acceptance of a Bid or Proposal. The successful Bidder understands and expects the County to substantially, materially and justifiably rely upon its Bid from the date of Award pending execution of the Agreement.

Baltimore County - Baltimore County, Maryland, a body corporate and politic.

Base Course - The one or more layers of specified material and thickness placed on a Subbase or a Subgrade to support a Surface Course.

Bid - A written submission including, but not limited to, price, terms of sale, and description of work technical expertise, work experience, and any other information requested in the Bid Package, offered by a Bidder to the County in response to the County's Bid Package or request for Proposal.

Bid Bond - The security required and described in the Bid Package and GP-2.07 to be included in the Proposal and furnished by the Bidder as a guaranty of good faith to enter into a Contract with the County if the Work is Awarded to the Bidder.

Bid Form - The approved form included in the Bid Package and/or Proposal Form, on which the Administration requires the Bid to be set forth and submitted.

Bid Item - An item of Work specifically described and for which a price, either unit or lump sum, is required. It includes the performance of all Work described herein or described in any Supplemental Specifications or Special Provisions.

Bid Package – Includes, but is not limited to, the Standard Specifications and any Contract Document included and/or incorporated by reference therein, used by the County for soliciting and procuring Bids by competitive sealed Bid and/or requests for Proposals and/or small procurement procedures including, but not limited to, requests for quotations, requests for Bids, etc.

Bidder - A Person formally submitting a Bid for the Work, acting directly or through a duly and legally authorized representative.

Bridge - A structure including supports erected over a depression or an obstruction, such as water, Highway, or railway, and having a track or passageway for carrying traffic or other moving loads, and having an opening measured along the center of the Road of more than 20 feet between undercopings of abutments or spring lines of arches, or extreme ends of openings for multiple boxes; it may also include multiple pipes, where the clear distance between openings is less than half of the smaller contiguous opening. For lengths, all dimensions shall be parallel to the center line of the Road. The dimensions of handrails will not be taken into account in measuring bridge lengths. Any Bridge or Highway grade separation structure includes the connecting Highways, Substructure, Superstructure, Road approaches, entrance plazas, interchanges, overpasses, underpasses, and other Structures which the Administration may deem necessary together with all property rights, Easements, franchises, and interests acquired by the Administration for the Construction and operation of the Bridge.

Business - A corporation, partnership, individual, sole proprietorship, joint venture, or any other legal entity through which commercial activity is conducted.

Business Day - Every day shown on the calendar except Saturdays, Sundays and Holidays.

Calendar Date – The specific calendar date by which Contractor must achieve Full and Final Completion of the Work and all requirements under the Contract.

Calendar Day - Every day shown on the calendar, Saturdays, Sundays and Holidays included.

Certification - A document which states that the Material and/or Work complies with the applicable specifications and includes the actual test results to confirm the statement. The contents of the Certification shall be on the contractor's/vendor's/manufacture's letterhead or

approved document and shall be duly signed by a legally and duly authorized officer. Certifications for metal products, when required, shall include a statement that the metal product was melted and manufactured in the United States.

Change Order - A written order amending the Contract and signed by the responsible Engineer, authorizing and requiring changes to the original Contract, with or without the consent of the Contractor. Each Change Order shall be executed by the Contractor and the County as indicated by the signature of the Contractor's duly and legally authorized representative and the County Executive or his/her legally authorized designee, with evidence thereof of review for legal sufficiency by the County's Office of Law.

Completion Date - The number of Working Days, Calendar Days, or Calendar Date shown in the Contract indicating the time allowed for the Full and Final Completion of the Work contemplated in the Contract.

Construction – To build, alter, Repair, improve and/or demolish any structure, building, or other improvement to real property and/or fixtures.

Construction Strip - An area contiguous to a permanent fee area or Easement, temporarily acquired for the use of the Contractor during the execution of the Work. This area exists only when shown on the Plans.

Contingent Item - Any Bid Item listed in the Contract Documents and included in the Bid for the purpose of obtaining a Contract price. Such Bid Item(s) constitutes tender of an exercisable option to and for the benefit of the County to incorporate such Bid Item(s) into the Work in accordance with the stated Bid prices.

Contract - The written agreement executed between the County and the successful Bidder covering the performance of the Work by which the Contractor is bound to perform the Work and by which the County is obligated to compensate the Contractor therefor at a mutually established and accepted rate or price. The Contract shall include all the documents listed under "Contract Documents", as well as any written Contract Modification that is required to complete the Construction and completion of the Work in an acceptable manner, including any authorized extension thereof, all of which constitute one instrument and agreement. The Contract shall be executed by the Contractor and the County as indicated by the signature of the Contractor's duly and legally authorized representative and the County Executive or his/her legally authorized designee, with evidence thereof of review for legal sufficiency by the County's Office of Law.

Contract Bond – Means Bid Bond, Payment Bond, Performance Bond and/or Proposal Guaranty, as applicable.

Contract Documents - The Contract executed between the Administration and the successful Bidder, covering the performance of the Work by which the Contractor is bound to perform the Work, and by which the Administration is obligated to compensate Contractor therefor at the mutually established and accepted rate or price. The Contract Documents shall include, but not be limited to, the Bid Package (which includes, but is not limited to, the instructions to bidders

document, the information for bidders document and the specifications), Extra Work Order, Proposal Form, Proposal, Contract Bond, General Provisions, Contract Drawings, Special Provisions, Technical Provisions, all Plans and Notices to Proceed, also any Change Order, Contract Modification and Supplemental Agreement that are required to complete the Work in an acceptable manner, including County-authorized extensions of time for completion thereof, the Award, and the Agreement.

Contract Drawings - The official drawings issued by the Administration as part of the Contract Documents, including those incorporated in the Contract Documents by reference.

Contract Item or Pay Item - An item of Work specifically described and for which a price, either unit or lump sum, was provided in the form of a County-approved Bid Item and incorporated into the Contract, unless expressly stated to the contrary by the County. It includes the performance of all Work described therein.

Contract Modification - Any written change to the Contract including, but not limited to, delivery point, date of delivery, Contract period, price, quantity, or other provision of any original and/or existing Contract, whether accomplished in accordance with a Contract provision, or by mutual written action of legally and duly authorized representatives of the parties to the Contract including, but not limited to, any Change Order, Extra Work Order, Supplemental Agreement, and/or other form of Contract Modification. Each Contract Modification shall be executed by the Contractor and the County as indicated by the signature of the Contractor's duly and legally authorized representative and the County Executive or his/her legally authorized designee, with evidence thereof of review for legal sufficiency by the County's Office of Law.

Contract Number - The eight-place combination of numerals and letters by which all Contracts are identified:

9 6 0 0 0 X X 0

The first two digits indicate the year. The next three digits indicate the sequential numbering; the first Contract of each year is numbered 001, the second Contract 002 etc., regardless of the division of the Contract.

The three-space alpha-numeric combination (X X 0 above) indicates the general nature of the Work and the division of the Contract for accounting purposes. The two letters (X X) indicate the general nature of the Work. The last digit indicates the numerical division of the Contract. A zero as the last digit indicates that the Contract will be accounted as a whole.

GENERAL NATURE OF THE WORK

First X	Second X
B - Bridge	D - Development (Public)
C - Culvert	F - Fire Station
D - Storm Drain	L - Library
G - Grading or miscellaneous	

- | | |
|--|--|
| P - Public Building | O - Operating Building |
| R - Road
(except when used with RA,
indicates Right-of-Way
Improvement) | P - Police Station |
| S - Sewer | X - Capital Improvement |
| W - Water | S - Development (Private
other than UA or RA) |
| U - Utility | A - Agreement (for Private UA and RA) |

Contract Time - The number of Working Days, Calendar Days, or a Calendar Date specified in the Contract Documents indicating the time period allowed for the Full and Final Completion of the Contract Work.

Contractor - The party of the second part to the Contract; the Person undertaking the execution of the Work under the terms of the Contract and acting directly or through his, their, or its agents or employees. If the party of the second part is comprised of one or more Persons, each shall be jointly and severally responsible for the performance of the entire Contract and jointly and severally liable to the County.

Controlling Operation - An operation that at the particular time under consideration has a controlling effect on the progress of the project as a whole.

County - Baltimore County, Maryland, a body corporate and politic.

County Roads - Any public Road in the County, excluding State Roads, fee title to which, or Easement for the use of which, is vested in the County by grant of condemnation, dedication, conveyance or by operation of law.

Culvert - Any structure not classified as a Bridge that provides an opening under any Roadway.

Day - Calendar Day unless otherwise designated.

Department - The Department of Public Works of Baltimore County, unless another County department or office is expressly identified and designated by the County.

Domestic Manufacture - When referring to metallic items such as structural steel, pipe, reinforcement, bridge rails, etc., the term Domestic Manufacture means those metal products that have been melted and manufactured within the United States.

Drainage Ditch - In general, any open water course other than gutters, constructed as indicated in the Contract Documents.

Easement - A grant of a) an interest in property and b) a right of use of property of an owner for a certain purpose at the will of the grantee.

Engineer – Unless an official is expressly identified in writing by the County or expressly stated in the Contract Documents, Engineer means any one of the following:

Director of the Department, or his authorized delegated representative,
Deputy Director of the Department (if applicable),
Chief, Division of Construction Contracts Administration of the Department, or
Chief, Bureau of Engineering & Construction of the Department.

Any delegation of the Engineer’s authority must be authorized in writing by any one of the above listed officials or expressly stated in the Contract, and such delegation of authority will pertain only to the specific Contract and/or Contracts as expressly stated in the authorization.

If the Engineer’s authority is delegated as specified above to another County department or office, “Department” shall mean the County department or office delegated such authority, and any references to a director, deputy director, chief, division, or bureau shall mean the corresponding official, employee, division, bureau or office of the County department delegated such authority, as applicable and appropriate; provided that, any references to “Department” rules, lists, or published and/or adopted materials shall continue to refer to the County Department of Public Works.

Equipment - All machinery, tools, and apparatus necessary for the proper Construction and acceptable completion of the Work, together with the necessary supplies for upkeep and maintenance.

Extra Work - Work that was not required or provided for in the original Contract.

Extra Work Order - A written document amending the Contract by adding, deleting, or modifying the Contract to include price, time and/or Extra Work and/or conditions not previously addressed within the Contract. Each Extra Work Order shall be executed by the Contractor and the County as indicated by the signature of the Contractor’s duly and legally authorized representative and the County Executive or his/her legally authorized designee, with evidence thereof of review for legal sufficiency by the County’s Office of Law.

Federal Agencies - Reference to any federal agency or official shall be deemed made to any agency or official succeeding in conformance with law or regulations to the powers, duties, jurisdictions, and authority of the agency or official mentioned.

Final Acceptance for Maintenance - The date upon which all the Work is sufficiently complete in accordance with the Contract so that the County can occupy and utilize the Work for the purposes for which it was intended, and more specifically, the date that the Engineer makes written acceptance of all Work under the Contract for the purpose of the County assuming maintenance responsibilities for all Work, as further described in Section GP-5.13(b) of the Standard Specifications. Final Acceptance for Maintenance will also be considered Substantial Completion for purposes of the Contract and the Work.

Fixed-Price Items - Unit prices established and prescribed by the County to compensate for the cost of Work and Materials that may or may not be necessary for the proper completion of the Contract, and the quantities of which are not amenable to the reliable quantitative estimate prior to Construction. Fixed-Price Items are shown on the Proposal sheets with the estimated quantities, fixed price, and estimated total cost imprinted prior to issuance of the Contract Documents to Bidders.

Full and Final Completion - The date upon which the County acknowledges in writing that the Contractor fully and finally completed all aspects of the Contract and the Contract Work, and met all terms, conditions and obligations of the Contract, as further described in Section GP-8.11 of the Standard Specifications.

General Provisions or GP - Contract provisions published as part of, or provided as a supplement to these Standard Specifications intended for general application and repetitive use.

Highway or Road - Includes rights-of-way, surfaces, Subgrades, Shoulders, Median dividers, drainage facilities and Structures, Road cuts, Road fills, traffic barriers, Bridges, Highway grade elimination Structures, tunnels, overpasses, underpasses, interchanges, entrance plazas, approaches and other Structures forming an integral part of a street, Road, or Highway; including bicycle and walking paths and related storm water management facilities and Structures. In addition, the terms include any other property acquired for the Construction, operation, or use of the Highway.

Highways Standards - Official MdSHA “Book of Standards, Highways and Incidental Structures” edited by the MdSHA with the latest incorporated revisions issued on or before the date of Advertisement of the Contract. These Highway Standards are used where County projects are constructed within MdSHA rights-of-way, or as directed by these Specifications or by the Engineer.

Holidays – Holidays only occur on:

January 1	New Year’s Day
3rd Monday in January	Martin Luther King’s Birthday
3rd Monday in February	President’s Day
4th Monday in May	Memorial Day
July 4	Independence Day
1st Monday in September	Labor Day
2nd Monday in October	Columbus Day
November 11	Veteran’s Day
4th Thursday in November	Thanksgiving Day
December 25	Christmas Day

All days of general and congressional elections (not primary elections) throughout the State.

If a Holiday falls on a Sunday, the following Monday shall be deemed and treated as a Holiday.

If a Holiday falls on a Saturday, the Friday immediately preceding shall be deemed and treated as a Holiday.

Informal Contract - A Private Contract not exceeding twenty-five thousand dollars (\$25,000), subject to the approval of the County's Department of Permits, Approvals and Inspections, bid on a lump sum basis, and not requiring a Contractor Performance Bond or Payment Bond. Informal Contracts may be used for commercial water meters and detector checks two (2) inches and smaller, fire hydrants, sanitary connections, residential water and sewer house connections for four (4) lots or less, and small road and drain projects not exceeding the twenty-five thousand dollars (\$25,000).

Inspector - The authorized representative of the Engineer assigned to make detailed inspection of any or all portions of the Work.

Interim Supplemental Specifications or ISS – Those items required by the Department and the County for all County contracts, which shall be included as part of the Contract Documents and incorporated into the Contract, but which are not formally published in the Standard Specifications. The ISS control over the Standard Specifications but do not control over the Special Provisions.

Laboratory - The testing Laboratory of the State Highway Administration (or other administrations) or any other testing Laboratory designated by the Engineer.

Landscaping (Highway) or Roadside Development - Work for the preservation of natural and landscaped areas and the rehabilitation and protection against erosion of all areas disturbed by Construction through turf establishment and the placing of other ground covers, suitable planting, and other improvements to increase the effectiveness and enhance the appearance of the Highway.

Major Contract Items - The original Contract Items of greatest cost, excluding Contingent Items, (computed from the original price and estimated quantity or lump sum price) plus such other Contract Items next in sequence of lower cost (computed in like manner) as are necessary to show a total cost of original prices and quantities of not less than sixty percent (60%) of the original total cost of the Work, Bid and/or Proposal.

Median - The portion of a divided Highway separating the Traveled Ways for traffic in opposite directions.

Materials - Any substances and/or goods specified for use in the Construction of the Work and its appurtenances.

Minor Contract Items - All Contract Items other than the Major Contract Items and Contingent Items.

Minor Structure - Any structure not classified as a building, Bridge or Culvert. Minor Structures include, but are not limited to, catch basins, fences, inlets, manholes, retaining walls, steps and other miscellaneous items.

Notice to Proceed - A Written Notice to the Contractor of the date on or before which Contractor shall begin the prosecution of the Work to be done under the Contract.

Partial Acceptance for Maintenance - The date upon which the Engineer makes written acceptance of a unit or portion of the Work under the Contract and the County assumes maintenance responsibilities for only that unit or portion of Contract Work, as further described in Section GP-5.13(a) of the Standard Specifications.

Pavement Structure - The surface, base, or Subbase Course placed in layers on a Subgrade to support and distribute the traffic load to the Roadbed.

Pay Item - An item of Work specifically described and for which a price, either unit or lump sum, was provided in the form of a County-approved Bid Item. It includes the performance of all Work described therein.

Payment Bond - A County-approved form of security furnished and executed by the Contractor and Contractor's Surety as a guaranty of good faith to pay promptly, or cause to be paid promptly, in full, such sums as may be due for Material and/or labor supplied or performed, and/or services rendered by third parties in the prosecution of the Work under the Contract. This Payment Bond is in addition to the Performance Bond.

Performance Bond - The County-approved form of security, furnished and executed by the Contractor and Contractor's Surety, guaranteeing Full and Final Completion of the Work in complete compliance with and in accordance with the Contract and all Contract Documents. This Performance Bond is in addition to the Payment Bond.

Person - A corporation, partnership, individual, sole proprietorship, joint venture, or any other legal entity through which commercial activity is conducted.

Plans - The official drawings issued by the Administration as part of the Contract Documents, including, but not limited to, those incorporated in the Contract Documents by reference.

Private Contract - A private contract for Highway, storm drain, water main, utilities, roads, and sanitary sewer Construction let by applicants or Persons, by procedures pursuant to Public Works Agreements with County at no cost to County. The developer, in such a Private Contract, obtains the bid privately using contract forms provided by the Department's Division of Construction Contracts Administration. Private Contracts bearing the letters "UA" or "RA" within their Contract Numbers are governed and initiated by the Baltimore County Department of Permits, Approvals and Inspections Policy for the Construction of Improvements Under Private Contracts, pursuant to Baltimore County Code Section 32-4-301, as amended, and shall be referred to as UA and/or RA, as applicable, in these Standard Specifications.

Procurement Agency - Baltimore County, Maryland, a body corporate and politic.

Profile Grade - The trace of a vertical plane intersecting the top surface of the proposed wearing surface usually along the longitudinal center line of the Road. Profile Grade means either elevation or gradient of the vertical plane.

Proposal – A written submission including, but not limited to, price, terms of sale, and description of work technical expertise, work experience, and any other information requested in the Bid Package, offered by a Bidder to the County in response to the County’s Bid Package or request for Proposal.

Proposal Affidavit – An affidavit form (included in the Invitation for Bid) to be a certified form executed by a legally authorized representative of the Bidder and required to accompany a Bid.

Proposal Form - Includes, but is not limited to, the Standard Specifications and any Contract Document included and/or incorporated by reference therein, used by the County for soliciting and procuring Bids by competitive sealed Bid and/or requests for Proposals and/or small procurement procedures including, but not limited to, requests for quotations, requests for Bids, etc.

Proposal Guaranty - The security required and described in the Bid Package and GP- 2.07 to be included in the Proposal and furnished by the Bidder as a guaranty of good faith to enter into a Contract with the County if the Work is Awarded to said Bidder.

Questionnaire - The approved form or forms upon which the Contractor shall furnish the information as to its ability to perform the Work, its experience in similar Work, the Equipment to be used, and its financial condition as related to its ability to finance the Work.

RA - A private contract for Highway, storm drain, water main, and sanitary sewer Construction is let by land developers, by procedures pursuant to Public Works Agreements with Baltimore County, Maryland. The developer, in such a Contract, obtains the Bid privately using Contract forms provided by the Division of Construction Contracts Administration. Private Contracts bearing the letters “RA” within their Contract Numbers are governed by the Baltimore County Department of Permits, Approvals and Inspections Policy for the Construction of Improvements Under Private Contracts pursuant to Baltimore County Code Section 32-4-301, as amended, and shall be referred to as RA and/or UA Contracts or RA and/or UA in these Standard Specifications.

Ramp - A connecting Road between two intersecting Highways at a Highway separation.

Regional Engineer - Unless an official is expressly identified in writing by the County or expressly stated in the Contract Documents, Regional Engineer means any one of the following:

Director of the Department, or his authorized delegated representative,
Deputy Director of the Department (if applicable),
Chief, Division of Construction Contracts Administration of the Department, or

Chief, Bureau of Engineering & Construction of the Department.

Any delegation of the Regional Engineer's authority must be authorized in writing by any one of the above listed officials or expressly stated in the Contract, and such delegation of authority will pertain only to the specific Contract and/or Contracts as expressly stated in the authorization.

If the Regional Engineer's authority is delegated as specified above to another County department or office, "Department" shall mean the County department or office delegated such authority, and any references to a director, deputy director, chief, division, or bureau shall mean the corresponding official, employee, division, bureau or office of the County department delegated such authority, as applicable and appropriate; provided that, any references to "Department" rules, lists, or published and/or adopted materials shall continue to refer to the County Department of Public Works.

Repair - To restore after injury, deterioration, or wear; to mend, to renovate, by such means as appropriate, and to supply such Materials and labor as necessary to render the item to be repaired sound, solid, true, plumb, square, even, smooth, and fully serviceable. Upon completion of such repair it must be, unless otherwise stated, rendered to such condition as to present a first-class finished work, or in instances where the repaired item serves as a base for additional finish, the repaired work must be such as to permit a first-class finish, to be applied without extra cost to the County. When the word "Repair" is used in connection with machinery or mechanical Equipment, it shall mean, in addition to the above, rendering the Equipment completely serviceable and efficient, ready for the normal use for which it was originally intended.

Responsible Bidder - A Person who is a Prequalified Contractor, as further described in these Standard Specifications and pursuant to the County's Rules for Prequalification of Contractors, as described in GP-2.00 of these Standard Specifications, and who has the capability in all respects to perform fully the Contract requirements and to perform all mandatory and essential requirements of the Bid, and the integrity and reliability that shall assure good faith performance.

Responsive Bid - A Bid submitted in response to a Bid Package that conforms in all material respects to all requirements contained in the Bid Package, including, but not limited to, all mandatory and essential requirements of the Bid.

Responsive Bidder - A Responsible Bidder whose Bid conforms in all material respects to the Bid Package, including, but not limited to, all mandatory and essential requirements of the Bid.

Right-of-Way - The area that has been acquired and reserved by the County for use in constructing the proposed improvement and appurtenances thereto. The area may be held by the County for use in constructing the proposed improvements and appurtenances thereto. The area may be held by the County in fee simple or as an Easement -- perpetual or temporary, recorded or unrecorded.

Roadbed - The graded portion of a Highway within the top and side Slopes prepared as a foundation and/or the top surface of a Road upon which the Pavement Structure, Shoulders, and curbs are constructed.

Road, Roadway or Highway - The words Road, Roadway and Highway include rights-of-way, surfaces, Subgrades, Shoulders, Median dividers, drainage facilities and Structures, Roadway cuts, Roadway fills, traffic barriers, Bridges, Highway grade elimination Structures, tunnels, overpasses, underpasses, interchanges, entrance plazas, approaches, and other Structures forming an integral part of a street, Road, Roadway, or Highway; including bicycle and walking paths and related storm water management facilities and Structures. Any other property acquired for the Construction, operation, or use of the Highway.

Roadside - A general term denoting the area adjoining the outer edge of the Roadbed within the Right-of-Way. Extensive areas between the Road of a divided Highway may also be considered Roadside.

Roadside Development - Work for the preservation of natural and landscaped areas and the rehabilitation and protection against erosion of all areas disturbed by Construction through turf establishment and the placing of other ground covers, suitable planting, and other improvements to increase the effectiveness and enhance the appearance of the Highway.

Seal Coat - An application of asphalt material followed by an application of cover coat aggregate.

Shoulder - The portion of the Roadbed contiguous with the Traveled Way for accommodation of stopped vehicles, for emergency use, and for lateral support of base and Surface Courses.

Sidewalk - The portion of the Road constructed for use by pedestrians.

Slopes - The inclined graded areas beyond the Shoulder, extending from the Shoulders to the natural, undisturbed surface of the ground.

Special Provisions or SP - Specifications for a specific item or condition or requirement peculiar to the Work and not otherwise thoroughly or satisfactorily detailed elsewhere in the Contract Documents. If a Special Provision or SP is in conflict with any portion of the Contract Documents, the Special Provisions shall always control and prevail. Specifically, the Special Provisions control over the Standard Specifications and the Interim Supplemental Specifications.

Standard Details / Standard Detail Drawings / Baltimore County Standard Details for Construction - The Baltimore County, Maryland Department of Public Works Standard Details for Construction published by the Administration for general application and repetitive usage, as may be supplemented, revised and superseded by the Contract Documents, which include detail drawings showing standard methods of Construction for water mains, sanitary sewers, storm drains, roads and streets.

Standard Specifications - The Baltimore County Department of Public Works Standard Specifications for Construction and Materials published by the Administration for general application and repetitive use, as may be supplemented, revised and superseded by the Contract Documents.

State - The State of Maryland.

State Agency - A State agency or official thereof, including any agency or official succeeding to their powers, duties, jurisdictions and authority in accordance with law.

State Highway System - The system of Roads owned, operated, or maintained by the State of Maryland.

State Road - Any public Road included in the Maryland State Highway System.

Structure(s) - Bridges, culverts, catch basins, drop inlets, retaining walls, cribbing, manholes, end walls, buildings, sewers, service pipes, underdrains, foundation drains, steps, fences, and other features that may be encountered in the Work and not otherwise classified.

Subbase - The layers of specified or selected material of designed thickness placed on a Subgrade to support a Base Course or Surface Course.

Subcontract - Any agreement entered into by the Contractor with a Subcontractor for a portion of the Construction or any other part of the Work in connection with, and under the terms of, the Contract.

Subcontractor - Any Person undertaking a portion of the Construction or any other part of the Work under the terms of the Contract, by virtue of an agreement with the Contractor. Subcontractor does not include an employee with an employment contract, or an employee organization with a collective bargaining agreement. It includes one who furnished Material worked to a special design according to the Plans and Specifications for the Work. It excludes one who merely furnished Material not so worked.

Subgrade (Highways) - The top surface of a Roadbed upon which the Pavement Structure, Shoulders, and curbs are constructed.

Subgrade (Pipes) - The soil foundation layer upon which a pipe, cradle, or encasement is placed such that the prescribed invert elevation of the pipe will be achieved.

Subgrade (Structures) - The soil foundation layer upon which the structural foundation is built to achieve prescribed elevations of subsequent structural elements or controls.

Substantial Completion / substantial completion - The date upon which all the Work is sufficiently complete in accordance with the Contract so that the County can occupy and utilize the Work for the purposes for which it was intended, and more specifically, the date that the Engineer makes written acceptance of all Work under the Contract for the purpose of the County assuming maintenance responsibilities for all Work, as further described in Section GP-5.13(b) of the Standard Specifications. Substantial Completion will also be considered Final Acceptance for Maintenance for purposes of the Contract and the Work.

Substructure - All of that part of the Structure below bottoms of bearings of simple and continuous spans, skewbacks of arches and tops of footings of rigid frames, together with the back walls and wing walls.

Superintendent - The executive representative of the Contractor duly authorized by the Contractor, in accordance with Contractor's organizational documents and requirements to receive and execute instructions from the Engineer, and who shall supervise and direct the Construction and the Work.

Superstructure - All of that part of the Structure above bottoms of bearings of simple and continuous spans, skewbacks of arches and tops of footings of rigid frames, except as noted above for Substructure.

Supplemental Agreement - Any written Contract Modification or Change Order evidencing, among other things, the terms, conditions, costs and time, mutually agreeable to the Contractor and the County as indicated by the signature of the Contractor's duly and legally authorized representative and the County Executive or his/her legally authorized designee, with evidence of review for legal sufficiency by the County's Office of Law.

Surety - The Person providing any or all of the Contract Bonds for the Contractor, for the Bid and the Full and Final Completion of the Contract and/or for the payment for all of the Work in connection with the Contract.

Surface Course - One or more layers of a pavement designed to accommodate direct traffic loading.

Technical Provisions - The technical provisions included in the Proposal Form and/or Invitation for Bid, which are a part of and incorporated into the Contract.

Third Tier Contracting - The process where the Contractor subcontracts a portion of the Contract to a Subcontractor who in turn subcontracts a portion of the Contract to a third party. This latter action is termed entering into a Third Tier Contract.

Traveled Way - The portion of the Roadway for the movement of vehicles, exclusive of Shoulders.

Trench - An excavation made for the purpose of installing or removing pipes, drains, catch basins, etc., which is later refilled.

UA - A private contract for Highway, storm drain, water main, and sanitary sewer Construction is let by land developers, by procedures pursuant to Public Works Agreements with Baltimore County. The developer, in such a Private Contract, obtains the bid privately using contract forms provided by the Department's Division of Construction Contracts Administration. Private Contracts bearing the letters "UA" within their Contract Numbers are governed by the Baltimore County Department of Permits, Approvals and Inspections Policy for the Construction of

Improvements Under Private Contracts, pursuant to Baltimore County Code Section 32-4-301, as amended, and shall be referred to as UA and/or RA Contracts or UA and/or RA in these Standard Specifications.

Unclassified Excavation - Excavation not defined within Standard Specifications' classifications, including, but not limited to, rock, logs, stumps, water, debris. (Excavation of all utility Trenches to subgrade.)

Utility Agreements/Right-of-Way Agreements or UA/RA- These UA/RA are initiated in the County Department of Permits, Approvals and Inspections (PAI), or any successor County department, by the applicant, including, but not limited to developers, schools, or commercial property owners for the Construction and installation of improvements to utilities or roads at no cost to the County. PAI reviews and approves, if and as applicable, the cost estimates, Construction drawings, UA and/or RA, as applicable, and collects any security and fees.

Utility Companies – Entities or Persons which may have utility facilities in a proposed Work area (e.g. BG&E and Verizon, etc.)

Work – The Contractor's furnishing of all labor, Materials, Equipment, services, supplies, Construction, construction-related services and/or other incidentals necessary to successfully perform and complete the Contract and carry out of all the duties and obligations imposed by the Contract.

Working Day - A Calendar Day upon which, in the judgment of the Engineer, weather and soil conditions are such that the Contractor can advantageously Work more than half of his current normal force for more than five (5) consecutive hours on a Controlling Operation. Working Days will not be charged on Saturdays, Sundays, and Holidays unless the Contractor actually Works more than five (5) hours on a Controlling Operation.

Working Drawings - Stress sheets, shop drawings, fabrication details, erection Plans, Plans for false work, forms, centering, cribs, cofferdams and masonry layouts, bending and placing drawings, bar schedules for reinforcement steel, and any other supplementary Plans or similar data that the Contractor may be required to furnish.

Written Notice - Shall be deemed to have been duly served if delivered with signed receipt or if sent by certified registered mail with signed receipt to the last business address known to party who gives the notice.

GP - SECTION 2 BIDDING REQUIREMENTS AND CONDITIONS

GP-2.00 GENERAL

All terms that are capitalized in this GP - Section 2 shall be in accordance with the Department Rules for Prequalification of Contractors, adopted November 28, 2006. Only the Bid of a

Contractor who holds a valid Certificate ten (10) Days prior to the date of Bid Opening will be considered. A Prequalified Contractor is one whose rating and classification have been determined by the Prequalification Committee and ratified by the Director of the Department.

All applicants for prequalification must comply with all Procedures for Prequalification as described in Article II of the Rules for Prequalification of Contractors.

All information must be filed with the Department in sufficient time for action to be completed ten (10) Days before the date of Bid opening.

A prospective Bidder, when prequalifying, shall state in the Application the extent and type of work it considers it is qualified to handle at one time and shall show the exact type of work it has performed during the preceding five (5) years. The information and all other information required by Procedures for Prequalification, as described in Article II of the Rules for Prequalification of Contractors, shall be the basis for a determination of the Bidder's financial rating and work classifications. Following the evaluation, the Contractor may receive a Certificate of Prequalification from the Director of the Department of Public Works.

A Prequalification Certificate, subject to the following provision, is valid through the expiration date stated on the Certificate. The County reserves the right to re-evaluate a Prequalified Contractor. A Bidder who holds a Prequalification Certificate shall furnish additional information bearing on its qualification as may be required. The County reserves the right to reject unopened the Bid of any Bidder who fails to furnish promptly and properly all the information called for when so notified.

A Contractor, dissatisfied with its rating or classification or both, may request a reconsideration on the basis of additional or revised information submitted to the committee in writing and may request a meeting with the Prequalification Committee to support its resubmittal in accordance with the Rules for Prequalification.

EACH BIDDER AND/OR APPLICABLE SUBCONTRACTOR SHALL FURTHER QUALIFY AS OTHERWISE REQUIRED IN THE CONTRACT DOCUMENTS.

A prospective Bidder may purchase Plans if his Prequalification Certificate is valid. Materials suppliers and other interested parties may purchase Plans without prequalification, such Plans to be marked: "NOT FOR BIDDING PURPOSES".

GP-2.01 BID IRREVOCABLE

Unless otherwise provided in the Bid Package, Bid prices are irrevocable for ninety (90) Days following Bid opening.

GP-2.02 CONTENTS OF BID FORMS

All papers included in, bound thereto or attached to the Invitation for Bid and/or the Proposal Form are necessary parts thereof and shall not be detached, separated or altered. The Plans, Standard Specifications, and all other Contract Documents are part of the Invitation for Bid and/or the Proposal Form whether attached thereto or not.

GP-2.03 INTERPRETATION OF QUANTITIES IN BID SCHEDULE

Where designated as estimated quantities, the quantities in the prepared Invitation for Bid are approximate only. Payment to the Contractor will be made only for the actual quantities of Work performed or Materials furnished in accordance with the Contract and as provided in GP-4.04, Variations in Estimated Quantities.

GP-2.04 SITE INVESTIGATION

The Contractor acknowledges that it has investigated and satisfied itself as to the conditions affecting the Work, including but not restricted to those bearing upon transportation, disposal, handling and storage of Materials, availability of labor, water, electric power, Roads and uncertainties of weather, river stages, tides or similar physical conditions at the site, and the Contractor has further confirmed conditions of the ground, and the character of Equipment and facilities needed preliminary to and during prosecution of the Work. The Contractor further acknowledges that it has satisfied itself as to the character, quality and quantity of surface and subsurface Materials or obstacles to be encountered insofar as this information is reasonably ascertainable from an inspection of the site, including all exploratory Work done by the County, as well as from information presented by the drawings and Standard Specifications made a part of this Contract. Any failure by the Contractor to acquaint itself with the available information will not relieve Contractor from responsibility for estimating properly the difficulty or cost of successfully performing the Work. The County assumes no responsibility or liability of any kind, nature or amount for any conclusions or interpretations made by the Contractor on the basis of the information made available by the County.

Notwithstanding anything to the contrary in the Standard Specifications or the Contract Documents, including, but not limited to, GP-4.05, any and all subsurface soil/test borings, sample borings, boring logs, test pits, and/or related documents, reports or materials (collectively, the "Boring Materials") provided by the County, or its engineer, architect, or consultant, to any Bidders or the Contractor are for the convenience of the Bidders and/or the Contractor. THE COUNTY NEITHER EXPRESSLY NOR IMPLIEDLY WARRANTS OR GUARANTEES THAT THE ACTUAL SITE CONDITIONS ENCOUNTERED UNDER THIS CONTRACT WILL BE THE SAME OR SIMILAR TO THOSE SITE CONDITIONS INDICATED BY ANY BORING MATERIALS.

THE CONTRACTOR HAS THE EXPRESS DUTY AND RESPONSIBILITY TO EXAMINE AND SATISFY ITSELF AS TO THE PHYSICAL CONDITIONS OF THE CONTRACT SITE, including, but not limited to, conformation and condition of the ground, character, quantity, and quality of subsurface materials which may be encountered, surface and subsurface conditions

including the presence of rock or groundwater, and all other physical conditions of the Contract site which may affect the Contractor's performance and/or costs and expenses under the Contract. THE CONTRACTOR SHALL NOT RELY ON THE COUNTY AND/OR ANY BORING MATERIALS TO FULFILL THIS EXPRESS DUTY AND RESPONSIBILITY UNDER THE CONTRACT.

NO ADDITIONAL COMPENSATION OF ANY KIND, INCLUDING, BUT NOT LIMITED TO, ADJUSTMENT OF COST OR SCHEDULING, WILL BE CONSIDERED BY THE COUNTY FOR THE CONTRACTOR'S FAILURE TO PROPERLY EXAMINE AND SATISFY ITSELF AS TO THE PHYSICAL CONDITIONS OF THE CONTRACT SITE. NOR WILL SUCH FAILURE BY THE CONTRACTOR RELIEVE THE CONTRACTOR OF ITS OBLIGATIONS, RESPONSIBILITIES, AND LIABILITIES TO ACHIEVE FULL AND FINAL COMPLETION OF THE CONTRACT TO THE COUNTY'S SATISFACTION.

GP-2.05 TAXES - RESPONSIBILITY FOR PAYMENT, EXEMPTIONS, FORMS TO FILE, ETC.

(a) The Contractor is responsible for, and by submitting a Bid agrees to pay, all retail sales, income, real estate, sales and use, transportation and special taxes applicable to and assessable against any Materials, Equipment, processes and operations incident to or involved in the Construction and/or Work. The Contractor is responsible for ascertaining and acquainting itself with such taxes and making all necessary arrangements to pay same.

(b) The County's Director, Office of Budget and Finance, may not authorize payment to a Contractor who has submitted an invoice if that Contractor is indebted by virtue of unpaid taxes or other obligations when in an amount of fifty dollars (\$50) or more to the State of Maryland or any County department or agency or affiliated entity. In this regard, Contractors shall indicate their federal tax identification or social security number as required by the Rules for Prequalification of Contractors.

(c) If taxes or other obligations are owed to the State of Maryland or any County department or agency or affiliated entity, payment shall be deferred, and the Contractor shall be promptly notified. Subsequent release of the deferred payment shall be made promptly when the taxes or other obligations are satisfactorily resolved with no late fee and/or interest of any kind thereon.

(d) The County hereby reserves the right to withhold final payments under this Contract until the Contractor and/or any Subcontractors and/or Third Tier Contracting parties performing any duties under this Contract have paid all taxes or other obligations due the State or the County or any County affiliated entity.

GP-2.06 PREPARATION OF BID

(a) The Bidder shall submit the Bid upon the blank forms furnished by the Administration. The Bidder shall specify a price in U.S. dollars and cents for each Bid Item given, and shall show

the products of the respective unit prices and quantities written in figures in the column provided for that purpose, together with the total amount of the Bid obtained by adding the amounts of the several items.

(b) The Bid Form(s), including the fully and properly executed MBE/WBE forms, shall be filled out legibly in ink or typed. The Bid shall be signed by the Contractor's duly and legally authorized representative or officer, if and as applicable, of the Bidder, and attested by the Contractor's appropriate officer, if and as applicable. There must be on file with the County a copy of the current organizational documents and/or resolution, duly certified by the corporate secretary, if applicable, showing the authority, of the Person so signing on behalf of the Contractor. In lieu thereof, the Contractor may file such evidence with the Administration, duly certified by the corporate secretary, if applicable, together with a list of the names of the Contractor's officers having legal and authority to execute Contract Documents on behalf of and legally bind the Contractor, duly certified, if applicable, which listing shall remain in full force and effect, and shall be materially relied upon by the Administration, until the Director of the Department receives Written Notice to the contrary. In any case, where a Bid is signed by an attorney in fact, the same must be accompanied by a copy of the appointing document, duly certified as described above. All Bids shall be signed in ink. All erasures and/or alterations shall be initialed by the signer in ink.

(c) If the Bid Package requires the Bidder to furnish samples or descriptive literature, it shall be submitted with the Bid, unless the Bid Package provides otherwise.

(d) Bidders must specifically identify any portions of their Proposals deemed to contain confidential, proprietary information or trade secrets. Such designations will not necessarily be conclusive and Bidders may be required to justify why such material should not, upon request, be disclosed by the County under the Maryland Public Information Act, Title 4, of the General Provisional Article of the Annotated Code of Maryland, as amended.

(e) Bid Items for which quantities are identified in the "Summary of Quantity" sheet of the Plans, in the column headed "Contingent" or listed in the "Bid Form" are established for the purpose of obtaining Bids on one or more Bid Items that may be incorporated into the Work.

The Engineer shall have sole discretion in determining whether and to what extent such Bid Items will be incorporated into the Work. The Engineer may order incorporation of such Bid Items at any location within the Contract and at anytime during the Work. These Bid Items may not be located on the Plans. The estimated quantities set out in the Bid Package for such Bid Items are presented solely for the purpose of obtaining a representative Bid price. The actual quantities employed may be only a fraction of, or many times the estimated quantity. Neither party shall make claims for additional compensation because of any increase, decrease or elimination of such Bid Items.

The Contractor is required to pay tax, as applicable, on Materials and supplies that will be incorporated into the Work. The Contractor must pay tax, as applicable, on all Equipment that is purchased and pertains to the Work

Revised,
October 1, 2015

GP-2.07 PROPOSAL GUARANTY/BID SECURITY

No Proposal will be considered unless accompanied by a guaranty of the amount specified in the Proposal in the form of either a certified check, bank cashier's check or a Bid Bond on the form provided therein or an exact facsimile thereof. The Bid Bond must be executed by a Surety that is, as of the date of the Bid: (a) licensed in the State of Maryland, (b) rated "B" or better by the A.M. Best Company, (c) on federal funded projects, authorized by the underwriting limitation contained in the U.S. Department of the Treasury Circular 570, as amended, to guaranty the amount of the Bid, and (d) in good standing as determined by the County's Engineer. The Bid Bond must guaranty payment to the County of liquidated damages as follows: (a) if only one Bid is received, the guaranteed payment shall be five (5%) percent of the Bidder's Bid amount, (b) if two or more Bids are received, the guaranteed payment shall be the difference between the Bidder's Bid amount and the next lowest Bid amount, subject to the limitation that the guaranteed payment not be greater than five (5%) percent of the Bidder's Bid amount. This Bid Bond is required in case the successful Bidder, after issuance of notice of Award, fails to comply, timely and completely, with each of the requirements set forth under Section GP-3.04.

GP-2.08 DELIVERY OF BIDS

Each Bid must be submitted in a sealed envelope plainly marked to indicate its contents. When sent by mail, the sealed Bid must be addressed to the Administration at the address and in care of the official in whose office the Bids are to be received. All Bids shall be filed prior to the time and at the place specified in the Bid Package. Bids received after the time for opening of Bids will be treated in accordance with the provisions of GP-2.12.

GP-2.09 COMMUNICATIONS AND INTERPRETATIONS - PRIOR TO BID OPENING

Any information regarding the requirements or the interpretation of any provision of the General Provisions, Special Provisions, Standard Specifications, Interim Supplemental Specifications or any part of the Bid Package, Bid and/or Bid Form shall be requested, in writing, from the Engineer, and delivered no later than five (5) Days prior to the scheduled date of Bid opening. Responses to questions or inquiries having any material effect on the Bids shall be made by written addenda, or by written notice sent to all purchasers of Contract Documents. **THE CONTRACTOR SHALL NOT MAKE VERBAL INQUIRIES TO THE COUNTY, AS VERBAL INQUIRIES MAY NOT BE ACKNOWLEDGED AND SHALL NOT BE BINDING UPON THE COUNTY IN ANY MANNER OR EXTENT.**

Any and all verbal interpretations and/or oral pre-Bid statements made by the Engineer, County employees or their respective representatives and/or agents shall not be binding in any manner or extent upon the County.

Revised
February 4, 2015

Pre-Bid conferences may be conducted by the Department of Public Works or the applicable County agency or department. If they are to be conducted, notice of the same will be contained in the Bid Package. Any minutes of Pre-Bid conferences are provided as a courtesy to the Bidders and ANY MINUTES PROVIDED ARE NOT BINDING UPON THE COUNTY IN ANY MANNER OR EXTENT.

GP-2.10 AMENDMENTS TO INVITATIONS FOR BIDS

(a) **Form.** Pre-Bid amendments shall be identified as addenda and shall require that the Bidder acknowledge receipt of all addenda issued. The addenda shall reference the portion of the proposed Invitation for Bid and/or Proposal Form it amends. Any addenda shall be issued in writing by the County.

(b) **Distribution.** Addenda shall be sent to all purchasers of Contract Documents.

(c) **Timeliness.** Addenda shall be distributed to allow Bidders a reasonable time to consider them in preparing their Bids. The Bid receipt date shall be changed in the addenda only if the distribution of the addenda, in the sole determination of the Administration, does not permit timely preparation and distribution thereof. If the Administration deems that there is adequate time for consideration of the addenda, the addenda may be silent as to the Bid receipt date.

GP-2.11 PRE-OPENING MODIFICATION OR WITHDRAWAL OF BIDS

(a) **Procedure.** Bids may be modified or withdrawn by Written Notice executed by a duly and legally authorized representative of the Bidder, received in the office designated in the Bid Package before the time and date set for Bid opening.

(b) **Disposition of Bid Security.** If a Bid is withdrawn in accordance with this GP-2.11, the Bid Bond, if any, shall be returned to the Bidder.

GP-2.12 LATE BIDS, LATE WITHDRAWALS, AND LATE MODIFICATION

(a) **Policy.** Any Bid is late if not received at the place designated in the Invitation for Bid and/or Proposal Form at or prior to the time and date set for receipt of Bids. Any request for withdrawal or request for modification received at the place designated in the Invitation for Bid and/or Proposal Form after the time and date set for receipt of Bids is late.

(b) **Treatment.** A late Bid, late request for modification, or late request for withdrawal shall not be considered. Late Bids will be returned to the Bidder unopened.

GP-2.13 OPENING AND RECORDING OF BIDS

(a) Bids, and modifications pursuant to GP-2.11, shall be opened publicly, at the time, date, and place designated in the Bid Package. The name of each Bidder, the Bid price, and such other information as is deemed appropriate by the County shall be read aloud or otherwise made available to the public. This information also shall be recorded at the time of Bid opening. The Bids shall be tabulated or a Bid abstract made. If the Bidder designates in writing trade secrets or other proprietary data to be confidential, in accordance with applicable State law, regulations, and/or these Standard Specifications including, but not limited to, GP-2.06, material so designated in writing by the Bidder shall accompany the Bid but Bidder shall make such readily separable from the Bid in order to facilitate public inspection of the nonconfidential portion of the Bid. After Contract Award, prices, makes, and model or catalog numbers of the items offered, deliveries, and terms of payment shall be available for public inspection at a reasonable time regardless of any designation to the contrary at the time of Bid opening.

(b) The Engineer shall examine the Bids to determine the validity of any requests for nondisclosure of trade secrets and other proprietary data identified in writing by the Bidder. Confidential, proprietary information, and trade secrets furnished by a Bidder may be disclosed to State and/or other County department, or agencies if there is a need for the information and may not be disclosed outside of the County except as provided by the Maryland Public Information Act or other applicable laws and/or regulations.

GP-2.14 MISTAKES IN BIDS

(a) **Mistakes Discovered Before Opening.** A Bidder may correct mistakes discovered before the time and date set for Bid opening by withdrawing or correcting the Bid as provided in GP-2.11.

(b) **Mistakes Discovered After Opening But Prior To Award.** If the Director of the Department knows or has reason to conclude that a mistake may have been made, the Bidder may be required to confirm the Bid. Situations in which confirmation may be requested include obvious, apparent errors on the face of the Bid or a Bid unreasonably lower than the other Bids submitted. If the Bidder alleges mistake, the Bid may only be corrected or withdrawn upon the written approval of the County's Director, Office of Budget and Finance, as follows:

(1) If the mistake and intended correction are clearly evident on the face of the Bid document, the Bid shall be corrected to the intended correct Bid and may not be withdrawn. Examples of mistakes that may be clearly evident on the face of the Bid document are typographical errors, errors in extending unit prices, transposition errors, and arithmetical errors.

(2) Subject to the written approval of the County's Director, Office of Budget and Finance, a Bidder may be permitted to withdraw a low Bid if:

(a) A mistake is clearly evident on the face of the Bid document but the intended correct Bid is not similarly clearly evident; or

(b) The Bidder submits proof of evidentiary value that clearly and convincingly demonstrates that a mistake was made.

(c) **Mistakes Discovered After Award.** Mistakes may not be corrected after Award of the Contract unless and only when the County's Director, Office of Budget and Finance, determines that it would be unconscionable not to allow the mistake to be corrected. Changes in price are not permitted, except as allowed in the County's sole discretion. Corrections, if permitted, shall be submitted to and approved by the County's Director, Office of Budget and Finance before being incorporated into the Contract.

GP-2.15 MINOR IRREGULARITIES

Minor irregularities in Bids, as defined below, may be waived if the County's Director, Office of Budget and Finance, determines, in his sole discretion, that it shall be in the County's best interest. The County's Director, Office of Budget and Finance, may either give a Bidder an opportunity to cure any minor irregularity in its Bid, or waive the minor irregularity where it is to the County's advantage to do so.

When at any public opening of Bids, a Bid appears to be irregular, as herein specified, this apparent fact may be announced when read. Said Bid shall be read as other Bids and then referred to the Director of the Department for consideration and appropriate action thereon in accordance with these General Provisions, laws and regulations, as applicable.

A minor irregularity is one that is merely a matter of form and not of substance, or pertains to some immaterial or inconsequential defect or variation of a Bid or Proposal from the exact requirement of the Bid Package and/or Proposal Form, the correction or waiver of which would not be prejudicial to other Bidders. The defect or variation in the Bid or Proposal is immaterial and inconsequential when its significance as to price, quantity, quality, or delivery is trivial or negligible when contrasted with the total cost or scope of the Bid Package and the labor, Materials, Equipment, services and supplies being procured, and when the intent and meaning of the entire Bid or Proposal is clear.

GP-2.16 CANCELLATION OF INVITATIONS FOR BIDS

(a) Before opening of the Bids, an Invitation for Bid may be canceled, in whole or in part, when the County determines this action is fiscally advantageous or otherwise in its best interest.

(b) When an Invitation for Bid is canceled before Bid opening, the Bids shall be returned to the Bidders submitting them and notice of cancellation shall be included and no party or Person including, but not limited to, the County shall have any liability or obligation of any amount, kind, or nature to another or any other in connection therewith.

GP-2.17 REJECTION OF INDIVIDUAL BIDS OR PROPOSALS

(a) Any Bid may be rejected, in whole or in part, when it is in the best interest of the County to do so.

(b) Reasons for rejection of a Bid may include but are not limited to:

(1) It is not a Responsive Bid.

(2) Unreasonable price.

(3) The Bidder submitting the Bid is determined to be nonresponsible. A determination of nonresponsibility may be made for, but is not limited to, any of the following reasons:

(a) Bidder debarred or ineligible and period of debarment or ineligibility not expired.

(b) The unit prices contained in a Bid are unbalanced.

(c) Evidence of collusion among Bidders.

(d) Inadequate quantity and/or quality of experience, plant, equipment, financing, manpower or other resources required to perform the Contract.

(e) Bidder's workload that, in the judgment of the Administration, might hinder or prevent the prompt completion of the subject Work if Awarded.

(f) Default by the Bidder on other contracts.

(g) Failure to pay or satisfactorily settle all reasonable and just bills due for labor and material on prior or current contracts.

(h) The same Person has an interest in more than one Bid on a Contract exclusive of being named by another Bidder as a Subcontractor.

(i) Failure to perform satisfactorily on other contracts awarded, and the conditions leading to unsatisfactory performance remain unresolved.

(j) Any other reason affecting the Bidder's ability to perform, or a record of business integrity.

(k) Bidder not otherwise qualified and eligible to receive an Award under applicable laws and regulations.

(4) The Bidder fails to supply information to the Engineer promptly, after notification from the Engineer that such information is required in connection with a determination to be made pursuant to this GP-2.17.

GP-2.18 REJECTION OF ALL BIDS, IN WHOLE OR IN PART

(a) After opening of Bids or Proposals but before Award, all Bids or Proposals may be rejected, in whole or in part, when the Engineer, with the approval of the using-County department or agency head, or his/her designee, determines such rejection is fiscally advantageous or otherwise in the County's best interest.

(b) If and as applicable, notice of rejection of all Bids shall be sent to all Bidders that submitted Bids, and Bids which have been opened shall be retained by the Department's Division of Construction Contracts Administration.

GP-2.19 BID EVALUATION AND AWARD

(a) **General.** The Contract is to be Awarded to a Responsible Bidder who is also a Responsive Bidder and whose Bid meets the requirements and evaluation criteria set forth in the Bid Package, and is either the lowest Bid price or lowest evaluated Bid price, in the County's sole discretion.

(b) **Determination of Lowest Bidder.** Bids shall be evaluated to determine which Bidder offers the lowest cost to the County in accordance with the evaluation criteria set forth in the Bid Package.

Except as otherwise provided under GP-2.14 Mistakes in Bids:

(1) The unit price will govern in the event of a discrepancy between the unit price and the extended price (product of unit price multiplied by the quantity).

(2) The sum of the extended prices will govern in the event of a discrepancy between the total lump sum and the extended prices.

(3) The written words for the lump sum will govern in the event of a discrepancy between the lump sum prices written in words and the lump sum prices written in figures.

(4) If a unit price was omitted, the unit price will be determined by dividing the extended price by the quantity.

The Administration reserves the right to make the Award by Bid Item, or groups of Bid Items, rather than total Bid if it is in the best interest of the County to do so, unless the Bidder expressly stated in its Bid that a particular or progressive Award was not acceptable to the Bidder.

(c) **Award.** Upon determination of the Responsible Bidder who is also a Responsive Bidder, and whose Bid meets the requirements and evaluation criteria of the Bid Package and is the lowest Bidder in accordance with these Standard Specifications and the Bid Package, the Contract may be Awarded to that Bidder. In accordance with these Standard Specifications and the Bid Package, a Contract may be Awarded to a Bidder offering a higher quality item than that designated in the Bid Package if that Bidder is a Responsible Bidder with the lowest Responsive Bid whose Bid meets the requirements and evaluation criteria of the Bid Package.

GP-2.20 TIE BIDS

(a) **Definition.** Tie Bids are Responsive Bids from Responsible Bidders that are identical in price, terms and conditions and which meet all the requirements and evaluation criteria set forth in the Bid Package.

(b) **Award.** If two or more Bidders shall be tied for the lowest Bid, quality and service being equal, the Contract shall be Awarded to the Bidder qualified as a minority, as defined in the State procurement regulations. If both Bidders are qualified minorities, as defined in the State procurement regulations, the Contract shall be Awarded to the minority that is a local Bidder. Please see Baltimore County Code, 2003, as amended, Article 10, Title 2, for more information and the governing statute regarding minority Bidders and local Bidders.

GP-2.21 – Reserved.

GP-2.22 MULTIPLE OR ALTERNATE BIDS

Unless multiple or alternate Bids are requested in the Bid Package, such multiple or alternate Bids may not be accepted. However, if a Bidder clearly indicates a base Bid, it shall be considered for Award as though it were the only Bid submitted by the Bidder.

GP-2.23 BID PROTESTS

(a) **Bidder Protest of Award or Alleged Improprieties.** The Bidder must file a written Bid protest of Award pursuant to this GP-2.23 of the Standard Specifications. The Bid protest of Award must be in writing and filed with the Engineer. Oral objections, whether or not acted on, are not protests.

(1) **Time for Filing.** A Bid protest of Award shall be filed not sooner than the date of Award and not later than three (3) Business Days after the date of Award. A protest based on alleged improprieties in the Bid Package which are apparent before the Bid opening or the closing date for receipt of Bids shall be filed not later than five (5) Business Days before the Bid opening date.

(2) **Content of Written Protest.** The written protest must state: the name and address of the Bidder; the Bid or Contract Number; the reasons for protest; and any supporting exhibits, evidence or documents to support the protest.

(b) **Bidder Protest of Bid Rejection.** The Bidder must file a written Bid protest of Bid rejection with the Engineer not later than three (3) Business Days from the date of the Bid rejection. Oral objections, whether or not acted on, are not protests. The written Bid protest must comply with GP-2.23(a)(2).

(c) **Department Response to Bidder Protest.** The Department's Chief of Division of Construction Contracts Administration, or other designated County official, will review the Bidder's protest, as filed pursuant to GP-2.23(a) or (b), and respond to the Bidder in writing within ten (10) Working Days of receipt of protest.

(d) **Bidder Appeal.** The Bidder may appeal the decision by the Department's Chief of Division of Construction Contracts Administration, or other designated County official, (a) to the County's Director of the Office of Budget and Finance for all MBE/WBE-related protests or (b) to the Director, or other designated County director, for all other protests.

The Bidder must file a written appeal with the relevant director not later than three (3) Business Days from the date of the Department response in GP-2.23(c). Oral objections, whether or not acted on, are not appeals. The appeal must comply with GP-2.23(a)(1) and (2), but may include any additional documentation as deemed necessary and appropriate by the Bidder.

(e) **Director Response to Bidder Appeal.** The relevant County director, as appropriate and applicable, will review the Bidder's appeal under GP-2.23(d) and respond to the Bidder in writing within fifteen (15) Working Days of receipt of appeal.

(f) **Second Bidder Appeal.** The Bidder may appeal the decision by the relevant County director, as appropriate and applicable, to the County Administrative Officer (CAO).

The Bidder must file a written appeal with the CAO not later than three (3) Business Days from the date of the director response in GP-2.23(e). Oral objections, whether or not acted on, are not appeals. The appeal must comply with GP-2.23(a)(1) and(2), but may include any additional documentation as deemed necessary and appropriate by the Bidder.

(g) **CAO Response to Bidder Appeal.** The CAO, or his/her duly authorized designee, will review the Bidder's appeal under GP-2.23(f) and respond to the Bidder in writing within twenty (20) Working Days of receipt of appeal. The CAO's, or his/her duly authorized designee's, written decision is final and binding on all involved parties.

GP - SECTION 3 AWARD AND EXECUTION OF CONTRACT

GP-3.01 AWARD OF CONTRACT (See GP-2.19)

Notice of Award shall be faxed, where available, at the number provided with the Bid and/or mailed, by first class mail, to the successful Bidder at the address submitted with the Bid. In addition, the Department's Division of Construction Contracts Administration shall maintain for public inspection a record of the date of the notice of Award for each Contract, if Awarded and as applicable.

(a) The notice of Award, if it be Awarded, shall be within ninety (90) Calendar Days (or as otherwise specified in the Contract) after the opening of the Bid, and will be to the Responsible Bidder with the lowest Responsive Bid whose Bid complies with all the requirements prescribed in these Standard Specifications and the Invitation for Bid. The successful Bidder will be notified by letter, as stated above, to the address shown on its Bid, that its Bid has been accepted and that it has been Awarded the right to execute the Contract Documents with the County. The notice of Award shall be deemed to have been received three (3) Calendar Days after the date on the notice of Award. The successful Bidder will also be deemed to be on notice of the information contained in the public record log referred to above.

(b) If a Contract is jointly Bid by more than one Person, all Persons will be, upon Award, notified and shall execute the Control thereafter and will be held jointly and severally responsible for the performance and Full and Final Completion of the entire Contract.

(c) The right is reserved to cancel and rescind any notice of Award at any time before the County fully executes the Contract Documents. Upon the County's cancellation and rescission of the notice of Award the County shall not be liable or obligated in any kind, nature or amount to any Person.

GP-3.02 RETURN OF PROPOSAL GUARANTY

If a Bid is withdrawn by Written Notice received in the office designated in the Bid Package before the time and date set for Bid opening, the Proposal Guaranty will be returned if requested. Each Proposal Guaranty submitted, other than the three low Bidders, will be considered released immediately following opening and review of the Bids. The Proposal Guaranty of the 2nd and 3rd low Bidders will be returned upon request only, following execution of the Contract with the lowest Bidder, and the Proposal Guaranty of the lowest Bidder (i.e., the Contractor) can only be released upon execution of the Contract and submittal of the Performance Bond and the Payment Bond by the Contractor, as required by GP-3.03.

GP-3.03 PERFORMANCE BOND AND PAYMENT BOND REQUIREMENTS

(a) Acceptable security in the County-required forms for the Performance Bond and a Payment Bond are included in the Bid Package.

(b) A Performance Bond and a Payment Bond must be provided by Contractor from a Surety acceptable to the County who is (1) licensed in the State of Maryland, (2) rated "B" or better by the A.M. Best Company, (3) on federal funded projects, authorized by the underwriting limitation contained in the U.S. Department of the Treasury Circular 570, as amended, to guaranty the amount of the Bid, and (4) in good standing as determined by the County's Engineer as amended at the time of the underwriting and provision of the Payment Bond and Performance Bond.

A Payment Bond and Performance Bond are required for every and each Contract in excess of twenty-five thousand dollars (\$25,000). Each Payment Bond and each Performance Bond shall be in the amount equal to at least one hundred (100%) percent of the Contract price. The fully executed Payment Bond and fully executed Performance Bond shall be delivered by the Bidder to the Department's Division of Construction Contracts Administration no later than the time the Contract is to be executed by the Contractor. If the Bidder fails to deliver the required Payment Bond and the required Performance Bond in a timely manner, the Bid shall be rejected, the Proposal Guaranty shall be enforced, and Award of the Contract may be made to the Responsible Bidder with the next lowest Responsive Bid in accordance with the Invitation for Bid and these Standard Specifications.

All Bond premiums shall be paid by the Contractor. At the direction of the Department, the Contractor may be required to increase the Payment Bond and Performance Bond with such increase to be paid for by the County in the amount of the documented actual cost to the Contractor.

GP-3.04 EXECUTION OF CONTRACT/SUBMISSION OF REQUIRED DOCUMENTS AND MBE/WBE FORMS

The successful Bidder for the Contract will be provided, upon Award of the Contract, five (5) sets of Bid Proposal Forms and Plans and two (2) sets of cross sections free of charge (this number of copies may be increased to fifteen (15) for certain large building projects, in the sole discretion of the Administrator). Any additional Plan sets required by the Contractor may be purchased at the price noted in Bid Package. Individual Plan sheets or complete sets of Plans may be purchased at the prevailing price set by the County.

(a) Not later than ten (10) Business Days after the date of the notice of Award, the successful Bidder shall have obtained and returned the Contract Documents to the County and two (2) sets of cross sections, including, but not limited to: (1) the fully and properly executed Contract Proposal Form, (2) the fully and properly executed Payment Bond and Performance Bond, if required under GP-3.03, (3) the fully and properly completed evidence of insurance required pursuant to GP-7.14 of these Standard Specifications and the Bid Package, and (4) the Proposal Affidavit. The documents referred to in this GP-3.04 (a) (1), (2), (3), and (4) are to be delivered to the Department's Division of Construction Contracts Administration unless expressly specified otherwise by the Engineer or in the Contract Documents.

(b) The Department's Division of Construction Contracts Administration shall record in the public record log, referred to in GP-3.01, the date it received from the successful Bidder each of the properly completed Contract Documents required in GP-3.04 (a) (1), (2), (3), (4) and (5)

Revised
February 4, 2016

above, and the date it received notification from the County's Office of Fair Practices that the successful Bidder's MBE/WBE forms required by the County have been approved. The successful Bidder is deemed to be on notice of such information so recorded.

(c) In the event the County fails to fully execute the Contract Documents within thirty (30) Business Days after the date all of the required documents in this section have been received by the Department, the successful Bidder will have, as its sole remedy, the option to declare the Contract terminated or to agree to an extension of the time for the County to execute the Contract. Should Bidder declare the Contract terminated, in no event shall County be liable or obligated for any losses, costs, expenses or damages in any amount, nature, or kind incurred by any Person including, but not limited to, the Bidder. If the successful Bidder, however, shall fail within thirty-five (35) Business Days of the aforementioned date to deliver Written Notice to the Department's Division of Construction Contracts Administration that it elects to rescind its Bid and have the Contract terminated, the time period for the County to execute the Contract shall automatically be extended for an additional fifteen (15) Business Days.

(d) All Contract Documents remain the property of the County and must not be used on other work but shall be returned to the County upon request by Engineer.

GP-3.05 FAILURE TO EXECUTE CONTRACT

Failure to deliver to the County the required items listed in GP-3.04 within the time specified therein shall be just cause for the annulment and rescission of the notice of Award and the Contractor's and Surety's forfeiture of the Proposal Guaranty to the County, not as a penalty, but in liquidation of damages sustained. Notice of Award may then be made to the Responsible Bidder with the next lowest Responsive Bid, or, at the County's option, the Work may be re-advertised.

GP - SECTION 4 SCOPE OF WORK

GP-4.01 INTENT OF CONTRACT

(a) The Contractor shall (within specified tolerances) perform all Work in accordance with the Contract Documents including, but not limited to, the lines, grades, typical cross sections, dimensions, and other data shown on the Plans or as modified by Contract Modification including the furnishing of all Materials, implements, machinery, Equipment, tools, supplies, transportation, labor, and all other things necessary to the satisfactory prosecution and completion of the Work in full compliance with the Contract Documents.

(b) The Contract Documents are intended to be complementary, and to describe the Construction and completion of the Work. Anything mentioned in the Contract Documents and not shown on the Contract Drawings, or shown on the Contract Drawing, and not elsewhere

mentioned in the Contract Documents shall be of like effect as if it is shown or mentioned in both.

(c) Omissions from the Contract Documents including, but not limited to, Contract Drawings or the misdescription of details of Work which are manifestly necessary to carry out the intent of the Contract Documents and/or Contract Drawings or which are customarily performed shall not relieve the Contractor from performing such omitted or misdescribed details of Work, but they shall be performed as if fully and correctly set forth and described in the Contract Drawings and Contract Documents. The Engineer shall consider modifications of the Bid and/or postponement of Bid opening as may best serve all interested parties where Written Notice of apparent omissions is received by the Engineer five (5) Business Days before the hour prescribed for Bid opening. This is not to be construed as a limitation on the Engineer. If justified and deemed appropriate by the County, the Engineer may issue a Contract Modification or, if after execution of the Contract, prepare a Supplemental Agreement(s) for Extra Work that was not anticipated and/or shown on the Contract Drawings or described in the Contract Documents.

(d) Work described in words that have a well-known technical or trade meaning shall be held to refer to such recognized standard use.

(e) The Contractor shall keep in the office on the Work site a complete set of all Contract Drawings, Standard Specifications, shop drawings, schedules, etc., in good order and available to the Engineer and representatives of the County.

GP-4.02 CONTRACT DOCUMENTS

The Contract Documents are essential parts of the Contract, and a requirement occurring in one is as binding as though occurring in all. They are intended to be complementary and to describe and provide for a complete Work. In the event of any discrepancy between the drawing and figures written thereon, the figures, unless obviously incorrect, will govern over scaled dimensions. In the event of any discrepancy between the Plans and the Standard Specifications, the Plans will govern. If there is a discrepancy between the Standard Specifications and Interim Supplemental Specification, the Interim Supplemental Specifications will govern. Special Provisions will govern over Standard Specifications, Interim Supplemental Specification and Plans.

Special Provisions govern over all other Contract Documents unless expressly stated to the contrary in the Contract Documents.

GP-4.03 ENTIRE CONTRACT

The Contract represents the entire and integrated agreement between the parties thereto and supersedes all prior negotiations, representations or agreements, either written or oral.

GP-4.04 VARIATIONS IN ESTIMATED QUANTITIES

(a) Where the quantity of a Major Contract Item in this Contract is an estimated quantity and where the actual quantity of such Pay Item varies more than twenty-five (25%) percent above or below the estimated quantity stated in this Contract, an equitable adjustment in the Contract price shall be made upon demand of either party. The equitable adjustment shall be based upon any increase or decrease in costs due solely to the variation above one hundred twenty-five (125%) percent or below seventy-five (75%) percent of the estimated quantity. If the quantity variation is such as to cause an increase in the time necessary for completion, the Engineer shall, upon receipt of a written request for an extension of time within ten (10) Days from the beginning of the delay, or within a further period of time which may be granted by the Engineer before the date of final settlement of the Contract, ascertain the facts and make the adjustment for extending the Completion Date as in Engineer's judgment the findings justify.

(b) Should any Contract Items contained in the Bid Package be found unnecessary for the proper completion of the Work, the Engineer may, upon written order to the Contractor, eliminate such Contract Items from the Contract and no allowance will be made for Contract Items so eliminated in making final payment to the Contractor except for Material costs documented incurred prior to notification of the elimination of the Contract Items and for which there is no other possible or reasonable use.

GP-4.05 DIFFERING SITE CONDITIONS

(a) Pursuant to and incorporated GP-2.04, the Contractor is solely responsible for ascertaining soil conditions impacting any and all portions of the Work and soils testing shall be performed by an independent testing firm at Contractor's sole cost and expense. Unless waived in writing by the Engineer, the independent testing shall be performed by a professional engineer licensed by the State of Maryland. The Contractor shall promptly, and before such conditions are disturbed, notify the Engineer in writing of:

(1) Subsurface or latent physical conditions at the site differing materially from those indicated in this Contract; or

(2) Unknown physical conditions at the site of an unusual nature, differing materially from those ordinarily encountered and generally recognized as inherent in Work of the character provided for in this Contract. The Engineer shall promptly investigate the conditions, and if he finds, in his sole discretion, that such conditions do materially so differ and cause an increase or decrease in the Contractor's cost of, or the time required for, performance of any part of the Work under this Contract, whether or not changed as a result of such conditions, an equitable adjustment shall be made and the Contract modified in writing accordingly.

(b) No claim of the Contractor under this General Provision shall be allowed unless the Contractor has given the notice required in (a) above; provided however, the time prescribed therefor may be extended by the County, in its sole discretion.

(c) No claim by the Contractor for an equitable adjustment under this General Provision shall be allowed if asserted after final payment under this Contract.

GP - 4.06 CHANGES

(a) The Engineer may unilaterally, at any time, and without notice to the Surety, if any, by a Change Order, make any change in the Work within the general scope of the Contract, including but not limited to changes:

- (1) In the Contract Documents (including, but not limited to, Contract Drawings and designs);
- (2) In the method or manner of performance of the Work;
- (3) In the County-furnished facilities, Equipment, Materials, services, or Work site; or
- (4) Directing acceleration in the performance of the Work.

If the Contractor intends to assert an equitable adjustment claim under this GP-4.06(a) for changes made by the Engineer, it shall, within thirty (30) Days after receipt of a written Change Order submit to the Engineer a Written Notice setting forth the general nature and monetary extent of such claim for equitable adjustment and the Contractor's position relative to Contract Time, unless the Contract Time was already extended by the County.

(b) The Contractor may request a Change Order by providing the Engineer with Written Notice stating the date, circumstances, and the source of any written or oral order from the County causing the change in Work. Except for claims based on defective Contract Documents, no claim for any change under this GP-4.06(b) shall be allowed for any costs incurred more than twenty (20) Days before the Contractor gives Written Notice as required. Further, in the case of defective Contract Documents in the Bid Package for which the County is responsible, the equitable adjustment shall include any increased costs reasonably incurred by the Contractor in attempting to comply with such defective Contract Documents in the Bid Package.

If the Contractor intends to assert an equitable adjustment claim under this GP-4.06(b) for changes it requested, it shall, within thirty (30) Days after the furnishing of Written Notice submit to the Engineer a written statement setting forth the general nature and monetary extent of such claim and the Contractor's position relative to Contract Time, unless the Contract Time was already extended by the County. This statement of claim for equitable adjustment may be included in the Written Notice submitted pursuant to this GP-4.06(b).

The Engineer will consider the Written Notice provided, and all facts at hand or that can be readily obtained, without unduly delaying the Work, and:

(1) Where the Engineer finds the change presented by the Contractor would cause a difference in Contract cost or Contract Time, he/she will consider alternatives to minimize impacts in the Contract cost or Contract Time in the mutual interest of both parties and commit his final decision to writing in a Change Order; or

(2) Where the Engineer does not find in favor of the change presented by the Contractor, he shall commit his instructions to writing and direct the Contractor's and the Engineer's staff to proceed as if a force account, as further described in GP-9.02, were ordered to provide a record for later re-evaluation as to merits of the change and any adjustments that may be needed.

Both parties are duty-bound to minimize the accumulation of expenses during the time the Engineer requires to complete the evaluation required in this GP-4.06(b). Delay costs and time, to the extent judged reasonable and unavoidable, are to be considered in the Engineer's Change Order, if any.

(c) No order, statement, or conduct of the Engineer shall be treated as a change under this General Provision or entitle the Contractor to an equitable adjustment unless made in a properly authorized and executed Change Order or Contract Modification.

(d) Each Contract Modification or Change Order that affects Contract price, whether an increase or a decrease, shall be subject to the prior written approval of the Engineer and other appropriate authorities and to prior Certification of the County's Office of Budget and Finance of fund availability and the effect of the Contract Modification or Change Order on the Contract budget or the total Contract cost. If, according to the Certification of the County's Office of Budget and Finance, the Contract Modification or Change Order will cause an increase in Contract cost that will exceed budgeted and available funds, the Contract Modification or Change Order may not be made unless sufficient additional funds are made available or the scope of the Contract is adjusted to permit its completion within the Contract budget.

(e) No claim by the Contractor for an equitable adjustment hereunder shall be allowed if asserted after final payment is made pursuant to GP-9.04 and this Contract.

(f) No claim for Extra Work by the Contractor will be granted which includes cost of delays or Work stoppage due to strikes, lockouts, fire, avoidable casualties or damage or delay in transportation for which the County or its agents are not responsible.

GP-4.07 NEGOTIATED PAYMENT PROVISION

(a) The County, without invalidating the Contract, may order changes in the Work by altering, adding to or deducting from the Work, the Contract amount being adjusted accordingly in a Change Order. Extension of time made, or if necessary thereby, shall be adjusted at and documented in a Change Order.

(b) The Engineer shall have the authority to make minor changes in the Work not involving extra cost and not inconsistent with the purpose of the Contract and/or Work. Otherwise, except in an emergency endangering life or property, no Extra Work or change shall be made unless a written order from the Department signed by the Director has been received by the Contractor. No claim for addition to the Contract sum shall be valid unless so ordered in writing by the Director.

(c) The value of any such Extra Work or change under this GP-4.07 shall be determined in one or more of the following ways as determined by the Department:

(1) By Estimate and Acceptance of a Lump Sum

(a) The Contractor shall furnish a breakdown of the estimated Construction cost. The breakdown shall be of sufficient detail to describe the Extra Work and related costs for labor, Material, overhead and profit.

(b) Overhead and Profit

1. Extra Work by Subcontractor:

Subcontractor will be allowed 10% overhead and 10% profit added to the direct labor and Material costs. The Contractor will be allowed to increase the Subcontractors total lump sum by 10% to cover its administration.

2. Extra Work by Contractor:

The Contractor will be allowed 10% overhead and 10% profit added to the labor and Material costs.

(c) The Contractor will be allowed 1% for Contract Bond added to the labor and Material costs, as applicable.

(d) The allowed overhead will include all supervision; no additional allowance will be made for it.

(2) By Unit Prices Named in the Contract or Subsequently Agreed Upon

Such unit prices are to include all supervision, overhead, taxes, insurance and profit.

(3) By Cost and a Fixed Fee

Added to the cost is a fixed fee portion that is to include supervision, overhead, insurance and profit.

(4) By Force Account (Labor and Material Cost plus)

See GP-9.02 entitled "Force Account Work".

Should none of the methods stated in Paragraph 4.07(c) 1, 2, or 3 be applicable, the Contractor shall, providing the Contractor receives an order as defined in Paragraph 4.07(b) of this General Provision, proceed with the Work in accordance with GP-9.02 entitled "Force Account Work". The Contractor and Engineer shall keep accurate costs, in such form as the Engineer may direct, for presentation, together with vouchers, to the Department for determination of the value of the Extra Work included in each Change Order. Pending determination of the final value and the execution of the Change Order, the Engineer may include payments for Materials and labor, as stated in General Provision - Section 9, "Payment", in monthly vouchers.

GP-4.08 UNAUTHORIZED WORK

Work done contrary to or regardless of the instructions of the Engineer, Work done beyond the lines and grades shown on the Contract Drawings, or as given, or any Extra Work done without written authority of the Engineer is unauthorized and at the sole cost and expense of the Contractor and will not be measured or paid for. Work so done may be ordered removed and/or replaced at the Contractor's sole cost and expense.

GP-4.09 FINAL CLEAN UP

Upon Final Acceptance for Maintenance of the Work specified in the Contract and before final payment will be made, the Construction area and all other adjoining areas occupied by the Contractor during the Construction of said Contract, other than those owned by the Contractor, shall be cleaned of all surplus and discarded Materials, spilled Materials, excess Materials left deposited on the permanent Work as a result of the Contractor's operations, falsework, and rubbish and temporary Structures and buildings, that were placed thereon by the Contractor. The adjoining areas mentioned above, outside the normal pay limits for seeding, will be reshaped, seeded and mulched, or otherwise restored as directed by the Engineer at the Contractor's expense.

GP-4.10 WARRANTY OF CONSTRUCTION

(a) In addition to any other warranties at law and specified in the Special Provisions of the Contract, the Contractor warrants for two (2) years after the date of Final Acceptance for Maintenance by the County, that Work performed under this Contract shall conform to the Contract requirements and is free of any defect of Equipment, Material or design furnished, or workmanship performed by the Contractor or any of the Contractor's Subcontractors or suppliers at any tier. Under this warranty, the Contractor at its own and sole cost and expense shall make any Repairs or replacements which, in the judgment of the Engineer, may become necessary during this warranty period on account of any failures or defects. In addition, the Contractor

shall remedy at its own and sole cost and expense any damage to County-owned or controlled real or personal property, when that damage is the result of the Contractor's failure to conform to Contract requirements or any such defect of Equipment, Material, workmanship, or design. The Contractor shall also promptly restore any Work damaged in fulfilling the terms of this General Provision. The Contractor's warranty with respect to Work Repaired or replaced hereunder will run for two (2) years from the date of the County's acceptance of such Repair or replacement; provided that the terms and conditions of all warranties in place following the Final Acceptance for Maintenance shall continue to remain in full force and effect.

(b) The County shall notify the Contractor in writing within a reasonable time after the discovery of any failure, defect, or damage.

(c) Should the Contractor fail to remedy any failure, defect, or damage described in (a) above within a reasonable time after receipt of notice thereof, or in the case of an emergency, the County shall have the right to replace, Repair, or otherwise remedy such failure, defect, or damage at the Contractor's sole cost and expense. To insure the County against the nonpayment of any such costs, on the date of Final Acceptance for Maintenance, the County will either require the retainage of five percent (5%) of the total value of the Contract or require the Contractor to submit a value equivalent maintenance bond. Said maintenance bond shall be in a form and with a Surety approved by the County, binding the Contractor as principal, and the Surety, to promptly and properly replace any improper Work or Materials that may become apparent within the two (2) year warranty period following the date of Final Acceptance for Maintenance. In lieu of a bond, other forms of security such as irrevocable letters of credit, or a bank cashier's or treasurer's check may be accepted. Upon acceptance and approval by the County of such a bond or other security, the sum retained by the County will be released pursuant to GP-Section 9.

(d) In addition to the other rights and remedies provided by this General Provision, all Subcontractors', manufacturers', and suppliers' warranties expressed or implied, respecting any Work and/or Materials shall, at the direction of the County, be enforced by the Contractor for the benefit of the County. In such case if the Contractor's warranty under (a) above has expired, any suit directed by the County to enforce a Subcontractor's, manufacturer's or supplier's warranty shall be at the expense of the County. The Contractor shall obtain any warranties that the Subcontractors, manufacturers, or suppliers would give in normal commercial practice.

(e) If directed by the Engineer, the Contractor shall require any such warranties under this GP-4.10 to be executed in writing to the County.

(f) Notwithstanding any other provision of this General Provision, unless such a defect is caused by the negligence of the Contractor or its Subcontractors or suppliers at any tier, the Contractor shall not be liable for the Repair or any defects of material or design furnished by the County nor for the Repair of any damage which results from any such defect in County furnished Material or design.

(g) The warranty specified herein shall not limit the County's rights under GP-5.13 "Acceptance for Maintenance", or any other rights available to County under the Contract, at law, and/or in equity.

GP - SECTION 5 CONTROL OF THE WORK

GP-5.01 AUTHORITY OF THE ENGINEER

(a) The Engineer shall decide: all questions which may arise as to the quality and acceptability of Materials furnished and Work performed and as to the rate of progress of said Work; all questions which may arise as to the interpretation of any or all Plans and Contract Documents; and all questions as to the acceptable fulfillment of the Contract on the part of the Contractor.

(b) The Engineer shall determine the amount and quantity of Work performed and Materials which are to be paid for under the Contract.

(c) The Engineer shall have the authority to suspend the Work wholly or in part due to the failure of the Contractor to carry out any provisions of the Contract.

GP-5.02 CONFORMITY WITH CONTRACT REQUIREMENTS

All Work performed and all Materials furnished shall be in conformity with the Contract requirements.

In the event the Engineer finds the Materials or the finished product in which the Materials are used or the Work performed are not in reasonably close conformity with the Contract requirements and have resulted in an inferior or unsatisfactory product, the Work or Materials shall be removed and replaced or otherwise corrected by and at the expense of the Contractor.

In the event the Engineer finds the Materials or the finished product in which the Materials are used are not in conformity with the Contract requirements but that acceptable Work has been produced, he shall then make a determination if the Work shall be accepted in the Engineer's sole discretion. In this event, the Engineer will document the basis of acceptance by a Change Order that will, if applicable, provide for an appropriate adjustment in the Contract price. Any action taken pursuant to this General Provision shall not result in an increase of the Contract price.

GP-5.03 DISCREPANCIES IN THE CONTRACT DOCUMENTS

In the event the Contractor discovers any discrepancies in the Contract Documents, the Contractor shall immediately notify the Engineer in writing. The Engineer will then make such corrections and interpretations as may be deemed necessary for fulfilling the intent of the Contract.

GP-5.04 COOPERATION BY CONTRACTOR

The Contractor will keep available on the Work site at all times one complete set of Contract Documents.

The Contractor shall give the Work the constant attention necessary to facilitate the timely progress thereof, and shall cooperate with the Engineer and the Engineer's Inspector at all times and in every way possible.

The Contractor shall assign to the Contract as his agent, a competent Superintendent capable of communicating in English and capable of reading and thoroughly understanding the Contract Documents and thoroughly experienced in the type of Work being performed, who shall receive instructions from the Engineer or his authorized representatives. The Superintendent shall have full authority to execute the order or directions of the Engineer without delay, and to promptly supply such Materials, Equipment, tools, labor and incidentals as may be required. Such superintendence shall be furnished irrespective of the amount of Work sublet. Said Superintendent shall be on the Work site at all times when the Work is in progress.

The Contractor shall so schedule the Work as to ensure efficient and uninterrupted progress and to hold to an absolute minimum the cutting and patching of new Work. All cutting, patching and digging necessary to the execution of the Work is included in the Contract.

The Contractor shall so schedule (to include Subcontracts) the Construction performed by each group or trade that each installation or portion of the Construction shall member with and join with all other Work as required for a complete installation, all according to accepted good Construction practice.

The Contractor shall be responsible for the coordination of the Work of all Subcontractors.

GP-5.05 COOPERATION WITH UTILITIES

It is understood and agreed that the Contractor has considered in its Bid all of the permanent and temporary utility appurtenances in their present or relocated positions and that no additional compensation will be allowed for delays, inconvenience, or damage sustained by the Contractor due to any interference from the said utility appurtenances or the operation of moving them.

The Contractor shall have responsibility for notifying all affected Utility Companies before performing any Work on their utilities and shall cooperate with them. All damage to utility

facilities caused by the Contractor's operations shall be the sole financial and legal obligations, liability and responsibility of the Contractor.

MISS UTILITY: Sections 12-101, *et seq.*, of the Public Utility Companies Article of the Maryland Annotated Code, as amended from time to time, establish requirements regarding protection of existing underground utilities from excavation and demolition activities.

The Contractor shall notify Utility Companies and their public agencies at least forty-eight (48) hours but not more than ten (10) Days before digging. Locate requests may be processed through Ticket Check by calling this special toll-free number: 1-866-821-4226, where the caller will be prompted through the steps to retrieve ticket status, using a 10 digit Contractor's number. Contact the MISS UTILITY help desk at 410-712-0056, x4040 or check the www.missutility.net/maryland web site for more information on how to use the Ticket Check system.

One call to 1-800-257-7777 or use of Ticket Check will reach most companies and organizations that have underground facilities in the County. A list of member utilities belonging to MISS UTILITY is on the MISS UTILITY website at www.missutility.net/maryland. Other utilities, which are non-participants in MISS UTILITY, may also be encountered. It is the Contractor's responsibility to identify all utilities, to inform the proper authorities of Work near the utility line, and to exercise caution at all times in regard to them.

The UTILITY SERVICE PROTECTION CENTER (MISS UTILITY; (800 257-7777) may also be called between 7:00 a.m. and 5:00 p.m., Monday through Friday, excluding Holidays. Emergencies will be processed promptly on a 24-hour basis.

FIRE HYDRANTS: The Contractor shall notify the County Fire Department's Fire Dispatch Liaison Officer (410 887-4592) prior to starting any Work involving the removal or relocation of existing fire hydrants.

SANITARY SEWERS: To protect against accidental clogging, existing sanitary sewer channels shall be covered within manholes, as directed by the Engineer, prior to any grubbing or grading operations. This will not be a separate Pay Item, but shall be included in the cost of other Pay Items.

ADDITIONAL COSTS: The cost of charges for marking the locations for water and sewer utilities by the organizations which are part of the MISS UTILITY program shall be included as an incidental cost in the Contractor's Bid.

Water mains, gas mains, storm drains, sanitary sewers, and other utilities are shown on the Plans, in accordance with the best information available to the County, for the convenience of the Contractor. THE COUNTY ASSUMES NO RESPONSIBILITY FOR ACCURACY OR COMPLETENESS OF THE INFORMATION SHOWN ON THE PLANS AND THE CONTRACTOR SHALL BE FULLY AND SOLELY RESPONSIBLE FOR VERIFYING THE LOCATION OF ALL UTILITIES. Existing mains and services shall be carefully protected and any damage to them caused by the Work and/or the Contractor shall be immediately Repaired to

the satisfaction of the Engineer by the Contractor at its own expense, using Materials of the quality and kinds damaged.

GP-5.06 COOPERATION BETWEEN CONTRACTORS

(a) Each and every contractor under contract with the County, with regard to any adjoining or overlapping Work or work of or with another under contract with the County, shall cooperate with each other as necessary. Such cooperation shall include:

- (1) Arrangement and conduct of Work and/or work; and
- (2) Storage and disposal of Materials, etc., by each in such manner as to not unnecessarily interfere with or hinder the progress of the Work and/or work being performed by other contractors. Contiguous Work shall be joined in an acceptable manner.

(b) The Administration and Department shall have the right, at any time, to contract for and perform other Work and/or work on, near, over or under the Work covered by this Contract. In addition, other Work and/or work may be performed under the jurisdiction of another public body, public entity, the County agency or entity, County affiliate or any public educational or college entity. In such cases, when a dispute arises among one or more contractors, the Engineer will decide which department, body, or entity has jurisdiction over said dispute. The Contractor shall cooperate fully with such other contractors and carefully fit Contractor's own Work to such other work as may be directed by the Engineer.

(c) The Contractor agrees that in the event of dispute as to cooperation the Engineer will act as referee. The Contractor waives its rights and remedies to make a claim or take any other action of any kind against the Administration for any inconvenience, delay or loss experienced by Contractor because of the presence and operations of other contractors.

(d) The County reserves the right to let other contracts in connection with paving and utilities adjoining this Work. The Contractor shall afford other contractors reasonable opportunity for the introduction and storage of their materials and the execution of their work, and shall properly connect and coordinate its Work with theirs.

If any part of the Contractor's Work depends for proper execution or results upon the work of any other contractor, the Contractor shall inspect and promptly report to the Engineer any defects in such work that render it unsuitable for such proper execution and results. Failure to inspect and report shall constitute an acceptance of the other contractor's work as fit and proper for the reception of the Work. The Contractor shall take all reasonable precautions during construction to prevent damages to previously installed work. The Contractor shall monitor the previously installed area/work while performing its assigned Work, and shall advise the Engineer immediately if defects in that previously installed work become apparent.

To ensure the proper execution of Contractor's subsequent Work, the Contractor shall verify Work already in place and shall at once report to the Engineer any discrepancy between the executed Work and the Contract Drawings.

GP-5.07 AUTHORITY AND DUTIES OF INSPECTORS

The Inspector shall be authorized to inspect all Work done and all Material furnished. Such inspection may extend to all or any part of the Work and to the preparation, fabrication or manufacture of the Materials to be used. The Inspector is not authorized to revoke, alter or waive any requirements of the Contract, nor is he authorized to approve or accept any portion of the Work. The Inspector is authorized to call the attention of the Contractor to any failure of the Work or Materials to conform to the Contract. The Inspector shall have the authority to reject Materials or suspend the Work until any questions at issue can be referred to and decided by the Engineer. The Inspector shall perform his duties at such times and in such manner as will not unnecessarily impede progress on the Contract.

The Inspector shall in no case act as foreman or perform any other duties for the Contractor, nor interfere with the management of the Work by the Contractor. Any advice, instruction, direction or other order which the Inspector may give the Contractor shall not be construed as binding the Engineer in any way, or releasing the Contractor from fulfilling all of the terms of the Contract.

Where there is disagreement between the Contractor, the Superintendent, or any other contractor and the Inspector, such as refusal by the Contractor to use properly approved Material, performing Work not in compliance with Plans and Contract Documents, and/or refusing to suspend Work until problems at issue can be referred to and decided by the Engineer, the Inspector will immediately direct the Engineer's attention to the issues of disagreement. If the Contractor still refuses to make corrections and/or comply or suspend Work, as applicable, the Engineer may prepare and deliver in writing to the Contractor, by mail or otherwise, a written order suspending the Work and explaining the reason for such shutdown. As soon as the Inspector is advised of the delivery of the shutdown order, the Inspector shall immediately leave the site of the Work and any Work performed during the Inspector's absence will not be accepted or paid for and may, in the sole discretion of the Engineer be required to be removed and disposed of at the Contractor's sole cost and expense.

GP-5.08 INSPECTION OF WORK

All Materials and each part or detail of the Work shall be subject at all times to inspection by the Engineer and/or the Inspector, and the Contractor will be held strictly to the Materials, workmanship, and the diligent execution of the Contract. Such inspection may include mill, plant or shop inspection, and any Material furnished under the Contract is subject to such inspection. The Engineer and/or Inspector shall be allowed access to all parts of the Work and shall be furnished with such information and assistance by the Contractor as is required to make a complete and detailed inspection of all parts of the Work.

If the Engineer requests it, the Contractor, at any time before Partial Acceptance for Maintenance and/or Final Acceptance for Maintenance of any Work, shall remove or uncover such portions of the finished Work as may be directed. After examination, the Contractor shall restore said portions of the Work to the standards required by the Contract. Should the Work thus exposed or examined prove acceptable, adjustments in Contract Time and price will be made pursuant to Section GP-4.06 for the uncovering or removing, and the replacing of the covering or making good of the parts removed. Should the Work so exposed or examined prove unacceptable, the uncovering, or removing and replacing, shall be at the Contractor's sole cost or expense.

When the United States Government, the State, another local government or municipality, or any railroad, corporation or other Person is to pay a portion of the cost of the Work covered by this Contract, their respective representatives shall have the right to inspect and approve the Work.

If the Contract Documents, the Engineer's instructions, laws, regulations, executive orders, ordinances, or any public authority require any Work to be specially tested or approved, the Contractor shall give the Engineer timely notice of its readiness for inspection, and if the inspection is by another authority, the date fixed for such inspection. Inspections by the Engineer shall be made promptly, and where practicable, at the source of supply. Any Work covered without approval of the Engineer must, if required, be uncovered for examination at the Contractor's sole cost and expense.

If initial tests and/or inspections show substandard products, Materials, workmanship, etc. and the Contractor elects, with the Engineer's approval, to perform additional tests and/or inspections to prove the acceptability of the substandard products, Materials, workmanship etc., the Contractor shall perform same at Contractor's sole cost and expense.

GP-5.09 REMOVAL OF DEFECTIVE WORK

All Work and Materials which do not conform to the requirements of the Contract will be considered unacceptable, unless otherwise determined acceptable under the provisions in GP-5.02.

Any defective Work, whether the result of poor workmanship, use of defective Materials, damage through carelessness or any other cause, found to exist shall be removed and replaced by Work and Materials which shall conform to the Contract Documents or shall be remedied otherwise in an acceptable manner authorized by the Engineer.

Upon failure on the part of the Contractor to comply promptly with any order of the Engineer made pursuant to these General Provisions, the Engineer shall have authority to cause defective Work to be remedied or removed and replaced and unauthorized Work to be removed and to deduct the costs from any monies due or to become due the Contractor under this Contract.

GP-5.10 LOAD RESTRICTIONS

(a) The Contractor shall comply with all applicable State and local laws, regulations and requirements pertaining to speed, size and weight of motor vehicles.

(b) The Administration may indicate in the Contract any load restrictions on any Road or Structure within the vicinity of the Work site.

(c) The Contractor shall take into account any and all posted Bridges, the crossing of which might be contemplated by the Work of the Contract. No loads in excess of posted limits will be allowed in the prosecution of the Work on any Contract, unless the required permits are obtained from the appropriate State and local governmental agencies.

(d) The Contractor shall consider possible detrimental effects of operating heavy paving and grading Equipment contiguous to retaining walls, pipe Culverts, arches, forms for concrete Work as well as any Construction existing prior to this Contract.

(e) The Engineer shall have the right to limit passage of heavy Equipment (plus loads) when such passage or usage is causing apparent or visible damage to embankments, paving, Structures or any other property.

(f) Within Baltimore City limits, and within the limits of the Baltimore City-maintained watershed properties, the Department of Transportation of the City of Baltimore has jurisdiction for oversize and overweight vehicle movements. Permits are obtainable from the Baltimore City Department of Transportation.

GP-5.11 MAINTENANCE OF WORK DURING CONSTRUCTION

(a) The Contractor shall maintain the Work during Construction and until Final Acceptance for Maintenance by the County. This maintenance shall constitute continuous and effective Work prosecuted as required with adequate Equipment and forces to the end that all parts of the Work be kept in satisfactory condition at all times.

The Contractor shall at all times keep the Work site free from accumulations of waste Material or rubbish caused by its employees, Subcontractors, or Work, and at the Final Acceptance for Maintenance of the Work, shall remove all rubbish, waste, Contractor's tools, scaffolding and surplus Material from and about the Work site. In case of dispute, the County may remove the waste and rubbish and charge the cost to the Contractor as the Engineer shall determine to be just, in his sole discretion.

All debris shall be kept sprinkled to reduce dust and shall be promptly removed from any Structure, and no combustible Materials shall be stored against perimeter walls of any Work.

The Contractor shall clean entirely any Structure as it is completed, wash all windows, scrub all floors at least once, and leave all floors free from spots and blemishes. The interior of any Structure and the entire Work site shall be left "broom clean," or its equivalent.

(b) Particular attention shall be given to drainage, both permanent and temporary. The Contractor shall use all reasonable precautionary measures to avoid damage or loss that might result from accumulations and concentrations of drainage water, and material carried by such water and such drainage shall be diverted or removed when necessary to prevent damage to excavation, embankments, surfacing, Structures or any other property. Suitable measures shall be taken by the Contractor to prevent the erosion of soil in all Construction areas where the existing ground cover has been removed and/or disturbed.

The Contractor shall remove all water, including rain water, encountered during the entire progress of the Work, using pumps, drains or other methods approved by the Engineer. Excavations and the Work site shall be kept free from water until all backfilling is completed. The water shall be discharged to catch basins, or other drainage points as directed by the Engineer.

(c) All cost of maintenance Work during Construction and before Final Acceptance for Maintenance by the County shall be included in the Bid and the Contractor will not be paid an additional amount for such Work, except as otherwise provided in the Contract Documents.

(d) In the event that the Contractor's Work is ordered to shut down for failure to comply with any provision of the Contract, the Contractor shall maintain the entire Work site as provided herein, and provide such ingress and egress for local residents or tenants adjacent to the Work site, for tenants of the Work site, and for the general public as may be necessary during the period of suspended Work or until the Contract has been declared in default.

(e) On Contracts where traffic flow is maintained, the Contractor shall be responsible for Repair of all traffic damages to the Work, either partially or totally completed, until Final Acceptance for Maintenance of the Work is achieved. Responsible, as used here, shall mean the responsibility for restoration and the cost thereof unless otherwise expressly provided for in the Special Provisions.

GP-5.12 FAILURE TO MAINTAIN ENTIRE PROJECT

Failure on the part of the Contractor, at any time, to respond to the provisions of GP-5.11 will result in the Engineer's immediately notifying the Contractor to comply with the required maintenance provisions. In the event the Contractor fails to proceed with corrections to unsatisfactory maintenance so as to conform to the provisions of GP-5.11 within four (4) hours after receipt of such notice, the Engineer may notify the Contractor to suspend all other Work on the Contract until the unsatisfactory maintenance is corrected. In the event that the Contractor has failed to commence with adequate corrective measures within four (4) hours after receipt of such notice the Engineer may immediately proceed with adequate forces and Equipment to maintain the Contract Work and the entire cost of this maintenance will be deducted from any monies due or to become due to the Contractor from the County. The Contractor is and remains responsible for any injury or damage that may result from lack of maintenance of any refilled excavation at any time until Final Acceptance for Maintenance by the County. The Engineer may suspend Work as further described in GP-8.07.

GP-5.13 ACCEPTANCE FOR MAINTENANCE

(a) **Partial Acceptance for Maintenance.** If at any time during the performance of the Work the Contractor substantially completes a unit or portion of the Work, the Contractor may request the Engineer to make final inspection of that unit or portion. If the Engineer determines upon inspection that the unit has been satisfactorily completed in compliance with the Contract, the Engineer may make a written Partial Acceptance for Maintenance of that unit or portion of Work, and the Contractor may be relieved of further maintenance responsibility for that unit or portion of Work. Generally, Partial Acceptance for Maintenance will only be considered when the Administration feels that such action is in the public interest. Such Partial Acceptance for Maintenance of any unit or portion of Work shall in no way void or alter any of the terms of the Contract.

(b) **Final Acceptance for Maintenance.** Upon due notice from the Contractor of presumptive completion of the Contract Work, the Engineer shall make a Construction inspection and if at such inspection all Construction and Contract Work provided for and contemplated by the Contract is found completed, such inspection shall constitute the final inspection and the Engineer shall make the Final Acceptance for Maintenance of the Work as of that date, and the Contractor shall be notified of such Final Acceptance for Maintenance in writing. After Final Acceptance for Maintenance, the Administration will assume responsibility for maintenance except where otherwise provided by the Contract.

(c) If, however, at any Construction inspection any Contract Work, in whole or in part, is found unsatisfactory, the Engineer shall give the Contractor the necessary instructions as to the Contract Work required for Final Acceptance for Maintenance by the County. The Contractor forthwith shall comply with and execute such instructions. Upon completion of such Contract Work, another inspection shall be made which shall constitute the final inspection if the said Contract Work is completed satisfactorily. In such event, the Engineer shall make the Final Acceptance for Maintenance and the Contractor shall be notified as aforesaid. After Final Acceptance for Maintenance, the Administration will assume responsibility for maintenance except where otherwise provided by the Contract.

(d) Unless otherwise provided in this Contract, Partial Acceptance for Maintenance and/or Final Acceptance for Maintenance by the County shall be made as promptly as practicable after completion and inspection of all Work required by this Contract, or that portion of the Work that the Engineer determines can be accepted separately. Partial Acceptance for Maintenance and/or Final Acceptance for Maintenance shall be final and conclusive except as regards latent defects, fraud, and such gross mistakes as may amount to fraud or the County's rights under any warranty or guarantee or any claims or counter claims reserved by the County.

(e) No claim for Extra Work will be granted which includes cost of delays or Work stoppage due to strikes, lockouts, fire, avoidable casualties or damage or delay in transportation for which the County or officials, employees, or its agents are not responsible.

GP-5.14 CLAIMS

Unless a shorter period is prescribed by law or elsewhere in this Contract:

(a) The Contractor shall file a Written Notice of claim for extension of time, equitable adjustment, extra compensation, damages, or any other matter (whether under or relating to this Contract) with the Engineer within ninety (90) Days after the basis for the claim is known or should have been known, whichever is earlier.

(b) Contemporaneously with or within ninety (90) Days of the filing of a notice of a claim, but no later than the date that final payment for the Pay Item and/or portion of the Work for which the claim is made, a Contractor shall submit the claim to the appropriate Engineer. The claim shall be in writing and shall contain:

- (1) An explanation of the claim, including reference to all Contract provisions upon which it is based;
- (2) The amount of the claim;
- (3) The facts upon which the claim is based;
- (4) All pertinent data and correspondence that the Contractor relies upon to substantiate the claim;
- (5) A Certification by a legally authorized representative of the Contractor or Subcontractor, as applicable, that, to the best of the Person's knowledge and belief, the claim is made in good faith, supporting data are accurate and complete, and the amount requested accurately reflects the Contract adjustment for which the Person believes the Administration is liable; and
- (6) Itemized supporting data for the elements of cost the Contractor claims to have incurred or which the Contractor will incur. This data shall be in sufficient detail to permit analysis by the Administration of Material, labor, Equipment, Subcontract and overhead costs as well as profit and shall include all Work covered by the claim, whether deleted, added, or changed. Subcontractors' costs shall be supported by similar detailed data.

(c) A notice of claim or a claim that is not filed within the prescribed time shall be dismissed.

GP-5.15 DISPUTES

(a) Except as otherwise may be provided by applicable law or regulation, all disputes arising under or as a result of a breach of this Contract that are not disposed of by mutual agreement shall be resolved in accordance with this General Provision.

(b) As used herein, "claim" means a written demand or assertion by one of the parties seeking, as a legal right, the payment of money, adjustment or interpretation of Contract terms, or other relief, arising under or relating to this Contract.

A voucher, invoice, or request for payment that is not in dispute when submitted is not a claim under this General Provision. However, if the submission subsequently is not acted upon in a reasonable time, or is disputed either as to liability or amount, it may be converted to a claim for the purpose of this General Provision.

(c) When a claim cannot be resolved by mutual agreement, the Contractor shall submit a written request for decision to the Department's Chief of the Division of Construction Contracts Administration, or other designated County official, for his decision in consultation with the County Office of Law. The Contractor's written request shall set forth all the facts surrounding the controversy, including, but not limited to, those items listed in GP-5.14(b). Any claim by the County shall be decided in like manner.

(d) The Contractor, at the discretion of the Engineer, may be afforded an opportunity to be heard and to offer evidence in support of his claim. Pending resolution of a claim, the Contractor shall proceed diligently with the performance of the Contract.

(e) The Department's Chief of the Division of Construction Contracts Administration, or other designated County official, shall decide any and all claims. The decision by the Department's Chief of the Division of Construction Contracts Administration, or other designated County official, shall be issued within ninety (90) Days on matters of less than fifty thousand dollars (\$50,000) and within one hundred eighty (180) Days on matters of fifty thousand dollars (\$50,000) or more. The written decision of the Department's Chief of the Division of Construction Contracts Administration, or other designated County official, shall be final and binding unless appealed in writing to the Director of the Department within thirty (30) Days of the Chief's, or other designated County official's, written opinion to the parties. If the Chief's, or other designated County official's, decision is timely appealed in writing to the Director of the Department, the Director of the Department, serving as referee, will review the written appeal submitted to assure all reasonable attempts were made to resolve the appeal.

(f) The Director shall issue his/her decision in writing within ninety (90) Days. The Director's decision shall be final and conclusive unless a written appeal is mailed or otherwise filed with the County Administrative Officer within thirty (30) Days of the Director's written decision.

(g) When the County Administrative Officer is satisfied all efforts at the Department level were made to resolve the dispute, a claim shall be resolved as follows:

(1) Subject to, and without in any way enlarging or limiting the other provisions of the Contract, the parties to any Agreement which adopts or incorporates by reference these Standard Specifications, appoint the County Administrative Officer as an administrative hearing

officer pursuant to Article 25A, "Chartered Counties of Maryland", of the Annotated Code of Maryland.

(2) The parties further grant the County Administrative Officer the right to delegate this responsibility and authority in writing to a County official who is a registered professional engineer, independent of the Department of Public Works's Division of Construction Contracts Administration, or to any other County official.

(3) For disputes involving ten thousand dollars (\$10,000) or more the decision of the administrative hearing officer shall be final and binding on both parties, subject only to such appeals on the record as provided by Article 25A. For disputes involving less than ten thousand dollars (\$10,000), the decision of the administrative hearing officer shall be final and binding on both parties.

GP - SECTION 6 CONTROL OF MATERIAL

GP-6.01 GENERAL

All Materials shall meet all quality requirements of the Contract. In order to expedite the inspection and testing of the Materials, the Contractor shall notify the Engineer in writing of the sources from which the Contractor proposes to obtain all Materials requiring approval, testing, inspection, or Certification prior to incorporation into the Work as soon as possible after receipt of notification of Award of the Contract.

To expedite the approval of this notice a list of Approved Sources of Supply is available through the Department's Division of Construction Contracts Administration. If all Materials are to be supplied from the sources on the Approved Sources of Supply list, no written notification to that effect is required unless specifically requested by the Engineer or required by the Contract. If other sources are to be used, they shall be submitted for approval to the Engineer. It shall be the Contractor's responsibility to insure that all Materials are supplied from approved sources. Once the source of concrete or bituminous concrete for exposed final surfaces has been selected, that source is to provide Material for all Construction of continuous surfaces on all of the Contract Work. Submittal of all sources of supply will still be required for contracts involving State or federal funding. The Engineer will inform the Contractor as to source acceptability as soon as possible.

GP-6.02 STORAGE AND HANDLING OF MATERIALS

Materials shall be stored so as to assure the preservation of their quality and acceptability for the Work. Stored Materials shall, at the discretion of the Engineer, be again inspected prior to their use in any Work even if approved before storage. Stored Materials shall be located so as to facilitate their prompt inspection. Approved portions of the Right-of-Way or Work site may be used for storage purposes and for the placing of the Contractor's plant and Equipment; such

storage areas must be restored to their original condition by the Contractor prior to Final Acceptance for Maintenance of the Work at Contractor's sole cost and expense. Any additional space required must be provided by the Contractor at Contractor's sole cost and expense.

Materials shall be handled in such a manner as to preserve their quality and acceptability for the Work.

GP-6.03 UNACCEPTABLE MATERIALS

(a) Materials represented by samples taken and tested in accordance with the County-specified tests and failing to meet required values shall be considered to be defective regardless of prior tests or approvals.

(b) Unless otherwise allowed by the Engineer as set forth below, defective Materials shall be removed from the Work site and any tags, stamps or other markings implying conformance with Contract Work removed for those Materials and returned to the Engineer or obliterated if located on the Materials.

(c) Where defects can be corrected, the Contractor may propose such corrective action as the Contractor deems appropriate to the Engineer. The Engineer may approve the corrective action but in so doing does not assume responsibility for the success thereof. Retests will be made to determine the acceptability of the Material after corrective measures have been taken by the Contractor.

(d) The cost of replacing, correcting and/or removal of defective Material will be the sole responsibility of the Contractor.

(e) The cost of Repairing or replacing Materials damaged by the installation, correction and/or removal of defective Materials will be the sole responsibility of the Contractor.

GP-6.04 ADMINISTRATION FURNISHED MATERIAL

The Contractor shall furnish all Materials required for Full and Final Completion of the Work, except those specified to be furnished by the Administration. Materials furnished by the Administration will be delivered or made available to the Contractor at the point or points specified in the Special Provisions. The cost of handling and placing all Materials, after they are delivered to the Contractor, shall be considered as included in the Contract price for the Contract Item in connection with which they are used.

The Contractor shall be held responsible for all Material delivered to Contractor, and deductions will be made from any monies due or to become due to the Contractor to make good any shortages and deficiencies, from any cause whatsoever, and for any damage which may occur after such delivery, and for any demurrage charges.

In cases where Materials are supplied by the Administration and incorporated in the Contract Work by the Contractor, Materials inspection and acceptance will not be prerequisite for Final Acceptance for Maintenance as the Work pertains to these Contract Items.

GP-6.05 MATERIALS

Materials include all manufactured products and all processed and unprocessed natural substances required for the Full and Final Completion of the Contract. The Contractor in accepting the Contract is assumed to be thoroughly familiar with the Materials required and their limitations as to use and requirements for connections, setting, maintenance and operation.

Materials testing shall be performed by an independent testing firm, paid for by the Contractor, which has previously been approved by the County and the Architect and/or Design Engineer. Certified copies of all such test reports shall be submitted to the Engineer for approval.

Whenever an article, Material or Equipment is specified and a fastening, furring, connection (including utility connections), bed or accessory is normally considered essential to its installation in good quality Construction, such shall be included as if fully specified. Nothing in the Contract shall be interpreted as authorizing any Work in any manner contrary to applicable law, codes or regulations. (See GP-7.01).

(a) Approval

All Materials are subject to the Engineer's and the Architect's and/or Design Engineer's approval as to conformity with the Contract Documents, quality, design, color, etc. No Work for which approval is necessary shall be contracted for, or used, until written approval is given by the Engineer and the Architect and/or Design Engineer. Approval of a Subcontractor, as such, does not constitute approval of a Material which is other than that included in the Contract Documents.

(b) New Materials

Unless otherwise specified, all Materials shall be new.

(c) Quality

Unless otherwise specified, all Material shall be of the best quality of the respective kinds.

(d) Samples

The Contractor shall furnish for approval all samples of the Materials as directed. The Work shall be the same as the approved samples.

(e) Painting and Color

The Architect and/or Design Engineer and the Contractor shall jointly prepare the paint and color schedules. The Architect and/or Design Engineer shall direct the exact color, texture and finish.

(f) Proof of Quality

The Contractor shall, if required, furnish satisfactory evidence as to the kind and quality of Materials either before or after installation. The Contractor shall pay for any tests as may be deemed necessary in relation to “Substitutions” as specified in GP-6.05(i).

(g) Contractor’s Option

When several products or manufacturers are named in the Contract Documents for the same purpose or use, then the Contractor shall select any of those so named. However, all of the units of a thing required for a Contract must be the same in material and manufacture.

(h) “Or Equal”, “Equal”, “Approved Equal”

The above terms are used as synonyms throughout the Contract Documents. They are implied in reference to all named manufacturers. Only Materials that, in the opinion of the Engineer, are fully equal in all details of Construction, methods of assembly, finish and design quality will be considered. (See (a), (c), (e) and (i) of this General Provision)

(i) Substitutions

Should the Contractor desire to substitute another Material for one or more specified by name, the Contractor shall apply, in writing, for such permission from the Engineer and state the credit or Extra Work involved by the use of such Material. The Engineer will not consider the substitution of any Material different in type or Construction methods unless such substitution effects a benefit to the County. (See (a) and (d) of this General Provision.)

The Contractor shall not submit for approval Materials other than those specified, unless the Contractor concurrently submits a written statement explaining why such a substitution of Materials is proposed. Approval of a “substitute” material by the Architect and/or Design Engineer when the Contractor has not designated such Material as a “substitute,” shall not be binding on the County nor release the Contractor from any obligations of the Contract, unless the Engineer and the Architect and/or Design Engineer approves such “substitutions” in writing.

(j) Storage

The Contractor shall confine apparatus and storage of Materials to the “off-Road” area delineated as the “limit of contract” or “limit of disturbance”, as applicable. The Contractor shall not load or permit any part of any Structure to be loaded with a weight that will endanger the safety of any Structure or any part thereof.

GP-6.06 SALVAGE MATERIALS

For Contract Work that involves the renovation, repair, and/or improvement of an existing Structure, the County has the right to claim as salvage any equipment and/or materials removed under the Work of the Contract. Should such right of salvage be exercised by the County, through verbal notification to the Contractor, the Contractor shall be responsible for the removal, protection, and transport, intact, of all salvaged equipment and/or materials to one or more government locations as directed by the Engineer. The Contractor shall provide the County with five (5) days advance notice prior to delivery of any salvage item to the designated government location. Until such time that items claimed as salvage by the County are provided to the County, the Contractor shall move and neatly store said items in a dry, secure location at the Contract Work site approved by the Engineer. Any and all costs associated with salvage materials, including, but not limited to, removal, protection, transportation and storage, shall be included by the Contractor in its Bid and Bid Package, and there will be no additional payment of any kind by the County for salvage operations or salvage materials.

GP - SECTION 7 LEGAL RELATIONS AND RESPONSIBILITY TO PUBLIC

GP-7.01 COMPLIANCE WITH LAWS

The Contractor hereby represents and warrants that:

- (a) It is qualified to do business in the State of Maryland and that it will take such action as, from time to time hereafter, may be necessary to remain so qualified;
- (b) It is not in arrears with respect to the payment of any monies due and owing the State or the County, or any department or unit thereof, including, but not limited to the payment of taxes and employee benefits, and that it shall not become so in arrears during the term of this Contract;
- (c) It shall comply with all federal, State and local laws, regulations, codes, executive orders, and ordinances applicable to its activities and obligations under this Contract; and
- (d) All requirements set forth in federal assistance instruments applicable to this Contract shall be satisfied. The Contractor understands and agrees that it is possible federal and/or State funds may be used in connection with the Contract. Accordingly, prior to commencing any and all Work under the Contract, the Contractor shall ascertain and verify if federal and/or State funds are to be used by the County. It is the Contractor's obligation to ascertain if the County will use any federal and/or State funds in connection with the Contract or any portion thereof. Further, it is the obligation of the Contractor and the Contractor understands and agrees that should any federal and/or State funds be used by the County in connection with the Contract, the Contractor shall adhere to and comply with all applicable federal and/or State laws, regulations, circulars, executive orders, procedures and guidelines, as and if applicable, as amended from time to time, at no additional cost or expense to the County.

GP-7.02 PERMITS AND LICENSES

Revised
October 11, 2013

(a) The Contractor shall procure at Contractor's sole cost and own expense such permits, licenses, insurances and governmental approval as may be necessary in order to comply with federal, State and local laws, ordinances, codes, executive orders and regulations in performance of the Contract. The Contractor shall further give any notices necessary and incidental to the due and lawful prosecution of the Contract.

(b) The cost incurred in compliance with all permits shall be incidental to and included in the Bid. Any required permits, licenses and governmental approvals desired by the Contractor for temporary Structures such as docks, piers, anchorages, etc. must be applied for and obtained by the Contractor at Contractor's sole cost and expense.

(c) Fire hydrant permits must be obtained if water is required from a hydrant. No water is to be drawn from a public fire hydrant except through a meter. Applications shall be made through the County Department of Permits, Approvals and Inspections (PAI), or any successor County department. All costs are considered incidental to the Bid, with the following exceptions:

The Department will issue a meter for fire hydrant utilization for performance of the Contract. At the request of the Contractor within five (5) Days of charging the lines the Engineer will issue the meter application to the Contractor without cost and there will be no charge for Contractor's water use recorded on the meter provided. Failure to return the meter in good condition, or utilization of the meter provided for any other purpose, will be grounds for assessment of replacement costs thereof and/or liquidated damages.

(d) A backflow valve must be used in drawing water from the metropolitan system for charging and testing new utilities.

(e) This General Provision only applies, in its entirety, to building Contracts. GP-7.02(e)(8), "Miscellaneous Permits" applies to all types of Contracts.

(1) **BUILDING PERMIT** – The County will obtain the building permit at no cost to the Contractor.

(2) **PERMANENT WATER AND/OR SEWER SERVICE** – The County will apply for the permanent water and/or sewer service and pay all related charges; i.e., water meter, water systems connection charge, water distribution charge and sewer systems connection charge. Total installation of the permanent water and/or sewer service is part of this Contract. Water and/or sewer service shall be installed by a County prequalified utility contractor.

(3) **PLUMBING PERMIT** – The Contractor shall apply for the plumbing permit; however, the County will pay all related charges and fees.

(4) **PERMANENT ELECTRIC SERVICE** – The Contractor shall apply for and pay for the electrical permit. The County shall obtain permanent gas and electric service from the applicable Utility Companies for the Work site at no cost to the Contractor.

The Contractor shall coordinate the installation of permanent gas and electric service with the applicable Utility Companies. Both the gas and electric services shall be activated at the same time under one account number showing the County as owner. The Contractor shall be responsible for payment of consumption charges for the use of gas and electric energy obtained through the permanent gas and/or electric service until Final Acceptance for Maintenance of the Contract Work or until agreed upon by the County in direct coordination with the Department's Building Services Division. Charges from the Utility Companies for removal of existing electric service will be paid by the County.

(5) PERMANENT TELEPHONE SERVICE – The County shall pay for the permanent telephone service and systems to and in any Contract building. The Contractor is responsible for supplying and installing all conduit, cables and junction boxes as shown on the Contract Drawings or as described in the Contract Documents.

(6) CABLE – The County shall pay for any permanent cable television service into any Contract building. The Contractor is responsible for supplying and installing the remaining Work as shown on the Contract Drawings or as described in the Contract Documents.

(7) TEMPORARY SERVICES – All temporary services, such as water, electric, telephone, etc., shall be the Contractor's entire responsibility.

The Contractor shall arrange for and pay for the installation of temporary connection to the County's water mains, including all incidental fees and expenses for water supply during Construction of the Contract Work, and shall pay for all water used. Wasting of County water will not be permitted.

The Contractor shall arrange for and pay for temporary electric light and power service required during Construction of the Contract Work, and shall pay for all electricity used. Gasoline or other torches for lighting will not be permitted.

The Contractor shall provide and pay for any other temporary services that may be required for the Full and Final Completion of the Contract Work.

The Contractor shall provide, at Contractor's sole cost and expense, all cold weather protection, temporary heat and fuel as necessary to carry on the Work expeditiously during inclement weather, to protect Work and Materials against injury from dampness and cold, to dry out the building, and to provide suitable Working conditions. Refer to other portions of these Standard Specifications and/or the Contract Documents for temperatures required for Work under the various trades.

The methods of heating and type of fuel and Equipment used shall be subject to approval by Engineer.

With special permission, obtained from the Engineer in writing, a permanent heating system may be used to dry out any Contract building and provide suitable working conditions in all or various parts thereof as soon as practicable. If used, the Contractor shall be

responsible for use of the permanent heating system for the purpose described and all costs of fuel, attendance, etc. in connection therewith shall be borne by the Contractor. Such use shall not relieve the Contractor of its responsibility to turn over the permanent heating system to County on the date of Final Acceptance for Maintenance in perfect condition, including the removal of all dust of Construction from air handling units, etc., the replacing of all filters, etc., nor shall it shorten the stipulated guarantee period which will commence upon the date of Final Acceptance for Maintenance by the County of the Work.

(8) MISCELLANEOUS PERMITS - The Contractor shall procure any and all necessary permits not previously mentioned and pay any and all related charges and fees required and incidental to the due and lawful prosecution of the Work.

(f) The Contractor shall give all notices and comply with all State and federal laws, ordinances, rules and regulations bearing on the conduct of the Work as drawn and specified.

GP-7.03 INTELLECTUAL PROPERTY AND PATENTED DEVICES, MATERIALS AND PROCESSES

If the Contractor is required or desires to use any intellectual property right, design, device, propriety information, material, or process covered by letters of patent or copyright or any other intellectual property right, the Contractor shall provide for such use by suitable legal agreement with the patentee, license holder, or owner and a copy of such agreement shall be filed with the Administration. The Contractor and the Surety shall indemnify, protect and save harmless (and defend upon request) the County and its officials, employees, agents and any affected third party, or political subdivision from any and all claims, suits, demands, liabilities, actions, costs, and/or judgments including, but not limited to, attorneys fees, by reason of the use of any such patented design, proprietary information, device, trade secret, patent right or intellectual property right or design, device, material, or process, or any trademark or copyright.

GP-7.04 FEDERAL OR STATE PARTICIPATION

When the United States Government and/or the State pays all or any portion of the cost of a project, the Work shall be subject to the inspection of the appropriate federal or State agency. Such inspection shall in no sense make the federal or State government a party to this Contract, and will not interfere in any way with the rights of either party hereinunder.

GP-7.05 CONSTRUCTION SAFETY AND HEALTH STANDARDS

(a) It is a condition of this Contract, and shall be made a condition of each Subcontract entered into pursuant to this Contract, that the Contractor and any Subcontractor shall not require any laborer or mechanic employed in performance of the Contract to work in surroundings or under working conditions which are unsanitary, hazardous, or dangerous to his health or safety, as determined under Construction safety and health laws, standards and regulations (Title 29,

Code of Federal Regulations, Part 1926, formerly Part 1518, as revised from time to time) promulgated by the United States Secretary of Labor, in accordance with Section 107 of the Contract Work Hours and Safety Standard Act, (83 Stat. 96) and under any Construction safety and health standards and regulations promulgated by the Commissioner of Labor and Industry in accordance with the Maryland Occupational Safety and Health Act and/or the Maryland General Assembly (as the same may be amended from time to time).

The Contractor and each Subcontractor shall permit inspection without delay and at any reasonable time on any premises where the Work is being performed by a federal or State inspector authorized to investigate compliance with the above mentioned federal and State statutes and regulations.

The Contractor further agrees to correct any violations found to exist during such inspection within a reasonable time after the issuance of any citation, unless the Contractor contests the validity thereof through the appropriate administrative and judicial process.

(b) The Contractor shall be responsible for gas detection in and ventilation of confined spaces.

When procedures require workers to enter confined spaces such as steel or concrete box section type Superstructures, the Contractor shall be cognizant of the potential health hazards, particularly when the interior is closed off at both ends.

It shall be the Contractor's responsibility to adhere to all applicable MOSHA regulations. The Contractor shall have available approved detecting devices and shall conduct tests for oxygen content and presence of gases, such as combustible gas, carbon dioxide, methane, carbon monoxide, and hydrogen sulfide whenever any fabrication, erection or inspection operations are to be performed within the confined spaces. The Contractor shall apply mechanical ventilation continuously to the confined space during occupancy to maintain the proper oxygen content. The Contractor shall conduct air tests periodically during the occupancy.

(c) The Contractor shall arrange for the erection and maintenance of temporary toilets equipped with running water and a drain connection for use of the Contractor's employees, Subcontractors, and/or agents, and County employees. These conveniences shall be erected and kept clean, neat and in good sanitary condition, as required by applicable law and/or regulation, until ordered removed by the Engineer.

In lieu of temporary toilets, the Contractor may install a portable chemical toilet at a location as approved by the Engineer.

The permanent plumbing fixtures to be constructed under the Contract shall not be used by any Person, under any circumstances, before Final Acceptance for Maintenance of the Contract by the County.

(d) The Contractor shall erect and properly maintain at all times as required by the conditions and progress of the Work, all necessary safeguards for the protection of workers and the public

and shall post danger signs warning against the hazards created by such features of Construction as protruding nails, hod hoists, well holes, elevator hatchways, scaffolding, window openings, stairways and falling material.

In an emergency affecting the safety of life, or of the Work, or of the adjoining property, the Contractor, without special instruction or authorization is hereby permitted to act, at the Contractor's discretion, to prevent such threatened loss or injury, and the Contractor shall so act, without appeal, if so instructed or authorized by the Engineer. Any compensation claimed by the Contractor on account of emergency Work shall be determined as outlined in GP-4.07.

GP-7.06 PUBLIC CONVENIENCE AND SAFETY

The Contractor at all times shall conduct the Work in such a manner as to ensure the least practicable obstruction to all forms of traffic. The convenience of the general public, tenants, and of the residents along and/or adjacent to the Work site shall be provided for as follows and as further directed by the Engineer:

- (a) Equipment and/or Materials stored upon or about the Work site shall be placed so as to cause a minimum of obstruction to the public.
- (b) Sprinkling shall be performed at the direction of the Engineer.
- (c) The Contractor shall, unless otherwise specified, provide and maintain in passable condition such temporary access, Roads and Bridges as may be necessary to accommodate traffic diverted from the Work site under Construction, or using the project under Construction and shall provide and maintain in a safe condition temporary approaches to and crossings of the Work site.
- (d) Existing facilities planned to be removed, but which might be of service to the public during Construction are not to be disturbed until other and adequate provisions are made.
- (e) Existing mailboxes shall be maintained or reset in positions accessible to the public and to mail deliveries during Construction and subsequent to Construction in their final locations in a satisfactory condition.
- (f) On facilities occupied by railroad or light rail stations, temporary platforms for the entrance and exit of passengers and/or freight to and from the railway cars shall be provided and maintained in an approved manner by the Contractor and the applicable railroad/agency.
- (g) Fire hydrants on or adjacent to the Contract Work site shall be kept accessible to fire apparatus at all times, and no material or obstruction shall be placed within fifteen (15) feet of any such hydrant. Work closed down for the winter or at any other times shall be left entirely accessible at all points to fire apparatus.

(h) All footways, gutters, storm drainage and portions of the Contract Work site adjoining the Work under Construction shall not be obstructed more than is absolutely necessary. The Engineer, in cooperation with the Sediment Control Inspector, shall specify that drainage inlets in sumps where there is potential for localized flooding shall have flow restrictions removed in the event of a predicted significant rainfall event.

GP-7.07 DETOURS

Detours may be indicated in the Contract Documents, or at the Contractor's request traffic may be detoured over County-approved routes along existing Roads, as determined acceptable by the Department's Bureau of Traffic Engineering and Transportation Planning. Detours over existing Roads will be designated, marked and maintained by the Contractor.

GP-7.08 BARRICADES AND WARNING SIGNS

The Contractor shall provide, erect and maintain all necessary barricades, suitable and sufficient lights, danger signals, signs and other traffic control devices, and shall take all necessary precautions for the protection of the Work and safety of the public. All Highways and other County facilities closed to vehicular traffic shall be protected by effective barricades, and obstructions shall be illuminated during hours of darkness with electric lights. The Contractor shall erect warning signs in advance of any place on the Work site where operations may interfere with the use of the facility by vehicular traffic, and at all other points where the new Work crosses or coincides with an existing Roadway or traffic lane(s). Such warning signs shall be constructed and erected in accordance with the MUTCD for Street and Highways, or as directed by the Engineer.

The Contractor shall furnish, erect and maintain warning and direction signs in the number required by the Engineer and at locations designated by the Engineer throughout the limits of the Contract Work site.

For street and Highway type traffic, the signs shall conform in every respect to the requirements of the MUTCD for Streets and Highways. Signs must be freshly painted and adequately reflectorized before being placed on any Contract Work site. No Work may be performed or begun unless an adequate number of signs of the proper category are in place.

In cases where the Contractor's sequence of operations results in grade differentials that would be hazardous to vehicular traffic the Contractor shall, at the direction of the Engineer, provide suitable substantial traffic barriers to the extent determined by the Engineer.

GP-7.09 FLAGGING OF MOTOR VEHICLE TRAFFIC

For all Construction Contracts requiring the flagging of motor vehicles licensed for operation on the Highways of the State, said flagging shall be conducted as specified in the MUTCD for Streets and Highways.

GP-7.10 MAINTENANCE OF TRAFFIC

Unless otherwise noted in the Special Provisions, it shall be the Contractor's responsibility to maintain pedestrian and vehicular traffic safely, adequately and continuously on all portions of existing facilities affected by the Contractor's Work. In addition to existing facilities undergoing improvement, this also applies to crossroads, approaches, crossovers and entrances affected or made necessary by the Contractor's Work.

GP-7.11 PRESERVATION AND RESTORATION OF PROPERTY OUTSIDE OF RIGHT-OF-WAY

(a) The Contractor shall not enter upon public or private property (outside of the Right-of-Way or Contract Work area as shown on the Contract Drawings) for any purpose without obtaining prior written permission from any applicable property owners. The Contractor shall be responsible for the preservation of all public and private property, trees, property pipes, monuments, signs and markers and fences thereon, and shall use every precaution necessary to prevent damage or injury thereto. The Contractor shall take suitable precaution to prevent damage to underground or overhead public utility structures. The Contractor shall carefully protect all survey land monuments and property marks located on the Contract Drawings or found in the Work site from disturbance. No alteration or damage thereto shall occur until survey references are established by a licensed surveyor at Contractor's sole cost and expense. If any land monuments and/or property marks are damaged or disturbed, they shall be reset by a licensed surveyor at the Contractor's sole cost and expense.

(b) The Contractor shall be responsible for all damage or injury to property of any character during the prosecution of the Work, resulting from any act, omission, neglect or misconduct in the Contractor's manner or method of executing said Work, or at any time due to defective Work or Materials, and said responsibility shall not be released until Final Acceptance for Maintenance of the Work is achieved. When or where any direct or indirect damage or injury is done to public or private property by or on account of any act, omission, neglect or misconduct in the execution of the Work or in consequence of the nonexecution thereof on the part of the Contractor, the Contractor shall restore, at the Contractor's sole cost and expense, such property to a condition similar to, or equal to, that existing before such damage or injury, in an acceptable manner to the County and/or applicable property owner. In case of the failure on the part of the Contractor to restore such property or make good such damage or injury, the Engineer may, upon forty-eight (48) hours notice to the Contractor, proceed to Repair, rebuild or otherwise restore such property as may be deemed necessary, and the cost and expense thereof will be deducted from any monies due or which may become due the Contractor under this Contract. If the property damage results in a public safety issue, in the sole discretion of the County, the

Contractor shall restore immediately or the County shall do so at Contractor's sole cost and expense.

(c) The Contractor should be aware of the potential of cultural resources on the Contract Work site. During the Construction phase, whenever anything that might appear to be a cultural resource of an historical, archeological, or paleontological nature is encountered, such an object shall not be disturbed. Work shall be stopped and rescheduled in a way that shall avoid not only the objects encountered but also the area of discovery and the Engineer shall be notified in writing at once. The Engineer will arrange for the evaluation of the situation by the appropriate authorities and for the ultimate disposition of the matter, taking the evaluation of the situation by the appropriate authorities into consideration.

(d) All trees along the way of access and all trees surrounding any Contract building which are liable to injury by the moving, storing and working up of Materials shall be boxed. No permanent tree shall be used for attachment of any ropes or derricks. Every public way, catch basin, conduit, tree, fence or things injured in carrying out this Contract, shall be replaced and put in good condition by the Contractor at no cost or expense to the County, unless the same shall be permanently done away with by written order of the Engineer.

GP-7.12 LAND, AIR AND WATER POLLUTION

(a) The Contractor shall incorporate all permanent erosion control features into the Work at the earliest practicable time as required by the Contract Documents. Temporary pollution control measures will be used to correct conditions that develop during Construction that were not foreseen during design; that are needed prior to installation of permanent pollution control features; or that are needed temporarily to control erosion that develops during normal Construction practices, but are not associated with permanent control features on the Contract.

(b) The Contractor's attention is directed to the fact that temporary pollution control may include control measures outside the Right-of-Way or Contract Work site where such Work is necessary as a direct result of Contract-required Construction. The Engineer shall be kept advised of all such off-site control measures taken by the Contractor. This shall not relieve the Contractor of the basic responsibilities for such Work.

(c) In case of failure on the part of the Contractor to control erosion, pollution or siltation, the Engineer reserves the right to employ outside assistance or to use County forces to provide the necessary corrective measures. All costs and expenses incurred by the Engineer in the performance of such duties for the Contractor shall be withheld from monies due or becoming due to the Contractor.

(d) The Contractor and the Contractor's suppliers must submit evidence to the Administration that the governing federal, State and local air pollution laws, regulations and criteria will be met. This evidence and related documents will be retained by the Administration for on-site evaluation.

GP-7.13 RESPONSIBILITY FOR DAMAGE CLAIMS

(a) The Contractor shall indemnify and save harmless the County and all of its officials, agents, employees and representatives from all suits, actions, or claims of any character, including, but not limited to, all the costs of defense, brought on account of any injuries or damages sustained by any person or property in consequence of any neglect in safeguarding the Work, and/or through the use of unacceptable Materials in the Construction of the Contract Work, and/or on account of any act or omission by the said Contractor in the performance of the Contract, and/or as a result of faulty, inadequate or improper temporary drainage during Construction, and/or on account of the use, misuse, storage or handling of explosives, and/or on account of any claims or amounts recovered for any infringement of intellectual property, patent, trade secret, proprietary information, trademark, or copyright, and/or from any claims or amounts arising or recovered under the workers' compensation laws, and/or any other State or local law, executive order, charter, bylaw, code, ordinance, regulation, order or decree whether caused by or resulting from the act, omission, neglect, or misconduct of the Contractor, or its employees, agents, or Subcontractors, at any tier. The Contractor shall be responsible for any and all damage or injury to property of any character during the prosecution of the Work resulting from any act, omission, neglect or misconduct, in the manner or method of executing said Work satisfactorily or due to the nonexecution of said Work or at any time due to defective Work or Materials and said responsibility shall continue until Full and Final Completion of the Contract. The obligation of the Contractor to the County and all of its officials, agents, employees and representatives to indemnify, defend, and save harmless shall not apply if resulting from the sole negligence of the County.

(b) The Contractor shall conduct its operations upon the right-of-way of any applicable railroad company fully within the rules, regulations and requirements of the railroad company including, but not limited to, any additional flagging, insurance, inspection, and/or permit requirements. The Contractor shall be responsible for acquainting itself with such requirements as the railroad company may demand.

(c) The Contractor shall be held solely responsible for any accidents that may happen to the railroad company as a result of its operations.

(d) In accordance with GP-7.15, the Contractor shall not be held responsible for any claims arising from accidents incurred because of any traffic or general use permitted during the time the Construction Work site or any section thereof is open to traffic except from accidents which are attributable to the Contractor's, or the Contractor's employee's, Subcontractor's or agent's, acts or omissions or negligence.

GP-7.14 LIABILITY INSURANCE

Prior to the start of the Work on the Contract, or prior to the execution of the Contract if permitted by the County, the Contractor shall submit to the Department's Division of

Construction Contracts Administration, an evidence of insurance certificate indicating that the following insurance is carried:

“Comprehensive general public liability and property damage insurance” in the amounts of at least five hundred thousand dollars (\$500,000) for the death of or injury to any person, each occurrence. Such insurance shall protect the Contractor from claims which may arise out of, or result from, the Contractor’s operations under the Contract, whether such operations be by the Contractor, any Subcontractor, or anyone directly or indirectly employed by the Contractor or Subcontractor, or anyone for those acts any of the above may be liable. Minimum coverages to be included: “independent contractor’s coverage”; “completed operations and products liability coverage”; and “contractual liability coverage”. “Damages not to be excluded insurance” shall contain no exclusions applying to operations by the Contractor or any Subcontractor in the performance of the Contract pertaining to: (1) collapse of, or structural injury to, any Contract building or Structure; (2) damage to underground property; or (3) damage arising out of blasting or explosion and, where applicable, (4) removal of asbestos/lead or debris and building products containing asbestos/lead, transportation and disposal of asbestos/lead and contaminated materials.

“Automobile liability insurance” shall include “bodily injury liability” and “property damage liability” for a combined single limit of five hundred thousand dollars (\$500,000) any one accident. Such insurance shall provide coverage for all Contractor owned, non-owned and hired automobiles.

“Workers’ compensation and employers’ liability insurance” must contain statutory coverage, including “employers’ liability insurance” with limits of at least for “bodily injury by accident” – two hundred fifty thousand dollars (\$250,000) each accident; “bodily injury by disease” – two hundred fifty thousand dollars (\$250,000) each employee; and “bodily injury by disease” – five hundred thousand dollars (\$500,000) policy limit.

Any policy exclusions must be shown on the face of the evidence of insurance.

When specified in the Contract Documents, the Contractor shall carry the type and amounts of insurance in addition to any other forms of insurance or bonds required under the terms of the Contract and the Contract Documents.

The cost of the insurance will be incidental to the Contract lump sum price for mobilization, or if that is not identified, to the other Contract Items specified in the Contract Documents.

Contractor shall procure **“railroad public liability and property damaged insurance”** and this insurance shall be provided by the Contractor as specified in TC-6.03.

The Contractor and its insurer shall immediately notify in writing the Department’s Division of Construction Contracts Administration in the event that the Contractor’s insurance coverage lapses for any reason.

Unless previously waived in writing by the Engineer, the Contractor shall, at the Contractor's sole expense and cost, insure the Work and keep it insured at all times during the Contract term and period of Construction, and until Final Acceptance for Maintenance of all Contract Work by the County, against loss or damage covered by an "all risk" builders risk type of policy. The amount of insurance shall be the one hundred percent (100%) estimated replacement cost of the Work.

The policies shall name the County and the Contractor as certificate holder and shall name the County as an additional insured in accordance with the requirements of the Contract Documents, as their interest may appear, and the policies shall be left in the possession of the Engineer, prior to the start of Construction.

GP-7.15 USE AND POSSESSION PRIOR TO FULL AND FINAL COMPLETION

(a) The Administration shall have the right to take possession of or use any completed or partially completed part of the Work. Such possession of or use shall not be deemed Partial Acceptance for Maintenance and/or Final Acceptance for Maintenance of any Work not completed in accordance with the Contract. While the Administration is in such possession, the Contractor shall be relieved of the responsibility for loss or damage to that portion of the Work in possession of the Administration, other than that resulting from the Contractor's fault, omission, act, or negligence. If such prior possession or use by the Administration delays the progress of the Work or causes additional expense to the Contractor, the Contractor shall provide the Administration with immediate Written Notice thereof to allow possible equitable adjustment in the Contract price or the time of completion. If necessary, an equitable adjustment will be made and the Contract shall be modified pursuant to a Contract Modification accordingly.

(b) Under this GP-7.15, only upon the prior written authorization of the Engineer may the Contractor be relieved of maintenance during the time the County has taken possession. Any portion of the Work that may be disturbed or damaged shall be restored at respective Contract prices for Contract Items involved, or on the basis of a predetermined arrangement entered into by the Contractor and Engineer before the performance of the restoration Work.

GP-7.16 CONTRACTOR'S RESPONSIBILITY FOR WORK

(a) Except as herein elsewhere provided, until Final Acceptance for Maintenance of the Work by the Administration, the Contractor shall have the charge and care thereof and shall take every reasonable precaution against injury or damage to any part thereof by the action of the elements, or from any other cause, whether rising from the execution or from the nonexecution of the Work. The Contractor, except as herein elsewhere provided, shall rebuild, Repair, restore, and make good all injuries or damages to any portion of the Work occasioned by any of the above causes before the Final Acceptance for Maintenance and shall bear the expense thereof. Material lost or Structures damaged as a result of faulty temporary drainage during Construction or the action of the elements shall be replaced or Repaired by the Contractor at no cost, expense, or delay to the Administration. The Contractor shall make good or replace at the Contractor's

cost and expense, and as otherwise required, any Administration-furnished Material which may be broken, lost through fire, theft, or otherwise damaged, or in any way made useless for the purpose and use intended subsequent to delivery to the Contractor by the Administration and prior to Final Acceptance for Maintenance of the Work by the County even though such breakage, damage, loss or uselessness may result from causes beyond the control of the Contractor.

(b) In case of suspension of Work for any cause whatever, the Contractor shall be responsible for the Contract Work and Work site and shall take such precautions as may be necessary to prevent damage to the Work and the Work site, provide for normal drainage, and shall erect any necessary temporary Structures, signs, or other facilities at the Contractor's cost and expense. During such period of suspension of Work, the Contractor shall properly and continuously maintain in an acceptable growing condition all living material in newly established plantings, seedings, and soddings furnished under this Contract, and shall take adequate precautions to protect new growth and other important vegetative growth against injury.

GP-7.17 CONTRACTOR'S RESPONSIBILITY FOR UTILITY PROPERTY AND SERVICES

At points where the Contractor's operations are adjacent to properties of railway, telegraph, telephone, power companies, and/or Utility Companies or are adjacent to other property, damage to which might result in expense, loss or inconvenience, Work shall not be commenced until all arrangements necessary for the protection thereof have been made between the Contractor and the property owner and/or affected Person.

The Contractor shall cooperate with the owners of any underground or overhead utility lines in their removal and rearrangement operations in order that these operations may progress in a reasonable manner, that duplication or rearrangement Work may be reduced to a minimum and that services rendered by those parties will not be unnecessarily interrupted.

In the event of interruption to utility services as a result of accidental breakage or as a result of being exposed or unsupported, the Contractor shall promptly notify the proper authority and shall cooperate with the said authority in the restoration of service. No Work shall be undertaken around fire hydrants until provisions for continued service have been approved by the local fire authority.

GP-7.18 PERSONAL LIABILITY OF PUBLIC OFFICIALS

In carrying out any of the provisions of the Contract, or in exercising any power or authority granted to them by or within the scope of the Contract, there shall be no liability upon the Administrator, Engineer or other County officials, employees, agents and/or authorized representatives, either personally or as officials, employees, or agents of the County, it being understood that in all such matters they act solely as agents and representatives of the County.

In addition, the Engineer and all of Engineer's representatives shall be held harmless, free of liability and duress, in the exercise of their duties and obligations as Inspector, administrator, witness, referee, mediator, and arbiter by both parties in their mutual best interest.

GP-7.19 NO WAIVER OF LEGAL RIGHTS

The Administration shall not be precluded or estopped by any measurement, estimate, or Certificate made either before or after the Partial Acceptance for Maintenance and/or Final Acceptance for Maintenance of any Work and payment therefore by the County, from showing the true amount and character of the Work performed and Materials furnished by the Contractor, nor from showing that any such measurement, estimate or Certificate is untrue or is incorrectly made, nor from showing that the Work or Materials do not in fact conform to the Contract. The Administration shall not be precluded or estopped, notwithstanding any such measurement, estimate or Certificate and payment in accordance therewith, from recovering from the Contractor or its Sureties, or both, such damage as it may sustain by reason of Contractor's failure to comply with the terms of the Contract. Neither the acceptance by the Administration, or any representative of the Administration, nor any payment for or acceptance of the whole or any part of the Work, nor any extension of time, nor any possession taken by the Administration, shall operate as a waiver of any portion of the Contract or of any power herein reserved, or of any right to damages.

No failure or delay by the County to insist upon the strict performance of any term, condition or covenant within the Contract, or to exercise any right, power, or remedy consequent upon a breach thereof, shall constitute a waiver of any such term, condition, or covenant or of any such breach, or preclude the County from exercising any such right, power, or remedy at any later time or times. Further, the express written waiver of any breach of the Contract shall not be a waiver of any other or subsequent breach of the Contract.

GP-7.20 NONDISCRIMINATION IN EMPLOYMENT

(a) The Contractor shall agree to the following conditions during the performance of its Contract with the County:

(1) To comply with all applicable federal, State, and County laws, regulations, codes, circulars, and executive orders;

(2) Not to discriminate in any manner against an employee or applicant for employment because of race, color, religion, creed, age, sex, marital status, national origin, ancestry, or physical or mental handicap unrelated in nature and extent so as reasonably to preclude the performance of such employment;

(3) To include a provision similar to that contained in GP-7.20 (a)(2), above, in any Subcontract except a Subcontract for standard commercial supplies or raw Materials;

(4) To post and to cause Subcontractors to post in conspicuous places available to employees and applicants for employment, notices setting forth the substance of this GP-7.20;

(5) In all solicitations or advertisements for employees placed by or on behalf of the Contractor, to state that all qualified applicants will receive consideration for employment without regard to sex, race, creed, color or national origin;

(6) If requested by the County to furnish a compliance report concerning its employment practices and policies in order for the County to ascertain compliance with the provisions of this Contract concerning nondiscrimination in employment; and

(7) To include the provisions outlined in this GP-7.20 pertaining to nondiscrimination in employment in every Subcontract or purchase order it uses in order to carry out the terms and conditions of the Contract so that such nondiscrimination in employment provisions are binding on each Subcontractor or vendor.

(b) In the event of the Contractor's noncompliance with the nondiscrimination provisions of this GP-7.20 and/or the Contract, the County shall impose such sanctions as it may determine to be appropriate, including but not limited to:

(1) Withholding of payment to the Contractor under the Contract until the Contractor complies; and/or

(2) Cancellation, termination or suspension of the Contract in whole or in part.

(c) Contractors providing Materials, Equipment, supplies, or services to the County under this Contract herewith assure the County that they are conforming to the provisions of the Civil Rights Act of 1964 and Section 202 of the Executive Order 11246 of the President of the United States of America as amended by Executive Order 11375, as applicable and as may be amended from time to time.

GP-7.21 SANCTIONS UPON IMPROPER ACTS – Reserved.

GP-7.22 NONHIRING OF EMPLOYEES

No official or employee of the County or any unit, department or agency of the County, whose duties as such official or employee include matters relating to or affecting the subject matter of this Contract, shall, while so appointed and/or employed, and during the pendency and/or term of the Contract, become or be an officer or employee of the Contractor.

GP-7.23 CHOICE OF LAW

The Parties hereby agree that:

(a) This Contract was made and entered into in Maryland, and under the laws, regulations, codes, and executive orders of the County and the State, as applicable.

(b) The laws, regulations, codes and executive orders of the County and the State shall govern the resolution of any issue arising in connection with this Contract including, but not limited to, all questions concerning the validity of this Contract; the capacity of the parties to enter therein; any modification or amendment thereto; and the rights and obligations of the parties hereunder.

GP-7.24 CONTINGENT FEE PROHIBITION

(a) The Contractor warrants that it has not employed or retained any Person, partnership, corporation, or other entity, other than a bona fide employee or agent working for the Contractor, to solicit or secure this Contract, and that it has not paid or agreed to pay any Person, partnership, corporation, or other entity, other than a bona fide employee or agent, any fee or any other consideration contingent on the making of this Contract.

(b) For a breach or violation of this warranty, the Administration shall have the right to terminate this Contract without liability, or, in its discretion, to deduct from the Contract price or consideration, or otherwise recover, the full amount of such fee, commission, percentage, brokerage fee, gift or contingent fee.

GP-7.25 MULTI-YEAR CONTRACTS CONTINGENT UPON APPROPRIATIONS

– Reserved.

GP-7.26 COST AND PRICE CERTIFICATION – Reserved.

GP-7.27 CORPORATE REGISTRATION AND TAX PAYMENT CERTIFICATION

– Reserved.

GP-7.28 BUY AMERICAN STEEL ACT

The Provisions of COMAR 21.11.02 pertaining to implementation of the “Buy American Steel” Act (Subtitle 3 of Title 17 of the State Finance and Procurement Article of the Annotated Code of Maryland), as amended from time to time, are incorporated in this Contract by reference.

GP-7.29 MINORITY BUSINESS ENTERPRISE AND WOMEN BUSINESS ENTERPRISE

It is the policy of the County that MBE and WBE, as defined by the most recent County Executive Order, and as further described in the Contract Documents, shall have the maximum opportunity to participate in the performance of capital improvement contracts financed by County capital funds and/or County operating funds in accordance with the most recent County Executive Order. The Contractor shall comply with all MBE/WBE requirements as set forth in the Contract Documents.

GP-7.30 PREVAILING WAGE CONTRACTS FOR PUBLIC WORKS

(a) The Provisions of Subtitle 2 of Title 17 of the State Finance and Procurement Article of the Annotated Code of Maryland, as amended, and COMAR 21.11.11, as amended, pertaining to the Prevailing Wage for Public Works are incorporated in construction contracts of five hundred thousand dollars (\$500,000) or more by reference, if and as applicable.

(b) When all or a portion of the cost of a contract is funded by the U.S. Government, and the cost of the contract exceeds two thousand dollars (\$2,000), among other legal requirements, the minimum wage rates and benefits paid to workmen under the contract shall be those prevailing in the locality, as predetermined by the Secretary of Labor pursuant to the Davis-Bacon Act (40 USC 276a to a-7), as amended from time to time, and regulations (29 CFR, Part 5) promulgated thereunder, as amended from time to time. Davis-Bacon rates applicable to this Contract, if any, may be specified elsewhere in the Contract Documents.

GP-7.31 SMALL BUSINESS PROCUREMENTS – Reserved.

GP-7.32 FINANCIAL DISCLOSURE – Reserved.

GP-7.33 POLITICAL CONTRIBUTION DISCLOSURE

The Contractor affirms that it is aware of, and will comply with, the provisions of Sections 14-101 through 14-108 of the Election Law Article of the Annotated Code of Maryland, as amended from time to time, which requires every Person who makes, during any 12-month period, one or more contracts, with one or more State governmental entities involving cumulative consideration, of a least two hundred thousand dollars (\$200,000.00), to file with the State Board of Elections certain specified information to include disclosure of attributable political contributions in excess of five hundred dollars (\$500.00), during defined reporting periods.

GP-7.34 CONFLICT OF INTEREST LAW

It is unlawful for any County official, employee, or agent to participate personally in his/her official capacity through decision, approval, disapproval, recommendation, advice, or investigation in any contract or other matter in which he or she, his or her spouse, or his or her dependent child has a financial interest or to which any firm, corporation, association, or other organization in which he or she has a financial interest or in which he or she is serving as an officer, director, trustee, partner, or employee is a party, or to which any person with whom he or she is negotiating or has any arrangement concerning prospective employment, is a party, unless such official, employee, or agent has previously complied with the provisions of Article 7 of the Baltimore County Code, 2003, as amended.

GP-7.35 PRE-EXISTING REGULATIONS – Reserved.

GP-7.36 RETENTION OF RECORDS

(a) Except as otherwise expressly stated in this General Provision and the Contract Documents, the Contractor shall retain and maintain all records and documents including, but not limited to, cost or pricing data, relating to this Contract for three (3) years after final payment by the County under the Contract or any applicable statute of limitations, whichever is longer, and shall make them available for inspection and audit by authorized representatives of the County, including the Engineer or his designee at all reasonable times. Should the Contract involve use of State or federal funds, the Contractor shall retain and maintain, all records and documents including, but not limited to, cost or pricing data, relating to this Contract for not less than ten (10) years after final payment by the County under the Contract or any applicable statute of limitations, whichever is longer.

(b) The Contractor shall include the provisions of GP-7.36(a) in every Subcontract.

GP-7.37 RESPONSIBILITY FOR RIGHT OF WAY

(a) The Right-of-Way (or Work site) as shown on the Contract Drawings has been, or will be, secured by the County.

(b) The Contractor shall not move any Equipment or Material in or on the Right-of-Way until authorized to do so by the Engineer. The Contractor shall confine its operations strictly within the limits of the Rights-of-Way shown in the Contract Documents unless the Contractor obtains the prior written permission of any applicable property owner of such additional lands as Contractor proposes to occupy. A copy of the written permission will be furnished to the Engineer before Contractor enters said property.

(c) Unless otherwise provided in the Contract Documents, trees with a butt diameter in excess of three inches (3"), measured three feet (3') above the ground, shall not be felled or damaged by the Contractor in a Right-of-Way identified as a Construction Strip. Should the Contractor obtain written permission of any applicable property owner to fell a tree or trees with

a diameter greater than three inches (3") from a Construction Strip, Contractor shall provide a copy of the written permission to the Engineer before Contractor enters said property and/or fells such tree(s).

(d) Unless otherwise provided in the Contract Documents, all trees may be felled with the permission of the Engineer in those Rights-of-Way identified as a Highway Right-of-Way or a slope, utility or drainage Easement.

(e) Unless otherwise provided in the Contract Documents, the Contractor is to preserve and protect, remove and replace, or restore fences, mail boxes, Sidewalks, driveways, shrubs, perennial plants, or other private improvements in Rights-of-Way identified as Construction Strips or Easements of any kind.

(f) The Contractor shall not enter upon public or private property (outside of the Right-of-Way or Contract Work area as shown on the Contractor Drawing) for any purpose without obtaining prior written permission from any applicable property owners and shall be responsible for the preservation of all public and private property, trees, property pipes, monuments, signs and markers and fences thereon, and shall use every precaution necessary to prevent damage or injury thereto. The Contractor shall take suitable precaution to prevent damage to underground or overhead public and private utility structures. The Contractor shall carefully protect from disturbance all survey land monuments and property marks located on the Contract Drawings or found in on, or at the Work site. No alteration or damage thereto shall occur until survey references are established by a licensed surveyor at Contractor's sole cost and expense. If any land monuments and/or property marks are damaged or disturbed, they shall be reset by a licensed surveyor at the Contractor's sole cost and expense.

(g) Upon Final Acceptance for Maintenance of the Work by the County, the Contractor shall restore the Rights-of-Way provided to a condition equivalent to that originally encountered, unless improved by the Work completed or as specified by the Contract. Property used by the Contractor under letter of permission or property that has been damaged shall be restored pursuant to GP-7.11 and the applicable letter of permission or to the satisfaction of the property owner without any cost or expense to the County.

(h) No arrangements will be made by the County for rights-of-way or rights of access beyond those shown in the Contract Documents. Any and all expense or costs relative to additional rights-of-way, rights of ingress and egress, or any other supplemental property rights beyond those described in the Contract Documents are considered to have been accounted for in the Bid.

GP-SECTION 8 PROSECUTION AND PROGRESS

GP-8.01 SUBCONTRACTING

(a) Utilities and/or Highways Contracts. Except as may be provided elsewhere in the Contract, the Contractor to whom a utilities and/or Highways Contract is Awarded shall perform with its own organization and with the assistance of workmen under the Contractor's immediate supervision, Work of a value of not less than fifty percent (50%) of the total Bid value of the Contract. The Director may permit the Contractor to sublet or Subcontract Work in excess of the fifty percent (50%) limitation where it is determined by the Engineer that the best interest of the County will be promoted thereby. The execution of Work by a subsidiary of the Contractor is not considered to be Work performed by the Contractor under this GP-8.01(a). The Contractor shall not assign any monies due or to become due to the Contractor hereunder, without the previous written consent of the County.

The Engineer's consent to Subcontract shall not be construed to relieve the Contractor or its Surety of any responsibility for the fulfillment of all the requirements of the Contract.

Unless required by the County pursuant to GP-8.01(e) or unless specified in the Contract Documents, Subcontractors undertaking a portion of Work under a utilities or Highways Contract in accordance with GP-8.01(a) (less than fifty percent (50%) of the Bid value) do not require Department approval.

When required, the Contractor shall give assurance that the minimum wage for labor, as specified in the Contract Documents, shall apply to labor performed on all Work sublet, subcontracted, assigned or otherwise disposed of in any way under a utilities or Highway Contract.

(b) Buildings Contracts. Except as may be provided elsewhere in the Contract, the contractor to whom a buildings Contract is Awarded shall perform with its own organization, and with the assistance of workmen under the Contractor's immediate supervision and with Materials directly purchased and paid for by the Contractor, Work of a value of not less than ten percent (10%) of the total Bid value of the Contract. Costs for insurance, overhead, and supervisions may not be claimed as a portion of the ten percent (10%) or more of the Work. The execution of Work by a subsidiary of the Contractor is not considered to be Work performed by the Contractor under this GP-8.01(b). The Contractor shall not assign any monies due or to become due to the Contractor hereunder, without the previous written consent of the County.

The Engineer's consent to Subcontract shall not be construed to relieve the Contractor or its Surety of any responsibility for the fulfillment of all the requirements of the Contract.

Unless required by the County pursuant to GP-8.01(e) or unless specified in the Contract Documents, Subcontractors undertaking a portion of Work under a building Contract in accordance with GP-8.01(b) (less than ten percent (10%) of the Bid value) do not require Department approval.

When required, the Contractor shall give assurance that the minimum wage for labor, as specified in the Contract Documents, shall apply to labor performed on all Work sublet, subcontracted, assigned or otherwise disposed of in any way under a building Contract.

(c) **All Contracts.** The Contractor shall not assign any of its obligations, responsibilities, or liabilities under any portion of the Contract except with the express prior written consent of the Engineer. Any assignment of any of the Contractor's obligations responsibilities, or liabilities under any part of the Contract without the express prior written consent of the Engineer shall be null and void. Along with any applicable legal documentation to be signed by all applicable parties, any approved assignee must provide the County with (1) an executed Contract specifying the Contract Items and dollar volume of the Work to be performed by the assignee, (2) a Payment Bond and a Performance Bond as required pursuant to GP-3.03, and (3) a certificate of insurance as required pursuant to GP-7.14.

(d) **All Contracts.** For purposes of documentation and the County's file, the Contractor shall provide the County with Written Notice of all Subcontractors' names, and the amount or percent of the Bid value of the Contract and/or the Contract to be performed by each named Subcontractor, at or before time of Notice to Proceed.

(e) **All Contracts.** At any time after the County's issuance of the Bid Package, the County expressly reserves the right, for purposes of County approval and/or rejection, to require the Contractor to provide the County with Written Notice of all Subcontractors' names, and the amount or percent of the Contract to be performed by each named Subcontractor, and the names for such material men, suppliers, and others as the Engineer may direct, within ten (10) Business Days upon request by the County therefore. The Engineer shall review the Contractor's Written Notice under this GP-8.01(e) in a timely manner and inform the Contractor in writing of those Subcontractors approved by the Engineer for use on the Contract. If any Subcontractor is rejected in writing by the Engineer, such Subcontractor shall not work on the Contract Work. Prior to any Engineer approval, the Engineer may request the Contractor and any Subcontractor to meet additional criteria as specified by the Engineer in writing or in a Contract Modification. If the County requests Written Notice under this GP-8.01(e), the Contractor shall employ only those Subcontractors as may be approved in writing by the Engineer. No substitutions or further Subcontracting shall be employed by the Contractor without prior written approval from the Engineer. Approved Subcontractors shall not Subcontract principal or important parts of their Work, as determined in the County's sole discretion, without the Engineer's prior written approval.

The Engineer's approval of a Subcontractor under this GP-8.01(e) is only for Work to be prosecuted under the Contract and said approval is not applicable to any other contract with the County.

The Engineer reserves the express right to revoke approval of any Subcontractor for that Subcontractor's breach of any Contract provision, including, but not limited to, GP-8.06.

The Contractor agrees to be fully responsible to the County for the acts and omissions of its employees, Subcontractors and, of Persons either directly or indirectly employed by Contractor, and their respective employees and agents. The Contractor shall not assign this responsibility to any Person, except as provided in GP-8.01(c).

The Contractor shall incorporate by reference or otherwise include these General Provisions in every Subcontract issued pursuant to or under this Contract, and shall require that the same reference or inclusion be contained in every Subcontract entered into by any of its Subcontractors, at any tier.

(f) All Contracts. The Contractor agrees to bind every Subcontractor and every Subcontractor agrees to be bound by the terms of the Contract, the Standard Specifications, the Standard Details, the Special Provisions, the Contract Drawings and the Contract Documents, as far as applicable, to the Work.

The Subcontractor agrees to be bound to the Contractor by the terms of the Contract, the Standard Specifications, the Standard Details, the Special Provisions, the Contract Drawings and the Contract Documents and to assume towards the Contractor all obligations and responsibilities that the Contractor, by those documents, assumes towards the County.

The Contractor agrees to be bound to the Subcontractor by all the obligations the County assumes to the Contractor under the Contracts, the Standard Specifications, the Standard Details, the Special Provisions, the Contract Drawings, and the Contract Documents and by all the provisions thereof affording remedies and redress to the Contractor from the County.

(g) All Contracts. The Contractor shall pay its Subcontractors:

(1) Upon receipt of payment, as described in Section GP-9.03, the amount allowed to the Contractor on account of that Subcontractor's Work, to the extent of that Subcontractor's interest herein.

(2) Upon the receipt of payment, if issued otherwise than as described in Section GP-9.03, so that at all times the total payments shall be as large in proportion to the value of the Work done by the Contractor as the total amount certified to the Contractor is to the value of the Work done by that Subcontractor.

(3) To such extent as may be provided by the Contract Documents or any related Subcontracting documents, if either of these provides for earlier or larger payments than described in GP-8.01(g)(1) and (2).

(4) On demand for that Subcontractor's Work or Materials as far as executed and fixed in place, less the retained percentage, at the time the payment is requested, even though the Engineer fails to approve it for any cause not the fault of that Subcontractor.

(5) To give that Subcontractor an opportunity to be present and to submit evidence in any manner involving that Subcontractor's rights under the Contract.

The Contractor and the Subcontractor agree that nothing in this GP-8.01(g) shall create any obligation on the part of the County to pay any Subcontractor or to see to the payment of any sums to any Subcontractor. County has no obligation or liability of any kind, nature or amount to any Subcontractor. Nothing contained in the Contract, or any related Subcontracting

documents, shall create any contractual relationship between any Subcontractor, materialman, supplier, and/or other party and the County.

GP-8.02 NOTICE TO PROCEED

(a) Unless otherwise stated in the Contract Documents, upon execution of the Contract and within ninety (90) Calendar Days from the date of Award, the Department's Division of Construction Contracts Administration will issue to the Contractor a "Notice to Proceed" and this notice will stipulate when the Contractor is expected to begin Work. The specified Contract Time shall begin on the date stipulated in the Notice to Proceed or, if an earlier start is authorized in the Notice to Proceed, on the Day Work (other than the erection of the inspection office, Construction stakeouts and mobilization) actually starts. Work done prior to receipt of the Notice to Proceed is unauthorized and will not be measured or paid for.

(b) If the County is unable to issue the Notice to Proceed within ninety (90) Calendar Days from the Award of the Contract, and the County has not yet executed the Contract, the Contractor may request that the County rescind the Notice to Proceed, it being mutually understood that in such instance and upon such rescission, the County shall have no further obligation or liability to Contractor of any nature, kind or amount. If the County is unable to issue the Notice to Proceed within ninety (90) Calendar Days from the Award of the Contract, and the Contract was executed by the Contractor and the County, the Contractor may request that the County rescind the Contract, it being mutually understood that in such instance and upon such rescission, the County's obligations and liabilities shall be limited to the net documented cost of Materials actually fabricated and/or delivered to the Work site of the Contract preauthorized in writing by the Engineer. The County's remedies shall be in accordance with the Contract Documents, at law and/or in equity.

(c) The County has no obligation or duty to remit payment for any Materials prior to the County's execution of the Contract. Any Material paid for by the County after a notice of Award will become the property of the County.

(d) **Emergency Roster.** Each successful Contractor must furnish the Engineer with the names, addresses and telephone numbers of at least two (2) members of the Contractor's organization who may be contacted in an emergency.

GP-8.03 PROSECUTION OF THE WORK/DETERMINATION & EXTENSION OF CONTRACT TIME

(a) The Contractor shall begin Work promptly within the time specified by the Engineer in the Notice to Proceed and shall notify the Engineer at least forty-eight (48) hours before starting Work. The Contractor shall complete the Work and achieve Full and Final Completion within the number of Working Days, Calendar Days or Calendar Date, as specified in the Contract.

The Engineer will make available to the Contractor each week a record showing the number of Days charged to the Contract for the preceding week. The Contractor will be allowed one week in which to protest and thirty (30) Days in which to file a written statement, setting forth in what respects time charges are incorrect.

(b) If Full and Final Completion of the Contract, including all extensions and increases authorized under GP-4.04 and changes specified in the General Provisions and Interim Supplemental Specifications, requires the performance of Work in greater quantities than specified in the Contract, as determined by the Engineer, the Contract Time allowed for Contract performance may be adjusted based on the quantities, cost and the nature of the Work involved.

(c) The Contractor, under certain conditions, may be granted permission or ordered to suspend operations as defined in GP-8.07 "Suspension of Work". On a Working Day Contract, if the Contractor elects and is permitted by the Engineer to do any Work during a suspension period, the Working Days charged shall be based on the "daily value" of the Contract, which shall be calculated as the Bid price of the Contract divided by the number of Working Days allowed by the Contract Time. At the end of each month during any suspension period, the amount of money earned for that month will be divided by the "daily value" (as defined above) to determine the number of Working Days to be charged for that month (number of Working Days to be rounded down). However, the resultant number of Working Days to be charged for any particular month will never exceed the number of Calendar Days for that month, excluding Saturdays, Sundays or Holidays on which no Work was performed by the Contractor on a Pay Item and/or a Controlling Operation.

Time used in performing Work of an emergency nature ordered by the Engineer for the convenience of the traveling public or for the production or delivery of Materials for storage, if performed during the period of suspension, will not be charged against the Contract Time.

(d) Following the date on which Partial Acceptance for Maintenance has been achieved for all Work, except those landscaping Contract Items on which Work is restricted to specified seasons and when inspection and Final Acceptance for Maintenance is being deferred pending completion of those landscaping Contract Items because such Work is currently out of season, and for no other reason, no time will be charged against the Contractor until such time as it is again permissible to proceed with such landscaping Work. However, time will be charged during any extensions of the specified season documented by the County and which may be granted the Contractor.

(e) **Prosecution of the Work shall not be discontinued without the prior written approval of the Engineer.** After the Work has started, the Contractor shall prosecute the Work continuously within the Contract Time without stoppage until Final Acceptance for Maintenance of all Contract Work is achieved and the Contractor achieves Full and Final Completion.

(f) Should the prosecution of the Work for any reason be discontinued without the prior written approval of the Engineer, the Contractor shall immediately notify the Engineer in writing of Contractor's intention to stop and the County may exercise any and all rights pursuant to the Contract, at law and/or equity.

GP-8.04 PROGRESS SCHEDULE REQUIREMENTS

(a) General.

(1) Scheduling of Construction is the responsibility of the Contractor. The Contractor must take all reasonable action to avoid or to mitigate the effects of delays including, but not limited to, rescheduling or resequencing the Work, accepting other work, and reassigning personnel. When the Contractor is responsible for any delays, the County may order the Contractor to accelerate Construction, work overtime, add additional shifts or manpower, work on weekends, or to do anything else reasonably necessary to achieve Full and Final Completion of the Work within the Contract Time, at no additional cost to the County.

(2) The Contractor shall submit to the County for review and approval a baseline schedule, monthly progress schedules, and any required recovery schedules as outlined in this GP-8.04.

(3) Failure of the Contractor to comply with the requirements of this GP-8.04 shall be grounds for determination by the County that the Contractor is not prosecuting the Work with due diligence as to ensure Full and Final Completion of the Work within the Contract Time specified in the Contract Documents or as agreed upon with the County after execution of the Contract. Based on this determination, the County may terminate the Contractor's right to proceed with the Work, or any separable part thereof, in accordance with GP-8.08 of these Standard Specifications.

(4) The Contractor does not have the unilateral right to complete the Work late and to then pay liquidated or other damages as a proposed remedy to this lateness.

(b) Baseline Schedule.

(1) Within thirty (30) Days after the Award of the Contract, the Contractor shall submit to the Department a detailed baseline schedule indicating the time allocated by the Contractor for performance of each portion of the Work. The baseline schedule shall show commencement of Work from the date the Notice to Proceed is issued. The baseline schedule shall show Full and Final Completion of the Work within the Contract Time as specified in the Contract or as mutually agreed upon with the County in writing pursuant to a Contract Modification after execution of the Contract.

(2) The submitted baseline schedule shall be properly and reasonably sequenced to show the order of performing the various tasks of Work. The baseline schedule shall clearly identify the sequencing restraints and the critical activities necessary to complete the Work and achieve Full and Final Completion of the Work within the Contract Time, and shall list proposed Work Days, Holidays and any special non-Work Days.

(3) The submitted baseline schedule shall list the dollar value for each Contract Item and shall show the Contractor's labor requirements for achieving each Contract Item. The baseline schedule shall also include a list of submittals related to Material and Equipment fabrication orders, permits, Easements and any other Work tasks requiring submittals. Each necessary submittal shall be shown on the baseline schedule as a separate Work activity with necessary dates of submittal, anticipated review and response time, anticipated dates of re-submittal if necessary, and anticipated dates for final review and approval.

(4) Within fourteen (14) Calendar Days after the Engineer reviews and rejects or conditionally approves the submitted baseline schedule, the Contractor shall make all necessary corrections and resubmit the corrected baseline schedule. The County may decline to issue a Notice to Proceed until the Contractor submits the required baseline schedule in form and content acceptable to the County in the County's sole discretion.

(c) Monthly Progress Schedules.

(1) Within thirty (30) Days after the County issues Notice to Proceed, and on a monthly basis thereafter, the Contractor shall submit a monthly progress schedule accurately updated to reflect Contract Work performed to date since the previously submitted monthly progress schedule including, but not limited to, actual commencement dates of listed Work activities, actual Work activities completed to date, and any sequence changes made or planned for the order of Work activities and their effect on the critical path for Full and Final Completion of the Contract. The sequencing changes shall show extension of times granted in a Contract Modification by the County and any delays or early completion of Work activities.

(2) The Contractor shall, and it is the Contractor's obligation to, meet with the Engineer, or his designee, at least once a month to discuss in detail the Contractor's updating of the monthly progress schedule and the necessity for revision or correction in the monthly progress schedule.

(3) Within ten (10) Calendar Days after the County reviews and rejects or conditionally approves the submitted monthly progress schedule, the Contractor shall make all necessary corrections and resubmit the corrected monthly progress schedule in form and content acceptable to the County in the County's sole discretion.

(4) The Contractor shall submit the required monthly progress schedule whether or not the Contractor submits an application for payment each month. The County may decline to process any pending payment requests under the Contract unless and until the Contractor submits the required monthly progress schedule in form and content acceptable to the County, in the County's sole discretion, and the Engineer approves such schedule in writing.

(d) Recovery Schedules.

(1) At all times during the Contract term, within ten (10) Calendar Days after the Contractor falls behind a baseline schedule or a monthly progress schedule, or is alleged by the County to be behind a baseline schedule or a monthly progress schedule, the Contractor shall

furnish to the County, at no additional cost, a recovery schedule. The recovery schedule shall show how the Contractor will finish the Contract Work and achieve Full and Final Completion by the Contract Date.

(2) The recovery schedule shall include all of the information required under GP-8.04(c).

(e) Logical Sequencing and Layout of the Submitted Schedules (CPM Schedules).

(1) Unless the Contract Documents expressly permit the Contractor to use a type of schedule other than a Critical Path Method (CPM) schedule, the submitted baseline schedule, the monthly progress schedules, and any required recovery schedules shall all be CPM schedules.

(2) CPM schedules are required to assure and to monitor the Contractor's adequate planning and execution of the Work and to assist in the County's evaluation of the Contractor's progress of the Work and the impact on the Completion Date.

(3) The submitted CPM schedules shall clearly designate the dates of Final Acceptance for Maintenance and Full and Final Completion of the Contract Work. **THE CONTRACTOR'S ACHIEVEMENT OF FINAL ACCEPTANCE FOR MAINTENANCE DOES NOT RELIEVE THE CONTRACTOR OF ANY OBLIGATION OR RESPONSIBILITY TO ACHIEVE FULL AND FINAL COMPLETION OF ALL CONTRACT WORK BY THE COMPLETION DATE.**

(4) As part of the CPM schedule format, the Contractor shall include logic or network diagrams showing the order and interdependence of activities and the sequence in which Work is to be accomplished as planned by the Contractor. These diagrams must show how the start of a given activity is dependent on preceding activities and how its completion restricts the start of the following activities.

(5) At a minimum, the following information shall be furnished for each Work activity in any and all schedules provided under this GP-8.04:

- i. Activity number
- ii. Description of activity
- iii. Activity numbers for any predecessor and successor activities
- iv. Relationships with preceding activities
- v. Activity duration in calendar days
- vi. Percent of activity completed
- vii. Early start date (by Calendar Date)
- viii. Early finish date (by Calendar Date)
- ix. Actual start date (by Calendar Date)
- x. Actual finish date (by Calendar Date)
- xi. Float or slack (by Calendar Date)

(6) The Contractor's monthly progress schedules and any required recovery schedules shall show the activities or portion of the activities completed during the reporting period and their total dollar value as basis for the Contractor's periodic request for payment. For each activity, the update shall state the percentage of Work actually completed and the progress along the critical path in terms of Days ahead or behind the allowable dates.

(7) The Contractor's monthly progress schedules and any required recovery schedules shall include a comments section summarizing the updated analysis for the Contract Work as a whole, describing any and all problems with Work activities, and explaining proposed corrective actions.

(8) Approved Change Orders shall be reflected as new activities or as change in logic and/or time framing of existing activities. Approved Change Orders shall be shown on the Contractor's applicable updated schedule that immediately follows the Contractor's receipt of a Change Order approval from the County.

(9) The Contractor shall hold bi-weekly progress meetings, or more frequently if required by Engineer, at the Work site, at a time suitable to the Engineer, at which the progress of the Work shall be reported upon in detail with reference to all applicable schedules. Each interested Subcontractor shall be required to have present a competent representative to report the condition of the Subcontractor's portion of the Work and to receive instructions. Minutes of these progress meetings shall be taken by the Contractor who shall type them for distribution to members of the meeting, the Department's Division of Construction Contracts Administration, the Department's Bureau of Engineering and Construction, and other interested persons. These minutes shall be received by all parties prior to the next scheduled progress meeting and will be revised by the Contractor if not accurately describing events to date.

ANY AND ALL MINUTES FROM ANY PROGRESS MEETING ARE FOR INFORMATIONAL PURPOSES ONLY. THESE MINUTES ARE NOT INCORPORATED INTO THE CONTRACT DOCUMENTS AND ARE NOT LEGALLY BINDING UPON THE DEPARTMENT OR THE COUNTY.

(f) Form of Schedule Submittal.

All schedules including, but not limited to, the baseline schedule, the monthly progress schedules, and any required recovery schedules shall be submitted by the Contractor to the County in three (3) paper copies and one (1) copy on CD.

GP-8.05 LIMITATIONS OF OPERATION

The Contractor shall conduct the Work at all times in such a manner and in such sequence as will assure the least interference with the public.

Except as otherwise stated in the Contract Documents, no Work shall be done on Saturdays, Sundays, or Holidays without the prior written approval of the Engineer. Except for

emergencies, approval to Work on Saturdays, Sundays and Holidays shall be obtained forty-eight (48) hours in advance.

GP-8.06 CHARACTER OF WORKMEN, METHODS AND EQUIPMENT

(a) The Contractor shall employ sufficient labor and Equipment for prosecuting the several and all classes of Work to achieve Full and Final Completion in the manner and time required by the Contract.

Workmen must have sufficient skill and experience to properly perform the Work assigned to them. All workmen engaged in special Work or skilled Work shall have sufficient experience in such Work and in the operation of the Equipment required to perform the Work properly and satisfactorily.

(b) Any person employed by the Contractor or by any Subcontractor who, in the opinion of the Engineer, does not perform his Work in a proper manner or is intemperate or disorderly shall, at the written request of the Engineer, be removed forthwith by the Contractor or Subcontractor employing such person, and shall not be employed again in any portion of the Work without the prior written approval of the Engineer.

Should the Contractor fail to remove such person or persons as required in this GP-8.06(b), or fail to furnish suitable and sufficient personnel for the proper prosecution of the Work, the Engineer may withhold estimates and/or monies which are or may become due on the Contract until a satisfactory understanding and resolution is reached in the County's sole discretion.

(c) Only persons thoroughly trained and skilled in the task assigned them may be employed on any portion of the Work, or they shall be removed by the Contractor.

When County, State or federal laws require that certain persons (such as, by way of example, electricians, plumbers, etc.) be licensed, then all such persons employed on the Work shall be so licensed.

(d) The Contractor shall confine the operations of Contractor's employees and agents to the limits as provided by law, regulations, executive orders, ordinance, permits or directions of the Department. Generally, the "off-Road" area will be the same as the "limit of Contract" line.

(e) All workmanship shall be of good quality. Whenever the method or manner of the Work or manner of procedure is not specifically stated or shown in the Contract Documents, then it is intended and understood that the best standard practice shall be adhered to by the Contractor. Recommendations of the manufacturers of approved Materials shall be considered as a part of and incorporated into the Standard Specifications and all Materials shall be applied, installed, connected, erected, used, cleaned and conditioned as so called for thereby. This, however, does not remove any requirement in Contract to add to the manufacturer's recommendations.

All Materials shall be accurately assembled, set, etc., and when so required in good Construction, shall be true to line, even, square, plumb, level and regularly spaced, coursed, etc. Under no circumstances, either in new or old Work, shall any Material be applied over another which has not been thoroughly cleaned, sanded or otherwise treated so as not to impair the finish, adhesion, or efficiency of the next applied item.

(f) Equipment to be used on the Work shall meet the requirements of the Work and produce a satisfactory quality of Work in accordance with the Contract. The Engineer may order the removal and require replacement of any unsatisfactory Equipment at the Engineer's sole discretion. When the methods and Equipment to be used by the Contractor in accomplishing the Construction are not prescribed in the Contract, the Contractor is free to use any methods or Equipment that Contractor demonstrates in advance to the satisfaction and written approval of the Engineer will accomplish the Contract Work in conformity with the requirements of the Contract.

When the Contract specifies that the Construction be performed by the use of certain methods and Equipment, such methods and Equipment shall be used unless others are pre-authorized by the Engineer in writing. If the Contractor desires to use a method or type of Equipment other than those specified in the Contract, the Contractor shall request authority from the Engineer to do so. The request shall be in writing and shall include a full description of the methods and Equipment proposed for use and an explanation of the reasons for Contractor desiring to make the change. If written pre-approval of the Engineer is given, it will be on the condition that the Contractor will be fully responsible for producing Construction Work in conformity with Contract requirements. If, after trial use of the substituted methods or Equipment, the Engineer determines that the Work produced does not meet Contract requirements, the Contractor shall promptly discontinue the use of the substituted method or Equipment and shall complete the remaining Construction with the specified methods and Equipment in accordance with the Contract. The Contractor shall remove the deficient Work and replace it with Work of specified quality, or take such other corrective action as the Engineer may direct. Any Change Order issued, if any, in accordance with this GP-8.06(f) shall not result in an increase in Contract price or Contract Time.

(g) All methods, procedures and results are subject to the Engineer's approval as to the finished result to be obtained. However, this is not to be interpreted as placing upon the Engineer any responsibility for the Work management that is solely the responsibility of the Contractor.

The Contractor shall at all times enforce strict discipline and good order among Contractor's employees and agents. The Contractor shall neither employ any unfit person nor shall the Contractor permit an unfit person to remain on the Work site. The Contractor shall enforce all instructions relative to use of water, heat, power, smoking, and shall control any use of fires, as required by law, regulation, and the Contract and by the Department. Employees and agents of the Contractor shall not loiter on, near or about the Work site before or after work.

GP-8.07 SUSPENSION OF WORK

Revised
October 11, 2013

(a) The Engineer may unilaterally order the Contractor in writing to suspend the Work, wholly or in part, for such period or periods as Engineer may deem necessary, in the Engineer's sole discretion, for reasons including, but not limited to, unsuitable weather or such other conditions as are considered unfavorable for the proper prosecution of the Work, or for such time as is necessary because the Contractor has failed to carry out orders given or to perform any and all provisions of the Contract. If it should become necessary to stop Work for an indefinite period, the Contractor shall store all Materials in such manner that they will not obstruct or impede the traveling public unnecessarily or become damaged in any way, and the Contractor shall take every precaution to prevent damage or deterioration of the Work performed, provide suitable drainage by opening ditches, Shoulder drains, etc., and erect temporary Structures where necessary.

(b) If the performance of all or any part of the Work is for an unreasonable period of time, suspended, delayed, or interrupted by an act of the Engineer in the administration of this Contract, or by Engineer's failure to act within the time specified in this Contract (or if no time is specified, within a reasonable time), an adjustment shall be made for any increase in the cost of performance of this Contract (excluding profit) necessarily caused by an unreasonable suspension, delay, or interruption and a Contract Modification executed accordingly. However, no adjustment shall be made under this GP-8.07 for any suspension, delay, or interruption of the Work to the extent that performance would have been so suspended, delayed or interrupted by any other cause, including, but not limited to, the fault or negligence of the Contractor, including, but not limited to, GP-8.07(a) and (c), or for which an equitable adjustment is provided for or excluded under any other provisions of this Contract.

(c) The Engineer shall have the unilateral authority to suspend the Work, wholly or in part, due to the failure of the Contractor to correct conditions unsafe for the workers or the general public; for Contractor's failure to carry out the requirements of the Contract Documents; or as directed in conformance with the Contract Documents for conditions considered unsuitable for the prosecution of the Work.

(d) No claim under this General Provision shall be allowed:

(1) For any costs incurred more than twenty (20) Days before the Contractor shall have notified the Engineer in writing of the act or failure to act involved (but this requirement shall not apply as to a claim resulting from a suspension ordered by Engineer); and

(2) Unless the claim, in an amount stated, is asserted in writing as soon as practicable after the termination of a suspension, delay, or interruption, but not later than the date of final payment under the Contract.

(e) If the Contractor should neglect to prosecute the Work properly or fail to perform any provision of this Contract, the County after three (3) Days' Written Notice to the Contractor may, without prejudice to any other remedy, make good such deficiencies and/or perform the Contract or any portion thereof, as deemed applicable and appropriate by the County in its sole

discretion, and may deduct the cost thereof from the payment then or thereafter due the Contractor.

GP-8.08 TERMINATION FOR DEFAULT - DAMAGES FOR DELAY - TIME EXTENSIONS.

(a) If the Contractor refuses or fails to timely and properly prosecute the Work, in whole or in part, with such diligence as shall insure Full and Final Completion within the Contract Time, or breaches the terms of the Contract, termination for default, in whole or in part, shall be evidenced and the Department may, by Written Notice to the Contractor, terminate the Contract and the Contractor's right to proceed with the Work, in whole or in part, in accordance with this GP-8.08.

(b) The Department, upon proof that sufficient cause exists to satisfy such action, in the County's discretion, may without prejudice to any other right or remedy, terminate the Contract for default, in whole or in part. Termination for default, in whole or in part shall be evidenced and documented by Written Notice by the County to the Contractor and said termination for default shall be effective seven (7) days after Contractor's receipt of such Written Notice. Upon a termination for default the County may take over the Work and take possession of the Work and of all Materials, tools, Equipment and plant thereon and prosecute the same to completion, by contract, by whatever method may be deemed expedient, or otherwise, and may take possession of and utilize in completing the Work, the Materials, Equipment, and plant as may be on the site of the Work and necessary therefore. Whether or not the Contractor's right to proceed with the Work is terminated for default, the Contractor and its Sureties shall be liable for any damage to the County resulting from the Contractor's refusal or failure to achieve Full and Final Completion of the Work within the Contract Time and/or the Contractor's breach of the Contract Documents.

The County may appropriate or use any or all Materials and Equipment intended to be incorporated in the Contract as may be suitable and acceptable and may enter into an agreement for the completion of said Contract according to the terms and provisions thereof, or use such other methods as in the County's determination shall be required for the completion of said Contract in a manner acceptable to the County.

(c) Examples of sufficient cause to terminate for default include, but are not limited to, cases where the Contractor should:

- (1) Be adjudged a bankrupt or make a general assignment for the benefit of creditors,
- (2) Have a receiver appointed on account of insolvency,
- (3) Fail to or refuse to supply properly skilled persons or proper Materials, Equipment except in cases for which extension of time is provided by the County,

(4) Fail to make payment to a Subcontractor, materialmen, supplier, and/or other persons.

(5) Fail to comply with any law, regulation, executive order, ordinance, or persistently disregarded the instructions of the Engineer, or

(6) Breach any material representation, warranty, covenant, condition, obligation, or provision of the Contract.

(d) If the County terminates for default of the Contract under this GP-8.08, the Contractor shall not be entitled to receive any further payment until the Contract Work is finished and, even then, only if the unpaid balance of the Contract price shall exceed the expenses of finishing the Work, including compensation for additional managerial and administrative services, shall such excess be paid to the Contractor. If such expenses shall exceed such unpaid balance, the Contractor shall pay the difference to the County. The expenses incurred by the County as herein provided, and the damage incurred by the County as herein provided, and the damage incurred through the Contractor's default, shall be itemized by the Engineer and a certified copy supplied to the Contractor.

(e) The Contractor's right to proceed may not be terminated for default and the Contractor shall not be charged with resulting damages if:

(1) The delay in the completion of the Work arises solely from unforeseeable causes beyond the control and without the act, omission, fault or negligence of the Contractor including, but not restricted to, acts of God, acts of the public enemy, acts of the County in either its sovereign or contractual capacity, acts of another contractor in the performance of a contract with the County, fires, floods, epidemics, quarantine, restrictions, strikes, freight embargoes, unusually severe weather, or delays of Subcontractors or supplies arising solely from unforeseeable causes beyond the control and without the act, omission, fault or negligence of either the Contractor and/or the Subcontractors, suppliers or materialmen; and

(2) The Contractor, within ten (10) Days from the beginning of any such delay (unless the Engineer grants a further period of time before the date of final payment under the Contract), notifies the Engineer in writing of the causes of delay. The Engineer shall ascertain the facts and the extent of the delay and extend the Contract Time for completing the Work when, in the Engineer's judgment, the findings of fact justify such an extension, and the Engineer's findings of fact shall be final and conclusive on the parties, subject only to appeal as provided in the GP-5.15 "Disputes".

(f) If, after notice of termination for default of the Contract and the Contractor's right to proceed under these General Provisions, it is determined for any reason that the Contractor was not in default under the provisions of the Contract, or that the delay was excusable under the provisions of the Contract, the rights and obligations of the parties shall be the same as if the notice of termination had been issued pursuant to GP-8.10.

(g) The rights and remedies of the County provided in this GP 8.08 are in addition to any other rights and remedies provided by law, equity and/or under this Contract.

(h) As used in GP 8-08, the term Subcontractors, materialmen, or suppliers means Subcontractors, materialmen or suppliers at any tier.

GP-8.09 LIQUIDATED DAMAGES

TIME IS AN ESSENTIAL ELEMENT OF THE CONTRACT AND IT IS IMPORTANT THAT THE WORK BE VIGOROUSLY PROSECUTED UNTIL FULL AND FINAL COMPLETION OF THE CONTRACT.

FOR EACH DAY THAT FULL AND FINAL COMPLETION REMAINS UNACHIEVED BEYOND THE CONTRACT TIME, THE CONTRACTOR AND/OR ITS SURETY SHALL BE LIABLE FOR LIQUIDATED DAMAGES IN THE AMOUNT PROVIDED FOR IN THE CONTRACT.

(a) ALL ADDITIONAL COSTS AND CHARGES INCURRED BY THE COUNTY, INCLUDING, BUT NOT LIMITED TO, ANY AND ALL DAMAGE TO PERSONS OR PROPERTY, THE COST OF COMPLETING THE WORK UNDER THE CONTRACT, SHALL BE DEDUCTED FROM ANY MONIES DUE OR WHICH MAY BECOME DUE TO CONTRACTOR. IF THE EXPENSE SO INCURRED BY THE COUNTY IS LESS THAN THE SUM WHICH WOULD HAVE BEEN PAYABLE UNDER THE CONTRACT IF IT HAD BEEN COMPLETED BY SAID CONTRACTOR, THE SAID CONTRACTOR SHALL BE ENTITLED TO RECEIVE THE DIFFERENCE, AND IF SUCH EXPENSE EXCEEDS THE SUM WHICH WOULD HAVE BEEN PAYABLE UNDER THE CONTRACT, THE CONTRACTOR AND THE SURETY SHALL BE LIABLE AND SHALL PAY TO THE COUNTY THE AMOUNT OF SAID EXCESS.

(b) IF FIXED AND AGREED LIQUIDATED DAMAGES ARE PROVIDED IN THE CONTRACT AND IF THE COUNTY SO TERMINATES THE CONTRACT, AND ACCORDINGLY THE CONTRACTOR'S RIGHT TO PROCEED, THE RESULTING DAMAGE SHALL CONSIST OF SUCH LIQUIDATED DAMAGES FOR THE REASONABLE TIME REQUIRED FOR FULL AND FINAL COMPLETION OF THE WORK TOGETHER WITH ANY INCREASED COSTS AND EXPENSES INCURRED BY THE COUNTY IN COMPLETING THE WORK.

(c) IF FIXED AND AGREED LIQUIDATED DAMAGES ARE PROVIDED IN THE CONTRACT AND IF THE COUNTY DOES NOT SO TERMINATE THE CONTRACTOR'S RIGHT TO PROCEED, THE RESULTING DAMAGE SHALL CONSIST OF THESE LIQUIDATED DAMAGES UNTIL FULL AND FINAL COMPLETION IS ACHIEVED.

(d) Interest shall accrue upon all damages, liquidated or otherwise, at the statutory rate of interest provided pursuant to the Maryland Constitution and the Maryland Code, as applicable and as amended.

GP-8.10 TERMINATION FOR CONVENIENCE OF THE COUNTY

(a) The performance of Work under this Contract may be terminated for convenience by the County, in whole, or in part, whenever the Engineer shall determine that such termination for convenience is in the best interest of the County. Any such termination for convenience shall be effected by Engineer's delivery to the Contractor of a Written Notice of termination for convenience specifying the extent to which performance of Work under the Contract is terminated, and the date upon which such termination becomes effective.

(b) After receipt of notice of termination for convenience, and except as otherwise directed by the Engineer, the Contractor shall:

(1) Stop Work under the Contract on the date and to the extent specified in the Written Notice of termination for convenience;

(2) Place no further orders or Subcontracts for Materials, supplies, Equipment, services or facilities, except as may be necessary for completion of the portion of the Work under the Contract that is not terminated for convenience;

(3) Terminate all orders and Subcontracts to the extent that they relate to the performance of Work terminated by notice of termination for convenience;

(4) Assign to the County in the manner, at the times, and to the extent directed by the Engineer, all of the right, title, and interest of the Contractor under the orders and Subcontracts, in which case the County shall have the right, in its discretion, to settle or pay any or all claims arising out of such orders and Subcontracts, or assume said orders and subcontracts, or do otherwise, as deemed appropriate in the sole discretion of the County;

(5) Settle all outstanding liabilities and all claims arising out of the termination of orders and Subcontracts, with the approval or ratification of the Engineer, to the extent he may require, which approval or ratification shall be final for all the purposes of this GP-8.10;

(6) Transfer title and deliver to the County, in the manner, at the times and to the extent, if any, directed by the Engineer, (a) the fabricated or unfabricated parts, Work in process, completed Work, supplies, and other Material produced as a part of, or acquired in connection with the performance of the Work terminated for convenience by the Written Notice of termination for convenience, and (b) as applicable, the completed or partially completed Plans, Contract Drawings, As-Built Drawings, operation and maintenance manuals, warranty certificates, information, and other property which, if the Contract had been completed, would have been required to be furnished to the County;

(7) Use its best effort to sell, in the manner, at the times, to the extent, and at the price or prices directed or authorized by the Engineer, any property of the types referred to in (6) above; provided, however, that the Contractor (a) may not be required to extend credit to any

purchaser, and (b) may acquire any such property under the conditions prescribed by and at a price or prices approved by the Engineer; and provided further that the proceeds of any such transfer or disposition shall be applied in reduction of any payments to be made by the County to the Contractor under this Contract or shall otherwise be credited to the price or cost of the Work covered by this Contract or paid in such other manner as the Engineer may direct;

(8) Complete performance of such part of the Work as may not have been terminated by the Written Notice of termination for convenience; and

(9) Take any action that may be necessary, or as the Engineer may direct, for the protection and preservation of the property related to this Contract which is in the possession of the Contractor and in which the County has or may acquire an interest. The Contractor shall submit to the Engineer a list, with Certification as to quantity and quality, of any or all items of inventory not previously disposed of, exclusive of items the disposition of which has been directed or authorized by the Engineer, and may request the County to remove such items or enter into a storage agreement covering them. Not later than fifteen (15) Days thereafter, the County shall accept title to such items and remove them or enter into a storage agreement covering the same; provided, that the list submitted shall be subject to verification by the Engineer upon removal of the items, or if the items are stored, within forty-five (45) Days from the date of submission of the list, and any necessary adjustment to correct the list as submitted shall be made prior to final settlement.

(c) After receipt of a Written Notice of termination for convenience, the Contractor shall submit to the Engineer his termination for convenience claim, in the written form and with Certification prescribed by the Engineer. This claim shall be submitted promptly in accordance with GP-5.14 and GP-5.15 of these Standard Specifications, unless an extension is granted in writing by the Engineer, upon timely request of the Contractor in writing.

(d) Subject to this GP-8.10 (c), the Contractor and the Engineer may agree upon the whole or any part of the amount or amounts to be paid to the Contractor by reason of the total or partial termination for convenience of Work pursuant to this GP 8-10, which amount or amounts may include a reasonable allowance for profit on Work done; provided, that such agreed amount or amounts, exclusive of settlement costs, shall not exceed the total Contract price as reduced by the amount of payments otherwise made and as further reduced by the Contract price of Work not terminated for convenience. If the parties so agree, the Contract shall be amended with a Contract Modification, and the Contractor shall be paid the amount specified therein.

(e) In the event of the failure of the Contractor and the Engineer to agree as provided in GP-8.10 (d), upon any amount to be paid to the Contractor by reason of the termination for convenience of Work pursuant to this General Provision, the Engineer shall pay to the Contractor the amounts determined by the Engineer as follows, but without duplication of any amounts agreed upon in accordance with GP-8.10 (d):

(1) For completed supplies or services accepted by the County (or sold or acquired as provided in GP-8.10 (b)(7) above) and for which payment has not theretofore been made, a sum equivalent to the aggregate price for the supplies or services computed in accordance with the

price or prices specified in the Contract, appropriately adjusted for any saving of freight or other charges;

(2) The total of:

(a) The costs incurred in the performance of the Work terminated for convenience, including initial costs and preparatory expense allocable thereto, but exclusive of any costs attributable to supplies or services paid or to be paid for under GP-8.10 (e)(1) hereof; and

(b) The cost of settling and paying claims arising out of the termination of Work under Subcontracts or orders, as provided in GP-8.10 (b)(5) above, which are properly chargeable to the termination for convenience portion of the Contract (exclusive of amounts paid or payable on account of supplies or Materials delivered or services furnished by Subcontractors or vendors before the effective date of the Written Notice of termination for convenience, which amounts shall be included in the costs payable under GP-8.10 (e)(2)(a); and

(c) A sum, as profit on GP-8.10 (e)(2)(a), determined by the Engineer to be fair and reasonable; provided, however, that if it appears that the Contractor would have sustained a loss on the entire Contract had it been completed, no profit shall be included or allowed under this GP-8.10 (e)(2)(c) and an appropriate adjustment shall be made reducing the amount of the settlement to reflect the indicated rate of loss; and

(d) The reasonable cost of settlement accounting, legal, clerical, and other expenses reasonably necessary for the preparation of settlement claims and supporting data with respect to the terminated portion of the Contract and for the termination and settlement of Subcontracts thereunder, together with reasonable storage, transportation, and other costs incurred in connection with the protection or disposition of property allocable to this Contract.

The total sum to be paid to the Contractor under this GP-8.10 (e) shall not exceed the total Contract price as reduced by the amount of payments otherwise made and as further reduced by any Contract price of Work not terminated for convenience. Except for normal spoilage, and except to the extent that the County shall have otherwise expressly assumed the risk of loss, there shall be excluded from the amounts payable to the Contractor as provided in GP-8.10 (e), the fair value, as determined by the Engineer, of property that is destroyed, lost, stolen, or damaged so as to become undeliverable to the County or to a buyer pursuant to GP-8.10 (b)(7).

(f) The Contractor shall have the right of appeal, under GP-5.15 "Disputes", from any determination made by the Engineer under this GP-8.10, except that if the Contractor has failed to timely submit its claim within the time provided in this GP-8.10, and has failed to request extension of such time, Contractor shall have no such right of appeal. In any case where the Engineer has made a determination of the amount due under this GP-8.10, the County shall pay to the Contractor the following:

(1) If there is no right of appeal hereunder and/or if no timely appeal has been taken, the amount so determined by the Engineer; or,

- (2) If an appeal has been taken, the amount finally determined on such appeal.
- (g) In arriving at the amount due the Contractor under this GP-8.10 there shall be deducted:
- (1) All unliquidated advance or other payments or account theretofore made to the Contractor, applicable to the terminated for convenience portion of this Contract;
- (2) Any claim which the County may have against the Contractor in connection with this Contract; and
- (3) The agreed price for, or the proceeds of sale of, any Materials, supplies, or other things acquired by the Contractor or sold, pursuant to the provisions of this GP-8.10, and not otherwise recovered by or credited to the County.
- (h) If the termination for convenience hereunder be partial, the Contractor may file with the Engineer a written claim for an equitable adjustment in accordance with GP-5.14 and GP-5.15 of the price or prices specified in the Contract relating to the continued portion of the Contract (the portion not terminated by the Written Notice of termination for convenience), and such equitable adjustment as may be agreed upon shall be made in such price or prices in a Contract Modification.
- (i) The County may, from time to time, under such terms and conditions as it may prescribe, make partial payments and payments on account against costs incurred by the Contractor in connection with the terminated for convenience portion of this Contract whenever, in the opinion of the Engineer, the aggregate of such payments shall be within the amount to which the Contractor shall be entitled hereunder. If the total of such payments is in excess of the amount finally agreed or determined to be due under this General Provision 8.10, such excess shall be payable by the Contractor to the County upon demand, together with interest at the legal rate as prescribed by State law for the period from the date such excess payment is received by the Contractor to the date on which the excess is repaid to the County.
- (j) Unless otherwise provided for in this Contract, or by applicable statute, the Contractor shall, from the effective date of termination for convenience until the expiration of three (3) years after final settlement under this Contract, preserve and make available to the County at all reasonable times at the office of the Contractor but without direct charge to the County, all Contractor's books, records, documents and other evidence bearing on the costs and expenses of the Contractor under this Contract and relating to the Work terminated for convenience hereunder, or, to the extent approved by the Engineer, photographs, microphotographs, or other authentic reproductions thereof. If the Contract involves the use of federal or State funds, Contractor shall retain records and documentation as required by GP-7.36.

GP-8.11 SUCCESSFUL TERMINATION OF CONTRACTOR'S RESPONSIBILITY

Full and Final Completion is the date upon which the County acknowledges in writing that the Contractor fully and finally completed all aspects of the Contract and the Contract Work, and met all terms, conditions and obligations of the Contract, as further described herein. Full and Final Completion of a Contract includes Final Acceptance for Maintenance of all Contract Work; the authorization of final payment by the County; the Contractor's and its Surety's compliance with all obligations under the Contract; the submission of all Plans, Contract Drawings, As-Built Drawings (as described below), operation and maintenance manuals, and warranty certificates; the completion of all punch list Work; and final payment by the County to the Contractor.

The Contractor shall, as the Work progresses, neatly record on a set of final signed and sealed As-Built Drawings the Work as actually constructed by the Contractor and reflecting all Working Drawings including, but not limited to, any changes and all revisions to the Work made during the course of the Contract wherever it differs from the Contract Documents. Upon Final Acceptance for Maintenance of the Work, the Contractor shall turn over the As-Built Drawings to the County. No Full and Final Completion of the Contract by the County may occur until these As-Built Drawings are submitted to and approved by the County.

GP-SECTION 9 PAYMENT

GP-9.01 SCOPE OF PAYMENT

(a) Payments to the Contractor will be made for the actual quantities of Contract Items performed in accordance with the Plans and Contract Documents and if, upon completion of the Construction and the Work, these actual quantities show either an increase or decrease from the quantities given in any Contract schedule, the Contract unit prices will still prevail, except as provided in GP-4.04 "Variations in Estimated Quantities", or in a Contract Modification.

(b) Except as may otherwise be provided herein, the Contractor shall accept the compensation as provided by the Engineer under this GP-Section 9:

(1) In full payment for furnishing all Materials, lab, tools, and Equipment and any incidentals necessary to the completed Work and for performing all Work contemplated and embraced under the Contract;

(2) For all loss or damage arising from the nature of the Work, or from the action of the elements, or from any other unforeseen difficulties which may be encountered during the prosecution of the Work until Full and Final Completion of the Contract;

(3) For all risks of every description connected with the prosecution of the Work; and

(4) For all expenses incurred in consequence of suspension of the Work, if any, as herein authorized by the County.

(c) Where provisions in the Contract Documents relating to any unit price for a Contract Item require that the said unit price cover, and be considered, compensation for certain Work or Material essential to that Contract Item, this same Work or Material shall not also be measured or paid for under any other Contract Item which may appear elsewhere in the Contract Documents.

(d) The payment of any partial estimate or of any retained percentage by the County, in no way shall affect the obligation of the Contractor to Repair or renew any defective parts of the Construction and/or Work or to be responsible for all damages due to such defects.

(e) Payment to the Contractor under this section for Materials on hand in no way will be construed as acceptance by the Administration of title to the Material. Title shall remain with the Contractor until Final Acceptance for Maintenance of the Contract Work in accordance with GP-5.13.

The Contractor shall indicate its federal tax identification or social security number on the face of each invoice billed to the County.

(f) If the Contract is in excess of twenty-five thousand dollars (\$25,000), the Contractor and any Subcontractor with a lower tier Subcontract, in accepting each Contract payment from the County is making a Certification and representing and warranting to the County, prior to receiving a progress or final payment under this Contract, that the Contractor or Subcontractor has made payment from proceeds of prior payments, and that the Contractor or Subcontractor will make timely payments, from the proceeds of the progress or final payment then due it, to its Subcontractors, materialmen, and suppliers in accordance with Contractor or Subcontractor contractual arrangements with them and pursuant to State Finance and Procurement Article of the Maryland Annotated Code, as amended. This Certification may be required by the Engineer even if the Contract is for twenty-five thousand dollars (\$25,000) or less.

If the Contract is in excess of twenty-five thousand dollars (\$25,000), the Contractor further represents and warrants that it shall also obtain from each Subcontractor a Certification that payment from proceeds of prior payments have been made to any lower tier Subcontractors and that timely payments will be made to the lower tier Subcontractors and suppliers in conformance with contractual arrangements with those lower tier Persons. This Certification is not required from Subcontractors who have no lower tier Subcontracts. These Certifications may be required by the Engineer for contract of twenty-five thousand dollars (\$25,000) or less.

(g) For all Contract Items of Work, other than those to be paid by lump sum, after Final Acceptance for Maintenance of the Work and before final payment is made, the Engineer will make final measurements to determine the quantities of various Contract Items of Work performed as the basis for final settlement. The Contractor in case of unit price Contract Items will be paid for the actual amount of Work performed and for the actual amount of Materials in place, in conformance with the Contract Documents as shown by the final measurements made by the Engineer. All Work completed under the Contract will be measured by the Engineer in conformance with the standards of weights and measures recognized by the NBS and NIST.

The term lump sum when used as a Contact Item will mean complete payment for the unit of Work described and will be construed to include all necessary fittings and accessories for that Contract Item of Work.

(1) All longitudinal measurements for area will be made along the actual surface and not horizontally, and no deductions will be made for individual fixtures in the pavement having an area of nine (9) square feet or less. For all transverse measurements for area of Base Course and pavements, the dimensions to be used in calculating the pay area will be the neat dimensions shown on the Plans or as ordered in writing by the Engineer.

(2) Structure measurements will conform to the neat lines shown on the Plans or as ordered in writing by the Engineer, unless otherwise provided for elsewhere in the Contract Documents.

(3) Volumes of excavation, tamped fill and borrow pits will be calculated per cubic yard from the cross section and the use of average end area formulas. Volumes of other Work including, but not limited to, masonry and removal of masonry will be calculated by using arithmetical formulas. Where the volume is bounded by varying dimensions and there are no simple volumetric formulas applicable, frequent cross sections will be taken and the cubic yard volume computed from average end area formulas.

(4) Cement will be measured by weight.

(5) All items which are measured by the linear foot, including, but not limited to, pipe culverts, traffic barriers, underdrains, will be measured parallel to the base or foundation upon which such Structures are placed unless otherwise specified in the Contract Documents.

(6) The term gauge when used in connection with the measurement of uncoated steel sheet and light plates shall mean the USSG, except that when reference is made to the measurements of galvanized or aluminum sheets used in the manufacture of corrugated metal pipe, metal plate pipe culverts and arches, and metal cribbing, the term gauge shall mean that specified in M 36, M 167, M 196 or M 197.

(7) When the term gauge refers to the measurement of wire, it shall mean the Washburn & Moen wire gauge as referenced in the New Departure Handbook. A tolerance of plus or minus 0.003 inch shall apply.

(8) The term ton shall mean the short ton consisting of two thousand (2,000) pounds avoirdupois. All Materials which are specified for measurement by the ton shall be weighed on accurate, approved scales conforming to the requirements of the NBS Handbook 44. A digital recorder and printout shall be required on all truck scales. The digital recorder shall produce a printed record of the gross, tare, net weights, the time, date, truck identification and Contract Number. Provisions shall be made so that the scales may not be manually manipulated during the printing process. The system shall be interlocked to allow printing only when the scale has come to rest.

(9) Except for computer operated scales, all weights shall be certified by a bonded weigh Person supplied by the Contractor, producer or supplier. The security bond shall be one hundred thousand dollars (\$100,000.00).

(10) If the Material is shipped by rail, the car weight may be accepted but the payment will be limited to the actual weight of Material. Car weights will not be acceptable for Material to be passed through mixing plants.

(11) All Materials for which measurements are obtained by the cubic yard shall be hauled in approved vehicles and measured at the point of delivery. No allowance will be made for the settlement of Material in transit. Approved vehicles for this purpose shall be of any size or type acceptable to the Engineer, provided that the body is of such shape that the actual contents may be readily and accurately determined. Unless all approved vehicles are of uniform capacity, each approved vehicle must bear a plainly legible identification mark indicating the specific approved capacity. All vehicles shall be loaded to at least their water level capacity, and all loads shall be leveled when the vehicles arrive at the point of delivery.

(12) When requested by the Contractor and approved by the Engineer in writing, Material specified to be measured by the cubic yard may be weighed, and such weights will be converted to cubic yards for payment purposes. Factors for conversion from weight measurement to volume measurement will be determined by a qualified laboratory and shall be agreed to by the Contractor before such method of measurement of pay quantities will be approved by the Engineer.

(13) Liquid asphalt Material delivered for the project will be measured by volume in each railroad tank car, tank truck, distributor tank or drums in which it is delivered. The measurements will be taken when the asphalt Material is of a uniform temperature and free from air bubbles, and the temperature of the Material will be recorded at that time by the Contractor.

The volumetric measurement of the asphalt material will be based upon a temperature of sixty degrees Fahrenheit (60° F). Only the quantity of asphalt Material actually placed in the Work and accepted will be considered in determining the amount due the Contractor.

Reference is hereby made to D 1250, Petroleum Measurement Tables.

(14) Timber will be measured by the thousand feet board measure (MBM) actually incorporated in the structure. Measurement will be based on nominal widths and thicknesses and the extreme length of each piece.

(15) Rental of Equipment will be measured in hours of actual Work time by the Contractor, moving-in and moving-out costs, if any, and necessary traveling time of the Equipment within the limits of the Contract, except when special conditions make some other method of measurement desirable as determined by the Engineer.

(h) Payment will not be allowed for stored Materials except in specific instances approved in writing by the Engineer involving specially manufactured Contract Items or Contract Items

requiring a long lead time for delivery and as further described in GP-9.01(i), (j) and (k). No payment for stored Material will be made if it is anticipated that the Material will be incorporated into the Work within thirty (30) Days of the delivery of said Material to the Contractor or Work site.

(i) When the Contractor requests payment allowance for stored Materials and the Engineer gives written approval of those Materials stored, the following terms and conditions shall apply:

(1) For Superstructure members delivered and stored on the Work site, an allowance of one hundred percent (100%) of the Material cost plus freight charges as invoiced may be made provided the cost does not exceed ninety percent (90%) of the Contract price of the applicable Contract Item. The allowance will be based upon validated invoices or bills for Material including freight charges, and a copy thereof shall be made a part of the documented records for the Contract.

(2) For reinforcement steel, piling, pipe, traffic barrier, signs and sign assemblies, and other nonperishable Material in storage on the Contract, but excluding aggregates, cement, seed, plants, fertilizer or other perishable Contract Items, an allowance of one hundred percent (100%) of the invoiced cost of the Material plus freight charges to the Contractor may be made provided the cost does not exceed ninety percent (90%) of the Contract price of the applicable Contract Item. Such Material shall be delivered and stockpiled at the Contract Work site, and shall be tested by the Administration and found to conform with the Contract Documents or have been accepted under a County-approved Certification program prior to the allowance.

(3) No payment allowance will be made for fuels, form lumber, falsework, temporary Structures or other Materials of any kind which will not become an integral part of the finished Work.

(4) Only end product manufactured Material or fully fabricated products that are awaiting installation or incorporation into the finished Work are eligible for prepayment. Components, elements, or ingredients of a finished product are not eligible for prepayment or payment allowance.

(5) Stored Material for which a payment allowance is requested shall be stored in an approved manner in areas within the County where damage is not likely to occur. If any of the stored Materials are lost or become damaged in any manner, the Contractor shall be responsible for Repairing or replacing the damaged Materials. The value of the lost or damaged Material will be deducted from the Contractor's subsequent estimates until replacement has been accomplished. The request for payments allowances for any Materials stored on private property within the County shall be accompanied by a release from the applicable owner and/or tenant of such property agreeing to permit the removal of the Materials from the property without cost to the County.

When it is considered impractical to store Materials on the Work site, the Engineer may approve storage areas in the vicinity of the Work site which will be considered as the Work site for purposes of those stored Materials.

When storage of the Materials within the County is not practical, written approval shall be obtained from the Engineer for storage elsewhere. Storage of Materials outside the County will be subject to the conditions set forth in this GP-9.01 and limited to Materials exceeding twenty-five thousand dollars (\$25,000), which are designed and fabricated exclusively for use on the Contract.

(6) Stored Material for which payment has been made, either wholly or partially by the County, shall not be removed from the approved location or Work site until such time that it is to be incorporated into the Work, unless authorized by the Engineer in writing.

(j) The following items shall accompany any written request by the Contractor for payment allowance for stored Materials:

(1) Consent of the Contractor's Surety specifying the Material type and the Contract Item(s) in which the Material is to be used.

(2) Validated invoices with the signature of an officer of the company supplying the Material showing actual cost.

(3) A notarized statement from the Contractor attesting that the invoices as submitted from the supplier do not include charges or fees for placing, handling, erecting or any other charges or markups other than the actual Material cost, sales tax(es), if applicable, and freight charges.

(4) Bills of lading showing delivery of the Material.

(5) The request for allowances for any Materials stored on property outside the County shall be accompanied by a release from the owner or tenant of such property agreeing to permit verification by the Department's Division of Construction Contracts Administration that the Material is stored at the approved location, and to permit the removal of the Materials from the property without cost to the County.

(6) Inspection test reports, Certifications and/or a written statement from the Department's Division of Construction Contracts Administration attesting to the inspection and approval of the Material.

Upon receipt of the above by the Engineer and verification by the Department's Division of Construction Contracts Administration that the Material is stored at the approved location, the Engineer will authorize payment.

The Contractor shall pay the Material supplier the amount shown on the invoice within seven (7) Calendar Days of receipt of payment from the Administration. Failure to make invoice payments as specified will be cause for the County to deduct the monies from future estimates to the Contractor.

Copies of all pertinent data relating to any stored Materials shall be made by the Contractor and distributed to the Department's Division of Construction Contracts Administration for retention as part of the documented records for the Contract.

(k) The Engineer may withhold, or on account of subsequently discovered evidence, nullify the whole or a part of any payment for stored Materials to such extent as may be necessary to protect the County from loss on account of:

(1) Defective Work not remedied.

(2) Claims filed, or reasonable evidence indicating probable filing of claims, by parties other than the Contractor.

(3) Failure of the Contractor to make payments properly to Subcontractors or for material or labor.

(4) A reasonable doubt that Full and Final Completion of the Contract can be achieved for the balance then unpaid.

(5) Damage to another contractor.

(6) Failure of the Contractor to submit data required within the time limits stated in the Contract Documents.

Upon removal of the Engineer's hold and resolution of all related issues, payment shall be made for any amounts withheld.

GP-9.02 FORCE ACCOUNT WORK

When the Contractor is required to perform Extra Work as a result of a Change Order or Contract Modification to the Contract for which there are no applicable unit prices in the Contract, the Engineer and the Contractor shall make every effort to come to an agreed price for the performance of such Extra Work. If an agreement cannot be reached by the parties prior to the time that Extra Work must commence, the Engineer may, in writing, order the Extra Work done on a force account basis by the Contractor, to be compensated in accordance with the following:

(a) **Labor.** For all labor and for foremen in direct charge of the specific operations of the Work, the Contractor shall receive the rate of wage agreed upon in writing by the County and the Contractor in either the Contract or a Contract Modification before the Contractor begins such Extra Work for each and every hour that said labor and foremen are actually engaged in such Extra Work, to which cost shall be added an amount equal to the percentage of the sum shown below. No additional allowance will be considered for Contract Bond, insurance, taxes or other fringe benefits, except as permitted in the County's discretion in a Written Notice or a Contract Modification. The number of laborers and foremen engaged in the Extra Work will be subject to

regulation by the Engineer and shall not exceed the number the Engineer deems most practical and economical for the Extra Work. The Contractor shall submit certified payrolls in conformance with the Contract Documents and pursuant to GP-9.02(g) signed by a legally authorized officer of the Contractor. Superintendent's time will not be allowed.

Highway Contracts65%
Utility Contracts.....75%
Building Contracts65%

(b) Materials. For Materials accepted by the Engineer and used for the Extra Work, the Contractor shall receive the actual cost of such Materials delivered to the Work site. This cost includes transportation charges paid by Contractor (exclusive of machinery rentals as specified in GP-9.02(d)), to which cost shall be added an amount equal to twenty percent (20%) plus prevailing State sales tax.

To substantiate Materials and transportation cost, original receipted invoices shall be submitted to the County by the Contractor, as further specified in GP-9.02(g).

If the Materials used in the force account Extra Work are not specifically purchased for the Extra Work but are taken from the Contractor's stock, then in lieu of the original invoices, the statements shall contain or be accompanied by an affidavit and Certification from the Contractor that shall certify that the Materials were taken from the Contractor's stock, that the quantity claimed was actually used, and that the price and transportation cost of the Material as claimed represents the actual cost.

The Administration reserves the right to furnish Materials as it deems appropriate, and the Contractor shall have no claim for any costs, overhead, or profit on these Materials.

(c) Subcontractor's Works.

(1) When a Contract Item of Extra Work is performed on a force account basis by a Subcontractor who is approved for this Extra Work by the Engineer, as may be required under GP-8.01, an amount equal to ten percent (10%) of the total cost shall be added to the final payment under GP-9.04 for such force account Extra Work and such amount of compensation shall be full and final compensation to the Contractor for the administration of the Extra Work performed by the Subcontractor under the force account basis.

(2) This additional ten percent (10%) compensation to the Contractor for administration shall only be allowed if the Extra Work requires particular trades or specialty work for which the Contractor is not prequalified, and not for Extra Work assigned to a Subcontractor for the convenience of the Contractor.

(d) Equipment. For any machinery or special Equipment approved by the Engineer for use on Extra Work (expressly excepting all small tools), including fuel and lubricants, the Contractor shall receive the rental rates and operating costs agreed upon in writing by the County and the Contractor in either the Contract or a Contract Modification before such Extra Work is begun by the Contractor for the actual time such Equipment is authorized on the Extra Work.

(1) Rental rate shall be based on the weekly rate converted into hours. To compute hourly rate use forty (40) hours per week.

(2) The rental rates and operating costs, including fuel and lubricant but excluding operators, for Extra Work shall be the current rates from the "Rental Rate Blue Book for Construction Equipment," published by the Equipment Guide Book Company and/or the "Rental Rate Blue Book for Older Construction Equipment." Both rental rate and operating rate will be subject to area adjustment per the "Rental Rate Blue Book for Construction Equipment." No other allowances or additions will be paid to the Contractor by the County.

(3) In the Engineer's discretion, rental rates will be applied to both idle time and actual operating time authorized by the Engineer, and operating rates will be applied to operating time only. Or, if the Engineer determines it to be in the County's best interest, standby rates shall apply when a piece of Equipment is required to remain on the Work site on standby status as authorized by the Engineer. For purposes of standby rates, when a unit of Equipment works for a portion of a day and is on standby for a portion, the total time allowed for rental rates shall not exceed eight (8) hours for that day and will be allowed for Working Days only. Standby rates shall be half of the normal hourly base rental rates without the operating expenses.

(4) Transportation costs of the Equipment directly attributable to force account Extra Work will be allowed. When it is necessary to obtain Equipment exclusively for force account Extra Work from sources beyond the Contract limits, the cost of transferring the Equipment to the Work site and return, including the use of any hauling unit, will only be allowed as an additional expense if the Contractor receives prior written approval from the Engineer.

(e) Superintendence/Use of Small Tools. No additional allowance shall be made for general superintendence, the use of small tools, or other costs for which no specific allowance is herein provided. For the purpose of definition under this GP-9.02, Equipment with a new cost of one thousand dollars (\$1,000) or less will be considered small tools.

(f) Compensation. The compensation provided for in this GP-9.02 shall be received by the Contractor as full and final payment, including, but not limited to, overhead and profit, for Extra Work, Change Order Work, and/or Contract Modification Work done on a force account basis. The Contractor may request partial payment for force account Extra Work prior to submitting final documentation under GP-9.02(g). Partial payment will be limited to fifty percent (50%) of the amount for the Extra Work fully and finally accomplished until all documentation has been received and approved by the County. The final force account payment request from the Contractor for any Extra Work will be subject to audit as specified in GP-7.36 "Retention of Records".

At the end of each applicable Day, the Contractor and the Engineer shall compare records of the cost of all Extra Work as ordered on a force account basis and mutually agree on a final record of the costs of Extra Work for that Day. This record must be signed by both the Engineer and the Contractor on a daily basis. Daily force account records for Extra Work performed and signed by a Subcontractor, must also be signed by the Contractor and the Engineer. Each party shall

retain a copy of these records as substantiation of all labor, Equipment, and Materials used by the Contractor and any of its Subcontractors in the performance of the force account Extra Work.

(g) Statements. No payment will be made by the County for Extra Work performed on a force account basis until the Contractor furnishes the Engineer with duplicate itemized statements of the cost of such force account Extra Work detailed as to the following:

(1) Name, classification, date, daily hours, total hours, rate, and extension for such laborer, or foreman.

(2) Designation, dates, daily hours, total hours, rental rate, and extension for each unit of machinery and Equipment.

(3) Quantities of Materials, prices and extensions.

(4) Transportation of Materials.

(5) Payments of items under this GP-9.02(g)(1) shall be accomplished by copies of certified payrolls. Under this GP-9.02(g)(2), original receipted invoices for rentals must be provided. GP-9.02(g)(3) and GP-9.02(g)(4) shall be accompanied by original receipted invoices for Materials used and related transportation charges. Any request for payment for force account Extra Work shall be submitted by the Contractor in strict compliance with this Section GP-9.02.

GP-9.03 PROGRESS PAYMENTS

(a) Current Estimates.

(1) **Lump Sum Contracts.** If requested by the Administration, the Contractor shall furnish an acceptable breakdown of the lump sum Contract price showing the amount included therein for each Pay Item of the Work. Said breakdown shall be in such detail so as to provide a basis for estimating monthly progress payments in connection with the Contract.

(2) **Monthly Estimates.** Except as otherwise stated in the Contract, each month the Administration will pay the Contractor for the Contract Work satisfactorily performed during the preceding calendar month, including Extra Work less five percent (5%). The five percent (5%) of the total Contract value retained by the Administration will not be released until final payment pursuant to GP-9.04 (unless partially released in a semi-final payment in the County's sole discretion). Current estimates will be based upon the Engineer's estimate of quantity (including Materials and/or Equipment complete in place) satisfactorily performed. In the instance of lump sum Contract Items, the Engineer's estimate shall be the proper fraction of the lump sum Contract Items satisfactorily performed during the preceding month. All quantities, estimates and fractions will be reasonably accurate approximations and are subject to correction (a) in subsequent current estimates, (b) in any semi-final estimate and, (c) in final payment. Any and/or all partial payments or monthly payments may be withheld in the event current requirements of the Contract Documents have not been complied with by the Contractor. Should

either the Engineer or the Contractor be of the opinion that any estimates, quantities and/or fractions (either as to an individual current estimate or accumulations thereof) do not represent a reasonably accurate approximation of actual Work satisfactorily performed, then details questioned shall be reviewed by the Engineer and then any corrections adjusted by the Engineer for in the next current estimate.

Deferred Monthly Payment. Should the amount(s) due the Contractor for any one month be less than five hundred dollars (\$500.00), payment will be deferred until such time as the amount(s) due the Contractor under subsequent estimates, combined with that month for which the amount(s) due was less than five hundred dollars (\$500.00), shall equal five hundred dollars (\$500.00) or more.

(b) Semi-Final Estimate Payments and Partial Semi-Final Estimate Payments.

(1) Semi-Final Estimate Payments. Upon Final Acceptance for Maintenance by the Administration of the Contract Work, pursuant to GP-5.13(b), the Administration, at the Contractor's request and with consent of the Contractor's Surety, will pay the Contractor, within forty-five (45) Calendar Days of said request, what is hereby known as a semi-final estimate payment. Such a semi-final estimate payment will be based upon (a) quantities the Administration has computed and set up as proposed final quantities and (b) a reasonably accurate estimate for those quantities for which the Administration has not yet completed computations. The quantities which the Administration sets forth as proposed final quantities shall be so designated. To arrive at the amount of semi-final estimate payment there shall be deducted from the apparent estimated value of the Contract (a) total of all amounts previously paid to the Contractor as current estimates and (b) sums deemed chargeable against the Contractor properly deductible, including liquidated damages, and as a retainage, an amount equal to two percent (2%) of the total Contract value or two thousand dollars (\$2,000), whichever is greater.

(2) Partial Semi-Final Estimate Payments. In cases where there has been Partial Acceptance for Maintenance for a majority of the Contract Work as determined in the County's sole discretion and there are remaining only inconsequential or minor Contract Items such as painting, seeding, mulching, or planting to be completed and such Contract Items cannot be completed for an extended period of time because of seasonal or weather conditions, the Administration, within forty-five (45) Days from the most recent Partial Acceptance for Maintenance, upon request of the Contractor and with consent of Surety, shall pay to the Contractor, what is hereby known as a partial semi-final estimate payment. Such a partial semi-final estimate payment will be based upon (a) quantities the Administration has computed and set up as proposed final quantities and (b) a reasonably accurate estimate for those quantities for which the Administration has not yet completed computations. The quantities which the Administration sets forth as proposed final quantities shall be so designated. To arrive at the amount of the partial semi-final estimate payment, there shall be deducted from the apparent estimated value of the Contract (a) total of all amounts previously paid to the Contractor as current estimates, and (b) sums deemed chargeable against the Contractor properly deductible, including liquidated damages, and as a retainage, a sum equal to two percent (2%) of the total value of the Contractor or two thousand dollars (\$2,000), whichever is greater.

GP-9.04 FINAL ACCEPTANCE AND FINAL PAYMENT

(a) When the Contractor believes it has completed a Contract, and there has been a Final Acceptance for Maintenance in accordance with the provisions of GP-5.13(b), the Engineer will promptly proceed:

- (1) To make any necessary final surveys;
- (2) To complete any necessary computation of quantities; and

(3) To submit to the Contractor, within sixty (60) Calendar Days after Final Acceptance for Maintenance of the Work by the Engineer, for the Contractor's consideration, a written tabulation of the proposed final quantities. This written tabulation shall be accompanied by a written statement setting forth, as applicable: (a) the Additional Work performed under Change Orders and/or Contract Modifications; (b) the County-authorized extension of Contract Time; (c) the number of Days which have been charged against the Contractor as having been used to complete the Contract; and/or (d) any deductions, charges or liquidated damages which have been made or imposed against the Contractor by the County.

(b) The Contractor shall then have a period of twenty (20) Calendar Days, dating from the date upon which it received the written tabulation from the Engineer under Section GP-9.04(a), in which:

(1) To decide whether or not the Contractor will accept final payment based upon the Engineer's written tabulation; and

(2) To notify the Engineer, in writing, of the Contractor's decision. The Contractor may request an additional period up to ten (10) Calendar Days in which to notify the Engineer of its decision. In the event the Contractor notifies the Engineer that it protests final payment based on the Engineer's written tabulation, that notification shall outline the reason(s) for said protest.

(c) Upon receipt of a notification of acceptance as provided for in GP-9.04(b)(1) above (or in the event of no response), the County shall prepare the final estimate and final payment forms and submit the final payment check to the Contractor. Such action by the County shall be deemed to constitute final payment for all Work under the Contract.

(d) If, under the provisions of GP-9.04(b)(2) above, the Contractor notifies the Engineer of its protest and nonacceptance of the Engineer's written tabulation, the Engineer shall pay the Contractor a semi-final estimate, or an additional semi-final estimate in the event a semi-final estimate has already been paid, based upon the Engineer's written tabulation, with deductions for all prior payments. A retainage equal to one and one-half percent (1.5%) of the total value of the Contract shall be withheld by the Engineer. The acceptance of such semi-final estimate, or additional semi-final estimate, shall not be considered as a waiver on the part of the Contractor of its right to pursue its protest and press for Full and Final Completion and final payment.

(e) In the event the Contractor does not accept the Engineer's tabulation from GP-9.04(a) above and/or has outstanding a claim filed in accordance with GP-5.14, the Engineer and the Contractor shall confer at mutually convenient times and endeavor to reconcile all points of disagreement expeditiously. If such reconciliation is accomplished, the Engineer will promptly proceed with final payment on the reconciled basis and in accordance with the provisions of GP-9.04(c) above. If reconciliation is not accomplished within thirty (30) Days, the decision of the Engineer shall be submitted to the Director with a copy to the County Office of Law, Attention: County Attorney, as a dispute in accordance with GP-5.15 "Disputes". The Contractor's failure to timely comply with the provisions of GP-5.15 shall constitute a waiver by the Contractor of its right under GP-5.15, and final payment may be made by the County based on the Engineer's recommendation.

(f) All prior partial estimates and payments shall be subject to correction by the Engineer at the time of final payment and if the Contractor has been previously overpaid, as determined by the Engineer, the amount of such overpayment shall be set forth in the final payment forms and the Contractor hereby agrees that it will reimburse the Administration for such overpayment within six (6) months of receipt of such notice by the Engineer, and the Contractor's Surety will not be granted release from obligations under the terms of the Contract until reimbursement has been made in full by the Contractor. It is further agreed that the County can withhold any overpayment from any other accounts due and payable to the Contractor under any County contract.

(g) Payment for the full apparent value of the Contract thus determined shall become due and payable to the Contractor within ninety (90) Days after Full and Final Completion of the Contract, as provided in GP-8.11. Contractor's acceptance of final payment shall be considered a general release of any, all, and every claim and/or dispute against the County arising out of, or in any way connected with, this Contract and the Work.

(h) Neither Full and Final Completion nor final payment nor any provision in the Contract shall relieve the Contractor of responsibility for faulty Materials and workmanship. Unless otherwise specified, the Contractor shall remedy any defects and pay for any damage to other Work resulting therefrom that appears within the applicable warranty period. The County shall give notice of observed defects to the Contractor with reasonable promptness.

GP-9.05 LATE PAYMENTS – Reserved.

GP-9.06 INTEREST

Notwithstanding any other provision in the Contract, the Contractor hereby waives the right to predecisional interest. For purposes of this GP-9.06 and the Contract, "predecisional" means a decision by any Engineer or the County Administrative Officer, or his designee, or a decision by any Person including but not limited to an administrative hearing officer. The Contractor shall only be entitled to postdecisional interest, and for purposes of this GP-9.06 and the Contract,

Revised
October 11, 2013

“postdecisional” interest shall only begin to accrue, after the exhaustion of all administrative remedies and the rendering of a judgment by a court of competent jurisdiction.

GP-SECTION 10 PRIVATE CONTRACTS

GP-10.01 PRIVATE CONTRACTS

(a) A Private Contract is used in land development projects when, with the permission of the Director of the County Department of Permits, Approvals and Inspections, the Construction Contract is let by a developer and processed through the County. The applicable developer shall obtain the Bid privately and the cost estimates will be processed using County contract forms provided by the Department’s Division of Construction Contracts Administration or as approved by County for use with a UA and/or RA. No public funds may be used in a Private Contract. UA and RA are not governed by those provisions of these Standard Specifications which involve payment by developers to contractors.

(b) The following sections, as amended by the County, apply to Private Contracts:

- 107.03.02 (4)
- 204.03.07 B
- 1001.03.01(b)(2)
- 501.03.14
- 501.04.05
- 504.03.03 B
- 504.04

For Private Contracts, all references to the County (including Administration) in this GP-10.01 shall be construed to mean the developer as defined in the governing UA and/or RA in the Standard Specifications and in all references to making payments under the contract.

(c) IN ALL OTHER PORTIONS OF THESE STANDARD SPECIFICATIONS, REFERENCES TO THE COUNTY SHALL REMAIN UNCHANGED, WHETHER THE CONTRACT IS PUBLIC OR PRIVATE.

(d) Private Contracts may include fixed price Contingent Items to provide for certain contingencies encountered during Highway and utility Construction. If included in the Bid, unit prices shall be those established by the County.

- (1) Fixed Price Highway Contingent Items - Private Contract Only
See Section 109 of Category 100 “Preliminary”.
- (2) Fixed Price Utility Contingent Items - Private Contract Only
See Section 109 of Category 100 “Preliminary”.

- (3) Award and Execution of Contract - Private Contract Only [GP-3.03 Performance Bond and Payment Bond Requirements].

In GP-3.03(b) delete the words “twenty-five thousand dollars (\$25,000)” and substitute “two thousand dollars (\$2,000)”.

- (4) Unauthorized Work - Private Contracts Only [GP-4.08 Unauthorized Work].

Add the following new paragraph:

Any Work performed in excess of one hundred ten (110%) percent of the Private Contract Bid, or one hundred ten (110%) percent of the Private Contract Bid plus any Contract Modifications, between the developer and the Contractor, shall be considered unauthorized Work and shall not be paid for. The Contractor is advised to bring to the attention of the developer and the County, in writing, any impending overrun of the one hundred ten (110%) percent upset limitation at least two (2) weeks before having to stop work due to this limitation.

- (5) Interest - Private Contracts Only [GP-9.06 Interest].

Payment by the developer under GP-9.03(b)(1) “Semi- Final Estimate Payments” and GP-9.04 “Final Acceptance and Final Payment”, shall be due on receipt of the monthly estimates, semi-final estimates, and final estimates prepared by the Department and submitted to both parties in the amount shown as payable on this estimate. Any monies not paid within fifteen (15) Days of the date of such estimates shall bear interest at the rate of eighteen percent (18%) per annum. Interest shall be computed and invoiced by the Contractor and shall not be subject to a review or approval by the Department. However, the Department will not consider the developer’s Public Works Agreement obligations complete as long as the Contractor reports an outstanding indebtedness under the Private Contract.

- (6) Interim Acceptance - Development Bonds - Private Contract Only GP-9.03(b).

Add the following new paragraph:

When the Contractor postpones Road surfacing (during the course of completing a two-phased, 4-inch, paving section) its retainage shall be 2.0 percent after the bituminous Base Course has been accepted. Following a satisfactory re-inspection one (1) year after that acceptance, the retainage may be reduced to 0.0 percent.

GP 10.02 UTILITY/ROAD AGREEMENTS

These UA and/or RA are for projects wherein the applicant (developer, Persons, or property owners) constructs and installs improvements to utilities or Roads all at no cost to the County. The County Department of Permits, Approvals and Inspections (PAI), or any successor County department, in accordance with the applicable provisions of the County Code, as amended from

time to time, and the PAI Construction Policy Manual, approves the cost estimates and Construction Drawings and collects, except for County departments and agencies, the security and all fees. An applicant must provide to PAI, in writing, the name, address and phone number of an authorized Work site representative. The applicant must use a County prequalified Contractor who provides a certificate of insurance and performs the work in accordance with the Department's Standard Specifications and Standard Details in effect on the date of the Notice to Proceed. It is the applicant's responsibility to schedule an on-site pre-Construction meeting with the Department, the Department of Environmental Protection and Sustainability, or any successor County department, and the County prequalified Contractor. No Construction is to be performed prior to receiving a written Notice to Proceed from the Department.

**TC - SECTION 1
REFERENCES AND DEFINITIONS**

TC-1.03 METRIC SYSTEM – Reserved.

TC-1.04 LANGUAGE – Reserved.

**TC - SECTION 2
BIDDING REQUIREMENTS AND CONDITIONS**

TC-2.01 PROJECT CLASSIFICATION.

The Administration will estimate the cost of the Contract and classify it within one cost group and letter designation as follows:

COST GROUP ESTIMATE	COST GROUP LETTER CLASS
Up to \$ 100 000	A
\$ 100 001 to \$ 500 000	B
\$ 500 001 to \$ 1 000 000	C
\$ 1 000 001 to \$ 2 500 000	D
\$ 2 500 001 to \$ 5 000 000	E
\$ 5 000 001 to \$ 10 000 000	F
\$ 10 000 001 to \$ 15 000 000	G
\$ 15 000 001 to \$ 30 000 000	H
\$ 30 000 001 to \$ 50 000 000	I
\$ 50 000 001 to \$ 75 000 000	J
\$ 75 000 001 to \$ 100 000 000	K
Over \$ 100 000 000	L

The letter designation will be published as part of the Bid Package.

TC-2.02 IN-STATE PREFERENCE – Reserved.

TC-2.03 VALUE ENGINEERING CHANGE PROPOSALS.

The Contractor may submit to the Engineer, in writing, value engineering change proposals (VECP) for modifying the Contract Documents for the purpose of reducing the total cost of Construction without reducing design capacity or quality of the finished product. The Engineer will then forward the VECP to the Department’s Chief of the Bureau of Engineering and

Construction with recommended action. The decision to accept or deny the VECP will be made by the Department's Chief of the Bureau of Engineering and Construction. The Department's Chief of the Bureau of Engineering and Construction will be the sole and final judge of the acceptability of a VECP. The County will not consider appeals once this final decision is made. If a VECP is accepted by the County, net savings resulting from that VECP will be equally divided by the County and the Contractor. The Contractor may elect to pursue one of the following options when submitting a VECP:

Option 1 - Submit revised Plans, Contract Documents and estimate of savings to reflect the VECP; or

Option 2 - Submit a written concept of the VECP for tentative approval and if accepted, submit the detailed Plans, Contract Documents, and estimate for final approval at a later date.

Each VECP shall result in a net savings to the Contract cost without impairing essential functions and characteristics of the Contract Items or of any other part of the Work, including but not limited to service life, reliability, economy of operation, ease of maintenance, desired aesthetics and safety.

As a minimum, the Contractor shall submit the following information before final approval of a VECP may be given:

- (a) A statement that the revised Plans, Contract Documents, and estimate of savings are submitted as a VECP.
- (b) A statement concerning the basis for the VECP and benefits to the County together with an itemization of the Contract Items and requirements affected by the VECP.
- (c) A statement describing in detail any and all potential impacts to public convenience and/or safety.
- (d) A detailed estimate of the cost under the existing Contract and under the VECP.
- (e) Plans, Contract Documents and recommendations as to how the VECP changes shall be accomplished.
- (f) A statement as to the time by which an Extra Work Order adopting the VECP must be issued so as to obtain the maximum cost effectiveness. Typically, the County will require at least four (4) weeks to review and approve a VECP.
- (g) A revised Baseline schedule showing the impact of the VECP, and including in that revised Baseline schedule a four (4) week allowance for the County's review of such VECP.
- (h) The Contractor's engineering cost for the VECP.

The County will process the VECP in the same manner as prescribed for any other Contract Modification which would necessitate issuance of an Extra Work Order. The County may accept in whole or in part any VECP by issuing an Extra Work Order which will identify the VECP on which it is based. The County will not be liable to the Contractor for failure to accept or act upon any VECP submitted pursuant to these requirements nor for any delays to the Work attributable to any VECP. Until a VECP is effected by a Contract Modification, the Contractor shall remain obligated to the terms and conditions of the existing Contract. If an executed Extra Work Order has not been issued by the date upon which the Contractor's VECP specifies that a decision thereon should be made, or any other date as the Contractor may subsequently have specified in writing, the VECP shall be deemed rejected. The Extra Work Order effecting the necessary Contract Modification will establish the net savings agreed upon, will provide for adjustment in the Contract prices and/or Contract Time and will indicate the net savings to be equally divided between the Contractor and the County. The Contractor's costs for preparation of the VECP and the County's costs to review and administer the VECP will be deducted from the gross savings. The County reserves the right to include in the Contract any conditions it deems appropriate for consideration, approval and implementation of the VECP. The Contractor's fifty (50%) percent share of the net savings shall constitute full compensation for effecting all changes pursuant to the Contract. Acceptance of the VECP and performance of the Work thereunder will not change the Contract Time, unless specifically provided for in the Contract Modification authorizing the VECP.

The County expressly reserves the right to adopt a VECP for general use in contracts administered by the County when it determines that the VECP is suitable for application to other contracts. VECPs identical or similar to previously submitted VECPs will be eligible for consideration and compensation under these provisions if such VECPs were not previously adopted for general application to other contracts administered by the County. When a VECP is adopted for general use, compensation pursuant to these requirements will be applied only to those contracts Awarded and for which the subject VECP has been submitted prior to the date of adoption of the specific VECP.

Proposed changes in the basic design of a Bridge or pavement type, or requiring modification to the Right-of-Way limits, will not normally be considered as an acceptable VECP. Quantity decreases or elimination of any Contract Items as a result of changing field conditions, errors, etc. will not be considered as an acceptable VECP. If a VECP is based upon or similar to a change in the Plans, Contract Documents or Special Provisions adopted by the County prior to submission of the VECP, the County will not accept the VECP.

These requirements apply to all VECPs initiated and developed by the Contractor and which are identified as such by the Contractor at the time of its submission to the Engineer; however, nothing herein shall be construed as requiring the Engineer to consider or approve a VECP submitted by the Contractor.

Subject to the provisions contained herein, the County or any other public agency shall have the right to use all or part of any accepted VECP on other contracts without obligation or compensation of any kind to the Contractor.

In the event a VECP is accepted by the County, the provisions of the Contract Documents which pertain to adjustment of Contract unit prices due to alterations of Contract quantities will not apply to the items adjusted or deleted as a result of effecting the VECP by Contract Modification.

TC-2.04 OWNER/OPERATOR.

For the purpose of labor compliance, the term "Owner/Operator" shall be defined as being the individual who owns and operates his/her own vehicle.

The prevailing wage rates shall not apply to a "Owner/Operator". However, they shall appear on the payroll of the Contractor or Subcontractor with the notation "Owner/Operator".

Employees of an "Owner/Operator" shall be subject to prevailing wage rates and shall appear on a certified payroll.

TC-2.05 DEBARMENT/SUSPENSION.

Pursuant to the emergency regulations which were approved by the AELR Committee of the State General Assembly on July 27, 1982, and which went into effect on July 28, 1982, the State Department of Transportation, State Highway Administration, pursuant to applicable laws and regulation, established a list of "Debarred or Suspended Contractors."

The current list of "Debarred or Suspended Contractors or Suppliers" is available at the Baltimore County Department of Public Works, 111 West Chesapeake Avenue, Room 300, Towson, Maryland 21204, for inspection by all interested parties.

**TC - SECTION 3
SCOPE OF WORK**

TC-3.01 GOVERNING ORDER OF CONTRACT – Reserved.

TC-3.02 CONSTRUCTION DOCUMENTS TO SUCCESSFUL BIDDER – Reserved.

TC-3.03 CONTINGENT ITEMS – Reserved.

TC-3.04 WARRANTY OF CONSTRUCTION – Reserved.

TC-3.05 RIGHTS IN AND USE OF MATERIALS FOUND ON THE WORK SITE.

The Contractor may use on the Contract any excavated stone, gravel, sand or other Material found on the Work site that conforms to the requirements of the Contract Documents and are approved by the Engineer.

When these Materials are used for select, capping, modified, or common borrow and conform to the pertinent Contract provisions and Contract Documents, payment will only be made at the Contract unit price for the class of excavation from which the Materials are obtained.

In the event these Materials are processed through a crushing, screening, washing or sorting plant for use as another Pay Item, the Contractor will be paid both for the excavation of such Materials at the Contract unit price and at the Contract unit price for which the Material is used. The Contractor shall replace at its own expense with other acceptable Material all of the portion of the excavated Material removed and used which was needed for use in the embankments, backfills, approaches or otherwise.

If, however, these Materials are not processed and paid for as described in the preceding paragraph, and their use creates a shortage of embankment or other Material, the Contractor shall provide acceptable replacement Material for all Material needed for embankment, backfill, approaches or otherwise.

The replacement Material shall be paid for at the Contract unit price Bid for the Contract Item that the Class I Excavation is used for, or the Contract unit price Bid for Class I Excavation, whichever is the lowest Contract unit price Bid.

The Contractor shall not excavate nor remove any Material which is not within the limits of excavation, as indicated by the Slope and grade lines, without written authorization from the Engineer.

TC-3.06 SAFETY HAZARDS IN CONFINED SPACES – Reserved.

TC - SECTION 4 CONTROL OF WORK

TC-4.01 WORKING DRAWINGS.

(a) **General.** The Plans will be supplemented by Working Drawings as necessary to adequately control the Work. All alterations affecting the requirements and information given on the Working Drawings shall be authorized in writing to the Engineer. When at any time reference is made to the Working Drawings, the interpretation shall be the Working Drawings as affected by all authorized alterations then in effect.

Working Drawings will show details of all Structures, lines, grades, typical cross section of Roadway, general cross sections, location and designation of all units and elements.

Revised
October 11, 2013

The Contractor shall provide, at the Contractor's expense, all required Working Drawings and shall have them adequately checked, after which they shall be submitted to the Engineer for review. The Engineer may reject Working Drawings and return them for revisions, in which case the Contractor shall submit revised Working Drawings as required. No Contract Items involving the Working Drawings shall be incorporated into the Work until those Working Drawings have been accepted for use by the Engineer; however, acceptance shall not relieve the Contractor of any responsibility in connection therewith. All Working Drawings shall be furnished in duplicate for preliminary examination for Contracts prepared by the Administration and in triplicate for Contracts prepared by consultant engineering firms for the Administration. After Working Drawings have been accepted for use by the Engineer, the Contractor shall furnish additional copies as requested.

All Working Drawings shall be on sheets measuring twenty-two inches (22") by thirty-six inches (36") or as required by the Engineer and shall have a standard title block at the lower right corner approximately four inches (4") by eight inches (8") (two inches (2") for the revision column on the left side and the remaining six inches (6") for the title) indicating the following information in the order named:

- Name of Contractor (and Subcontractor, if applicable)
- Address of Contractor (and Subcontractor, if applicable)
- Sheet Title (Reinforcement Details, etc.)
- Name of Structure Crossing
- For (Baltimore County)
- By (Indicate name of Contractor's official or engineer, or other parties authorized to sign official documents.)

All Working Drawings shall list all County Contract Numbers, complete federal aid number, if any, and the date the Working Drawing was completed. The left portion of the title block shall be headed "Revisions" and the space used as needed.

Working Drawings for standard scuppers are not required. A sketch or statement specifying the type and number of standard scuppers required and the length of the downspout is acceptable.

(b) Working Drawings for Falsework Systems. Falsework systems Plans (design and Construction) shall be the responsibility of the Contractor, including submitting and obtaining written acceptance of the design and Plans by the Engineer before erection. The Contractor shall utilize a professional engineer (P.E.) registered in the State who has a minimum of five (5) years experience in falsework design for Bridge Construction and Repair. The falsework design calculations and Plans shall be signed by the P.E. and bear the seal of the P.E. The submittal of the design and falsework Plans shall include the P.E.'s resume showing evidence of the required experience.

The P.E.'s Plans and design calculations shall evaluate and qualify all products and components including manufactured products and proprietary items for their intended service. Acceptance by the Engineer of falsework systems shall not in any way relieve the Contractor of the responsibility for the safety and adequacy of the design and Construction for the falsework

systems and operations, including all components. Every Structure in the Contract will require a separate falsework design analysis, separate Plans, and separate design submittals as set forth above. This applies even though Structures may appear to be identical.

Each falsework system shall be designed to have the capacity to support all vertical and horizontal loading with enough redundancy to prevent progressive failure. Vertical loading, differential settlement forces, live load where applicable and all horizontal lateral and longitudinal forces shall be taken into account. Unbalanced temporary loading caused by placement sequence shall also be provided for in the design. Adequate diagonal bracing in all planes shall be employed.

All falsework systems designs and Plans shall provide for adequate foundations with bearings below the frost line or on rock or on piling and for possible settlement. If additional subsurface data is necessary, it shall be obtained and analyzed by the Contractor for proper design of the Plans and performance of Construction.

Falsework designs and Plans shall include protection against impact from uncontrolled Highway vehicles, accidental collision of a crane boom or other Construction Equipment and vehicles, traffic vibration, flood waters, high winds and any other envisioned contingent situations.

TC-4.02 FAILURE TO ADEQUATELY MAINTAIN PROJECT – Reserved.

TC-4.03 USE PRIOR TO COMPLETION – Reserved.

TC-4.04 WORK SUSPENSION – Reserved.

TC - SECTION 5 LEGAL RELATIONS AND PROGRESS

TC-5.01 INSURANCE – Reserved.

TC-5.02 NOTICE TO PROCEED – Reserved.

TC-5.03 SUBCONTRACTORS – Reserved.

TC-5.04 CULTURAL RESOURCES – Reserved.

TC-5.05 DETERMINATION AND EXTENSION OF CONTRACT TIME – Reserved.

**TC - SECTION 6
RESTRICTIONS AND PERMITS**

TC-6.01 MOVING OF EQUIPMENT.

(a) The Contractor will not be permitted to move over or operate on any Road (except on the Road under Construction) any power shovels, rollers, concrete mixers, cranes, tractors or any other heavy Equipment of weight or dimensions in excess of State Motor Vehicle Law or Administration's regulations without first obtaining the applicable permit. In case of permits for oversize and overweight vehicle movements, attention is directed to State Motor Vehicle Laws requiring the Administration to collect a fee on every such vehicle movement using Highways of the State. The payment of and securing of such permit is required irrespective of whether the movement is in connection with a subject Contract or for other purposes.

(b) The Contractor shall adhere to all State and local laws and regulations including but not limited to all State Motor Vehicle Laws and safety regulations.

TC-6.02 RESTORATION OF SURFACES OPENED BY PERMIT.

The right to construct or reconstruct any utility in a County Highway or to grant permits for same at any time is reserved by the Administration.

Upon the presentation of a duly authorized and satisfactory permit which provides that all necessary Repair Work shall be paid for by the party to whom such permit is issued, the Contractor shall allow parties bearing such permits to make openings in a County Highway.

The Contractor shall, when ordered by the Engineer, make in an acceptable manner all necessary Repairs due to such openings, and such necessary Work will be paid for as Extra Work, as provided in these Standard Specifications, and will be subject to the same conditions as original Work performed.

TC-6.03 RAILROAD HIGHWAY GRADE CROSSINGS AND SEPARATIONS.

When the Contractor is required to haul Materials across the tracks of any railroad, or elects to do so, the Contractor shall coordinate with and make arrangements with that railroad for any new private crossings or for the use of any existing private crossing in accordance with the terms and conditions of any permit issued by the applicable railroad.

All Work to be performed by the Contractor in the Construction of railroad-Highway separation Structures on the railroad right-of-way shall be done in a manner satisfactory to the railroad company and shall be performed at such times and in such manner as not to unnecessarily interfere with the movement of trains or traffic upon the tracks of the railroad company. The Contractor shall use care and precaution in order to avoid accidents, damage, or unnecessary delay or interference with the railroad company's trains or other property. In addition to the insurance specified in GP-7.14 and when Work covered under the Contract is to be performed on

or about the rails of a railroad's tracks, the Contractor shall be required to carry Contractor and railroad public liability and property damage insurance as specified in the Contract Documents and/or required by the applicable railroad.

Prospective Bidders on Contracts crossing railroad right-of-way are advised that the railroad company will require the Contractor to obtain, pay for and have approved by the railroad, certain railroad forms of public liability and property damage insurance policies before entering upon the railroad property. Details of such policies may be set forth in the Contract Documents; but in case of omission from the Contract Documents, the Contractor shall and is required to communicate with the railroad to ascertain the type of insurance required, if any, and make provisions for same in its Bid.

Unless otherwise specified, cost for the insurance policies whether described in the Contract Documents or ascertained by the Contractor will not be paid for by the County. The cost for any and all insurance related to a railroad company will be incidental to the other Contract Items specified in the Contract Documents and be the sole responsibility of the Contractor.

All Work on portions of Structures over railroad right-of-way shall conform to all rules and regulations of the owners of the right-of-way, including, but not limited to, any applicable railroad company. The Contractor is responsible for acquiring full knowledge of these rules and regulations and complying therewith to the satisfaction of the owners of the railroad right-of-way, including, but not limited to, any applicable railroad company.

TC-6.04 BRIDGES AND OTHER WORK IN OR OVER WATERS OF THE STATE.

All Work in, on or over waters under control of the United States Department of the Army and the Environmental Protection Agency of the United States shall conform to all applicable federal permits, rules and regulations. All such rules and regulations are hereby part of and incorporated into the Contract. The Contractor is cautioned and charged with the responsibility of obtaining complete knowledge thereof and compliance therewith.

The Contractor shall also comply with the provisions of all other applicable federal, State and local laws, permits, rules and regulations, and shall be knowledgeable of any and all pertinent laws and regulations of the State Department of Natural Resources and Maryland Department of Environment. All such laws, permits, rules and regulations are also hereby part of the Contract.

TC-6.05 USE OF EXPLOSIVES.

All blasting operations, including the storage and handling of explosives and blasting agents, shall be performed in conformance with the applicable provisions of the Standard Specifications and all other pertinent federal, State, and local laws and regulations. Whenever explosives are used, they shall be of such character and in such amount as is permitted by the State and local laws and ordinances and all respective agencies having jurisdiction over them.

The Engineer will at all times have the authority to prohibit or halt the Contractor's blasting operations if it is apparent that, through the methods being employed, the required results are not

being obtained, an unstable condition exists, or the safety and convenience of the public is being jeopardized. The Contractor shall not damage any adjacent property or Structures. A pre-blasting and post-blasting survey inspection is required to be performed by the Contractor.

(a) **Blasting Plan Required.** Not less than two (2) weeks prior to commencing drilling and blasting operations, or at any time the Contractor proposes to change the drilling and blasting methods, the Contractor shall submit a blasting plan to the Engineer for review. The blasting plan shall contain the full details of the drilling and blasting patterns and controls the Contractor proposes to use. The blasting plan submittal is for quality control and record keeping purposes.

Review of the blasting plan by the Engineer shall not relieve the Contractor of the responsibility for the accuracy and adequacy of the plan when implemented in the field. If at any time during the progress of the Work the method of drilling and blasting does not produce the desired result, the Contractor shall submit a revised blasting plan until a technique is arrived at that shall produce the desired results.

(b) **Responsibility.** Control of blasting is a major responsibility of the Contractor. The Contractor shall execute vibration control and shall at all times be responsible for damage caused by vibrations due to blasting or any of the Contractor's other operations.

(c) **Extraordinary care.** When the use of explosives is necessary for the prosecution of the Work, the Contractor shall use extraordinary care so as not to endanger life or property. Before the firing of any blast in areas where flying rock may result in personal injury or unacceptable damage to property or the Work, the rock to be blasted shall be covered with approved blasting mats, soil, or other equally serviceable material, to prevent flyrock.

(d) **Safeguard of Public.** The Contractor must safeguard the traveling public during dynamiting operations. The Contractor shall use enough watchmen, flagmen, signs, etc. to warn the public including, but not limited to, motorists and pedestrians during blasting.

(e) **Storage.** The Contractor shall store all explosives in a secure manner and shall clearly mark storage places "DANGEROUS - EXPLOSIVES". The storage places must be in the care of competent watchmen at all times and all explosives shall be stored and handled according to the provisions of the statutes of the State and local laws and ordinances.

(f) **Permits & Insurance.** Before any blasting is done, the Contractor shall apply for and obtain a blasting permit from the applicable governing authority. Insurance shall be maintained and certified as specified in GP-7.14.

(g) **Protection of Underground Utilities.**

(1) The Contractor shall ensure the protection of underground utilities. The Contractor shall notify each public utility company and those applicable Utility Companies having Structures close to the site of Work of the Contractor's intentions to use explosives. The notice must be given far enough in advance to enable all Persons and the Utility Companies to take such steps as they deem necessary to protect their property from injury. Such notice does

not relieve the Contractor of responsibility for any damage resulting from Contractor's blasting operations.

(2) At and below the elevation of the top of the buried utility line, the vertical depth of blast holes shall be restricted to one-half the horizontal distance to the closest portion of the utility. The blast hole shall be restricted to a maximum of three inches (3"), with no more than one hole per delay.

(h) **Peak Particle Velocity.** When blasting has to be done next to a Structure, the Contractor shall ensure that the "Peak Particle Velocity" at the Structure does not exceed 0.50 inches/second for frequencies less than 40 Hz. The "Peak Particle Velocity" is the maximum of the three-velocity components measured at a point with a three-component vibration recording instrument capable of producing a permanent record.

(i) **Maximum charge weight.** If a scaled distance, as defined below, of seventy (70) or greater is used with minimum delays of ten (10) milliseconds, the following formula may be used to determine the maximum charge weight per delay which can be used without seismic instrumentation:

$$\text{Scaled Distance} = \text{Actual Distance to Damage Point in Feet} (\text{Charge Weight in Pounds per delay})^{1/2}$$

$$\text{Charge Weight in} = (\text{Actual Distance to Damage Point in feet})^2 \text{ pounds per Delay} (\text{Scaled Distance})^2$$

(j) **Blast holes.** Blast holes are to be limited to three inches (3") in diameter. Prepackaged material only shall be used with no free flowing explosive permitted.

(k) **Use of Explosives Within State Road Right-of-Way.**

(1) The use of explosives is not permitted within rights-of-way of the State Highway Administration (SHA) except when specifically allowed under a SHA permit or by amendment of the same. The Contractor shall conduct and perform all blasting operations according to the permit and/or any addenda issued.

(2) Before using any explosives, notify the following office:

Utility Division
Maryland State Highway Administration
District No. 4
320 West Warren Road
Hunt Valley, Maryland 21030
Telephone (410) 229-2300

(l) Each blasting shall be seismographically recorded by the Contractor and the Contractor shall send a copy of the report to the SHA Highway District Utility Engineer at the above

address.

(m) Use of explosives. The use of explosives is not permitted within railroad rights-of-ways except when specifically allowed under a railroad permit or by amendment of the same. All blasting operations shall be conducted and performed according to the permit and/or any addenda issued.

(n) Payment for blasting. Payment of all blasting operations, control measures and monitoring systems shall be included in the unit price Bid for each Contract Item for which blasting is required.

TC-6.06 AERIAL ELECTRIC LINES (750 VOLTS OR MORE).

The Contractor shall be aware that State law requires that a ten foot (10') radial clearance shall be maintained for all Construction Equipment and Materials in relation to electric lines carrying seven hundred fifty (750) volts or more. Because the State law is more stringent than the federal laws, the State law shall be considered the minimal distance.

The Contractor shall also be aware of, and comply with, all other federal, State, County and local laws, utility company requirements and regulations, as specified in GP-7.01 "Compliance With Laws".

TC-6.07 LOAD AND SPEED LIMITATIONS – Reserved.

TC-6.08 HAZARDOUS MATERIAL.

If the Contractor encounters or exposes during Construction any abnormal conditions which indicate the presence of a hazardous material or toxic waste, Work in the area shall immediately be suspended and the Engineer notified in writing. The Contractor's operations in this area shall not resume until permitted in writing by the Engineer; however, the Contractor may continue working in other areas of the Work site, unless directed otherwise.

Abnormal conditions shall include, but not be limited to, the presence of barrels, obnoxious or unusual odors, excessively hot earth, smoke, or any other condition which could be a possible indicator of hazardous material or toxic waste.

Disposition of the hazardous material or toxic waste shall be made in conformance with all applicable laws, requirements and regulations. Where the Contractor performs necessary Work required to dispose of these Materials and no Contract Items have been identified in the Contract Documents, the Work shall be performed under an Extra Work Order.

For any Material furnished in connection with the Contract and/or on the Work site by the Contractor that is suspected to be hazardous or toxic, the Engineer may require the Contractor to have it tested and certified to be in conformance with all applicable requirements and regulations. Material found to be hazardous or toxic shall not be incorporated into the Work.

The required testing will be determined by the Engineer and may include, but not be limited to, the EPA Toxicity Characteristic Leaching Procedure (TCLP) or its successor. The evaluation and interpretation of the test data will be made by the Engineer. Testing and Certification shall be at the Contractor's sole expense.

TC-6.09 RECYCLED OR REHANDLED MATERIALS.

For recycled or rehandled Material furnished on the Work site by the Contractor for use in embankment, base, Subbase or drainage media, the Engineer may require the Contractor to have the Material tested and certified to be in conformance with all applicable environmental requirements. The required testing will be determined by the Engineer and may include, but not be limited to, the EPA Toxicity Characteristic Leaching Procedure (TCLP) or its successor. The evaluation and interpretation of the test data will be made by the Engineer and be based on the Work site environment. Testing and Certification shall be at the Contractor's sole expense.

TC-6.10 CONSTRUCTION AND WASTE MATERIAL.

All wood, trash, debris, and other foreign matter shall be removed from within the Right-of-Way limits and disposed of by the Contractor. The Contractor shall make all necessary arrangements to obtain suitable disposal locations at the Contractor's sole expense. Disposal shall be in conformance with all federal, State and local ordinances.

**TC - SECTION 7
PAYMENT**

TC-7.01 MEASUREMENT OF QUANTITIES – Reserved.

TC-7.02 PAYMENT ALLOWANCES FOR STORED MATERIALS – Reserved.

TC-7.03 FORCE ACCOUNT WORK – Reserved.

TC-7.04 PROGRESS PAYMENTS – Reserved.

TC-7.05 FINAL ACCEPTANCE AND FINAL PAYMENT– Reserved.

TC-7.06 LATE PAYMENTS – Reserved.

351.03.10 Chlorination, Bacteriological, Hydrostatic and Leakage Tests.

(b) Water Samples. Baltimore City Bureau of Water and Wastewater will perform bacteriological testing for the disinfection of water mains and storage facilities according to ANSI/AWWA C651, Section 5.1.1, 5.1.2, 5.1.4, and 5.2. It is required that two consecutive sets of samples be taken at least 24 hours apart and deemed acceptable by bacteriological standards before a water main or storage facility can be placed into service.

The engineer will collect water samples and provide for their analysis for bacteriological quality. Samples must arrive at the Water Quality Lab no later than 6 hours after being taken. Because bacteriological analysis will be run on samples received in the lab by 1:00 pm, all field sampling must be completed by 12:00 noon. Results will be available after 3:00 pm the following day, as the results require a full 24 hour incubation period.

MAINTENANCE BOND

Per the Baltimore County Department of Public Works Standard Specifications for Construction and Materials, Section GP -4 .10 (C) of the Errata Addenda states, the contractor is required to post a maintenance bond in the amount of five (5) percent of the total cost of the contract or withhold five (5) percent retainage for two (2) years from the date of Final Acceptance. Maintenance Bond forms are located within this Errata Addenda.

BALTIMORE COUNTY, MARYLAND

BOND NO. _____

CONTRACT NO. _____

MAINTENANCE BOND

THIS MAINTENANCE BOND is entered into on this _____ day of _____, 20____, by and between _____ as principal ("Principal") and _____, a business entity that is authorized to transact business in the State of Maryland and is organized and existing under the laws of the State of _____, as surety ("Surety"), are held and firmly bound unto Baltimore County, Maryland, a body corporate and politic of the State of Maryland ("County"), as Obligee.

WHEREAS, the above-named Principal has entered into a written contract known as _____ No. _____ dated _____, 20__ with Obligee for _____ (the "Agreement"), the terms of which are hereby incorporated by reference; and

WHEREAS, Principal has completed construction under the Agreement; and

WHEREAS, the Agreement includes a warranty on the quality of the Work performed that runs for a period of two (2) years from the date of the County's final acceptance and that runs for two (2) additional years beyond the repair date if any repair is done during the warranty period; and

WHEREAS, Principal is required to cause this instrument to be executed and delivered to Obligee as security for maintenance during the warranty period in an amount equal to 5% of the total value of the Contract.

NOW, THEREFORE, the Principal and Surety are held and firmly bound unto the Obligee in the sum of \$_____ Dollars (\$ _____), lawful money of the United States of America, for the payment of which sum of money the Principal and Surety do bind themselves and their personal representatives, legal representatives, successors, and assigns, jointly and severally, firmly by this maintenance bond.

The conditions of this bond are as follows:

1. The Principal shall, for a period of two (2) years from and after the date of completion and acceptance of same by Obligee, replace all defects arising in the Work, whether resulting from defective materials, equipment, design furnished or workmanship. After such period, this obligation shall be null and void; otherwise it shall remain in full force and effect.

2. In the event of a default on the part of the Principal that may be the subject of a claim under this bond, Obligee shall mail, by certified mail, to Surety at the address listed below, a written statement that a claim is being made under the bond and, with substantial accuracy, the amount of the claim. Surety shall have no obligation to Obligee under this bond until the notice of claim is mailed.

3. When the Obligee has satisfied the condition of Paragraph 2 that a notice of claim be mailed, the Surety shall promptly and at the Surety's expense send an answer to Obligee within 30 days after the date of the claim. The answer shall state the amounts that are undisputed and the basis for challenging any amounts that are disputed. The answer shall be accompanied by payment (or arrangements for immediate payment) of any undisputed amounts.

4. Surety expressly waives any right to receive notice of extensions of time or alterations or modifications to the Agreement that may be granted by Obligee and agreed upon by Principal, and any such extensions, alterations, or modifications shall not affect the obligation of the Surety under this bond.

5. This bond is a specialty governed by the twelve-year statute of limitations period set forth in the Annotated Code of Maryland Courts and Judicial Proceedings §5-102.

WITNESS OR ATTEST:

(Principal – Contractor Name)

By: _____

Type Name: _____

Type Title: _____

Date: _____

(Surety)

By: _____

Type Name: _____

Type Title: _____

Type Address: _____

Date: _____

CONTRACT NO. 24066 P00

S E C T I O N III

SPECIAL PROVISIONS

**SPECIAL PROVISIONS
BIDDER PROTEST AND APPEAL
DPW CONSTRUCTION CONTRACTS**

STEP 1A – Bidder Protest of Award

Bidder must file a written bid protest pursuant to Section GP-2.23 of the Standard Specifications – see below. *A bid protest must be in writing and filed with the Engineer.*

Oral objections, whether or not acted on, are not protests.

(a) Time for Filing.

(1) A bid protest shall be filed not later than three (3) business days after the date of award.

(2) A protest based on alleged improprieties in the solicitation which are apparent before the bid opening or the closing date for receipt of initial proposals shall be filed not later than five (5) business days before the opening date.

(b) Content of Written Protest.

(1) Name and address of protestor.

(2) Bid or Contract number.

(3) Reasons for protest.

(4) Supporting exhibits, evidence or documents to support claim.

STEP 1B – Bidder Protest of Bid Rejection

Bidder must file a written bid protest with the Engineer not later than three (3) business days from the date of the bid rejection. Oral objections, whether or not acted on, are not protests. The written bid protest must comply with Section GP-2.23(b) of the Standard Specifications.

STEP 2 – DPW Response to Bidder Protest

The Department of Public Works (DPW), Chief of Division of Construction Contracts Administration will review the bidder's protest and respond to the bidder in writing within ten (10) working days of receipt of protest.

STEP 3 – Bidder Appeal

Bidder may appeal the decision by the Chief of Division of Construction Contracts Administration (a) to the Director of the Office of Budget & Finance for all MBE/WBE-related protests or (b) to the Director of Public Works for all other protests.

Bidder must file a written appeal with the relevant Director not later than three (3) business days from the date of the DPW Response in Step 2. Oral objections, whether or not acted on, are not appeals. The appeal must comply with Section GP-2.23(b) of the Standard Specifications, but may include any additional documentation as deemed necessary and appropriate by the bidder.

STEP 4 – Director Response to Bidder Appeal

The Director of the Office of Budget & Finance or the Director of Public Works will review the bidder's appeal and respond to the bidder in writing within fifteen (15) working days of receipt of appeal.

STEP 5 – Second Bidder Appeal

Bidder may appeal the decision by the Director of the Office of Budget & Finance or the Director of Public Works to the County Administrative Officer (CAO).

Bidder must file a written appeal with the CAO not later than three (3) business days from the date of the Director Response in Step 4. Oral objections, whether or not acted on, are not appeals. The appeal must comply with Section GP-2.23(b) of the Standard Specifications, but may include any additional documentation as deemed necessary and appropriate by the bidder.

STEP 6 – CAO Response to Bidder Appeal

The CAO, or his duly authorized designee, will review the bidder's appeal and respond to the bidder in writing within Twenty (20) Working days of receipt of appeal. The CAO's, or his duly authorized designee's, written decision is final and binding.

The Contract shall be done in strict compliance with the Baltimore County Department of Public Works February 2000 "Standard Specifications for Construction and Materials" and "Standard Details for Construction", and any and all revisions thereto as of the date of the fully executed Contract, including but not limited to the supplemental specification known as Addendum 3 and General Conditions Building Projects, as applicable, and all of which are made a part hereof and incorporated herein (collectively, the "Specifications"). Copies of the revisions are on file and available at the Division of Construction Contracts Administration, County Office Building, Towson, Maryland, and are on the County's website at <http://www.baltimorecountymd.gov/Agencies/publicworks/standardsandspecs/specsanddetails.html>. **IN ADDITION, THE CONTRACTOR UNDERSTANDS AND AGREES THAT THE FOLLOWING SECTIONS OF THE SPECIFICATIONS (GP-1.03 AND GP-5-15) SHALL BE STRICKEN AND THE FOLLOWING SHALL BE INSERTED IN AND INCORPORATED INTO THE CONTRACT IN LIEU THEREOF:**

GP-1.03 ORGANIZATIONAL DEFINITIONS

Administration - Baltimore County.

Administrator - The Director of the Office of Budget and Finance, Baltimore County.

Baltimore County - Baltimore County, Maryland: a body corporate and politic.

Department - The word "Department" shall mean the Office of Budget and Finance of Baltimore County.

Engineer - One of the following engineering executives:

Director of Office of Budget and Finance
Chief, Property Management Division of the Office of Budget and Finance

Any delegation of the Engineer's authority must be authorized in writing by any one of the above listed officials, and such delegation of authority will pertain only to the specific contract and/or contracts shown by the authorization. The title of the specific official will appear in those cases within these specifications where the word "Engineer" as defined herein is not sufficiently specific.

Inspector - The authorized representative of the procurement officer assigned to make detailed inspection of any or all portions of the work, or materials therefor.

Procurement Officer - See Engineer.

GP-5.15 DISPUTES

(a) Except as otherwise may be provided by applicable law or regulation, all disputes arising under or as a result of a breach of this Contract that are not disposed of by mutual agreement shall be resolved in accordance with this General Provision.

(b) As used herein, "claim" means a written demand or assertion by one of the parties seeking, as a legal right, the payment of money, adjustment or interpretation of Contract terms, or other relief, arising under or relating to this Contract.

A voucher, invoice, or request for payment that is not in dispute when submitted is not a claim under this General Provision. However, if the submission subsequently is not acted upon in a reasonable time, or is disputed either as to liability or amount, it may be converted to a claim for the purpose of this General Provision.

(c) When a claim cannot be resolved by mutual agreement, the Contractor shall submit a written request for decision to the Department's Chief of the Property Management Division for his decision in consultation with the County Office of Law. The Contractor's written request shall set forth all the facts surrounding the controversy, including, but not limited to, those items listed in GP-5.14(b). Any claim by the County shall be decided in like manner.

(d) The Contractor, at the discretion of the Engineer, may be afforded an opportunity to be heard and to offer evidence in support of his claim. Pending resolution of a claim, the Contractor shall proceed diligently with the performance of the Contract.

(e) The Department's Chief of the Property Management Division shall decide any and all claims. The decision by the Department's Chief of the Property Management Division shall be issued within ninety (90) Days on matters of less than fifty thousand dollars (\$50,000) and within one hundred eighty (180) Days on matters of fifty thousand dollars (\$50,000) or more. The written decision of the Department's Chief of the Property Management Division shall be final and binding unless appealed in writing to the Director of the Department within thirty (30) Days of the Chief's written opinion to the parties. If the Chief's decision is timely appealed in writing to the Director of the Department, the Director of the Department, serving as referee, will review the written appeal submitted to assure all reasonable attempts were made to resolve the appeal.

(f) The Director shall issue his/her decision in writing within ninety (90) Days. The Director's decision shall be final and conclusive unless a written appeal is mailed or otherwise filed with the County Administrative Officer within thirty (30) Days of the Director's written decision.

(g) When the County Administrative Officer is satisfied all efforts at the Department level were made to resolve the dispute, a claim shall be resolved as follows:

(1) Subject to, and without in any way enlarging or limiting the other provisions of the Contract, the parties to any Agreement which adopts or incorporates by reference these Standard Specifications, appoint the County Administrative Officer as an administrative hearing officer pursuant to Article 25A, "Chartered Counties of Maryland", of the Annotated Code of Maryland.

(2) The parties further grant the County Administrative Officer the right to delegate this responsibility and authority in writing to a County official who is a registered professional engineer, independent of the Department of Public Works's Division of Construction Contracts Administration, or to any other County official.

(3) For disputes involving ten thousand dollars (\$10,000) or more the decision of the administrative hearing officer shall be final and binding on both parties, subject only to such appeals on the record as provided by Article 25A. For disputes involving less than ten thousand dollars (\$10,000), the decision of the administrative hearing officer shall be final and binding on both parties.