

Liberty Pumps®

FL100-Series

1hp

Submersible Effluent Pumps

1-1/2" or 2"
Discharge

Flange Mounted

Features:

- 3/4" Solids-handling
- Heavy cast iron construction
- Semi-open cast iron impeller
 - Stainless steel rotor shaft
 - Dual shaft seals
- Single float, mercury free level control
- Additional mounting clamp provided for optional switch mounting to pipe
 - Fully adjustable pumping range
- 2" FNPT threaded discharge with 1-1/2" FNPT flange provided
- Quick-disconnect power cord - 25' length standard
 - Available in automatic and manual models



POWDER
COATED
TOUGH™

3
Year Warranty

**Dual Sized
Discharge**

1-1/2" or 2"

innovate. evolve.

FL100-Series

Technical Specifications

External Construction:

Pump Volute – Gray iron casting class 25
 Pump Legs – Gray iron casting class 25
 Motor Cover – Gray iron casting class 25
 All casting shall be powder coated for corrosion resistance prior to assembly.

Motor:

Submersible 3450 RPM, oil filled and hermetically sealed. Class B insulation rating. FL100 only 17-4 PH Stainless steel. Thermally protected – single phase models. Three phase models shall have overloads incorporated into the control panel, properly sized for the horsepower and amperage of the pump.

Impeller:

Semi-open design. Cast iron construction.

Dual Shaft Seals:

FL100-Series feature upper unitized carbon ceramic and lower Viton double lip.

Fasteners:

All fasteners shall be 300-series stainless steel.

Power Cord:

25' length standard. Quick-disconnect design allows easy field replacement. (35' and 50' available on 3-phase)

Level Control:

The pump shall be controlled by a wide angle mechanical float sealed in a PVC housing. The float shall have a series plug for manual by-pass operation.

A water-stop seal shall be incorporated into the cord entry to eliminate potential water wicking into the switch.

An adjustable clamp is provided for optional pipe mounting of the float.

Discharge:

2" FNPT with 1-1/2" FNPT cast iron flange provided.

Maximum Fluid Temperature:

104° F (40° C) Continuous Duty

140°F (60° C) Intermittent

Models	hp.	Volts	Phase	Amps	Discharge	Automatic	Cord Length	Wgt. Lbs.
FL102M-2	1	208-230	1	12	1-1/2" & 2"	No	25'	71
FL102A-2	1	208-230	1	12	1-1/2" & 2"	Yes	25'	72
FL103M-2	1	208/230	3	9	1-1/2" & 2"	No	25'	71
FL104M-2	1	440-480	3	4.5	1-1/2" & 2"	No	25'	71
FL105M-2	1	575	3	3.3	1-1/2" & 2"	No	25'	71

NOTE: 3-phase models require a control panel for automatic operation. See control panel literature for complete specifications on panels. 35' and 50' cord options available on 3-phase models. Add "-3" suffix or "-5" suffix to model number. Example: FL103M-3 for 35' cord, FL103M-5 for 50' cord.

60 hz Performance Curve FL100-Series

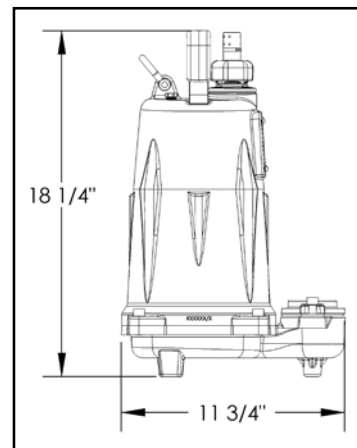
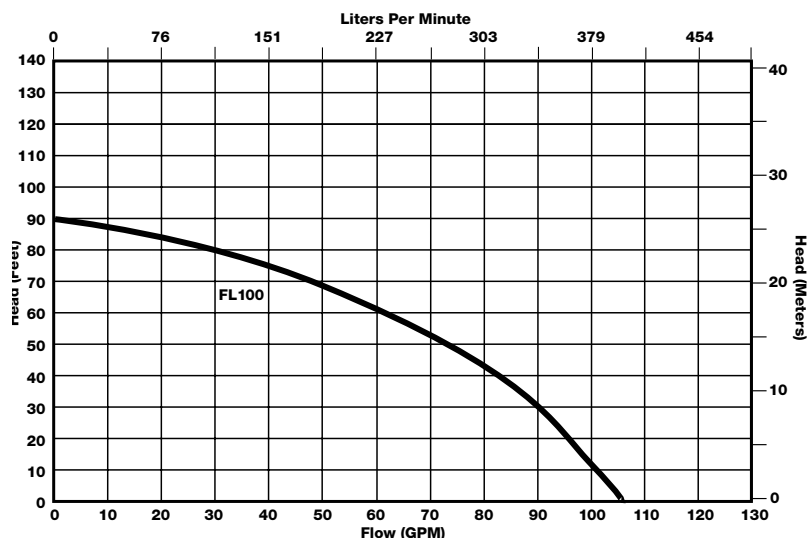

Specifications subject to change without notice.

Certified