



Valve Standard:
Conforms to AWWA C508
Clear Waterway

Working pressure:
21 BARS/300PSI

Fusion Bonded Epoxy
Coated Exterior RAL3002

Flanged Ends:
ANSI B16.1
Class150
EN1092-2 PN10/PN16/PN25
BS10 Table E
Flanged Ends Available

Material List

Name	Material
Seat Ring	EPDM Commercial
Hinge Pin	Stainless Steel AISI 304
Retainer Washer	Bronze ASTM B62
Clapper Arm	Ductile Iron A536 65-45-12
Cover	Ductile Iron A536 65-45-12
Body	Ductile Iron A536 65-45-12
Clapper	Ductile Iron A536 65-45-12

Dimensions (mm)

DN	L	H	Weight
50 (2")	203 (8.00")	122 (4.80")	12kg
65 (2.5")	254 (10.00")	133 (5.23")	17.5kg
80 (3")	279 (11.00")	136.5 (5.23")	22kg
100 (4")	330 (13.00")	162.5 (6.40")	34kg
125 (5")	356 (14.00")	296 (11.65")	58kg
150 (6")	406 (16.00")	298.5 (11.75")	67.3kg
200 (8")	495 (19.50")	357 (14.06")	120kg
250 (10")	559 (22.00")	410 (16.14")	174kg
300 (12")	660 (26.00")	465 (18.31")	246kg

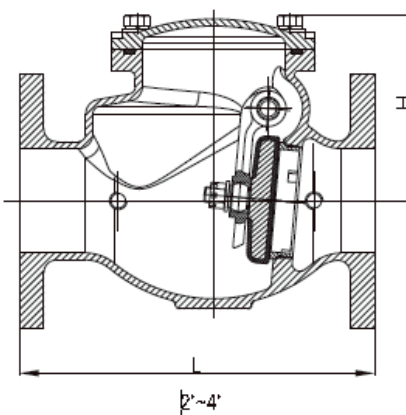
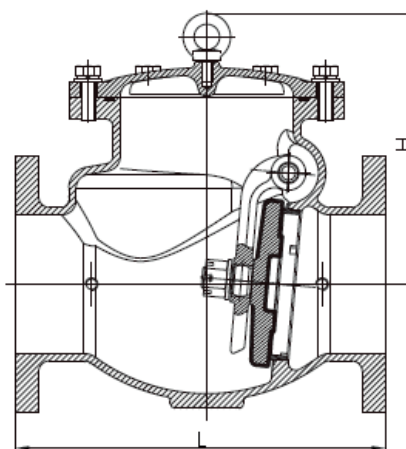

Product Information:

Description	Size (mm)	Part Number
Flanged Check Valve Resilient Seat FL/FL PN16	50 (2")	special order
Flanged Check Valve Resilient Seat FL/FL PN16	65 (2.5")	7U99002078
Flanged Check Valve Resilient Seat FL/FL PN16	80 (3")	7U99002079
Flanged Check Valve Resilient Seat FL/FL PN16	100 (4")	7U99002080
Flanged Check Valve Resilient Seat FL/FL PN16	125 (5")	special order
Flanged Check Valve Resilient Seat FL/FL PN16	150 (6")	7U99002081
Flanged Check Valve Resilient Seat FL/FL PN16	200 (8")	7U99002082
Flanged Check Valve Resilient Seat FL/FL PN16	250 (10")	7U99002083
Flanged Check Valve Resilient Seat FL/FL PN16	300 (12")	7U99002084

Product Information:

Description	Size (mm)	Part Number
Flanged Check Valve Resilient Seat FL/FL ANSI	50 (2")	7U99001958
Flanged Check Valve Resilient Seat FL/FL ANSI	65 (2.5")	7U99001820
Flanged Check Valve Resilient Seat FL/FL ANSI	80 (3")	7U99001821
Flanged Check Valve Resilient Seat FL/FL ANSI	100 (4")	7U99001822
Flanged Check Valve Resilient Seat FL/FL ANSI	125 (5")	special order
Flanged Check Valve Resilient Seat FL/FL ANSI	150 (6")	7U99001823
Flanged Check Valve Resilient Seat FL/FL ANSI	200 (8")	7U99001824
Flanged Check Valve Resilient Seat FL/FL ANSI	250 (10")	7U99001825
Flanged Check Valve Resilient Seat FL/FL ANSI	300 (12")	7U99001826

Notes:

1. Flanged to ANSI B16.1 125# other flange types available.
2. Fusion bonded epoxy coated interior and exterior.
3. Rated at 400PSI for protection service.
4. Design and materials are subject to change without notice.