

SafeZone™ Up to TL-4 Limited Deflection

leading the way in portable road barriers



Leading the way in work zone positive protection, SafeZone barrier from Laura Metaal Road Safety is the first MASH approved TL-4 Standard and Minimum Deflection steel barrier. Offering the narrowest footprint on the market at 18 inches SafeZone is the ideal barrier for bridge rehabilitation or confined work zones where every inch counts.

Our Quick Connect system allows rapid deployment of barrier at 1,000 feet per hour and numerous anchoring options ensure exact placement no matter what type of surface you encounter. Save over 80% on truck transportation costs while reducing carbon emissions versus portable concrete barrier.

**Up to TL-4
Limited
Deflection**



SafeZone has a life cycle that far exceeds the current industry standards.

Our list of optional attachments from gawk screen, to wheels, to a wide assortment of angle pieces ensure your project will be installed with state of the art barrier technology.

Laura Metaal Road Safety proudly offers a complete line of TL-2, TL-3 and TL4 rated steel barriers to ensure positive protection for your workers and the motoring public.

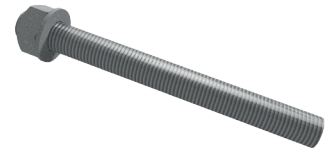
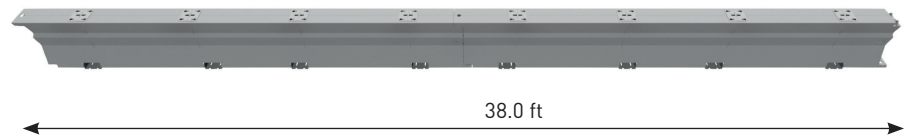
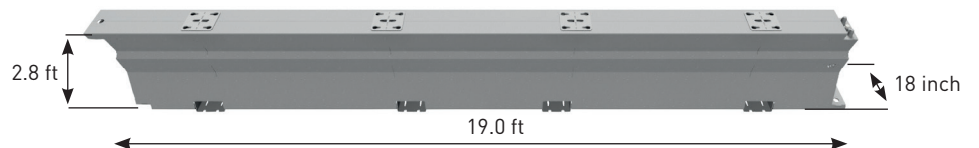

Advantages of the SafeZone:

- + first MASH approved TL-4 standard and minimum deflection steel barrier
- + quick connect for rapid deployment
- + save over 80% on truck transportation costs
- + robust due to high strength steel
- + 20+ year estimated lifespan
- + maintenance free

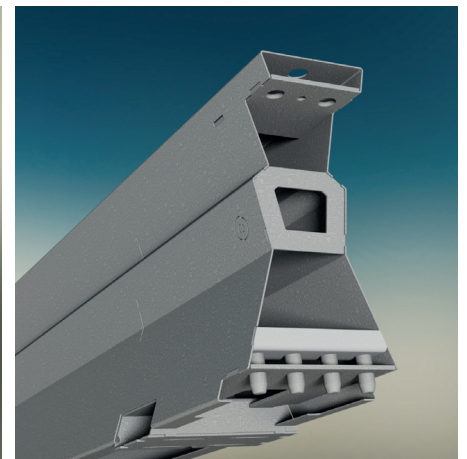
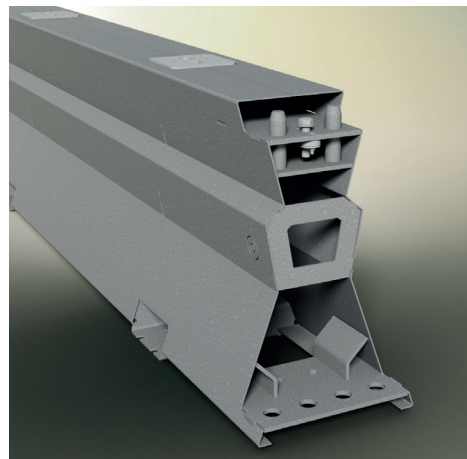

Product	Testnorm	Vehicle class	Impact speed	Impact Angle	Test Result	Dynamic Deflection
SafeZone	TL3-11	2270p	62 mph	25°	Pass	66.9 inch
SafeZone	TL3-11 Limited Deflection	2270p	62 mph	25°	Pass	23.8 inch
SafeZone	TL4-12	10000s	56 mph	15°	Pass	81.5 inch
SafeZone	TL4-12 Limited Deflection	10000s	56 mph	15°	Pass	16.5 inch

For more information, please contact Laura Metaal Road Safety:

Tel: 1-800-674-9908

E-mail: info@laurametaalroadsafety.com

Website: www.laurametaalroadsafety.com

