



**C.R.I.
SUBMERSIBLE
MOTORS - 60Hz**



C.R.I. MOTORS

Pumping trust. Worldwide.

T H E B E G I N N I N G

of C.R.I., way back in 1961, was a resolute attempt to produce a few irrigation equipments using the limited facilities of an in-house foundry. Eventually the founder's dream was coming true as the small production unit he started kept growing rapidly. Now, after more than five eventful decades, it is an enormous, widely reputed organization, which produces more than 2300 varieties of perfectly engineered pumps and motors and sells its products in numerous countries spread across 6 continents.

C . R . I . I S O N E A M O N G

the few pioneers in the world to produce 100% stainless steel submersible pumps. Having achieved a record production capacity of over 2 million pumps per annum, today C.R.I. is rubbing its shoulders with the best brands in the world, with advanced technology and safety standards as its hallmarks.

T H E I N F R A S T R U C T U R E

of C.R.I. is pretty comprehensive with state-of-the-art machineries and high potential in-house R&D recognised by the ministry of science and technology, Govt. of India - all within its own covered area of 300,000 square metres. The production environment is accredited with ISO 9001, ISO 14001 & OHSAS 18001 certifications and the products are CE, UR/UL, IEC, TSE & ISI certified. The R&D team always stays in tune with the changing scenario and seldom fails in coming up with outstanding solutions every time.

N E E D L E S S T O S A Y ,

behind this legendary growth lies the untiring, innovative, enthusiastic and dedicated team work. and, of course, a flawlessly maintained value system too. The name C.R.I. itself encapsulates the company's ethos: "Commitment, Reliability, Innovation".





C.R.I. MOTORS
Pumping trust. Worldwide.

Vision, Mission and Values

To be the industry leader providing best - in - class fluid management solutions to individual and institutional customers and societies in our chosen markets.

We will achieve this through our dedicated efforts to enhance the welfare of all our stakeholders and by living by our values of **commitment, reliability and innovation.**

C O N T E N T S

	Page No.
MODEL IDENTIFICATION CODE	3
RESIN FILLED ENCAPSULATED SUBMERSIBLE MOTORS	
4" Motors Description, Features and Applications Specifications and Materials of Construction Exploded View Technical Data	4 5 6 7
RESIN FILLED ENCAPSULATED SUBMERSIBLE MOTORS	
Description, Features and Applications 4" Motors Specifications and Materials of Construction Exploded View Technical Data 6" Motors Specifications and Materials of Construction Technical Data	8 9 10 12 14 15
WATER FILLED REWINDABLE SUBMERSIBLE MOTORS	
Description, Features & Applications Exploded View 4" Motors Specification and Materials of Construction Technical Data 6" Motors Specifications and Materials of construction Technical Data 8" Motors Specifications and Materials of Construction Technical Data 10" Motors Specifications and Materials of Construction Technical Data 12" Motors Specifications and Materials of Construction Technical Data Cable Selection Table Conversion Table	16 17 23 24 25 26 29 30 31 32 33 34 35 38

MODEL IDENTIFICATION CODE

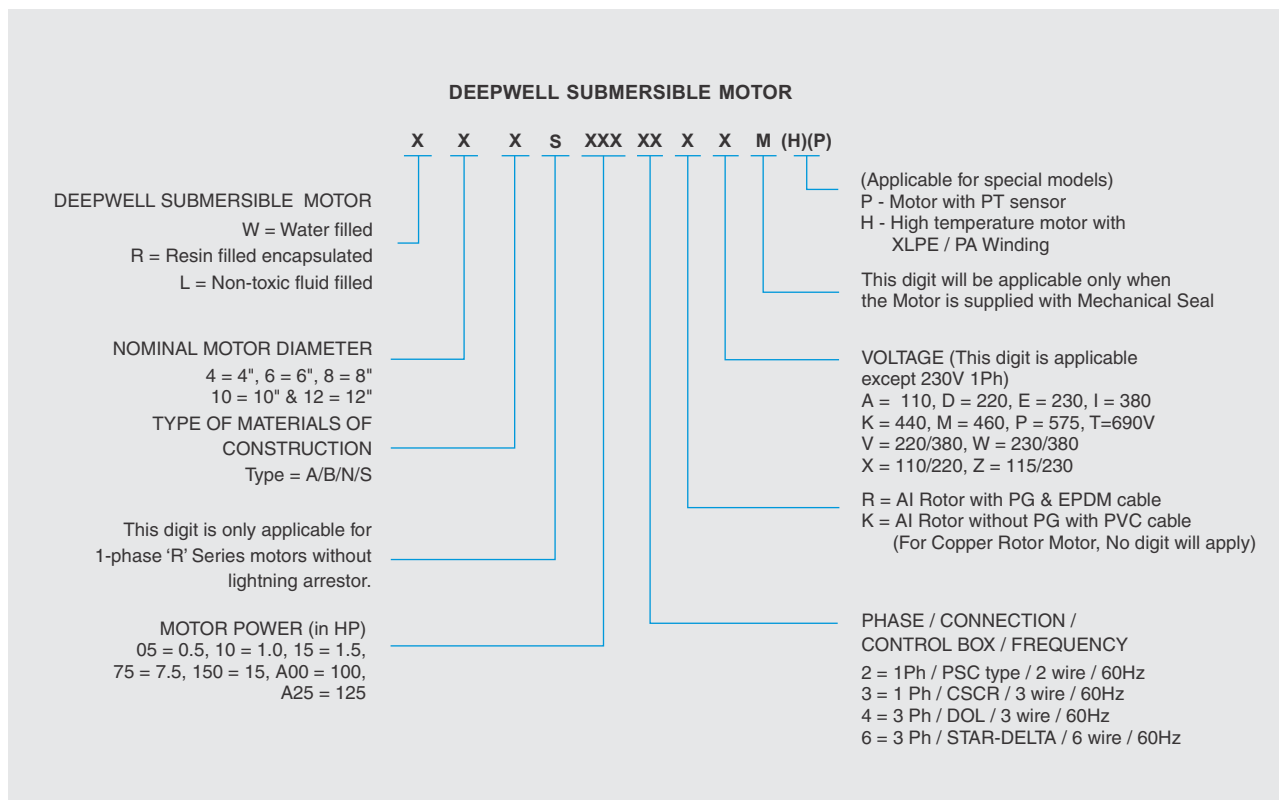

OIL FILLED SUBMERSIBLE MOTORS

Nominal Diameter : **4"**

"L" Series

Deepstar

Description

These oil filled motors are one among the proven & successful products from the house of C.R.I. These motors are developed with due diligence complying with all safety standards and giving importance to the customers' need. All the components that are in contact with water are made of AISI 304 stainless steel and the motor is pre-filled with edible grade oil, which acts as coolant media as well as lubricant. The freezing point of the oil used is -10°C.

Ball bearings are used to withstand the high axial load and the lower ball bearings are of angular contact type.

High quality carbon/ceramic mechanical seal and oil seal made of Nitrile rubber are used to ensure better sealing system. Pressure equalizing rubber diaphragm is provided to balance the pressure and volume variations due to thermal expansion of the oil inside the motor. Motor sealing are made by means of 'O' rings. Shaft seals and sand guard prevents ingress of well water, sand and fiber particles into the motor. Care should be taken to ensure that the motor does not run when it is not submerged in the water. To prevent the motor from dry running, install water level monitor / dry run prevent. The motor needs a constant flow of water passed over it's body to keep it at correct operating temperature. Ideally the motors should be set just above the final yield point of bore well and when the level is not ascertained, fit a "flow inducer pipe" over the pumpset to ensure adequate cooling. It is mandatory to use C.R.I. Control boxes for all motors with adequate protection & control systems. Mounting dimensions of these motors are in accordance with NEMA standard.

Features

- High operating efficiency and lesser power consumption
- Extremely hardwearing ball & angular contact bearings
- Corrosive resistance stainless steel body
- Filled with non-toxic oil
- Can be easily dismantled and repaired

Applications

These prime mover submersible motors are suitable to couple with deepwell submersible pump ends used for

- Residential
- Industrial water supply
- Ponds
- Irrigation
- Sprinkler systems
- Mining
- Fountains
- Pressure boosting units
- CBM (coal bed methane)
- Gardens

In view of continuous developments, the information / descriptions / specifications / illustrations are subject to change without notice.

OIL FILLED SUBMERSIBLE MOTORS

Nominal Diameter : **4"**

"L" Series

Deepstar

Specifications

Nominal Dia	4" (100mm)
Maximum Outer Diameter	3.74"
Power Range	0.5 HP to 3 HP - Single Phase
	0.5 HP to 10 HP - Three Phase
Speed	3450 rpm
Version	Single Phase - 110 V & 220 V, 60 Hz, A.C Supply
	Three Phase - 220 V, 380 V & 460 V, 60 Hz, A.C Supply
Class of Insulation	F
Degree of Protection	IP 68
Direction of Rotation	CCW - Single Phase
	Electrically Reversible - Three Phase
Type of Duty	S1 (Continuous)
Down Thrust Load	0.5 HP to 1 HP - 337 lbs
	1.5 HP to 4 HP - 562 lbs
	5 HP to 10 HP - 1011 lbs
Minimum Cooling Flow Along the Motor	0.5 ft/sec
Maximum Liquid Temperature	91.4°F
Maximum Immersion Depth	150 m
Starts per Hour	30 Times
Shaft Type	Splined as per NEMA Standard
Mounting Standard	NEMA Standard
Method of Starting	Single Phase - Permanent Split Capacitor (PSC)
	Three Phase - Direct On Line (DOL)
Cable Lead out	3 Wire Permanent Type TPE/EPDM Rubber Flat Cable



Type - A

Materials of Construction

Part Name	Type - A
Outer Shell	SS - 304
Motor Base	SS - 304
Shaft Extension	SS - 420
'O' Ring	High Nitrile Rubber
Mechanical Seal	Carbon / Ceramic
Diaphragm	High Nitrile Rubber
Cable	TPE / EPDM

OIL FILLED SUBMERSIBLE MOTORS

Nominal Diameter : 4"

"L" Series

Deepstar

Exploded View

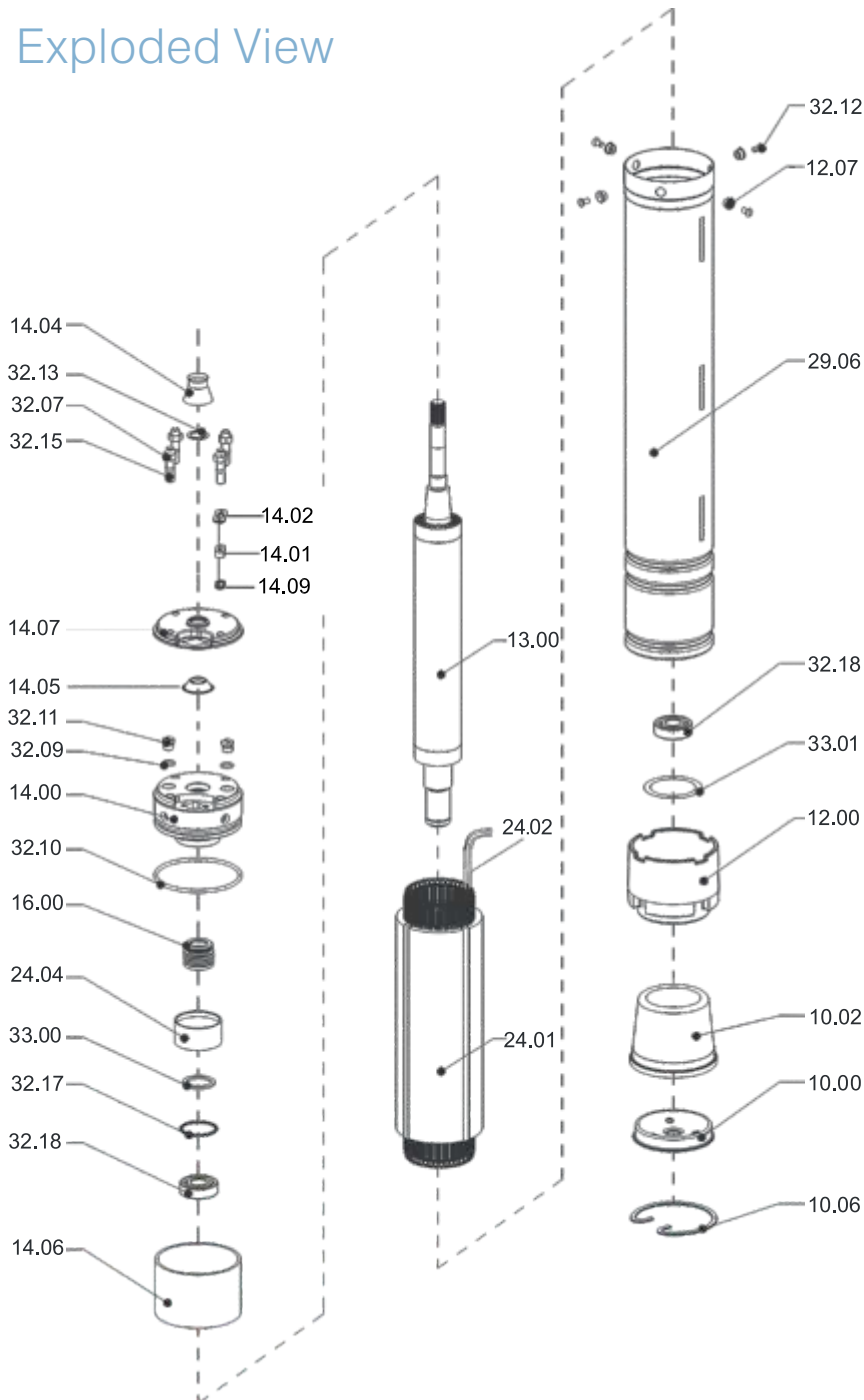

Part No.	Part Name
10.00	Motor base
10.02	Diaphragm
10.06	Snap ring
12.00	Lower housing
12.07	Guide bush
13.00	Rotor
14.00	Upper Housing
14.01	Cable Grommet
14.02	Grommet locking plate
14.04	Rubber sand guard
14.05	Sand guard
14.06	Insulation paper
14.07	Upper housing shell
14.09	Grommet washer
16.00	Mechanical seal
24.01	Wound stator
24.02	Lead out cable
24.04	Winding guard
29.06	Outer shell
32.07	Nut
32.09	O-Ring
32.10	O-Ring (Upper housing)
32.11	Drain plug
32.12	Screw
32.13	Sand guard washer
32.15	Stud
32.16	Washer
32.17	Wave washer
32.18	Bearing
33.00	Seal washer
33.01	Adjustment washer

In view of continuous developments, the information / descriptions / specifications / illustrations are subject to change without notice.

OIL FILLED SUBMERSIBLE MOTORS

Nominal Diameter : 4"

"L" Series

Deepstar

110V, SINGLE PHASE

ELECTRICAL & DIMENSIONAL DATA

Models	kW	HP	S.F.	PF Cosφ	EFF.%	Capacitor MFD		Amps		Max Down Thrust load (lbs)	Height H1		Nett Weight		Cable Size (sq.mm)
						Starting	Running	F.L	Starting		mm	Inches	kg	lbs	
L4A-10-3A	0.75	1	1.5	0.98	65	-	60	12.9	46	337	381	15	8	17.6	1.5
L4A-15-3A	1.1	1.5	1.4	0.98	67	-	80	14.9	58	337	399	15.7	9	19.8	1.5

220V, SINGLE PHASE

ELECTRICAL & DIMENSIONAL DATA

Models	kW	HP	S.F.	PF Cosφ	EFF.%	Capacitor MFD		Amps		Max Down Thrust load (lbs)	Height H1		Nett Weight		Cable Size (sq.mm)
						Starting	Running	F.L	Starting		mm	Inches	kg	lbs	
L4A-05-3D	0.37	0.5	1.6	0.90	48	80-100	15	5.5	22.5	337	361	14.2	7.3	16.1	1.5
L4A-07-3D	0.55	0.75	1.5	0.94	53	80-100	20	6.3	28	337	381	15	8.1	17.9	1.5
L4A-10-3D	0.75	1	1.4	0.93	54	80-100	25	7.6	36	337	399	15.7	9.2	20.3	1.5
L4A-15-3D	1.1	1.5	1.3	0.96	58	100-120	35	9.4	46	562	429	16.9	10.4	22.9	1.5
L4A-20-3D	1.5	2	1.25	0.97	63	120-150	45	12	59	562	480	18.9	12.2	26.9	2
L4A-30-3D	2.2	3	1.15	0.98	69	200-250	50	15.6	90	562	521	20.5	14.4	31.8	2.3

220V, THREE PHASE

ELECTRICAL & DIMENSIONAL DATA

Model	kW	HP	S.F.	Current (Amps)		Eff. (%)	PF Cosφ	Max Down Thrust Load	Height H1		Nett Weight		Cable size (Sq.mm)
				F. L	Starting				mm	Inches	kg	lbs	
L4A-05-4D	0.37	0.5	1.6	2	10	62	0.7	337	409	16.1	7.8	17.2	1.5
L4A-07-4D	0.55	0.75	1.5	3.2	16	65	0.71	337	409	16.1	7.8	17.2	1.5
L4A-10-4D	0.75	1	1.4	4.4	20.0	70	0.72	337	429	16.9	8.8	19.4	1.5
L4A-15-4D	1.1	1.5	1.3	6.5	28.0	71	0.7	562	450	17.7	9.6	21.2	1.5
L4A-20-4D	1.5	2	1.25	7.6	34	72	0.7	562	480	18.9	11.4	25.1	1.5
L4A-30-4D	2.2	3	1.15	10.5	45	75	0.72	562	541	21.3	13.8	30.4	1.5
L4A-40-4D	3	4	1.15	14.2	63	76	0.76	562	602	23.7	18.1	39.9	1.5
L4A-50-4D	3.7	5	1.15	16.2	71	77	0.76	1011	650	25.6	20.1	44.3	2
L4A-55-4D	4	5.5	1.15	18	82	78	0.76	1011	650	25.6	20.1	44.3	2
L4A-75-4D	5.5	7.5	1.15	23.5	104	78	0.78	1011	762	30	26.2	57.8	2.3
L4A-100-4D	7.5	10	1.15	31.5	140	80	0.86	1011	879	34.6	32.6	71.8	2.3

380V, THREE PHASE

ELECTRICAL & DIMENSIONAL DATA

Model	kW	HP	S.F.	Current (Amps)		Eff. (%)	PF Cosφ	Max Down Thrust Load	Height H1		Nett Weight		Cable size (Sq.mm)
				F. L	Starting				mm	Inches	kg	lbs	
L4A-05-4I	0.37	0.5	1.6	1.3	6.5	62	0.7	337	409	16.1	7.8	17.2	1.5
L4A-07-4I	0.55	0.75	1.5	2	11	65	0.71	337	409	16.1	7.8	17.2	1.5
L4A-10-4I	0.75	1	1.4	2.6	14	70	0.72	337	429	16.9	8.8	19.4	1.5
L4A-15-4I	1.1	1.5	1.3	3.6	20	71	0.7	562	450	17.7	9.6	21.2	1.5
L4A-20-4I	1.5	2	1.25	4.9	25	72	0.7	562	480	18.9	11.4	25.1	1.5
L4A-30-4I	2.2	3	1.15	6	30	75	0.72	562	541	21.3	13.8	30.4	1.5
L4A-40-4I	3	4	1.15	8.2	37	76	0.76	562	602	23.7	18.1	39.9	2
L4A-50-4I	3.7	5	1.15	9.3	42	77	0.76	1011	650	25.6	20.1	44.3	2
L4A-55-4I	4	5.5	1.15	10.4	47	78	0.76	1011	650	25.6	20.1	44.3	2
L4A-75-4I	5.5	7.5	1.15	13.7	65	78	0.78	1011	762	30	26.2	57.8	2.3
L4A-100-4I	7.5	10	1.15	18.2	102	80	0.86	1011	879	34.6	32.6	71.8	2.3

460V, THREE PHASE

ELECTRICAL & DIMENSIONAL DATA

Model	kW	HP	S.F.	Current (Amps)		Eff. (%)	PF Cosφ	Max Down Thrust Load	Height H1		Nett Weight		Cable size (Sq.mm)
				F. L	Starting				mm	Inches	kg	lbs	
L4A-05-4M	0.37	0.5	1.6	1.1	5.5	62	0.76	337	409	16.1	7.8	17.2	1.5
L4A-07-4M	0.55	0.75	1.5	1.6	8	66	0.75	337	409	16.1	7.8	17.2	1.5
L4A-10-4M	0.75	1	1.4	2	10	70	0.75	337	429	16.9	8.8	19.4	1.5
L4A-15-4M	1.1	1.5	1.3	2.8	14	72	0.74	562	450	17.7	9.6	21.2	1.5
L4A-20-4M	1.5	2	1.25	3.8	19	74	0.73	562	480	18.9	11.4	25.1	2
L4A-30-4M	2.2	3	1.15	5.5	26	74	0.74	562	541	21.3	13.8	30.4	2.3
L4A-40-4M	3	4	1.15	6.9	34	76	0.74	562	602	23.7	18.1	39.9	2.3
L4A-50-4M	3.7	5	1.15	8.7	43	75	0.77	1011	650	25.6	20.1	44.3	2.3
L4A-55-4M	4	5.5	1.15	10	50	76	0.78	1011	650	25.6	20.1	44.3	2.3
L4A-75-4M	5.5	7.5	1.15	12.8	65	78	0.78	1011	762	30	26.2	57.8	2.3

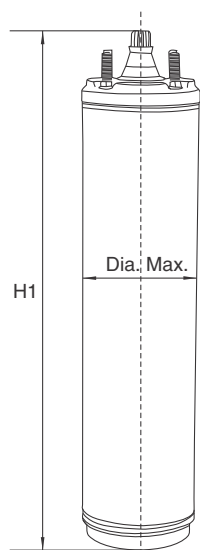

Splined shaft 14 Teeth - module 1.5875 Pressure angle 30° A.N.S.I.B - 92 - 1 - 1970 Coupling Class 5

RESIN FILLED ENCAPSULATED SUBMERSIBLE MOTORS

Nominal Diameter : **4" & 6"**

"R" Series

Description

These motors are hermetically sealed, encapsulated and water lubricated type with removable cable lead out. The stator windings are of enameled copper wire and the wound stator is mounted in a stainless steel shell and is completely protected by a stainless steel cylinder and stator room is pre-filled with resin. The resin filled in the space between the stator & the stainless steel cylinder dissipates heat quickly resulting in longer motor life. Except stator, other portions of the motor is pre-filled with deionised water containing propylene glycol (anti-freeze agent) which serves as coolant & lubricant for rotor, bushes and thrust bearing. Dynamically balanced rotors of these motors maintain uniform clearance thereby giving better efficiency and increase the life cycle of the water lubricated bush bearings. Specially designed high performance thrust bearings are used that can withstand high axial thrust loads and upthrust loads with minimum wear and tear.

The unique design of thrust bearings creates a wedge of water between the shoe and the disc and thereby providing better water lubrication and increases the life cycle of the thrust bearings. Pressure equalizing rubber diaphragm is provided to guard the pressure and volume variations due to thermal expansion of the water inside the motor. Motor sealing are made by means of 'O' rings. Shaft seals and sand guard prevents ingress of well water, sand and fiber particles into the motor. Care should be taken to ensure that the motor does not run when it is not submerged in the water. To prevent the motor dry running, install water level monitor / dry run preventor. The motor needs a constant flow of water past it's body to keep it at correct operating temperature. Ideally, the motor should be set just below the level at which water enters the bore well. When this level is not ascertained, fit a "flow inducer sleeve" over the pumpset to ensure adequate cooling. It is mandatory to install C.R.I. Control box for all single phase 3 wire motors. All 3 Ph motors require an adequate motor protection control panel. Mounting dimensions of motors are in accordance with NEMA standards.

Features

- Corrosive resistant stainless steel body.
- Specially designed thrust bearing to withstand high axial thrust loads.
- Low watt loss silicon steel laminations for better starting torque.
- Higher power factor resulting in lesser power consumption.
- Better heat dissipation for prolonged life cycle.
- All single phase two wire motors are supplied with in-built permanent split capacitor.
- Optional : All single phase models are also available with lightening arrester.

Applications

These prime mover submersible motors are suitable to couple with deepwell submersible pumps used for :

- Residential • Irrigation • Pressure boosting units
- Fountains • Gardens • Sprinkler System
- Industrial water supply • Mining • Oil & Gas • De-watering

In view of continuous developments, the information / descriptions / specifications / illustrations are subject to change without notice.

RESIN FILLED ENCAPSULATED SUBMERSIBLE MOTORS

Nominal Diameter : **4"**

"R" Series

Specifications

Nominal Dia	4" (100mm)
Maximum Outer Diameter	3.74"
Power Range	0.5 HP to 1.5 HP - Single Phase 2 Wire
	0.5 HP to 5 HP - Three Phase 3 Wire
	0.5 HP to 10 HP - Three Phase 3 Wire
Speed	3450 rpm
Version	Single Phase - 110 V, 220 V, 60 Hz, A.C Supply
	Three Phase - 220 V, 380 V & 460 V, 60 Hz, A.C Supply
Class of Insulation	B
Degree of Protection	IP 68
Direction of Rotation	CCW - Single Phase
	Electrically Reversible - Three Phase
Type of Duty	S1 (Continuous)
Down Thrust Load	0.5 HP to 0.75 HP - 300 lbs
	1 HP to 2 HP - 650 lbs
	3 HP to 10 HP - 1500 lbs
Minimum Cooling Flow Along the Motor	0.25 ft/sec
Maximum Liquid Temperature	91.4°F
Starts per Hour	20 Times
Shaft Type	Splined as per NEMA Standard
Mounting Standard	NEMA Standard
Method of Starting	Single Phase-3 Wire - Capacitor Start Capacitor Run (CSCR)
	Single Phase-2 Wire - Permanent Split Capacitor (PSC)
	Three Phase - Direct On Line (DOL)
Cable Lead out	2 & 3 Wire Removable Type TPE Flat Cable



Materials of Construction

Part Name	Type - A
Housings Shell	SS - 304
Stator Shell	SS - 304
Thrust Pad	Carbon Graphite
Thrust Bearing	SS - 420
'O' Ring	Nitrile Rubber (NBR)
Diaphragm	Nitrile Rubber (NBR)
Motor Base	SS - 304
Cable	TPE

RESIN FILLED ENCAPSULATED SUBMERSIBLE MOTORS

Nominal Diameter : **4"**

"R" Series

(0.5 to 3HP)
(*2 wire & 3 wire)

Exploded view

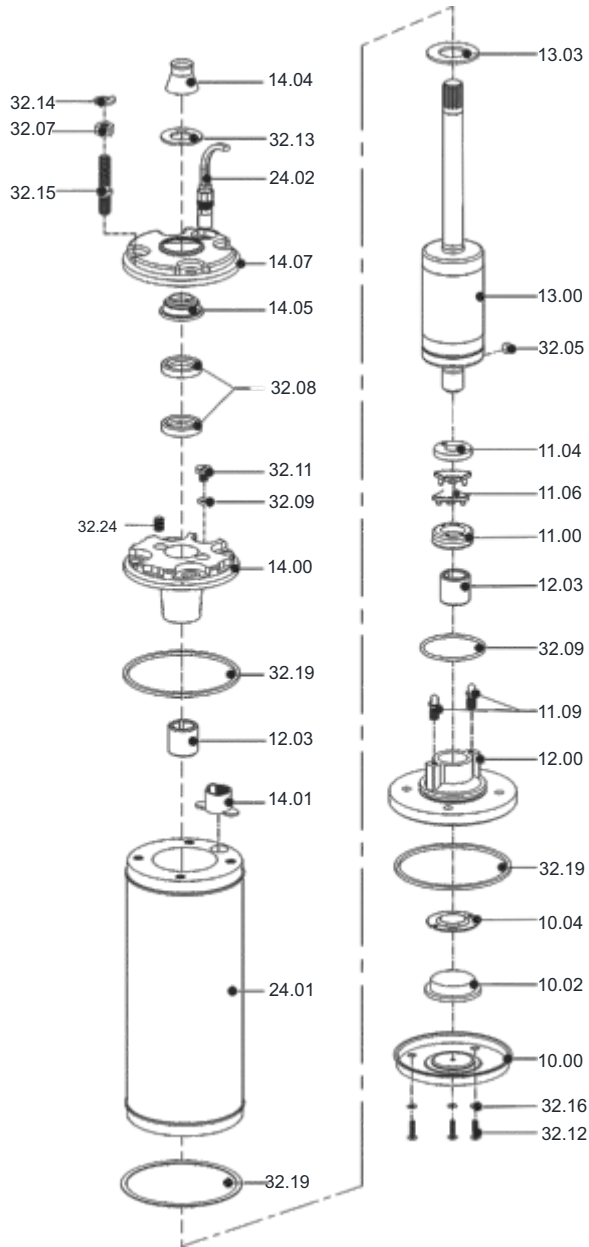

Part No.	Part Name
10.00	Motor base
10.02	Diaphragm
10.04	Diaphragm guide plate
11.00	Thrust Base
11.04	Thrust Pad
11.06	Thrust segment
11.09	Rocker screw
12.00	Lower housing
12.03	Bush
13.00	Rotor
13.03	Upthrust washer
14.00	Upper housing
14.01	Cable grommet clamp
14.04	Rubber sand guard
14.05	Sand guard
14.07	Upper housing shell
21.01	Wound stator
24.02	Lead out cable
32.05	Pad key
32.07	Nut
32.08	Oil seal
32.09	O - Ring
32.11	Drain Plug
32.12	Screw
32.13	Sand guard washer
32.14	Spring washer
32.15	Stud
32.16	Washer
32.19	Gasket
32.24	Vent plug

* 2 wire motor's stator is in-built with permanent split capacitor

In view of continuous developments, the information / descriptions / specifications / illustrations are subject to change without notice.

RESIN FILLED ENCAPSULATED SUBMERSIBLE MOTORS

Nominal Diameter : **4"**

"R" Series
(4HP and above)

Exploded view

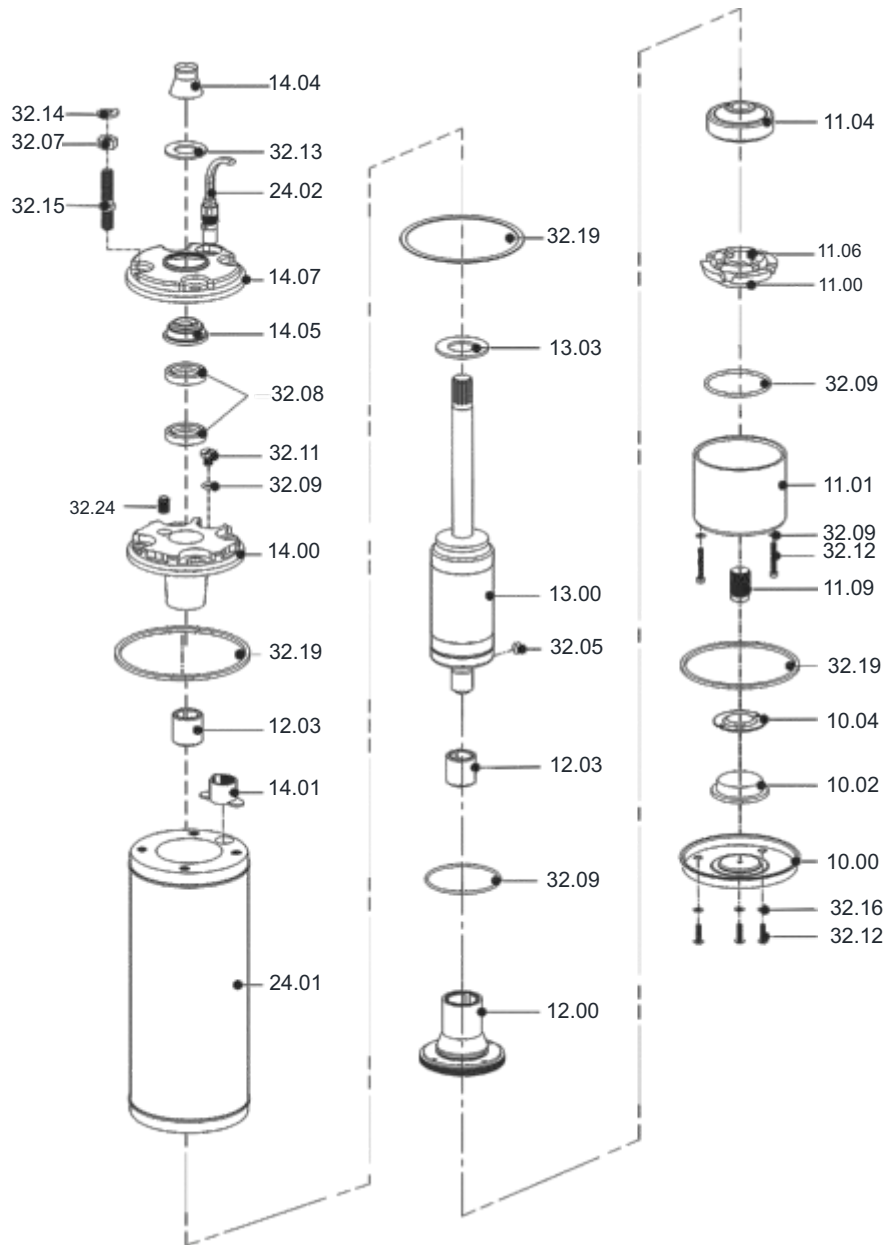

Part No.	Part Name
10.00	Motor base
10.02	Diaphragm
10.04	Diaphragm guide plate
11.00	Thrust Base
11.01	Thrust base housing
11.04	Thrust Pad
11.06	Thrust segment
11.09	Rocker screw
12.00	Lower housing
12.03	Bush
13.00	Rotor
13.03	Upthrust washer
14.00	Upper housing
14.01	Cable grommet clamp
14.04	Rubber sand guard
14.07	Upper housing shell
24.01	Wound stator
24.02	Lead out cable
32.05	Pad key
32.07	Nut
32.08	Oil seal
32.09	O - ring
32.11	Drain plug
32.12	Screw
32.13	Sand guard washer
32.14	Spring washer
32.15	Stud
32.16	Washer
32.19	Gasket
32.24	Vent plug

RESIN FILLED ENCAPSULATED SUBMERSIBLE MOTORS

Nominal Diameter : 4"

"R" Series

110 V & 220V, SINGLE PHASE, 2 WIRE MOTORS

TECHNICAL & ELECTRICAL DATA

Models	Voltage	HP	S.F.	Rated (F.L.)		Maximum (S.F.)		Eff. %		P.F. %		Locked Rotor Amps	Max. Down Thrust Load (lbs)	Capacitor Value µf
				Amps	Watts	Amps	Watts	S.F.	F.L.	S.F.	F.L.			
R4AS-05-2A	110V	0.5	1.6	7.1	753	9.2	980	60	50	97	97	32	300	50
R4AS-07-2A	110V	0.75	1.5	10	1100	12.7	1395	61	52	99	99	43	300	60
R4AS-10-2A	110V	1	1.4	12.1	1313	15	1640	64	57	98	99	55	650	80
R4AS-05-2D	220V	0.5	1.6	3.4	730	4.3	960	62	51	97	92	18	300	25
R4AS-07-2D	220V	0.75	1.5	4.7	998	5.8	1300	61	56	95	92	25	300	30
R4AS-10-2D	220V	1	1.4	6.2	1306	7.5	1650	63	57	95	91	33	650	35
R4AS-15-2D	220V	1.5	1.3	9	1931	10.5	2300	65	62	97	95	45	650	45

110 V & 220V, SINGLE PHASE, 3 WIRE MOTORS

TECHNICAL & ELECTRICAL DATA

Models	Voltage	HP	S.F.	Rated (F.L.)		Maximum (S.F.)		Eff. %		P.F. %		Locked Rotor Amps	Max. Down Thrust Load (lbs)	Capacitor Value µf	
				Amps	Watts	Amps	Watts	S.F.	F.L.	S.F.	F.L.			Start	Run
R4AS-05-3A	110V	0.5	1.6	8.5	760	11.5	1120	54	50	88	82	36	300	125	20
R4AS-07-3A	110V	0.75	1.5	10.3	1027	14.5	1450	57	55	91	90	46	300	125	30
R4AS-10-3A	110V	1	1.4	12	1186	16	1620	64	63	93	90	58	650	150	40
R4AS-05-3D	220V	0.5	1.6	4.2	796	5.5	1120	54	50	76	62	23	300	60	10
R4AS-07-3D	220V	0.75	1.5	5.3	1141	6.9	1550	61	56	75	64	32	300	60	15
R4AS-10-3D	220V	1	1.4	6.4	1412	8.3	1825	63	57	73	62	39	650	100	20
R4AS-15-3D	220V	1.5	1.3	8.8	1994	11.5	2390	65	62	86	82	46	650	100	20
R4AS-20-3D	220V	2	1.15	10.7	2236	12.3	2453	70	66	93	92	54	650	125	30
R4AS-30-3D	220V	3	1.15	15.5	3530	18.5	4035	69	69	97	97	85	1500	150	45
R4AS-50-3D	220V	5	1.15	25.5	5770	31	6634	69	69	98	98	120	1500	250	80

220V, THREE PHASE, 3 WIRE MOTORS

TECHNICAL & ELECTRICAL DATA

Models	HP	S.F.	Rated (F.L.)		Maximum (S.F.)		Eff. %		P.F. %		Locked Rotor Amps	Max. Down Thrust Load (lbs)
			Amps	Watts	Amps	Watts	S.F.	F.L.	S.F.	F.L.		
R4A-05-4D	0.5	1.6	2.5	590	3	870	68	63	76	62	15.5	300
R4A-07-4D	0.75	1.5	3.2	825	3.9	1170	70	68	78	66	20	300
R4A-10-4D	1	1.4	4	1100	4.8	1460	71	71	80	70	26.9	650
R4A-15-4D	1.5	1.3	5	1490	6	1910	74	74	83	76	34	650
R4A-20-4D	2	1.25	6.8	2180	8.2	2720	73	73	86	80	45	650
R4A-30-4D	3	1.15	9.5	3010	11	3450	74	74	81	78	62	1500
R4A-50-4D	5	1.15	16	5100	18	5830	73	73	84	81	105	1500
R4A-55-4D	5.5	1.15	18.2	5650	20.6	6540	73	73	80	78	115	1500
R4A-75-4D	7.5	1.15	23	7400	26.8	8460	75	75	83	81	165	1500
R4A-100-4D	10	1.15	31	10000	35	11450	75	74	88	86	230	1500

In view of continuous developments, the information / descriptions / specifications / illustrations are subject to change without notice.

RESIN FILLED ENCAPSULATED SUBMERSIBLE MOTORS

Nominal Diameter : 4"

"R" Series

380V, THREE PHASE, 3 WIRE MOTORS

TECHNICAL & ELECTRICAL DATA

Models	HP	S.F.	Rated (F.L.)		Maximum (S.F.)		Eff. %		P.F. %		Locked Rotor Amps	Max. Down Thrust Load (lbs)
			Amps	Watts	Amps	Watts	S.F.	F.L.	S.F.	F.L.		
R4A-05-4I	0.5	1.6	1.5	590	2.2	870	68	63	76	62	9.7	300
R4A-07-4I	0.75	1.5	2	825	2.6	1170	70	68	78	66	12	300
R4A-10-4I	1	1.4	2.4	1100	2.9	1460	71	71	80	70	16.5	650
R4A-15-4I	1.5	1.3	3	1490	3.7	1910	74	74	83	76	20	650
R4A-20-4I	2	1.25	4.1	2180	5	2720	73	73	86	80	28.5	650
R4A-30-4I	3	1.15	5.9	3010	6.8	3450	74	74	81	78	38	1500
R4A-50-4I	5	1.15	9.8	5100	11	5830	73	73	84	81	65	1500
R4A-55-4I	5.5	1.15	11	5650	12.2	6450	73	73	80	78	70	1500
R4A-75-4I	7.5	1.15	14	7400	16	8460	75	75	83	81	98	1500
R4A-100-4I	10	1.15	19.5	10000	21.2	11500	75	74	88	86	140	1500

460V, THREE PHASE, 3 WIRE MOTORS

TECHNICAL & ELECTRICAL DATA

Models	HP	S.F.	Rated (F.L.)		Maximum (S.F.)		Eff. %		P.F. %		Locked Rotor Amps	Max. Down Thrust Load (lbs)
			Amps	Watts	Amps	Watts	S.F.	F.L.	S.F.	F.L.		
R4A-05-4M	0.5	1.6	1.3	590	1.6	870	68	63	76	62	7.5	300
R4A-07-4M	0.75	1.5	1.7	825	2	1170	70	68	78	66	11	300
R4A-10-4M	1	1.4	2	1100	2.5	1460	71	71	80	70	13.5	650
R4A-15-4M	1.5	1.3	2.5	1490	3.2	1910	74	74	83	76	16.8	650
R4A-20-4M	2	1.25	3.4	2180	4.2	2720	73	73	86	80	23.5	650
R4A-30-4M	3	1.15	4.9	3010	5.6	3450	74	74	81	78	32	1500
R4A-50-4M	5	1.15	8	5100	9	5830	73	73	84	81	55	1500
R4A-55-4M	5.5	1.15	9.3	5650	10.2	6540	73	73	80	78	60	1500
R4A-75-4M	7.5	1.15	11.5	7400	13.5	8460	75	75	83	81	80	1500
R4A-100-4M	10	1.15	16	10000	17.4	11500	75	74	88	86	115	1500

SINGLE PHASE 2 & 3 WIRE MOTORS

DIMENSIONS & WEIGHT DATA

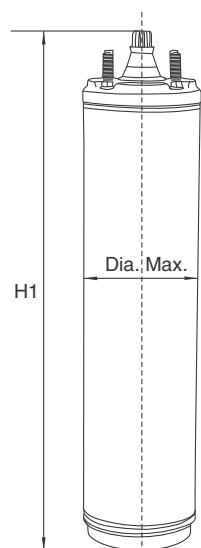

Models		HP	Leadout Cable Size (Sq.mm)	Height H1				Nett Weight (Approx.)			
2 wire	3 wire			2 wire		3 wire		2 wire		3 wire	
				mm	Inch	mm	Inch	kg	lbs	kg	lbs
R4AS-05-2	R4AS-05-3	0.5	2	292	11.5	241	9.5	44	19.8	39	17.8
R4AS-07-2	R4AS-07-3	0.75	2	320	12.6	270	10.6	50	22.7	44	19.8
R4AS-10-2	R4AS-10-3	1	2	348	13.7	297	11.7	55	24.9	50	22.9
R4AS-15-2	R4AS-15-3	1.5	2	396	15.6	345	13.6	68	30.9	64	29.1
NA	R4AS-20-3	2	2	-	-	383	15.1	-	-	71	32.2
NA	R4AS-30-3	3	2	-	-	531	20.9	-	-	112	50.7
NA	R4AS-50-3	5	2	-	-	686	27	-	-	145	66.1

THREE PHASE 3 WIRE MOTORS

DIMENSIONS & WEIGHT DATA

Models	HP	Leadout Cable Size (Sq.mm)	Height H1		Nett Weight (Approx.)	
			mm	Inch	kg	lbs
R4A-05-4	0.5	2	241	9.5	39	17.8
R4A-07-4	0.75	2	270	10.6	44	19.8
R4A-10-4	1	2	297	11.7	50	22.9
R4A-15-4	1.5	2	297	11.7	50	22.9
R4A-20-4	2	2	345	13.6	64	29.1
R4A-30-4	3	2	455	17.9	88	40.1
R4A-50-4	5	2	530	20.9	112	50.7
R4A-55-4	5.5	2	556	21.9	116	52.9
R4A-75-4	7.5	2	686	27	145	66.1
R4A-100-4	10	2	757	29.8	165	75

Splined shaft 14 Teeth - module
1.5875 Pressure angle 30°
A.N.S.I.B - 92 - 1 - 1970
Coupling Class 5

In view of continuous developments, the information / descriptions / specifications / illustrations are subject to change without notice.

RESIN FILLED ENCAPSULATED SUBMERSIBLE MOTORS

Nominal Diameter : **6"**

"R" Series

Specifications

Nominal Dia	6" (150mm)
Maximum Outer Diameter	5.62"
Power Range	5 HP to 60 HP - Three Phase
Speed	3450 rpm
Version	Three Phase - 230 V, 380 V & 460 V, 60 Hz, A.C Supply
Class of Insulation	F
Degree of Protection	IP 68
Direction of Rotation	Electrically Reversible
Type of Duty	S1 (Continuous)
Down Thrust Load	5 HP to 30 HP - 3485 lbs
	40 HP to 60 HP - 6182 lbs
Minimum Cooling Flow Along the Motor	0.52 ft/sec
Maximum Liquid Temperature	5 HP to 40 HP - 86°F, 50 HP & 60 HP - 122°F
Starts per Hour	20 Times
Shaft Type	Splined as per NEMA Standard
Mounting Standard	NEMA Standard
Method of Starting	Three Phase - Direct On Line (DOL)
	Three Phase - Star Delta (SD)
Cable Lead out	3 Wire Removable Type TPE Flat Cable



Materials of Construction

Part Name	Type - A
Housings Shell	SS - 304
Stator Shell	SS - 304
Thrust Pad	Carbon Graphite
Thrust Bearing	SS - 420
'O' Ring	Nitrile Rubber (NBR)
Diaphragm	Nitrile Rubber (NBR)
Motor Base	SS - 304
Cable	TPE

RESIN FILLED ENCAPSULATED SUBMERSIBLE MOTORS

Nominal Diameter : **6"****"R" Series**

230V, THREE PHASE

TECHNICAL & ELECTRICAL DATA

Models	HP	S.F.	Rated (F.L.)		Maximum (S.F.)		Eff. %		P.F. %		Locked Rotor Amps	Max. Down Thrust Load (lbs)
			Amps	Watts	Amps	Watts	S.F.	F.L.	S.F.	F.L.		
R6A-55-4E	5	1.15	15	4700	17.6	5400	79	79	79	79	86	3485
R6A-75-4E	7.5	1.15	21.8	7000	24.6	8000	80	80	80	80	130	3485
R6A-100-4E	10	1.15	28.4	9400	32.2	10800	79	79	79	79	172	3485
R6A-150-4E	15	1.15	41.6	13700	47.4	15800	81	81	81	81	266	3485
R6A-200-4E	20	1.15	53.8	18100	60.6	20900	82	82	82	82	362	3485
R6A-225-4E	25	1.15	67	22500	75	25700	83	83	83	83	480	3485
R6A-300-4E	30	1.15	79	26900	90.4	31100	83	83	83	83	568	3485

380V, THREE PHASE

TECHNICAL & ELECTRICAL DATA

Models	HP	S.F.	Rated (F.L.)		Maximum (S.F.)		Eff. %		P.F. %		Locked Rotor Amps	Max. Down Thrust Load (lbs)
			Amps	Watts	Amps	Watts	S.F.	F.L.	S.F.	F.L.		
R6A-55-4I	5	1.15	9.1	4700	10.7	5400	79	79	79	79	52	3485
R6A-75-4I	7.5	1.15	13.4	7000	15	8000	80	80	80	80	79	3485
R6A-100-4I	10	1.15	17.6	9400	19.6	10800	79	79	79	79	104	3485
R6A-150-4I	15	1.15	25.8	13700	28.9	15800	81	81	81	81	161	3485
R6A-200-4I	20	1.15	33	18100	37.3	20900	82	82	82	82	219	3485
R6A-225-4I	25	1.15	41	22500	46	25700	83	83	83	83	291	3485
R6A-300-4I	30	1.15	48.8	26900	55.4	31100	83	83	83	83	317	3485
R6A-400-4I	40	1.15	66.5	35600	74.6	42400	83	83	83	83	481	6182
R6A-500-4I	50	1.15	83.5	45100	95	52200	83	83	83	83	501	6182
R6A-600-4I	60	1.15	98.7	53500	111	61700	84	84	84	84	627	6182

460V, THREE PHASE

TECHNICAL & ELECTRICAL DATA

Models	HP	S.F.	Rated (F.L.)		Maximum (S.F.)		Eff. %		P.F. %		Locked Rotor Amps	Max. Down Thrust Load (lbs)
			Amps	Watts	Amps	Watts	S.F.	F.L.	S.F.	F.L.		
R6A-55-4M	5	1.15	7.5	4700	8.8	5400	79	79	79	79	43	3485
R6A-75-4M	7.5	1.15	10.9	7000	12.3	8000	80	80	80	80	65	3485
R6A-100-4M	10	1.15	14.2	9400	16.1	10800	79	79	79	79	86	3485
R6A-150-4M	15	1.15	20.8	13700	23.7	15800	81	81	81	81	133	3485
R6A-200-4M	20	1.15	26.9	18100	30.3	20900	82	82	82	82	181	3485
R6A-225-4M	25	1.15	33.5	22500	37.5	25700	83	83	83	83	240	3485
R6A-300-4M	30	1.15	39.5	26900	45.2	31100	83	83	83	83	284	3485
R6A-400-4M	40	1.15	54.9	35600	61.6	42400	83	83	83	83	397	6182
R6A-500-4M	50	1.15	67.7	45100	77	52200	83	83	83	83	414	6182
R6A-600-4M	60	1.15	80.5	53500	91	61700	84	84	84	84	518	6182

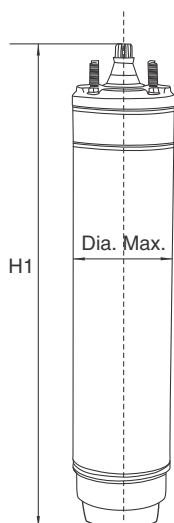

THREE PHASE, 3 WIRE MOTORS

DIMENSIONS & WEIGHT DATA

Models	HP	Height H1		Nett Weight (Approx.)	
		mm	Inches	kg	lbs
R6A-50-4M	5	645	25.4	25.5	56
R6A-75-4M	7.5	579	22.8	22.7	50
R6A-100-4M	10	610	24	24	53
R6A-150-4M	15	676	26.6	26.4	58
R6A-200-4M	20	739	29.1	29	64
R6A-250-4M	25	805	31.7	31.8	70
R6A-300-4M	30	869	34.2	34	75
R6A-400-4M	40	998	39.3	39.5	87
R6A-500-4M	50	1336	52.6	52.7	116
R6A-600-4M	60	1638	64.5	64.5	142

WATER FILLED REWINDABLE SUBMERSIBLE MOTORS

Nominal Diameter : **4", 6", 8", 10" & 12"**

"W" Series

Wellrounder

Description

These motors are eco-friendly, wet type, water filled and rewindable. The stator windings are of water proof synthetic film insulated copper winding wires. It features water lubricated thrust and journal bearings. Motor is pre-filled with clear, cold, pure, fresh, filtered propylene glycon (anti-freez agent) mixed water. Before commissioning, ensure the pre-filled level of water inside the motor. If any loss of volume is noticed, refill with clear, cold, pure, fresh, filtered water, through water filling plugs / valves provided in the upper housing. Where the use of anti-freeze agent mixed water is not be allowed for special applications, these motors can also be filled with clear, cold, pure, fresh, filtered water and operated. Dynamically balanced rotors maintains uniform clearance thereby giving better efficiency and increase the life cycle of the water lubricated bush bearings. Specially designed high performance thrust bearings are used to withstand high axial thrust loads and up thrust loads with minimum wear and tear.

The unique design of thrust bearings create a wedge of water between the shoe and the disc, and thereby providing better water lubrication and increases the life cycle of the thrust bearings. Pressure equalizing rubber diaphragm is provided to balance the pressure and volume variations of the water inside the motor. Motor sealing are made by means of 'O' rings. Shaft seals and sand guard prevents ingress of well water, sand and fiber particles into the motor. Care should betaken to ensure that the motor does not run when it is not submerged in the water, To prevent the motor from dry running, install water level monitor/dry run preventor. The motor needs a constant flow of water passed over it's body to keep it at correct operating temperature. Ideally the motors should be set just above the final yield point of bore well and when the level is not ascertained, fit a "flow inducer pipe" over the pumpset to ensure adequate cooling. It is mandatory to use C.R.I. Control boxes for all motors with adequate protection & control systems. Mounting dimensions of these motors are in accordance with NEMA standard.

Features

- Water cooled Re-windable motor
- Can be easily dismantled and repaired
- High operating efficiency
- Extremely hardwearing and water lubricated bearings
- Specially designed thrust bearing to withstand high axial loads.
- AISI 630 (17.4 PH) motor shaft extension for longer life.

Applications

These prime mover submersible motors are suitable to couple with deepwell submersible pumps used for

- | | | |
|---------------------------|---------------------------|--------------------------|
| ● Residential | ● Pressure boosting units | ● Oil & Gas |
| ● Irrigation | ● Gardens | ● De-watering |
| ● Fountains | ● Sprinkler systems | ● CBM (Coal bed methane) |
| ● Industrial water supply | ● Mining | ● Mining |



In view of continuous developments, the information / descriptions / specifications / illustrations are subject to change without notice.

WATER FILLED REWINDABLE SUBMERSIBLE MOTORS

Nominal Diameter : **4"**

"W" Series
(Upto 2HP)

Wellrounder

Exploded view

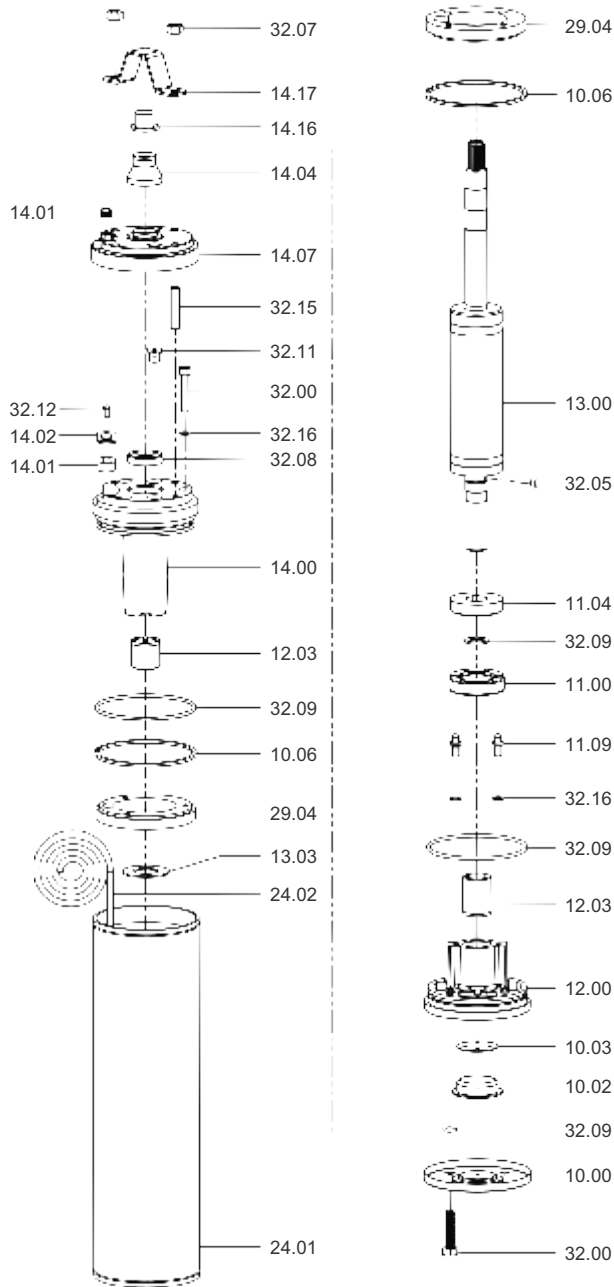

Part No.	Part Name
10.00	Motor Base
10.02	Diaphragm
10.03	Diaphragm Plate
10.06	Snap Ring
11.00	Thrust Base
11.04	Thrust Pad
11.09	Rocker Screw
12.00	Lower Housing
12.03	Bush
13.00	Rotor
13.03	Up Thrust Washer
14.00	Upper Housing
14.01	Cable Grommet
14.02	Grommet Clamp
14.04	Rubber Sand Guard
14.07	Upper Housing Shell
14.16	Motor Cap
14.17	Motor Clamp
24.01	Wound Stator
24.02	Lead Out Cable
29.04	Flange
32.00	Bolt
32.05	Key
32.07	Nut
32.08	Oil Seal
32.09	O Ring
32.11	Drain Plug
32.12	Screw
32.15	Stud
32.16	Washer

WATER FILLED REWINDABLE SUBMERSIBLE MOTORS

Nominal Diameter : 4"

"W" Series

(3HP & Above)

Wellrounder

Exploded view

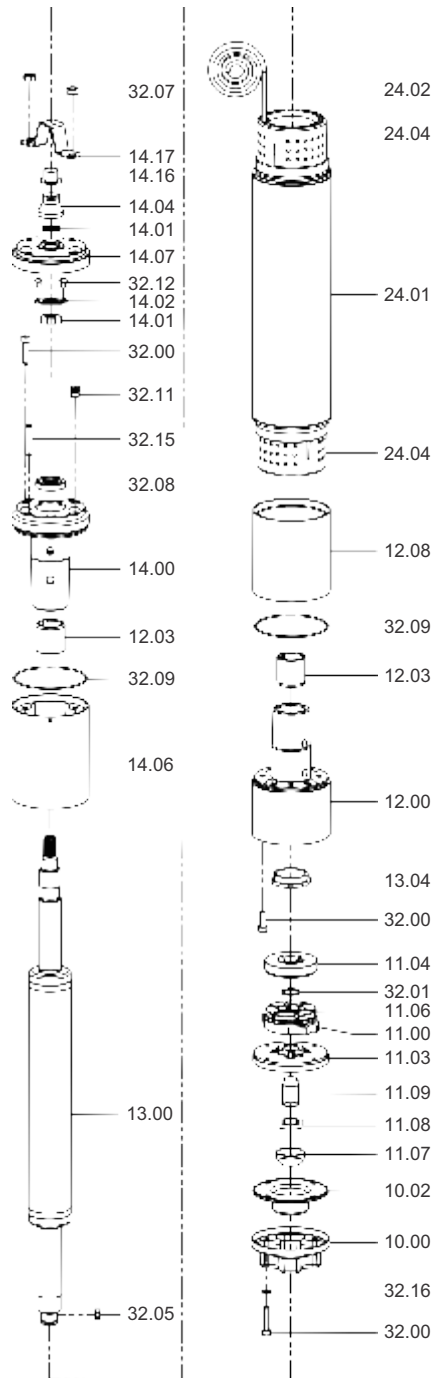

Part No.	Part Name
10.00	Motor Base
10.02	Diaphragm
11.00	Thrust Base
11.03	Thrust Base Plate
11.04	Thrust Pad
11.06	Thrust Segment
11.07	Rocker Screw Cap
11.08	Rocker Screw Nut
11.09	Rocker Screw
12.00	Lower Housing
12.03	Bush
12.08	Lower Pipe
13.00	Rotor
13.04	Counter Thrust Pad
14.00	Upper Housing
14.01	Cable Grommet
14.02	Grommet Clamp
14.04	Rubber Sand Guard
14.06	Upper Pipe
14.07	Upper Housing Shell
14.16	Motor Cap
14.17	Motor Clamp
24.01	Wound Stator
24.02	Lead Out Cable
24.04	Winding Guard
32.00	Bolt
32.01	Circlip
32.05	Key
32.07	Nut
32.08	Oil Seal
32.09	O Ring
32.11	Drain Plug
32.12	Screw
32.15	Stud
32.16	Washer

WATER FILLED REWINDABLE SUBMERSIBLE MOTORS

Nominal Diameter : **6"**

"W" Series

Wellrounder

Exploded view

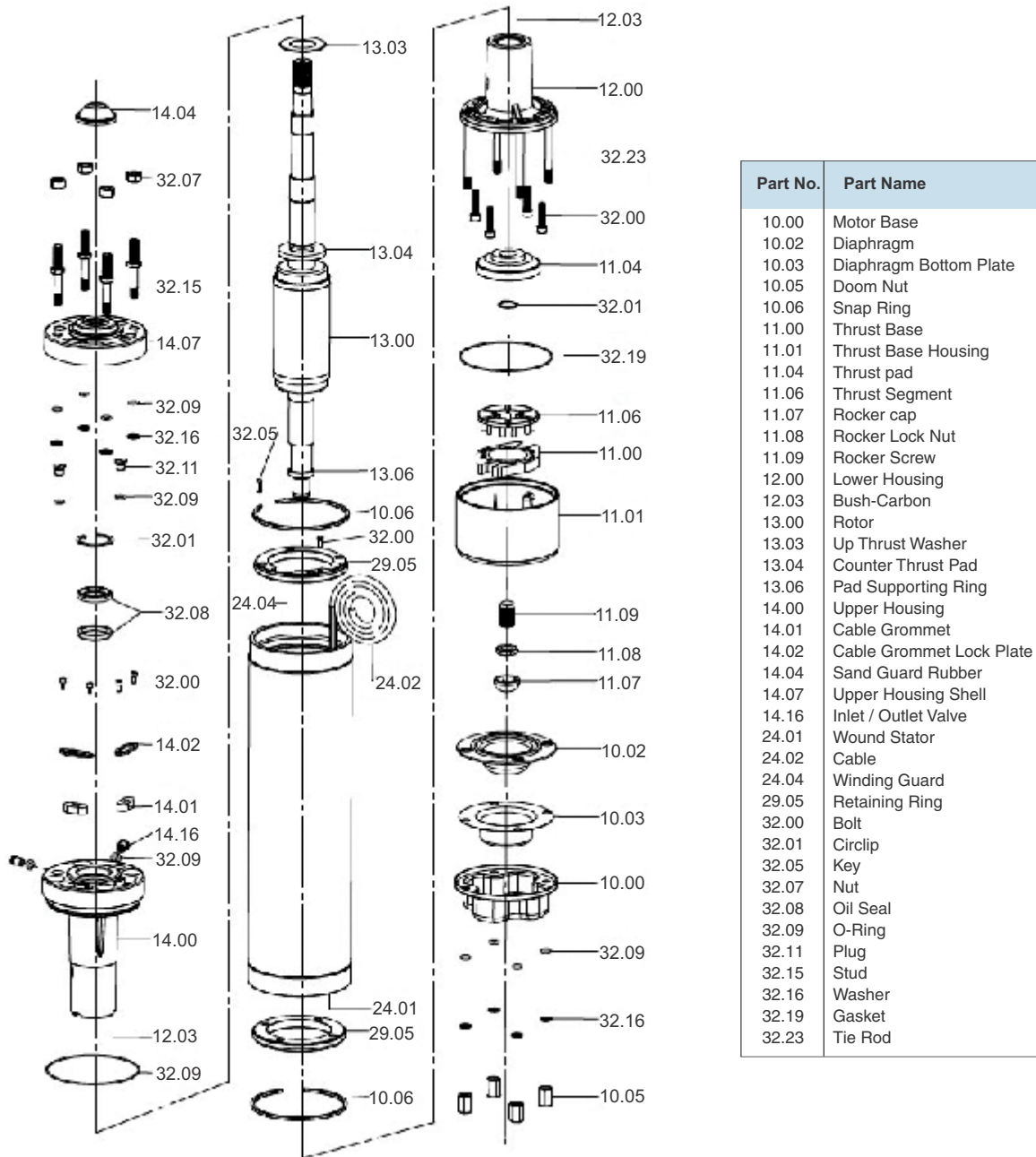

WATER FILLED REWINDABLE SUBMERSIBLE MOTORS

Nominal Diameter : **8"**

"W" Series

Wellrounder

Exploded view

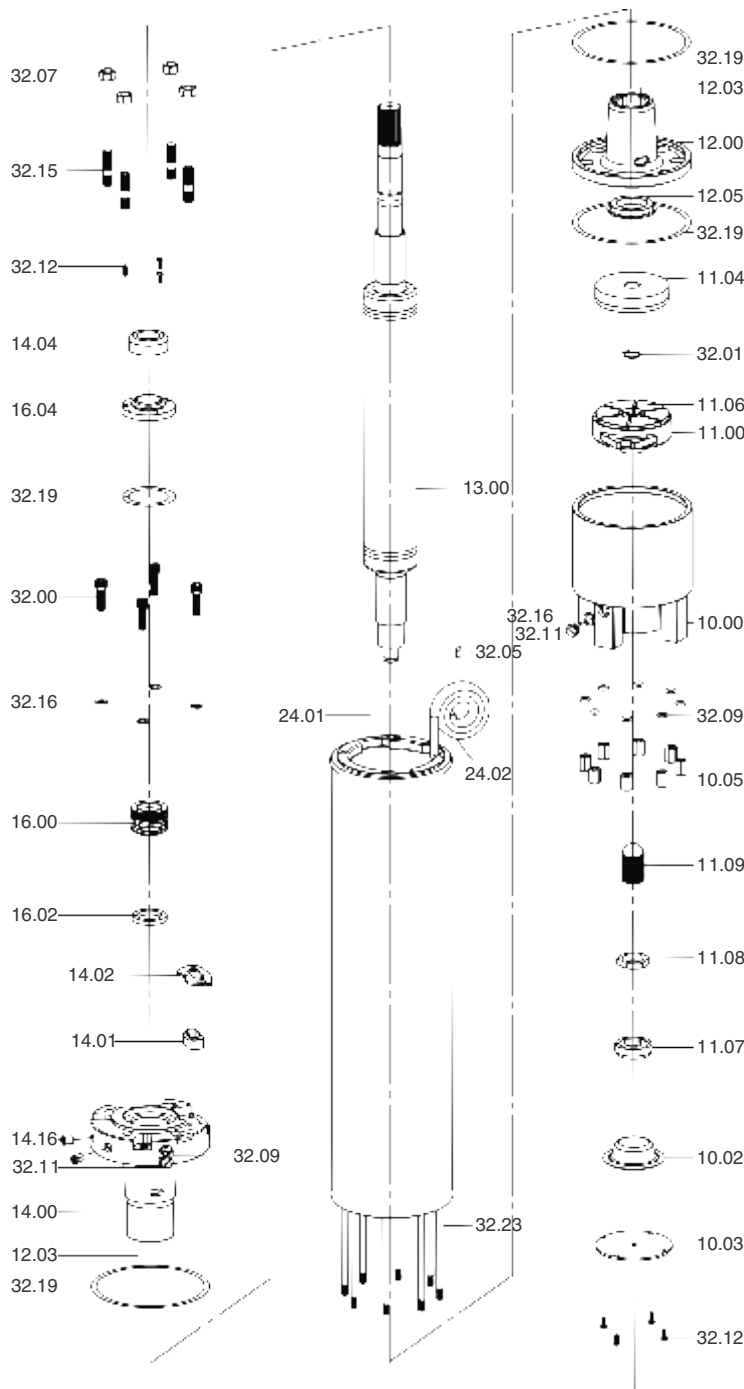

Part No.	Part Name
10.00	Motor Base
10.02	Diaphragm
10.03	Diaphragm Bottom Plate
10.05	Doom nut
11.00	Thrust Base
11.04	Thrust Pad
11.06	Thrust Segment
11.07	Rocker Cap
11.08	Rocker Lock nut
11.09	Rocker Screw
12.00	Lower Housing
12.03	Bush-Carbon
12.05	Counter Thrust Ring
13.00	Rotor
14.00	Upper Housing
14.01	Cable Grommet
14.02	Cable Grommet Lock Plate
14.04	Sand Guard-Rubber
14.16	Inlet / Outlet Valve
16.00	Mechanical Seal
16.02	Mechanical Seal Rest Washer
16.04	Mechanical Seal Guide Plate
24.01	Wound Stator
24.02	Cable
32.00	Bolt
32.01	Circlip
32.05	Key
32.07	Nut
32.09	O-ring
32.11	Plug
32.12	Screw
32.15	Stud
32.16	Washer
32.19	Gasket
32.23	Tie Rod

In view of continuous developments, the information / descriptions / specifications / illustrations are subject to change without notice.

WATER FILLED REWINDABLE SUBMERSIBLE MOTORS

Nominal Diameter : **10"**

"W" Series

Wellrounder

Exploded view

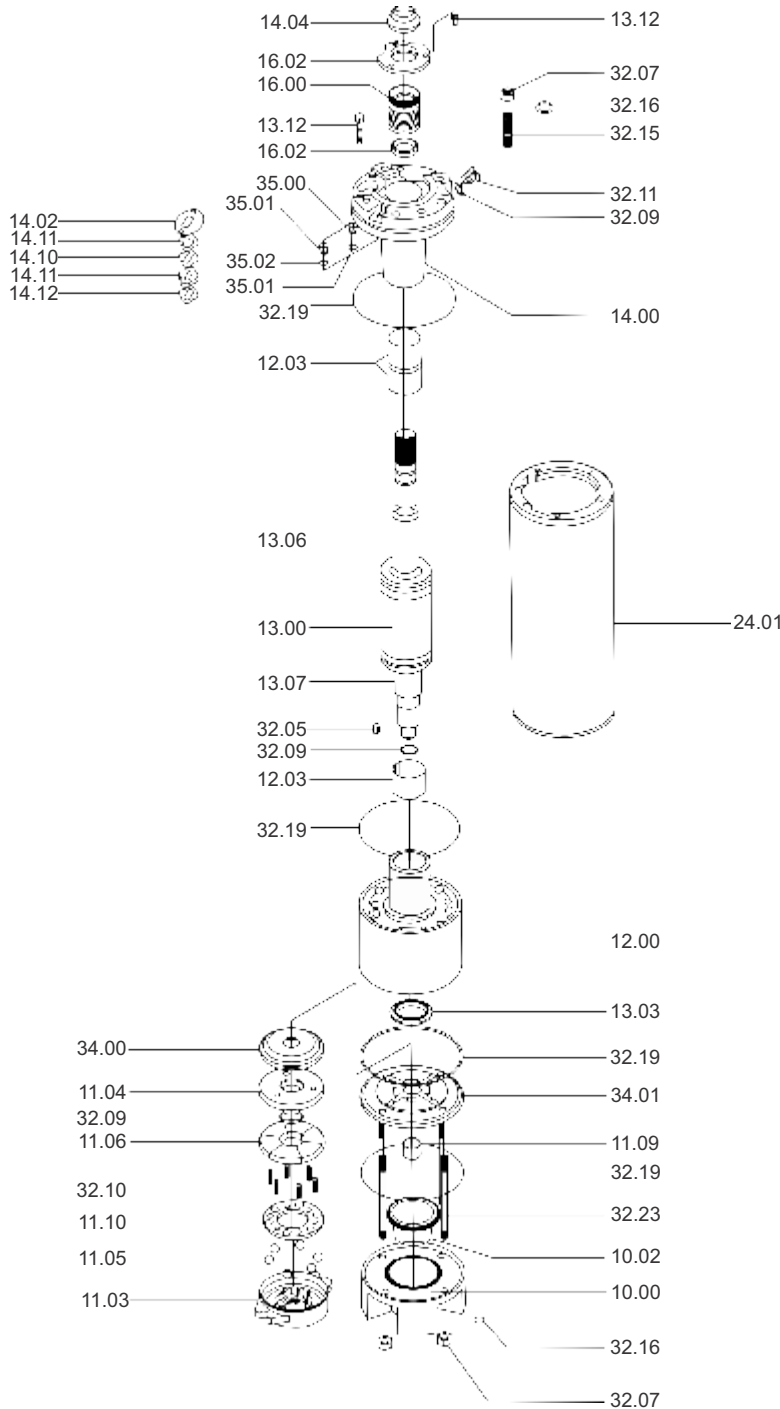

Part No.	Part Name
10.00	Motor Base
10.02	Diaphragm
11.03	Thrust Bearing Bottom
11.04	Thrust Pad
11.05	Ball
11.09	Rocker Screw
12.00	Lower Housing
12.03	Bush
13.00	Rotor
13.03	Upthrust Washer
13.06	Rotor Sleeve
13.07	Rotor Sleeve
14.00	Upper Housing
14.02	Grommat Locking Plate
14.04	Rubber Sand Guard
14.10	Cable clamping Plate
14.11	Cable clamping Plastic
14.12	Cable Clamping Washer
16.00	Mechanical Seal
16.02	Mechanical Seal Clamp Plate
24.01	Wound Stator
32.01	Circlip
32.05	Pad Key
32.07	Nut
32.09	"O" Ring
32.10	Segment Guide Pin
32.11	Drain Plug
32.12	Screw
32.15	Stud
32.16	Washer
32.19	Gasket
32.23	Tie Rod
34.00	Thrust Pad Holder
34.01	Adjustment Cover
35.00	PT Sensor Cap
35.01	PT Sensor Dummy
35.02	'O" Ring

In view of continuous developments, the information / descriptions / specifications / illustrations are subject to change without notice.

WATER FILLED REWINDABLE SUBMERSIBLE MOTORS

Nominal Diameter : **12"**

"W" Series

Wellrounder

Exploded view

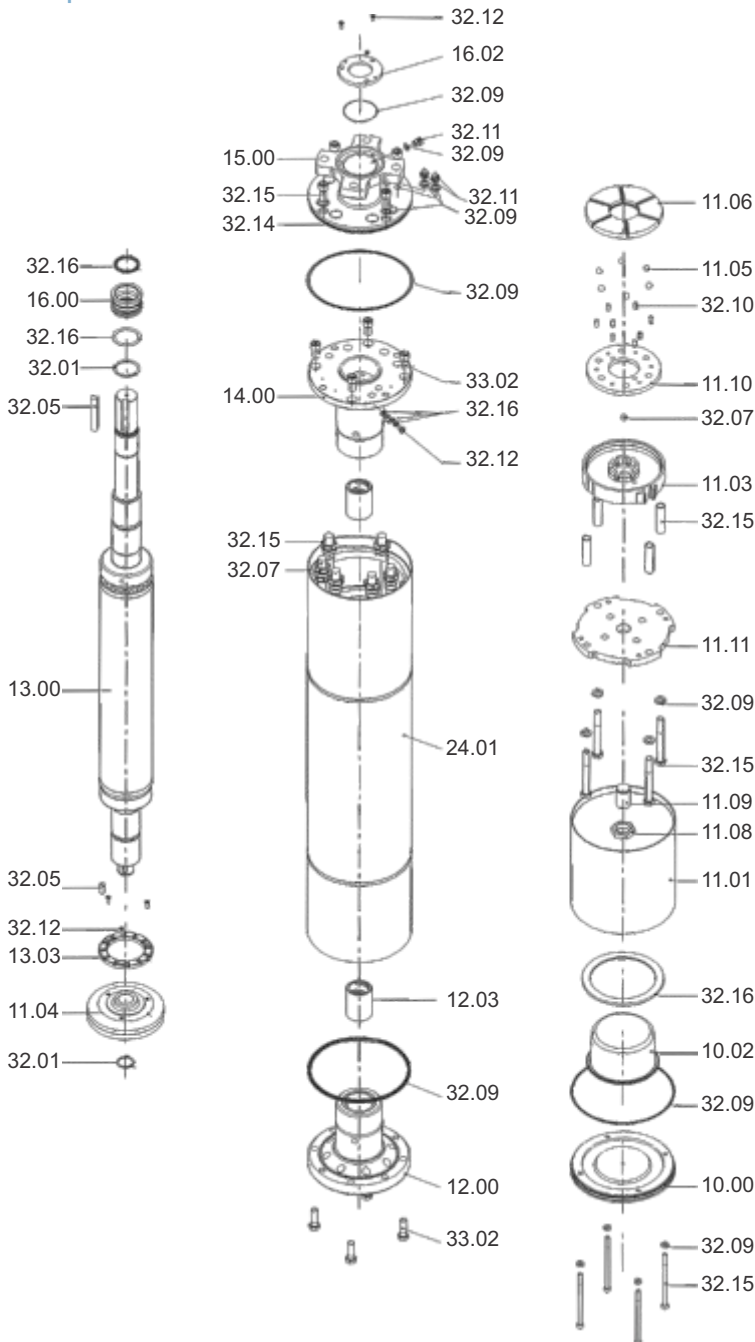

Part No.	Part Name
10.00	Motor base
10.02	Diaphragm
11.01	Thrust base housing
11.03	Thrust bearing bottom
11.04	Thrust Pad
11.05	Ball
11.06	Thrust segment
11.08	Rocker screw nut
11.09	Rocker screw
11.10	Ball guide ring
11.11	Thrust bearing base plate
12.00	Lower housing
12.03	Bush
13.00	Rotor
13.03	Upthrust Washer
14.00	Upper housing
15.00	Seal housing
16.00	Mechanical seal
16.02	Mechanical seal clamp plate
24.01	Wound stator
32.01	Circlip
32.05	Key
32.07	Nut
32.09	O - Ring
32.10	Segment guide pin
32.11	Drain plug
32.12	Screw
32.15	Stud
32.16	Washer
32.23	Tie rod
33.02	Bolt

In view of continuous developments, the information / descriptions / specifications / illustrations are subject to change without notice.

WATER FILLED REWINDABLE SUBMERSIBLE MOTORS

Nominal Diameter : **4"**

"W" Series

Wellrounder

Specifications

Nominal Dia	4" (100mm)
Maximum Outer Diameter	3.81"
Power Range	0.5 HP to 10 HP - Three Phase
Speed	3450 rpm
Version	Three Phase - 220 V, 380 V & 460 V, 60 Hz, A.C Supply
Class of Insulation	Y
Degree of Protection	IP 58
Direction of Rotation	Electrically Reversible
Type of Duty	S1 (Continuous)
Down Thrust Load	0.5 HP to 2 HP - 800 lbs
	3 HP to 10 HP - 1500 lbs
Minimum Cooling Flow Along the Motor	0.25 ft/sec
Maximum Liquid Temperature	91.4°F
Starts per Hour	20 Times
Shaft Type	Splined as per NEMA Standard
Mounting Standard	NEMA Standard
Method of Starting	Three Phase - Direct On Line (DOL)
Cable Lead out	Permanently Connected and Sealed 3/4 Core TPE/EPDM Rubber Flat Cable



Type - A/N

Materials of Construction

Part Name	Type - A	Type - N
Shaft Seal	Nitrile Rubber (NBR)	Nitrile Rubber (NBR)
Housing Shell	SS - 304	SS - 316
Stator Shell	SS - 304 / 441	SS - 316
Thrust Pad	Carbon Graphite	Carbon Graphite
Thrust Bearing	SS - 420	SS - 420
Diaphragm	High Nitrile Rubber	High Nitrile Rubber
Motor Base	SS - 304	SS - 316
Bush	Carbon	Carbon

220, 380 & 460V, THREE PHASE

DIMENSIONS & WEIGHT DATA

Motor Model	HP	Lead Out Cable (Sq.mm)			Height H1		Nett Weight Approx.	
		220 V	380 V	460 V	mm	Inches	kg	lbs
W4A-05-4	0.5	1.5	1.5	-	432	17.0	14.2	31.4
W4A-07-4	0.75	1.5	1.5	-	472	18.6	16.3	35.9
W4A-10-4	1	1.5	1.5	-	502	19.8	17.8	39.2
W4A-15-4	1.5	2.5	1.5	-	560	22.0	20.8	45.8
W4A-20-4	2	2.5	1.5	-	715	28.1	27	59.2
W4A-30-4	3	2.5	1.5	1.5	725	28.5	32	70.4
W4A-40-4	4	2.5	1.5	1.5	890	35.0	36	79.0
W4A-50-4	5	4.0	2.5	2.5	965	37.9	39.7	87.4
W4A-60-4	6	4.0	2.5	2.5	1143	45.0	43.2	95.2
W4A-75-4	7.5	4.0	2.5	2.5	1320	52.0	46.8	103.0
W4A-100-4	10	4.0	2.5	2.5	1422	56.0	47.7	105.0

The last digit of the model number denotes voltage (D = 220V, E = 230V, I = 380V, M = 460V).

In view of continuous developments, the information / descriptions / specifications / illustrations are subject to change without notice.

WATER FILLED REWINDABLE SUBMERSIBLE MOTORS

Nominal Diameter : 4"

"W" Series

Wellrounder

220V, THREE PHASE

TECHNICAL & ELECTRICAL DATA

MODEL	HP	SF	RATED		MAX. S.F.		Efficiency %			Power Factor%			Locked Rotor Amps	Thrust Capacity (lbs)
			Amps	W	Amps	W	S.F.	F.L.	3/4	S.F.	F.L.	3/4		
W4A-05-4D	0.5	1.6	2.3	664	3.1	928	59	56	51	80	75	70	15	800
W4A-07-4D	0.75	1.5	3.6	928	4.3	1264	65	63	57	79	75	64	21	800
W4A-10-4D	1	1.4	4	1136	5.5	1600	68	66	60	80	75	68	25	800
W4A-15-4D	1.5	1.3	5.5	1648	7.3	2032	70	69	65	80	77	71	34	800
W4A-20-4D	2	1.25	8	2280	9.6	2600	71	69	66	78	75	71	44	800
W4A-30-4D	3	1.15	10.4	3120	12	3720	72	72	68	80	78	74	58	1500
W4A-40-4D	4	1.15	15	4160	16.8	4720	71	73	70	78	73	70	75	1500
W4A-50-4D	5	1.15	16.3	4880	19.5	6200	76	75	71	81	79	72	97	1500
W4A-60-4D	6	1.15	19.4	6040	23	6820	76	75	73	82	80	70	115	1500
W4A-75-4D	7.5	1.15	22	7280	27.5	8400	76	75	74	83	80	78	137	1500

380V, THREE PHASE

TECHNICAL & ELECTRICAL DATA

MODEL	HP	SF	RATED		MAX. S.F.		Efficiency %			Power Factor%			Locked Rotor Amps	Thrust Capacity (lbs)
			Amps	W	Amps	W	S.F.	F.L.	3/4	S.F.	F.L.	3/4		
W4A-05-4I	0.5	1.6	1.6	720	1.9	960	50	47	43	78	77	70	10	800
W4A-07-4I	0.75	1.5	1.9	912	2.4	1296	65	63	57	81	75	65	12	800
W4A-10-4I	1	1.4	2.5	1248	3.6	1600	66	64	59	82	75	65	18	800
W4A-15-4I	1.5	1.3	3.4	1728	4.8	2200	67	65	61	81	78	71	24	800
W4A-20-4I	2	1.25	4.2	2256	5.8	2600	69	67	64	81	80	76	29	800
W4A-30-4I	3	1.15	5.6	3024	7.2	3808	74	72	69	83	82	74	36	1500
W4A-40-4I	4	1.15	7.8	4000	9.5	4704	76	75	72	80	78	72	47	1500
W4A-50-4I	5	1.15	9.1	4840	11	5960	76	75	74	82	81	73	55	1500
W4A-60-4I	6	1.15	11.3	6000	13	6780	76	75	74	82	81	72	65	1500
W4A-75-4I	7.5	1.15	13.3	7480	16	8600	75	74	72	83	80	75	80	1500
W4A-100-4I	10	1.15	17.3	9340	20	13165	80	80	79	84	82	78	87	1500

460V, THREE PHASE

TECHNICAL & ELECTRICAL DATA

MODEL	HP	SF	RATED		MAX. S.F.		Efficiency %			Power Factor%			Locked Rotor Amps	Thrust Capacity (lbs)
			Amps	W	Amps	W	S.F.	F.L.	3/4	S.F.	F.L.	3/4		
W4A-30-4M	3	1.15	5.1	3140	5.6	3530	72	70.7	67	79	77	73	26	1500
W4A-40-4M	4	1.15	6.6	3950	7.3	4500	76.8	76	73.5	78	76	70	35	1500
W4A-50-4M	5	1.15	8.1	4800	8.8	5450	78.1	77.4	74.7	77	75	70	42	1500
W4A-60-4M	6	1.15	9.7	5770	10.7	6660	78.3	77.9	75.5	78	75	70	52	1500
W4A-75-4M	7.5	1.15	10.9	6880	12.2	7910	80.4	80.3	79	81	79	73	60	1500
W4A-100-4M	10	1.15	14.8	9240	16.6	10630	81.2	81.3	80	81	79	75	82	1500

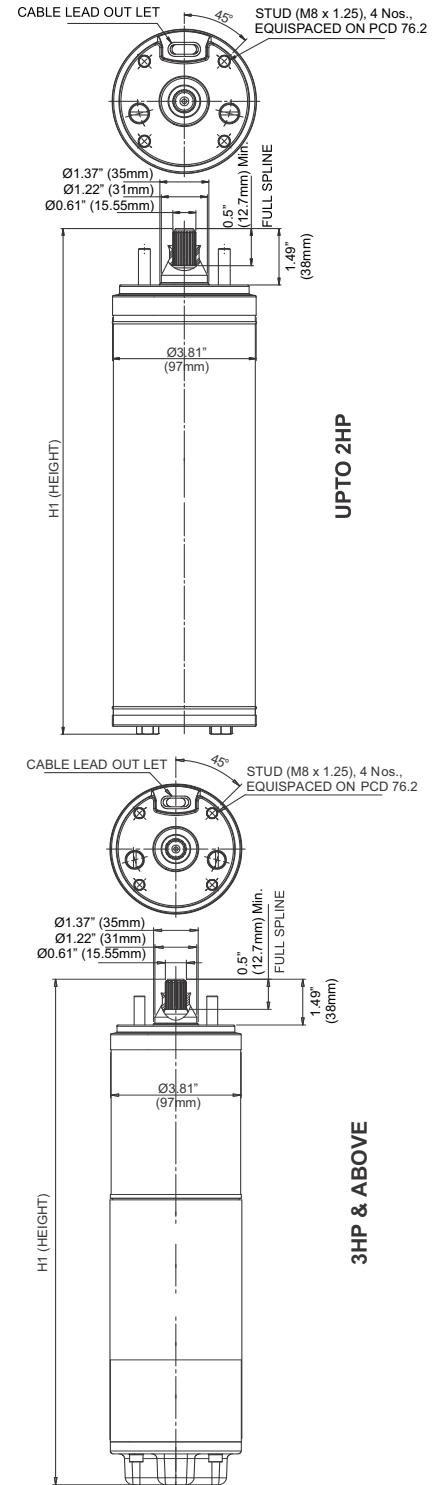

ALL DIMENSIONS ARE IN Inches & mm
 SPLINED SHAFT : 14 TEETH - MODULE 1.5875
 PRESSURE ANGLE 30°, A.N.S.I. B-92-1-1970 COUPLING CLASS 5

In view of continuous developments, the information / descriptions / specifications / illustrations are subject to change without notice.

WATER FILLED REWINDABLE SUBMERSIBLE MOTORS

Nominal Diameter : **6"**

"W" Series

Wellrounder

Specifications

Nominal Dia	6" (150mm)
Maximum Outer Diameter	5.62"
Power Range	5 HP to 60 HP - Three Phase
Speed	3450 rpm
Version	Three Phase - 220 V, 380 V & 460 V, 60 Hz, A.C Supply
Class of Insulation	Y
Degree of Protection	IP 58 / IP 68
Direction of Rotation	CCW - Single Phase
	Electrically Reversible - Three Phase
Type of Duty	S1 (Continuous)
Down Thrust Load	5 HP to 30 HP - 3500 lbs
	35 HP to 60 HP - 6000 lbs
Minimum Cooling Flow Along the Motor	0.5 ft/sec
Maximum Liquid Temperature	91.4°F
Starts per Hour	20 Times
Shaft Type	Splined as per NEMA Standard
Mounting Standard	NEMA Standard
Method of Starting	Three Phase - 5 HP to 60 HP - Direct On Line (DOL)
	Three Phase - 7.5 HP to 60 HP - Star Delta (SD)
Cable Lead out	Permanently Connected and Sealed 3/4 Core PVC / Rubber Insulated Flat Cable
Thermal Protection	High Temperature Motors for 158°F / 194°F can be supplied with PT Sensor and XLPE / PA Winding



* On request motors 440 & 690V can be supplied.

Materials of Construction

Part Name	Type - A	Type - N
Shaft Seal / Mechanical Seal	Nitrile Rubber (NBR) / Ceramic - Carbon	Nitrile Rubber (NBR) / Ceramic - Carbon
Upper & Lower Housings	Cast Iron	Cast Iron
Stator Shell	SS - 304 / SS - 441	SS - 316
Thrust Pad	Carbon Graphite	Carbon Graphite
Thrust Bearing	SS - 420	SS - 420
Diaphragm	High Nitrile Rubber	High Nitrile Rubber
Motor Base	SS - 304	SS - 316
Upper Housing Shell	SS - 304	SS - 316
Shaft	EN-8	EN-8
Shaft Extension	17.4 Ph	17.4 Ph
Sleeves	SS - 431	SS - 431

WATER FILLED REWINDABLE SUBMERSIBLE MOTORS

Nominal Diameter : **6"**

"W" Series

Wellrounder

220V, THREE PHASE

DIMENSIONS & WEIGHT DATA

Motor Model	HP	Lead Out Cable Size (Sq.mm)	Height H1		Nett Weight Approx.	
			mm	Inches	kg	lbs
W6A-50-4D	5	4	734	28.8	40.8	89.9
W6A-75-4D	7.5	6	804	31.6	50.9	112
W6A-100-4D	10	6	854	33.6	53.6	118
W6A-125-4D	12.5	10	884	34.7	55.9	123
W6A-150-4D	15	10	924	36.3	63.6	140
W6A-200-4D	20	10	1004	39.5	72.7	160
W6A-250-4D	25	16	1084	42.6	81.3	179
W6A-300-4D	30	16	1154	45.4	90.9	200
W6A-400-4D	40	16	1229	48.3	93.6	206

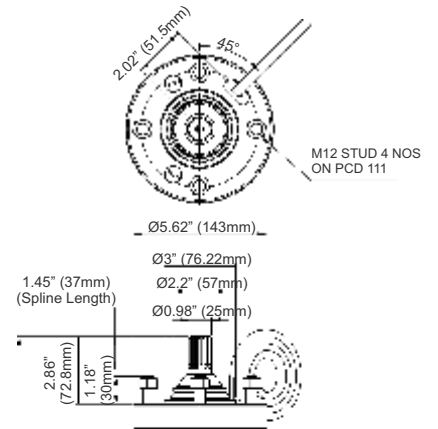

220V, THREE PHASE

TECHNICAL & ELECTRICAL DATA

MODEL	HP	SF	RATED		MAX. S.F.		EFF. %			Power Factor %			Locked Rotor Amps	Max. Down Thrust Load (lbs)
			A	W	A	W	S.F.	F.L.	3/4	S.F.	F.L.	3/4		
W6A-50-4D	5	1.15	16	4840	18.5	5480	77.5	76.6	76.5	80.9	78.6	76.1	88	3500
W6A-75-4D	7.5	1.15	22	6850	25	7860	80	80.5	79.6	82.5	81.7	77	130	3500
W6A-100-4D	10	1.15	29.5	9280	33.9	10640	82	81.5	80	82.5	82.5	79	175	3500
W6A-125-4D	12.5	1.15	36	11360	41	13020	80.5	81.8	80.6	83.3	82.8	80	216	3500
W6A-150-4D	15	1.15	44	13620	49	15400	80.5	80.8	80.2	82.5	81.2	80.5	265	3500
W6A-200-4D	20	1.15	56	18180	64.4	20940	82	82.5	80	85.3	85.2	82	348	3500
W6A-250-4D	25	1.15	68	22680	78.2	26000	82.5	82.2	81.5	87.2	87.5	83	468	3500
W6A-300-4D	30	1.15	80.5	26880	92	30600	82.5	82	82	83.5	84	82	547	3500
W6A-400-4D	40	1.15	116	36240	133	41700	82.5	82.8	80	82.3	82	80	750	6000

H1 (HEIGHT)

The above mentioned electrical data are applicable for Star-Delta motors also
 Note: Star-Delta motors are available from 7.5 H.P. onwards.

ALL DIMENSIONS ARE IN Inches & mm
 Splined Shaft : 15 teeth -
 Module 1.5875
 Pressure Angle 30°
 A.N.S.I.B-92-1-1970
 Tolerance Class 5

WATER FILLED REWINDABLE SUBMERSIBLE MOTORS

Nominal Diameter : **6"**

"W" Series

Wellrounder

380V, THREE PHASE

DIMENSIONS & WEIGHT DATA

Model	HP	Lead Out Cable Size (Sq.mm)	Height H1		Nett Weight Approx.	
			mm	Inches	kg	lbs
W6A-60-4I	6.0	2.5	754	29.6	44.3	97.66
W6A-75-4I	7.5	4	804	31.6	49.7	109.52
W6A-100-4I	10	4	854	33.6	54.7	120.69
W6A-125-4I	12.5	6	884	34.7	58	127.91
W6A-150-4I	15	6	924	36.3	62.8	138.38
W6A-175-4I	17.5	6	964	37.9	67	147.58
W6A-200-4I	20	10	1004	39.5	71.2	157.04
W6A-250-4I	25	10	1084	42.6	79.6	175.47
W6A-300-4I	30	10	1154	45.4	85.5	188.43
W6A-400-4I	40	10	1229	48.3	93.7	206.76
W6A-500-4I	50	16	1304	51.2	97.9	215.75
W6A-600-4I	60	16	1379	54.2	99.7	220

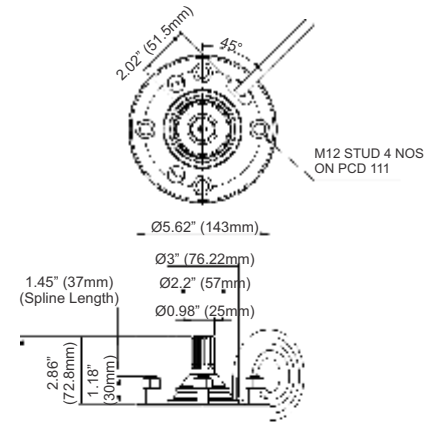

380V, THREE PHASE

TECHNICAL & ELECTRICAL DATA

MODEL	HP	SF	RATED		MAX. S.F.		Efficiency %			Power Factor%			Locked Rotor Amps	Thrust Capacity (lbs)
			Amps	W	Amps	W	S.F	F.L.	3/4	S.F	F.L.	3/4		
W6A-60-4I	6	1.15	11	6000	13	6900	76	75	74	83	82	82	55	3500
W6A-75-4I	7.5	1.15	13.5	7200	15.5	8520	77	76	76	86	85	85	66	3500
W6A-100-4I	10	1.15	17.1	9640	19.5	10900	79	78	78	88	87	85	84	3500
W6A-125-4I	12.5	1.15	20.2	11800	23	13580	80	79	79	89	87	87	104	3500
W6A-150-4I	15	1.15	24.6	13680	28	15500	82	81	80	84	83	82	132	3500
W6A-175-4I	17.5	1.15	24.6	13680	34	15500	82	81	80	84	83	82	132	3500
W6A-200-4I	20	1.15	33	18850	37.5	21580	80	80	80	87	86	85	180	3500
W6A-250-4I	25	1.15	37.5	21760	43	25000	85	86	85	90	91	89	230	3500
W6A-300-4I	30	1.15	47.5	25920	54.6	29600	85	86	85	84	84	83	300	3500
W6A-400-4I	40	1.15	65	36000	75	41300	83.5	84	83.6	83.5	84	81	380	6000
W6A-500-4I	50	1.15	83	44640	95	51320	83	83	82.5	82	82	81	450	6000
W6A-600-4I	60	1.15	97	54200	112	63200	82	83	82	85	84	84	530	6000

H1 (HEIGHT)



ALL DIMENSIONS ARE IN Inches & mm
 Splined Shaft : 15 teeth -
 Module 1.5875
 Pressure Angle 30°
 A.N.S.I.B-92-1-1970
 Tolerance Class 5

The above mentioned electrical data are applicable for Star-Delta motors also
 Note: Star-Delta motors are available from 7.5 H.P. onwards.

WATER FILLED REWINDABLE SUBMERSIBLE MOTORS

Nominal Diameter : **6"**

"W" Series

Wellrounder

460V, THREE PHASE

DIMENSIONS & WEIGHT DATA

Motor Model	HP	Lead Out Cable Size (Sq.mm)	Height H1		Nett Weight Approx.	
			mm	Inches	kg	lbs
W6A-50-4M	5	2.5	734	28.8	42.1	93
W6A-60-4M	6	4	754	29.6	45	99
W6A-75-4M	7.5	4	804	31.6	50.3	111
W6A-100-4M	10	4	854	33.6	55.8	123
W6A-125-4M	12.5	6	884	34.7	58.5	129
W6A-150-4M	15	6	924	36.3	64	141
W6A-200-4M	20	10	1004	39.5	72.1	159
W6A-250-4M	25	10	1084	42.6	80.2	177
W6A-300-4M	30	10	1154	45.4	86.1	190
W6A-350-4M	35	16	1174	46.1	89	196
W6A-400-4M	40	16	1229	48.3	94	208
W6A-500-4M	50	16	1304	51.2	98.4	217
W6A-600-4M	60	16	1379	54.2	103.4	228



460V, THREE PHASE

TECHNICAL & ELECTRICAL DATA

MODEL	HP	SF	RATED		MAX. S.F.		EFF. %			Power Factor %			Locked Rotor Amps	Max. Down Thrust Load (lbs)
			Amps	W	Amps	W	S.F	F.L.	3/4	S.F	F.L	3/4		
W6A-50-4M	5	1.15	7.9	4680	8.5	5120	80.5	79	77.5	76	78.5	75.9	38	3500
W6A-60-4M	6	1.15	9	5900	10.5	6720	81	82	80	83	82	78	48	3500
W6A-75-4M	7.5	1.15	11	7000	12.5	8050	78	79	78.5	81	80	79.5	60	3500
W6A-100-4M	10	1.15	14	9260	16	10600	80	81	80	82	78	77	78	3500
W6A-125-4M	12.5	1.15	17.6	11680	19.8	13400	79.8	80	79.5	84	82	81.5	90	3500
W6A-150-4M	15	1.15	21	13200	23.5	15300	82.5	83	82	81.7	80	79	120	3500
W6A-200-4M	20	1.15	27	18200	31	20800	82	82.5	82	88	86	85.5	165	3500
W6A-250-4M	25	1.15	33	22320	37	25600	82.5	83	82.2	86.8	82.5	82	220	3500
W6A-300-4M	30	1.15	38.8	26750	44.5	30750	82.5	83.5	82	86.5	85	82	260	3500
W6A-350-4M	35	1.15	48	31200	55	35800	82	84	82	82	82	81.5	290	6000
W6A-400-4M	40	1.15	53.5	35760	61.5	41160	83.5	84	83.5	83.3	83.8	83	330	6000
W6A-500-4M	50	1.15	67	44160	77	51500	83	84.5	84	84	83	80	390	6000
W6A-600-4M	60	1.15	85	56400	96	65000	80.5	81	80.5	85	83	79	425	6000

The above mentioned electrical data are applicable for Star-Delta motors also

Note: Star-Delta motors are available from 7.5 H.P. onwards.

In view of continuous developments, the information / descriptions / specifications / illustrations are subject to change without notice.

WATER FILLED REWINDABLE SUBMERSIBLE MOTORS

Nominal Diameter : **8"**

"W" Series

Wellrounder

Specifications

Nominal Dia	8" (200mm)
Maximum Outer Diameter	7.71"
Power Range	50 HP to 125 HP - Three Phase
Speed	3450 rpm
Version	Three Phase - 380 V & 460 V, 60 Hz, A.C Supply
Class of Insulation	Y
Degree of Protection	IP 58 / IP 68
Direction of Rotation	Electrically Reversible - Three Phase
Type of Duty	S1 (Continuous)
Down Thrust Load	50 HP to 60 HP - 10000 lbs
	75 HP to 125 HP - 12500 lbs
Minimum Cooling Flow Along the Motor	0.5 ft/sec
Maximum Liquid Temperature	91.4°F
Starts per Hour	10 Times
Shaft Type	Splined as per NEMA Standard
Mounting Standard	NEMA Standard
Method of Starting	Three Phase - 50 HP to 125 HP - Direct On Line (DOL)
	Three Phase - 50 HP to 125 HP - Star Delta (SD)
Cable Lead out	Permanently Connected and Sealed 3/4 Core PVC / Rubber Insulated Flat Cable
Thermal Protection	High Temperature Motors for 158°F / 194°F can be supplied with PT Sensor and XLPE / PA Winding

* On request motors 440V & 690V can be supplied.



Materials of Construction

Part Name	Type - B	Type - S
Shaft Seal Housing	Cast Iron	SS - 304 Casted
Shaft Seal / Mechanical Seal	Nitrile Rubber (NBR) / Ceramic - Carbon, SiC - SiC	Nitrile Rubber (NBR) / Ceramic - Carbon, SiC - SiC
Upper & Lower Housings	Cast Iron	SS - 304 Casted
Stator Shell	SS - 304	SS - 304
Thrust Pad	Carbon Graphite	Carbon Graphite
Thrust Bearing	SS - 420	SS - 420
Diaphragm	High Nitrile Rubber	High Nitrile Rubber
Motor Base	Cast Iron	SS - 304 Casted
Shaft	EN-8	EN-8
Shaft Extension	17.4 Ph	17.4 Ph
Sleeves	SS - 431	SS - 431

WATER FILLED REWINDABLE SUBMERSIBLE MOTORS

Nominal Diameter : **8"**

"W" Series

Wellrunder

380V & 460V, THREE PHASE

DIMENSIONS & WEIGHT DATA

Motor Model	HP	Lead Out Cable Size (Sq.mm)	Height H1		Nett Weight Approx.	
			mm	Inches	kg	lbs
W8B-500-4M	50	16	1181	46.4	153.3	338
W8B-600-4M	60	16	1231	48.4	164.2	362
W8B-750-4M	75	35	1281	50.3	179.1	395
W8B-850-4M	85	35	1351	53.1	192.7	425
W8B-A00-4M	100	35	1466	57.6	214.5	473
W8B-A25-4M	125	35	1556	61.2	234	516

380V, THREE PHASE

TECHNICAL & ELECTRICAL DATA

MODEL	HP	SF	RATED		MAX. S.F.		Efficiency %			Power Factor%			Locked Rotor Amps	Thrust Capacity (lbs)
			Amps	W	Amps	W	S.F.	F.L.	3/4	S.F.	F.L.	3/4		
W8B-500-4M	50	1.15	84	43100	93	49300	86	86	85	80	79	74	500	10000
W8B-600-4M	60	1.15	98	51940	109	59900	87	87	86	83	82	76	590	10000
W8B-750-4M	75	1.15	116	63500	131	73300	86	86	85	85	83	78	710	12500
W8B-850-4M	85	1.15	135	73500	152	84900	87	87	84	85	83	79	820	12500
W8B-A00-4M	100	1.15	155	84850	175	97850	88	88	88	85	83	78	945	12500
W8B-A25-4M	125	1.15	198	107200	223	123000	86	86	86	84	82	76	1200	12500

460V, THREE PHASE

TECHNICAL & ELECTRICAL DATA

MODEL	HP	SF	RATED		MAX. S.F.		Efficiency %			Power Factor%			Locked Rotor Amps	Thrust Capacity (lbs)
			Amps	W	Amps	W	S.F.	F.L.	3/4	S.F.	F.L.	3/4		
W8B-500-4M	50	1.15	66	43100	75	49800	86	86	85	83	82	80	450	10000
W8B-600-4M	60	1.15	78	52400	88.5	60200	88	87	86	85	85	83	530	10000
W8B-750-4M	75	1.15	96	64400	110	74200	86	85	84	85	84	82	720	12500
W8B-850-4M	85	1.15	106	72500	122	84000	87	87	85	86	85	83	790	12500
W8B-A00-4M	100	1.15	126	85400	145	99200	87	88	86	85	85	83	940	12500
W8B-A25-4M	125	1.15	155	105600	177	122800	88	88	86	87	86	84	1150	12500

The above mentioned electrical data are applicable for Star-Delta motors also.

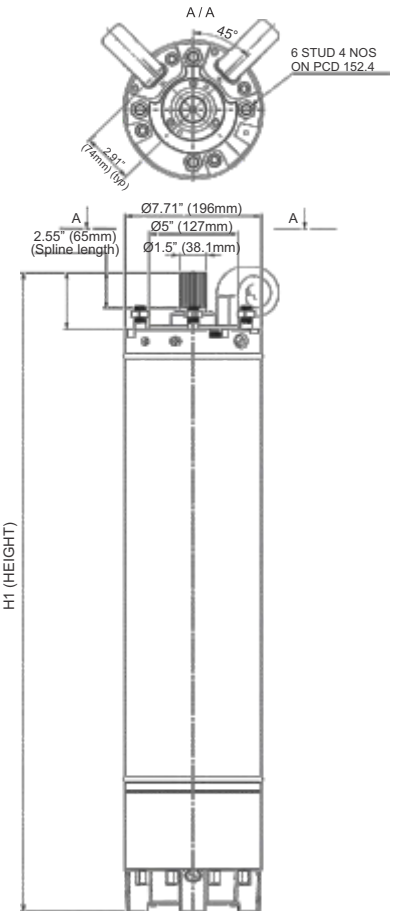

All Dimensions are in Inches & mm
 Splined Shaft : 23 teeth -
 Module 1.5875 Pressure Angle 30°
 A.N.S.I.B92-1 Tolerance Class 5

WATER FILLED REWINDABLE SUBMERSIBLE MOTORS

Nominal Diameter : **10"**

"W" Series

Wellrounder

Specifications

Nominal Dia	10" (250mm)
Maximum Outer Diameter	9.1"
Power Range	100 HP to 250 HP - Three Phase
Speed	3490 rpm
Version	Three Phase - 380 V & 460 V, 60 Hz, A.C Supply
Class of Insulation	Y
Degree of Protection	IP 68
Direction of Rotation	Electrically Reversible - Three Phase
Type of Duty	S1 (Continuous)
Down Thrust Load	100 HP to 250 HP - 16860 lbs
Minimum Cooling Flow Along the Motor	0.5 ft/sec
Maximum Liquid Temperature	86°F
Starts per Hour	10 Times
Shaft Type	Splined as per NEMA Standard
Mounting Standard	NEMA Standard
Method of Starting	Three Phase - Direct On Line (DOL) Three Phase - Star Delta (SD)
Cable Lead out	Permanently Connected and Sealed 3/4 Core Rubber Insulated Flat Cable
Thermal Protection	High Temperature Motors for 158°F / 194°F can be supplied with PT Sensor and PE2 / PA Winding



Type - A/N

Type - B

* On request motors 440V & 690V can be supplied.

Materials of Construction

Part Name	Type - A	Type - N	Type - B
Shaft Seal Housing	SS - 304	SS - 316	Cast Iron
Shaft Seal / Mechanical Seal	Nitrile Rubber (NBR) / Ceramic - Carbon, SiC - SiC	Nitrile Rubber (NBR) / Ceramic - Carbon, SiC - SiC	Nitrile Rubber (NBR) / Ceramic - Carbon, SiC - SiC
Upper & Lower Housings	SS - 304	SS - 316	Cast Iron
Stator Shell	SS - 304	SS - 316	SS - 304
Thrust Pad	Carbon Graphite	Carbon Graphite	Carbon Graphite
Thrust Bearing	SS - 420	SS - 420	SS - 420
Diaphragm	Nitrile Rubber (NBR)	Nitrile Rubber (NBR)	Nitrile Rubber (NBR)
Motor Base	SS - 304	SS - 316	Cast Iron

WATER FILLED REWINDABLE SUBMERSIBLE MOTORS

Nominal Diameter : **10"**

"W" Series

Wellrounder

380V & 460V - THREE PHASE

DIMENSIONS & WEIGHT DATA

Motor Models	Motor Power		Lead Out Cable Size (Sq.mm)		Height H1		Nett Weight Approx.	
	kW	HP	DOL	SD	mm	Inches	kg	lbs
W10A-A00-4	75	100	25	16	1226	18.9	239.4	528
W10A-A10-4	81	110	25	16	1266	19.6	259.4	572
W10A-A25-4	93	125	25	16	1316	20.3	273.5	603
W10A-A50-4	110	150	25	25	1446	22.3	313.4	691
W10A-A75-4	130	175	25	25	1546	23.9	341.1	752
W10A-B00-4	150	200	35	35	1736	26.8	364.2	803
W10A-B25-4	165	225	35	35	1856	28.7	408.2	900
W10A-B50-4	185	250	35	35	1956	30.2	439.0	968

380V DOL & SD MOTORS - THREE PHASE

TECHNICAL & ELECTRICAL DATA

Model	Motor Power		Method of Starting	Full Load Current (A)	Starting Current (A)	Efficiency (%)	Power Factor	Max. Down Thrust Load (lbs)	Cable Size (Sq.mm)	
	kW	HP							DOL No. of Leadouts	SD No. of Leadouts
W10A-A00-4I	75	100	T / D	150	225	86	0.87	16860	1	2
W10A-A10-4I	81	110	T / D	166	249	86	0.87	16860	1	2
W10A-A25-4I	93	125	T / D	181	272	87	0.89	16860	1	2
W10A-A50-4I	110	150	T / D	220	330	87	0.89	16860	2	2
W10A-A75-4I	130	175	T / D	255	383	87	0.89	16860	2	2
W10A-B00-4I	150	200	T / D	290	435	88	0.89	16860	2	2
W10A-B25-4I	165	225	T / D	325	488	88	0.89	16860	2	2
W10A-B50-4I	185	250	T / D	355	533	89	0.90	16860	2	2

460V DOL & SD MOTORS - THREE PHASE

TECHNICAL & ELECTRICAL DATA

Motor Model	Motor Power		Method of Starting	Full Load Current (A)	Starting Current (A)	Efficiency (%)	Power Factor	Max. Down Thrust Load (lbs)	Cable Size (Sq.mm)	
	kW	HP							DOL No. of Leadouts	SD No. of Leadouts
W10A-A00-4M	75	100	T / D	130	194	86	0.87	16860	1	2
W10A-A10-4M	81	110	T / D	143	215	86	0.87	16860	1	2
W10A-A25-4M	93	125	T / D	156	234	87	0.89	16860	1	2
W10A-A50-4M	110	150	T / D	190	285	87	0.89	16860	2	2
W10A-A75-4M	130	175	T / D	220	330	87	0.89	16860	2	2
W10A-B00-4M	150	200	T / D	250	376	88	0.89	16860	2	2
W10A-B25-4M	165	225	T / D	281	421	88	0.89	16860	2	2

METHOD OF STARTING : T - 3P / DOL / 60Hz D - 3P / SD / 60Hz

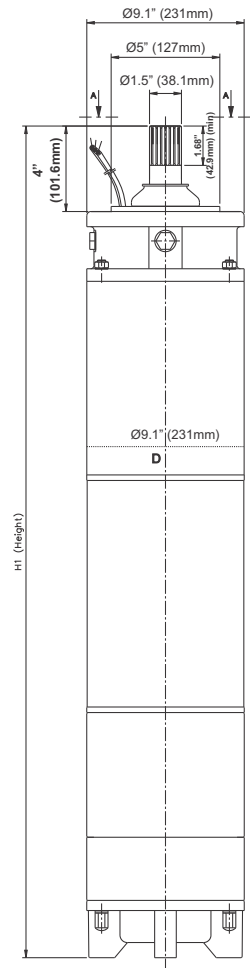

ALL DIMENSIONS ARE IN Inches & mm.

WATER FILLED REWINDABLE SUBMERSIBLE MOTORS

Nominal Diameter : **12"**

"W" Series

Wellrounder

Specifications

Nominal Dia	12" (300mm)
Maximum Outer Diameter	10.7"
Power Range	250 HP to 600 HP - Three Phase
Speed	3460 rpm
Version	Three Phase - 380 V & 460 V, 60 Hz, A.C Supply
Class of Insulation	Y
Degree of Protection	IP 68
Direction of Rotation	Electrically Reversible - Three Phase
Type of Duty	S1 (Continuous)
Down Thrust Load	250 HP to 600 HP - 13500 lbs
Minimum Cooling Flow Along the Motor	1.64 ft/sec (86°F), 2 ft/sec (122°F)
Maximum Liquid Temperature	86°F
Starts per Hour	10 Times
Shaft Type	Key Way
Mounting Standard	International Standard
Method of Starting	Three Phase - Direct On Line (DOL) Three Phase - Star Delta (SD)
Cable Lead out	Permanently Connected and Sealed 3/4 Core Rubber Insulated Flat Cable
Thermal Protection	High Temperature Motors for 158°F / 194°F can be supplied with PT Sensor and XLPE / PA Winding



Type - A/N Type - B

* On request motors 440V & 690V can be supplied.

Materials of Construction

Part Name	Type - A	Type - N	Type - B
Seal Housing	SS - 304	SS - 316	Cast Iron
Mechanical Seal	Carbon / Ceramic SiC - SiC*	SiC - SiC	Carbon / Ceramic SiC - SiC*
Upper & Lower Housings	SS - 304	SS - 316	Cast Iron
Stator Shell	SS - 304	SS - 316	SS - 304
Thrust Pad	SS / Carbon	SS / Carbon	SS / Carbon
Thrust Bearing	SS / Carbon	SS / Carbon	SS / Carbon
Diaphragm	Nitrile Rubber (NBR)	Nitrile Rubber (NBR)	Nitrile Rubber (NBR)
Motor Base	SS - 304	SS - 316	Cast Iron
Shaft	SS - 304	Duplex Steel	SS - 304

* Optional.

WATER FILLED REWINDABLE SUBMERSIBLE MOTORS

Nominal Diameter : **12"**

"W" Series

Wellrounder

380V & 460V - THREE PHASE

DIMENSIONS & WEIGHT DATA

Model	Motor Power		Lead Out Cable Size (Sq.mm)		Height H1		Nett Weight Approx.	
	kW	HP	380V	460V	mm	Inches	kg	lbs
W12A-B50-4	185	250	95	70	1762	69.4	413	970
W12A-C00-4	225	300	70	95	1833	72.2	461.3	1017
W12A-C50-4	260	350	70	120	1920	75.6	497.1	1096
W12A-D00-4	300	400	95	70	1996	78.6	526.1	1160
W12A-D50-4	330	450	95	95	2090	82.3	566	1248
W12A-E00-4	375	500	120	95	2141	84.5	585.1	1290
W12A-E50-4	400	550	150	120	2210	87.0	611	1347
W12A-F00-4	450	600	150	120	2270	89.4	636.8	1404

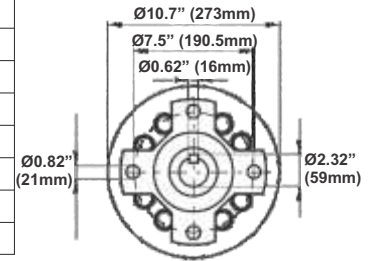

380 V - THREE PHASE

TECHNICAL & ELECTRICAL DATA

Model	Motor Power		Method of Starting	Full Load Max (A)	Starting Current (A)	Full load		Max. Down Thrust Load (lbs)	No. of Leadouts
	kW	HP				Eff.%	Power Factor		
W12A-B50-4I	185	250	T	380	1938	87	85	13500	3
W12A-C00-4I	225	300	T / D	465	2279	87	85	13500	6
W12A-C50-4I	260	350	T / D	535	2568	87	85	13500	6
W12A-D00-4I	300	400	T / D	625	3125	86	85	13500	6
W12A-D50-4I	330	450	T / D	690	3312	86	85	13500	6
W12A-E00-4I	375	500	T / D	780	3900	86	85	13500	6
W12A-E50-4I	400	550	T / D	855	4446	85	84	13500	6
W12A-F00-4I	450	600	T / D	960	5088	85	84	13500	6

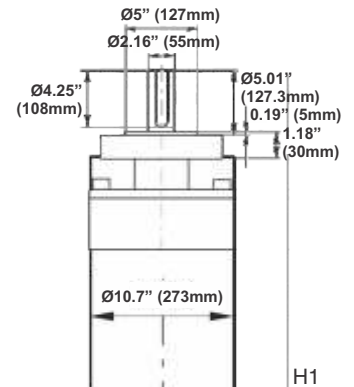

460 V - THREE PHASE

TECHNICAL & ELECTRICAL DATA

Model	Motor Power		Method of Starting	Full Load Max (A)	Starting Current (A)	Full load		Max. Down Thrust Load (lbs)	No. of Leadouts
	kW	HP				Eff.%	Power Factor		
W12A-B50-4M	185	250	T	314	1601	87	85	13500	3
W12A-C00-4M	225	300	T	384	1882	87	85	13500	3
W12A-C50-4M	260	350	T	442	2122	87	85	13500	3
W12A-D00-4M	300	400	T / D	516	2580	86	85	13500	6
W12A-D50-4M	330	450	T / D	570	2736	86	85	13500	6
W12A-E00-4M	375	500	T / D	644	3220	86	85	13500	6
W12A-E50-4M	400	550	T / D	706	3671	85	84	13500	6
W12A-F00-4M	450	600	T / D	793	4203	85	84	13500	6

ALL DIMENSIONS ARE IN Inches & mm.

METHOD OF STARTING : T - 3P / DOL / 60Hz D - 3P / SD / 60Hz

CABLE SELECTION TABLE

		1Ph, 2/3 WIRE MOTORS, MAXIMUM LENGTH OF COPPER CABLE IN FEET													
		Motor Rating	CABLE SIZE IN AMERICAN WIRE GAGE												
VOLT	HP	Calculate Cable Length (FEET)	14	12	10	8	6	4	3	2	1	1/0	2/0	3/0	4/0
110V	0.5		95	151	239	381	604	963	1213	1529	1928	2429	3065	3865	4873
	0.75		75	119	190	302	479	764	962	1213	1529	1926	2431	3065	3865
	1		68	108	172	274	434	692	872	1099	1386	1746	2203	2778	3503
	1.5		54	87	138	219	347	554	697	879	1108	1397	1762	2222	2802
220V	0.5		345	550	1390	2203	3515	4427	5584	7038	8868				
	0.75		262	417	1055	1672	2668	3360	4238	5342	6731	8493			
	1		203	324	819	1297	2069	2607	3288	4144	5221	6588			
	1.5		177	282	712	1129	1800	2268	2860	3605	4542	5731			
	2		165	262	664	1052	1677	2113	2665	3359	4232	5340			
	3	122	195	492	780	1244	1567	1976	2491	3139	3960				
	5			313	496	791	996	1256	1583	1995	2518				

		THREE PHASE 3 WIRE (D.O.L.) MOTOR MAXIMUM LENGTH OF COPPER CABLE - SINGLE CABLE PER PHASE														
		Motor Rating	CABLE SIZE IN AMERICAN WIRE GAUGE													
VOLT	HP	Calculate Cable Length (FEET)	14	12	10	8	6	4	3	2	1	1/0	2/0	3/0	4/0	
220V	0.5		842	1341	2130	3391	5373									
	0.8		607	967	1535	2445	3874	6179								
	1.0		475	756	1200	1911	3029	4831	6085							
	1.5		358	569	904	1440	2282	3640	4585	5782						
	2.0		272	433	688	1095	1735	2768	3486	4397	5542					
	3.0		218	346	550	876	1388	2214	2789	3518	4434	5587	7049			
	4.0		155	247	393	626	992	1582	1992	2513	3167	3991	5035			
	5.0		112	178	282	449	712	1135	1430	1804	2274	2865	3615	4559	5748	
	6.0		95	151	239	381	604	963	1213	1529	1928	2429	3065	3865	4873	
	7.5			126	200	319	505	805	1014	1279	1612	2032	2563	3233	4076	
	10.0			99	157	250	397	633	797	1005	1267	1596	2014	2540	3202	
	12.5				134	214	339	540	680	858	1081	1363	1719	2168	2734	
	15.0				112	179	283	452	569	718	905	1140	1439	1814	2287	
	17.5				97	154	244	388	489	617	778	980	1237	1560	1966	
	20.0					136	216	344	433	546	688	868	1095	1380	1740	
	25.0					112	178	283	357	450	567	714	901	1137	1433	
	30.0						151	241	303	382	482	607	766	966	1218	
	35.0							108	172	217	274	345	435	549	692	873
	40.0							147	185	233	293	370	466	588	742	
50.0								130	164	206	260	328	414	522	658	

		THREE PHASE 3 WIRE (S.D) MOTOR MAXIMUM LENGTH OF COPPER CABLE														
		Motor Rating	CABLE SIZE IN AMERICAN WIRE GAUGE													
VOLT	HP	Calculate Cable Length (FEET)	14	12	10	8	6	4	3	2	1	1/0	2/0	3/0	4/0	
220V	0.5		1769	2816	4472	7121	11284									
	0.8		1275	2030	3224	5134	8135	12976								
	1.0		997	1587	2521	4014	6360	10145	12779							
	1.5		751	1196	1899	3024	4792	7643	9628	12143						
	2.0		571	909	1444	2299	3644	5812	7321	9234	11639					
	3.0		457	727	1155	1840	2915	4650	5857	7387	9311	11732	14803			
	4.0		326	520	825	1314	2082	3321	4184	5276	6651	8380	10574			
	5.0		234	373	592	943	1495	2384	3004	3788	4775	6017	7591	9573	12071	
	6.0		199	316	502	800	1267	2022	2547	3212	4048	5101	6436	8116	10234	
	7.5			264	420	669	1060	1691	2130	2686	3386	4266	5383	6788	8559	
	10.0			208	330	526	833	1329	1673	2111	2660	3352	4229	5334	6725	
	12.5				282	449	711	1134	1429	1802	2271	2862	3610	4553	5741	
	15.0				236	375	595	949	1195	1508	1900	2394	3021	3810	4804	
	17.5				203	323	511	816	1028	1296	1633	2058	2597	3275	4129	
	20.0					286	453	722	909	1147	1446	1822	2299	2899	3655	
	25.0					235	373	595	749	945	1191	1500	1893	2387	3010	
	30.0						317	505	637	803	1012	1275	1609	2029	2558	
	35.0						227	362	456	575	725	914	1153	1454	1833	
	40.0						308	388	489	616	776	979	1235	1557		
50.0						273	344	433	546	688	868	1095	1381			

CABLE SELECTION TABLE

		THREE PHASE 3 WIRE (D.O.L.) MOTOR MAXIMUM LENGTH OF COPPER CABLE - SINGLE CABLE PER PHASE																		
VOLT	Motor Rating	CABLE SIZE IN AMERICAN WIRE GAGE													MCM Copper wire size					
	HP	14	12	10	8	6	4	3	2	1	1/0	2/0	3/0	4/0	250	300	350	400	500	
380V	Calculate Cable Length (FEET)	0.5	2374	3779	6002	9556	15143													
		0.8	1879	2991	4751	7565	11988													
		1.0	1253	1994	3168	5044	7992													
		1.5	940	1496	2376	3783	5994													
		2.0	778	1238	1966	3131	4961													
		3.0	626	997	1584	2522	3996													
		4.0	475	756	1200	1911	3029													
		5.0		544	864	1376	2180													
		6.0		460	731	1164	1844	2942												
		7.5		374	594	946	1499	2390												
		10.0		288	457	727	1153	1839												
		12.5		239	380	605	959	1530												
		15.0			322	513	813	1296	1633											
		17.5			291	463	733	1170	1587											
		20.0				362	573	954	1301	1894										
		25.0				321	509	812	983	1240	1563									
		30.0					426	680	922	1163	1466	1848								
		35.0						603	818	1031	1300	1638								
		40.0						503	634	799	887	1117	1410	1778						
		50.0						403	507	640	806	894	1128	1293	1630					
		60.0							477	602	618	779	983	1183	1421					
		75.0								558	552	696	798	1007	1270					
		85.0								516	511	643	738	931	1173					
		100.0									438	551	696	877	974	886				
		125.0										442	558	704	887	807	1145			
		150.0											534	673	849	748	1061			
175.0												660	849	661	937	994				
200.0														500	709	745				
225.0															647	754	798	1078		
250.0															492	574	607	820		
300.0																552	584	788		
350.0																	507	685		
400.0																		434	586	

		THREE PHASE 3 WIRE (S.D) MOTOR MAXIMUM LENGTH OF COPPER CABLE																		
VOLT	Motor Rating	CABLE SIZE IN AMERICAN WIRE GAGE													MCM Copper wire size					
	HP	14	12	10	8	6	4	3	2	1	1/0	2/0	3/0	4/0	250	300	350	400	500	
380V	Calculate Cable Length (FEET)	0.5	4985	7935	12604	20068	31800													
		0.8	3946	6282	9978	15887	25175													
		1.0	2631	4188	6652	10592	16784													
		1.5	1973	3141	4989	7944	12588													
		2.0	1633	2599	4129	6574	10417													
		3.0	1315	2094	3326	5296	8392													
		4.0	997	1587	2521	4014	6360													
		5.0		1142	1814	2889	4577													
		6.0		966	1535	2444	3873	6178												
		7.5			785	1247	1986	3147	5020											
		10.0			604	959	1528	2421	3861											
		12.5			503	798	1271	2014	3213											
		15.0				676	1077	1707	2723	3429										
		17.5				610	972	1540	2457	3333										
		20.0					759	1203	2003	2733	3977									
		25.0					674	1069	1705	2065	2604	3282								
		30.0						895	1428	1937	2443	3079	3880							
		35.0							1266	1717	2165	2729	3439							
		40.0							1057	1331	1679	1862	2346	2961	3734					
		50.0							845	1065	1343	1693	1877	2368	2715	3424				
		60.0								1002	1264	1298	1636	2064	2485	2984				
		75.0									1171	1160	1462	1677	2114	2666				
		85.0									1083	1072	1351	1550	1954	2464				
		100.0									919	1158	1461	1843	2044	1860				
		125.0										929	1172	1478	1863	1695	2405			
		150.0											1121	1414	1783	1570	2228			
175.0												1387	1388	1388	1969	2088				
200.0													1050	1489	1564					
225.0														1358	1584	1677	2264			
250.0														1033	1205	1275	1722			
300.0															1158	1226	1655			
350.0																1066	1439			
400.0																	912	1231		

CONVERSION TABLE

FLOW RATE

US-GPM	lps	lpm	m ³ /h	ft ³ /h	ft ³ /min	imp - GPM	US - barrel / day
1	0.063	3.785	0.2271	8.0209	0.1337	0.833	34.286
15.850	1	60	3.6	127.133	2.1189	13.2	543.439
0.264	0.017	1	0.06	2.1189	0.0353	0.22	9.057
4.403	0.278	16.667	1	35.3147	0.5886	3.666	150.955
0.125	0.008	0.472	0.0283	1	0.0167	0.104	4.275
7.48	0.472	28.317	1.6990	60	1	6.229	256.475
1.201	0.076	4.546	0.2728	9.6326	0.1605	1	41.175
0.029	0.002	0.110	0.0066	0.2339	0.0039	0.024	1

LIQUID

US-Gallon	m ³	Litre (L)	Milliliter (ml)	Imp. Gallon	ft ³
1	0.00378	3.785	3785	0.8327	0.1337
264.2	1	1000	1X10 ³	220	35.3147
0.2642	0.001	1	1000	0.22	0.0353
2.642X10 ⁻⁴	1X10 ⁻⁵	0.001	1	2.2X10 ⁻⁴	3.53X10 ⁻⁵
1.201	0.00455	4.546	4546	1	0.1605
7.4805	0.0283	28.317	28317	6.2288	1

LIQUID HEAD AND PRESSURE

Psi	N/m ² (Pa)	kPa	bar	Kgf/cm ²	foot for water ft H ₂ O	Meter of water m H ₂ O	Millimeter of Mercury mm Hg	Inch of Mercury in Hg
1	6895	6.895	0.069	0.0703	2.31	0.703	51.72	2.036
1.45X10 ⁻⁴	1	0.001	1X10 ⁻⁵	1.02X10 ⁻⁵	3.35X10 ⁻⁴	1.02X10 ⁻⁴	0.0075	2.95X10 ⁻⁴
0.145	1000	1	0.01	0.0102	0.335	0.102	7.5	0.295
14.5	1X10 ⁵	100	1	1.02	33.52	10.2	750.1	29.53
14.22	98.067	98.07	0.981	1	32.81	10	735.6	28.96
0.433	2984	2.984	0.030	0.0305	1	0.305	22.42	0.882
1.42	9789	9.789	0.098	0.1	3.28	1	73.42	2.891
0.019	133.3	0.133	0.0013	0.0014	0.045	0.014	1	0.039
0.491	3386	3.386	0.0338	0.0345	1.133	0.0345	25.4	1

LENGTH

Inch (in)	Millimeter (mm)	Centimeter (cm)	Meter (m)	Foot (ft)	Yard (yd)
1	25.4	2.54	0.0254	0.0833	0.0278
0.0394	1	0.10	0.001	0.0033	0.0011
0.3937	10	1	0.01	0.0328	0.0109
39.3701	1000	100	1	3.2808	1.0936
12	304.8	30.48	0.3048	1	0.3333
36	914.4	91.44	0.9144	3	1

MASS

1 kilometer = 1000 metre = 0.62137 mile; 1 mile = 1609.34 metre = 1.60934 kilometre

Pound (lb)	Kilogram (kg)	Hundred Weight (cwt)	Tonne (t)	Ton long (tn)	short Ton (sh tn)
1	0.454	0.0089	4.54x10 ⁻⁴	4.46x10 ⁻⁴	5.0x10 ⁻⁴
2.205	1	0.0197	0.001	9.84x10 ⁻⁴	0.0011
112	50.802	1	0.0508	0.05	0.056
2204.6	1000	19.684	1	0.9842	1.1023
2240	1016	20	1.0161	1	1.1020
2000	907.2	17.857	0.9072	0.8929	1

TEMPERATURE

To Convert From	To	Use Formula
Celsius, tC	Kelvin, tK	tK = tC + 273.15
Fahrenheit, tF	Kelvin, tK	tK = (tF + 459.67) / 1.8
Celsius, tC	Fahrenheit, tF	tF = 1.8 tC + 32
Fahrenheit, tF	Celsius, tC	tC = (tF - 32) / 1.8
Kelvin, tK	Celsius, tC	tC = tK - 273.15
Kelvin, tK	Fahrenheit, tF	tF = 1.8 tK - 459.67

NOTES

A series of 15 horizontal dotted lines spaced evenly down the page, providing a guide for writing notes.

W I N N I N G W A Y S

When you have a good thing going it is quite in the fitting of things that recognitions come our way. Several prestigious awards, which decorate our shelf, say it all. These rewards not only acknowledge our position as a leader in the water pump industry but also serve as reminders about what the customer expects from a winner. And we, as ever, have our ears perfectly tuned to customer expectations.



C.R.I. PUMPS (PVT) LIMITED

(International Division)

7/46-1, Keeranatham Road, Saravanampatty, Coimbatore - 641 035. India.

Phone : +91-422-3911610, 3911612. Fax : +91-422-3911600 e-mail : cri@criexports.com website: www.crigroups.com

C.R.I. PUMPS (FZE)

P.O. Box 7988, A4-12 SAIF-Zone, Sharjah, U.A.E.
Tel : +971-6-5573041 (3 Lines), Fax : +971-6-5573042
e-mail : criumps@eim.ae website : www.cripumps.ae

C.R.I. PUMPS S.A. (PTY) LIMITED

P.O. Box 6292, Halfway House, Midrand - 1685,
Johannesburg, South Africa.
Tel : +27-11-8058631 / 32 Fax : +27-11-8058630
e-mail : cri@criumps.co.za website : www.cripumps.co.za
Branch : Capetown : + 27-21-931 2516

C.R.I. POMPA SANAYİ VE TİCARET LİMİTED ŞİRKETİ

10032 Sk. No:12 A.O.S.B. 35620 Çiğli-İzmir-Türkiye.
Tel : +90-232-328 22 99 Fax : +90-232-328 23 33
E-mail: cri@cripompa.com Website: www.cripompa.com

C.R.I PUMPS (Shanghai) Co., Ltd.

Building 53 (No. 17), 588 Yindu Road,
Minhang District, Shanghai, China.
Tel : +86-21-54405082, Fax : +86-21-54405083
e-mail : cri@bombascri.com.cn website : www.bombascri.com.cn

C.R.I. BOMBAS HIDRÁULICAS LTDA

Av. Rodrigo Fernando Grillo, 457, Jd. Manacas,
CEP - 14.801-534, Araraquara - SP, Brasil.
Fone : +55-16-3331 1099, Fax +55-16-3331 5344
e-mail : cri@cribombas.com.br website : www.cribombas.com.br
Filial : Jaboatão dos Guararapes-PE, Brasil.
Fone : (81) 3093-9620, Fax : (81) 3093-9600.

BOMBAS C.R.I. ESPAÑA,S.L.

Poligono Industrail El.Bony Calle 31, No.137, 46470
Catarroja (Valencia) Spain.
Tel: +34-96 1842 974 Fax: +34-96 1842 977.
Email: cri@bombascri.es Website: www.bombascri.es



<https://www.youtube.com/user/cripumpsglobal>



<https://www.facebook.com/criglobal>

