



Equipos
de Bombeo

Barmesa®

¡Líderes en Calidad!



Serie
BMV/BMVF

Bomba y motor estándar	01
Aplicaciones y condiciones de operación	01
Nomenclatura	02
Cobertura hidráulica	03
NPSH	04
Operación en paralelo	04
Presión máxima de trabajo	05
Temperatura ambiente máxima	05
Materiales de construcción	06
Curva de rendimiento BMV(F)1	08
Curva de rendimiento BMV(F)2	09
Curva de rendimiento BMV(F)3	10
Curva de rendimiento BMV(F)4	11
Curva de rendimiento BMV(F)8	12
Curva de rendimiento BMVF10	13
Curva de rendimiento BMV(F)12	14
Curva de rendimiento BMVF15	15
Curva de rendimiento BMV(F)16	16
Curva de rendimiento BMV(F)20	17
Curva de rendimiento BMV(F)32	18
Curva de rendimiento BMV(F)42	19
Curva de rendimiento BMV(F)65	20
Curva de rendimiento BMVF90	21
Curva de rendimiento BMVF120	22
Curva de rendimiento BMVF150	23
Curva de rendimiento BMVF200	24

Bomba

La bomba multietapas vertical es impulsada por un motor eléctrico estándar. La flecha del motor se conecta directamente con la flecha de la bomba a través de un acoplamiento. Los componentes del cilindro y el paso de flujo son resistentes a la presión y están fijados entre el cabezal de la bomba y la entrada y salida de la sección con pernos de anclaje. La entrada y la salida se encuentran en la parte inferior de la bomba en el mismo nivel. Este tipo de bomba puede estar equipada con un protector inteligente para prevenir eficazmente su funcionamiento en seco, un desfase o una sobrecarga.

Motor estándar

- ▶ Totalmente cerrados con ventilador exterior.
- ▶ 2 polos, 3 fases, 60 Hz, 230 / 460 volts.
- ▶ Protección IP55.
- ▶ Aislamiento clase "F".

Condiciones de operación

- ▶ Líquido fino, limpio, no inflamable y no explosivo que no contenga gránulos ni fibras sólidos.
- ▶ Temperatura del líquido:
Temperatura normal: $-15^{\circ}\text{C} \sim +70^{\circ}\text{C}$
Agua caliente: $-15^{\circ}\text{C} \sim +105^{\circ}\text{C}$
- ▶ Temperatura ambiente: hasta $+40^{\circ}\text{C}$
- ▶ Altitud: hasta 1000 m

Aplicaciones

La bomba BMV(F) es una bomba vertical, la estructura de la tubería puede garantizar que las bombas se puedan instalar directamente en el sistema de tubería, con los diámetros de tubería iguales y la salida y la entrada al mismo nivel. Este diseño de estructura hace que la conexión de la bomba a la tubería sea más compacta. Tienen diferentes especificaciones y diferentes series, para cumplir con los requisitos de caudal y presión. Pueden transferir no solo agua sino también diversos líquidos para medios industriales, adecuados para diferentes temperaturas, caudales y rangos de presión. Las BMV(F) son adecuadas para líquidos no corrosivos y las BMV son adecuadas para líquidos corrosivos suaves.

Suministro de agua:

- ▶ Filtrado y transporte de agua.
- ▶ Partición de agua.
- ▶ Aumento de la presión neta para edificios de gran altura.
- ▶ Aumento de la presión del agua industrial.

Impulso industrial:

- ▶ Sistema de agua de proceso.
- ▶ Sistema de limpieza.
- ▶ Sistema de lavado a alta presión.
- ▶ Sistema contra incendios.
- ▶ Limpieza de automóviles.

Transporte de líquidos industriales:

- ▶ Sistema de refrigeración y aire acondicionado.
- ▶ Sistema de agua de alimentación de caldera.
- ▶ Sistema de temperatura, ajuste de máquinas.

Suministro:

- ▶ Aceite y alcohol.
- ▶ Ácido y álcali.
- ▶ Etileno, glicol y refrigerante.

Tratamiento del agua:

- ▶ Sistema de ultrafiltración.
- ▶ Sistema de ósmosis inversa.
- ▶ Sistema de destilación.

Riego:

- ▶ Riego por región.
- ▶ Riego por aspersion.
- ▶ Riego por goteo.

BMV(F)1, 2, 3, 4, 8, 10, 12, 15, 16, 20

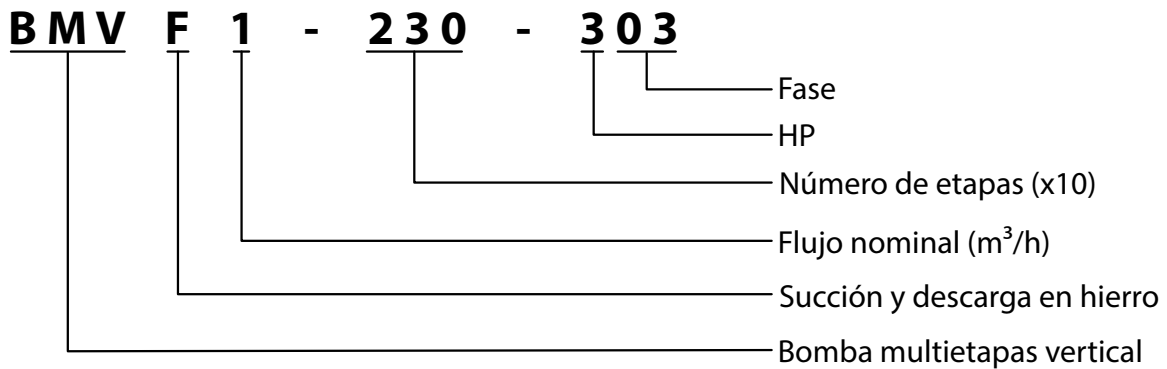

BMV(F)32, 42, 65, 90, 120, 150

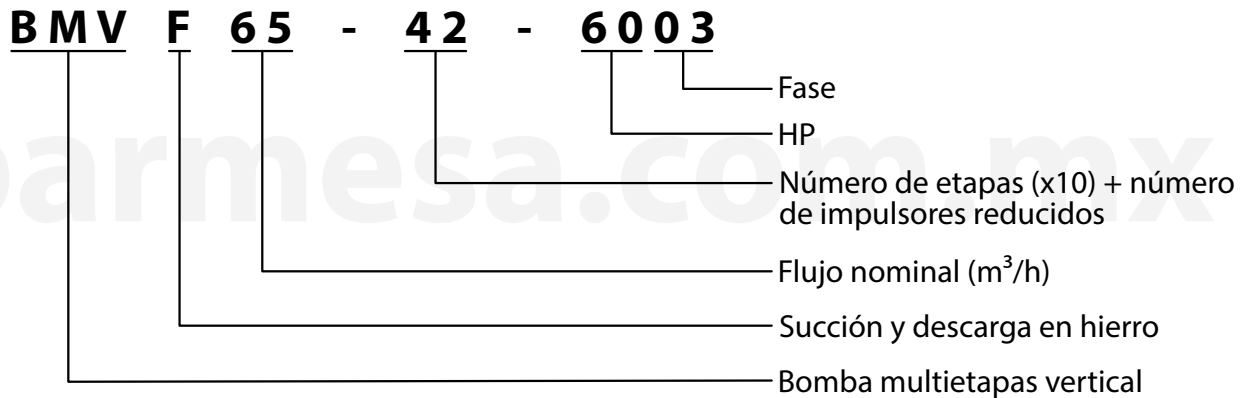

BMVF200

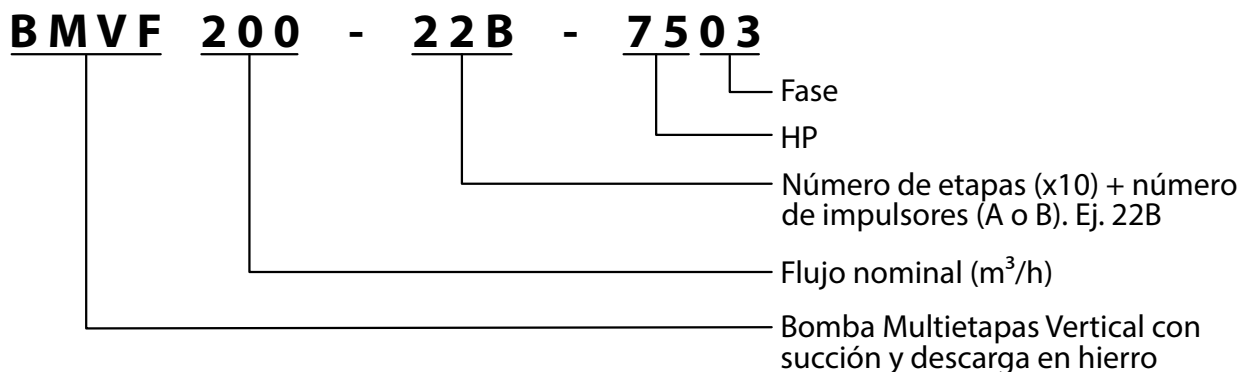

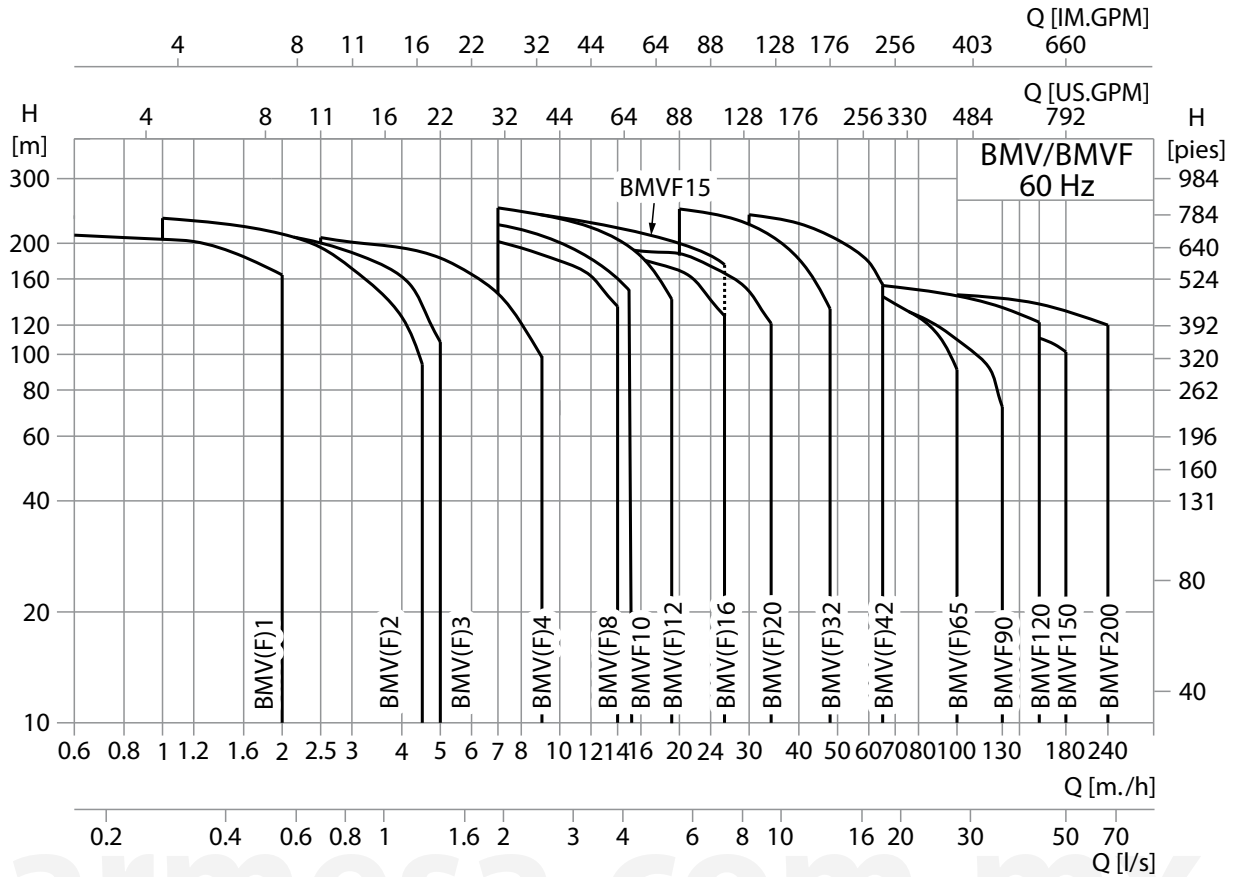

Especificaciones

PARÁMETRO	BMV(F)1	BMV(F)2	BMV(F)3	BMV(F)4	BMV(F)8	BMV(F)10	BMV(F)12	BMV(F)15	BMV(F)16
Flujo nominal [m ³ /h]	1	2	3	4	8	10	12	15	16
Flujo nominal [l/s]	0.28	0.56	0.83	1.1	2.2	2.8	3.3	4.1	4.4
Rango del ujo [m ³ /h]	0.6-2	1-4.5	1.5-5	2.5-8	7-14	7-15	7-19	9-26	10-26
Rango del ujo [l/s]	0.17-0.56	0.28-1.25	0.42-1.4	0.7-2.2	1.9-3.9	1.9-4.1	1.9-5.3	2.5-7.2	2.8-7.2
Presión máxima [bar]	22	23.5	23	21	20	25	25	24	20
Capacidad motor [kW]	0.37-3	0.55-4	0.37-4	0.75-5.5	0.75-11	1.5-11	1.1-15	1.5-18.5	2.2-18.5
Rango de temp. [°C]	-15~105								
Eficiencia máx. [%]	44	46	54	57	62	70	63	73	66
Brida	DN25	DN25	DN25	DN32	DN40	DN40	DN50	DN50	DN50

PARÁMETRO	BMV(F)20	BMV(F)32	BMV(F)42	BMV(F)65	BMV(F)90	BMV(F)120	BMV(F)150	BMV(F)200
Flujo nominal [m ³ /h]	20	32	42	65	90	120	150	200
Flujo nominal [l/s]	5.6	8.9	12.5	17.8	25	33	41.6	55.6
Rango del ujo [m ³ /h]	12-34	20-48	30-65	40-100	60-130	60-160	80-180	100-240
Rango del ujo [l/s]	3.3-9.4	5.5-13.3	8.3-18	11.1-27.7	16.7-36.1	16.7-44.4	22-50	27.8-66.7
Presión máxima [bar]	20	25	26	18	15	15	14	15
Capacidad motor [kW]	2.2-18.5	3-30	5.5-45	7.5-45	11-45	18.5-75	15-75	30-110
Rango de temp. [°C]	-15~105							
Eficiencia máx. [%]	69	73	75	76	77	74	73	78
Brida	DN50	DN65	DN80	DN100	DN100	DN125	DN125	DN150

NPSH y operación en paralelo

Presión mínima de entrada NPSH

En caso de que la presión en la bomba sea inferior a la presión de vapor utilizada para evitar cavitaciones, se debe garantizar una presión mínima en el lado de entrada de la bomba. La succión máxima se puede calcular con la siguiente fórmula:

$$H = P_b \times 10.2 - NPSH - H_f - H_v - H_s$$

P_b = presión atmosférica [bar]
(se puede ajustar a 1 bar)

En un sistema cerrado, P_b significa presión del sistema [bar].

NPSH = carga de succión neta positiva [m] (si se puede leer desde el punto de posible caudal máximo mostrado en la curva NPSH).

H_f = pérdida en la tubería de succión [m].

H_v = presión de vapor [m].

H_s = margen seguro = cabezal de entrega mínima de 0.5 m.

Si el resultado calculado H es positivo, la bomba puede funcionar bajo la máxima altura de succión H.

En caso de que el resultado calculado H sea negativo, es necesario una presión mínima de entrada.

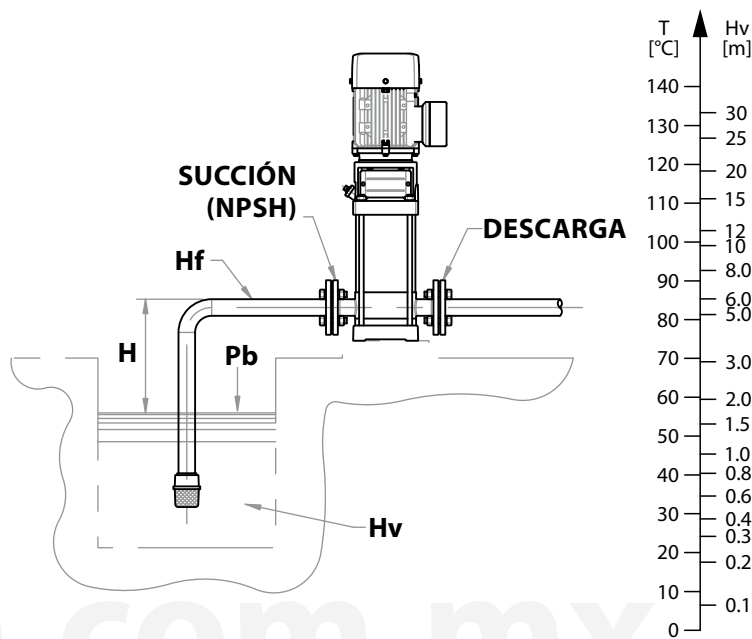

Compruebe y asegúrese de que la bomba no esté en estado de cavitación.

Operación en paralelo

La conexión de varias bombas en funcionamiento paralelo beneficiará más que la ejecución de una sola bomba grande.

- ▶ Aplicable a diferentes estados de trabajo necesarios en un sistema de flujo variable.
- ▶ Aumento de la posibilidad de suministro de agua cuando la bomba falla. Porque en caso de fallo de la bomba, solo se afecta parte del flujo del sistema.

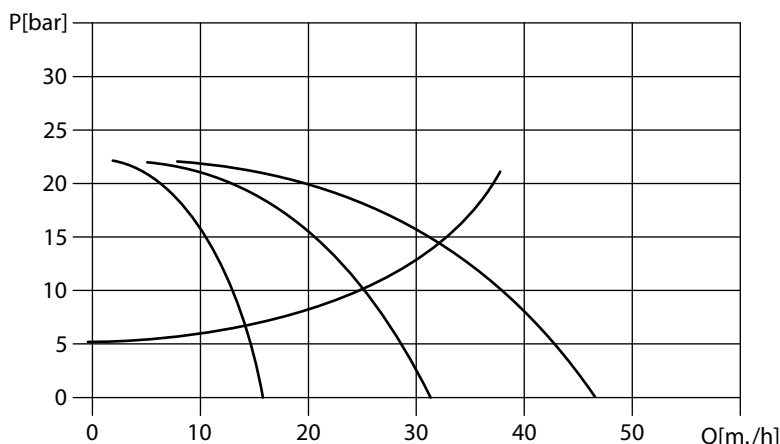

Se pueden conectar dos bombas o más en paralelo si es necesario.

Presión y temperatura máxima

Presión máxima de trabajo

La siguiente curva muestra la limitación de la presión y la temperatura, que deben estar en el alcance como se muestra en la curva.

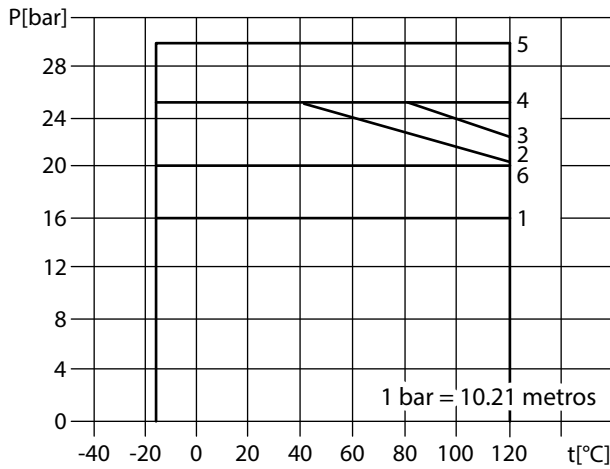

MODELO	NÚMERO DE CURVA
BMV(F)1, 2, 3 y 4	2
BMV(F)8, 10, 12, 15, 16 y 20	3
BMV(F)32	
32-32, 42 y 52	1
32-60 y 82	4
32-90	5
BMV(F)42	
42-20 y 30	1
42-42, 40, 50 y 60	4
42-70	5
BMV(F)65	
65-20 y 30	1
65-42 y 52	4
BMVF90	
90-20 y 31	1
90-42	4
BMVF120, 150 y 200	6

barmesa.com.mx

Temperatura ambiente máxima

Cuando la bomba funciona a una temperatura ambiente superior a 40 °C o a una altitud superior a 1000 m, debido a la baja densidad del aire y los malos efectos de enfriamiento, la potencia de salida del motor P2 se reducirá en cierta medida. Si la bomba funciona en las condiciones mencionadas anteriormente, debe estar equipada con un motor de mayor potencia.

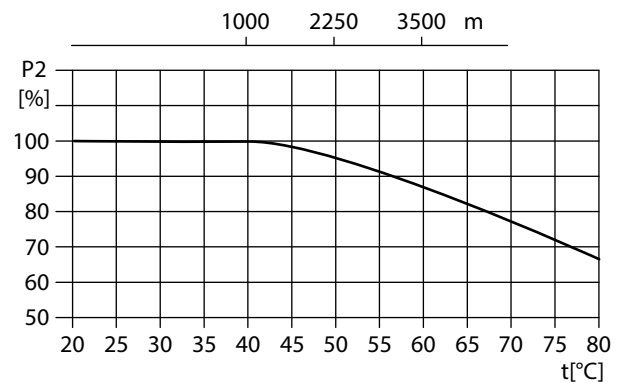

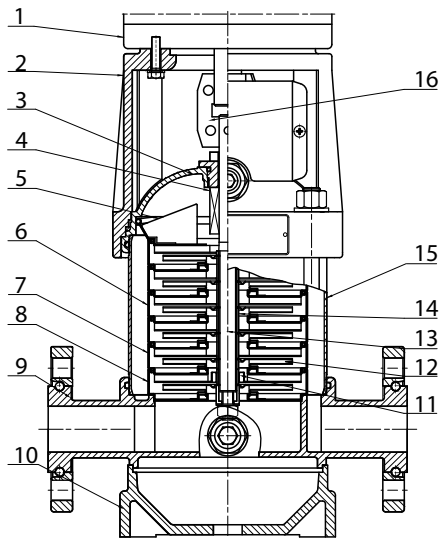

BMV1, 2, 3 y 4

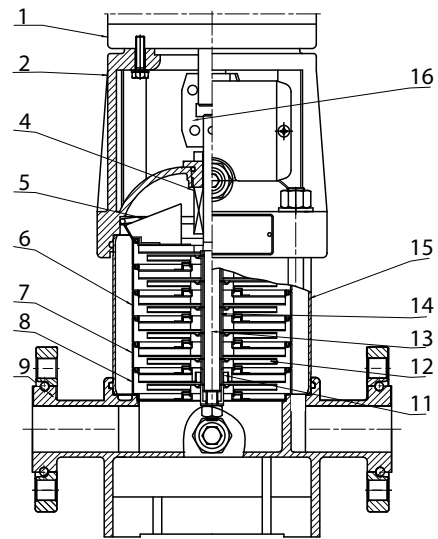

BMVF1, 2, 3 y 4

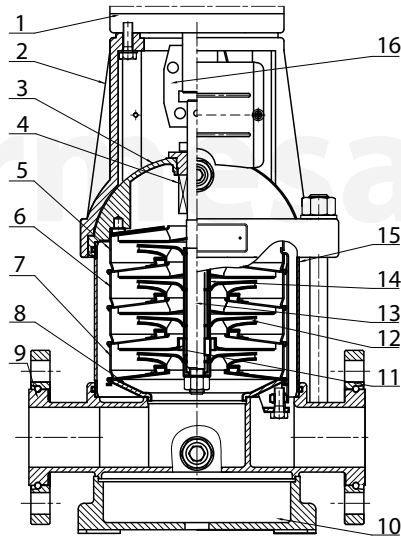

BMV8, 10, 12, 15, 16 y 20

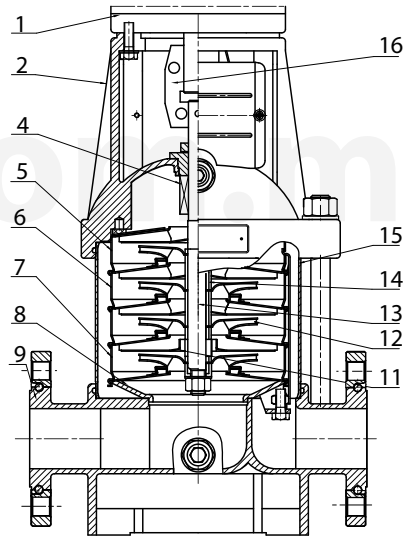

BMVF8, 10, 12, 15, 16 y 20

Materiales para BMV(F)1, 2, 3, 4, 8, 10, 12, 15, 16 y 20

ITEM	DESCRIPCIÓN	MATERIAL	DESIGNACIÓN
1	Motor		
2	Cabezal de la bomba	Hierro gris	ASTM 25B
4	Sello mecánico		
5	Difusor superior	Acero inox.	AISI 304
6	Difusor	Acero inox.	AISI 304
7	Soporte de difusor	Acero inox.	AISI 304
8	Inductor	Acero inox.	AISI 304
11	Balero	Carburo de tungsteno	
12	Impulsor	Acero inox.	AISI 304
13	Flecha	Acero inox.	AISI 304/16L

ITEM	DESCRIPCIÓN	MATERIAL	DESIGNACIÓN
14	Manguito	Acero inox.	AISI 304
15	Cilindro	Acero inox.	AISI 304
16	Acoplamiento	Acero al carbón	
BMV			
3	Sello de la base	Acero inox.	AISI 304
9	Cámara de succión y descarga	Acero inox.	AISI 304
10	Placa base	Hierro gris	ASTM 25B
BMVF			
9	Cámara de succión y descarga	Hierro gris	ASTM 25B

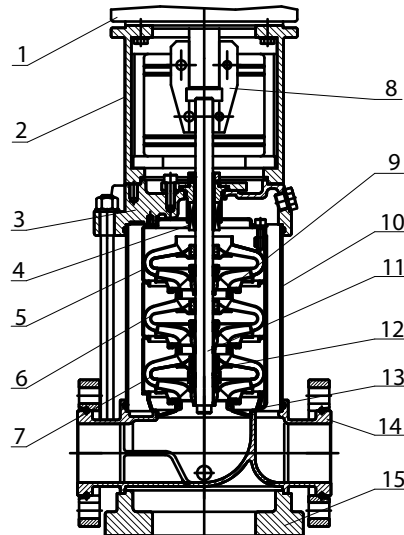

BMV32, 42 y 65

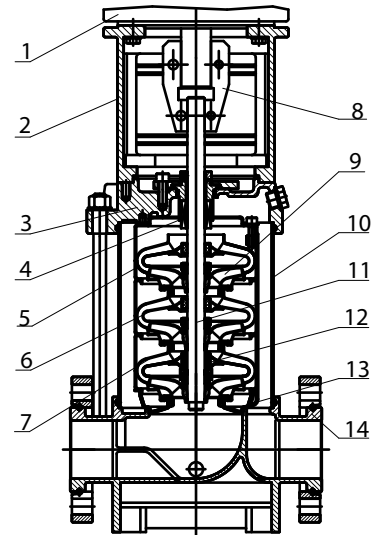

BMVF32, 42, 65 y 90

Materiales para BMV(F)32, 42, 65 y 90

ITEM	DESCRIPCIÓN	MATERIAL	DESIGNACIÓN
1	Motor		
2	Soporte	Hierro gris / Hierro dúctil	ASTM25B ASTM70-50-05
4	Sello mecánico		
5	Difusor superior	Acero inox.	AISI 304
6	Difusor	Acero inox.	AISI 304
7	Soporte de difusor	Acero inox.	AISI 304
8	Acoplamiento	Hierro dúctil	ASTM70-50-05
9	Impulsor	Acero inox.	AISI 304
10	Cilindro	Acero inox.	AISI 304
11	Flecha	Acero inox.	AISI 304/16L

ITEM	DESCRIPCIÓN	MATERIAL	DESIGNACIÓN
12	Balero	Carburo de tungsteno	
13	Inductor	Acero inox.	AISI 304
BMV			
3	Cabezal de la bomba	Acero inox.	AISI 304
14	Cámara de succión y descarga	Acero inox.	AISI 304
15	Base	Hierro gris	ASTM 25B
BMVF			
3	Cabezal de la bomba	Hierro gris / Hierro dúctil	ASTM25B ASTM70-50-05
14	Cámara de succión y descarga	Hierro gris / Hierro dúctil	ASTM25B ASTM70-50-05

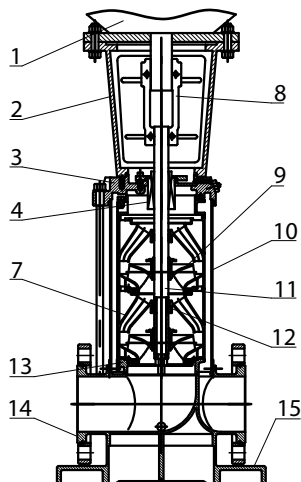

BMVF120, 150 y 200

Materiales para BMVF120, 150 y 200

ITEM	DESCRIPCIÓN	MATERIAL	DESIGNACIÓN
1	Motor		
2	Soporte	Hierro gris / Hierro dúctil	ASTM25B ASTM70-50-05
3	Cabezal de la bomba	Hierro gris / Hierro dúctil	ASTM25B ASTM70-50-05
4	Sello mecánico		
7	Difusor superior	Acero inox.	AISI 304
8	Acoplamiento	Hierro dúctil	ASTM70-50-05
9	Impulsor	Acero inox.	AISI 304
10	Cilindro	Acero inox.	AISI 304
11	Flecha	Acero inox.	AISI 304/16L
12	Balero	Carburo de tungsteno	
13	Inductor	Acero inox.	AISI 304
14	Cámara de succión y descarga	Hierro gris / Hierro dúctil	ASTM25B ASTM70-50-05

Curva de rendimiento BMV(F)1

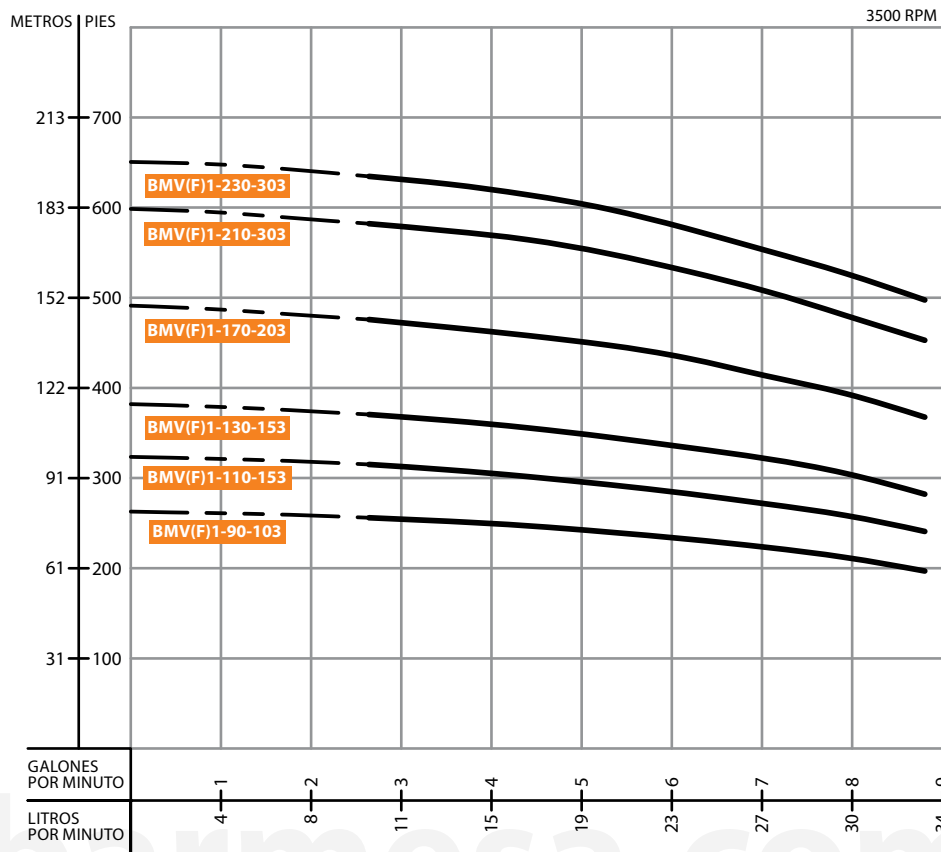

Dibujo de Instalación (mm)



Tabla de Rendimiento

MODELO	PASOS	HP	Q (LPM)	10	13.3	16.7	20	23.3	26.7	30	33.3
BMV(F)1-90-103	9	1	H (m)	76	75	74	73	71	66	64	60
BMV(F)1-110-153	11	1.5		95	93	90	87	85	81	78	73
BMV(F)1-130-153	13	1.5		112	110	107	105	100	95	93	86
BMV(F)1-170-203	17	2		144	141	139	137	132	124	120	112
BMV(F)1-210-303	21	3		177	174	172	168	162	153	147	138
BMV(F)1-230-303	23	3		193	190	188	184	174	167	161	152

Dimensiones y Pesos

TAMAÑO (mm)	PESO (kg)				
	B1	B2	B1+B2	D1	D2
394	245	639	170	142	28
430	245	675	170	142	29
466	245	711	170	142	31
548	290	838	190	155	38
620	290	910	190	155	42
656	290	946	190	155	43

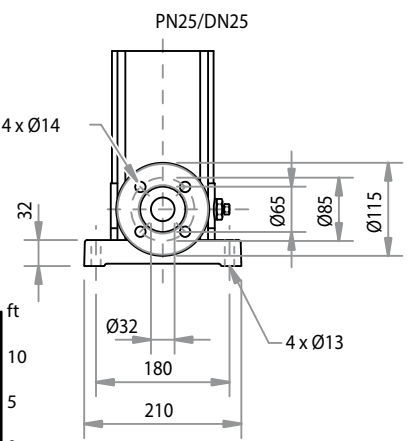
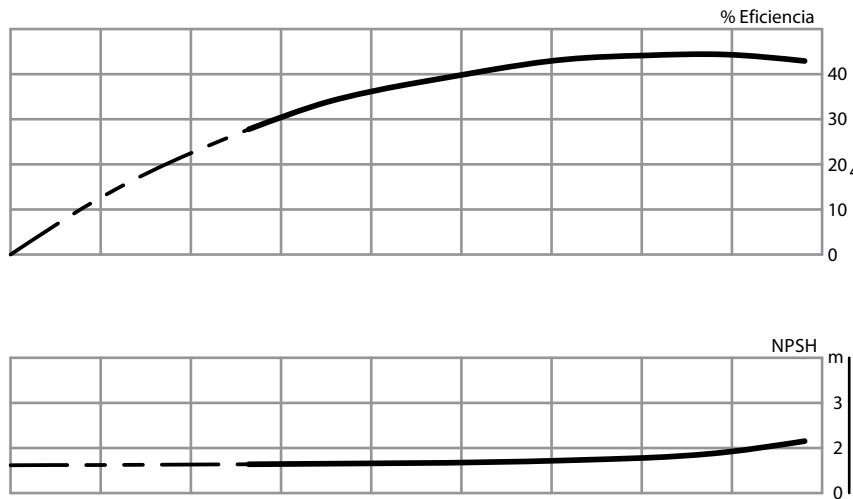
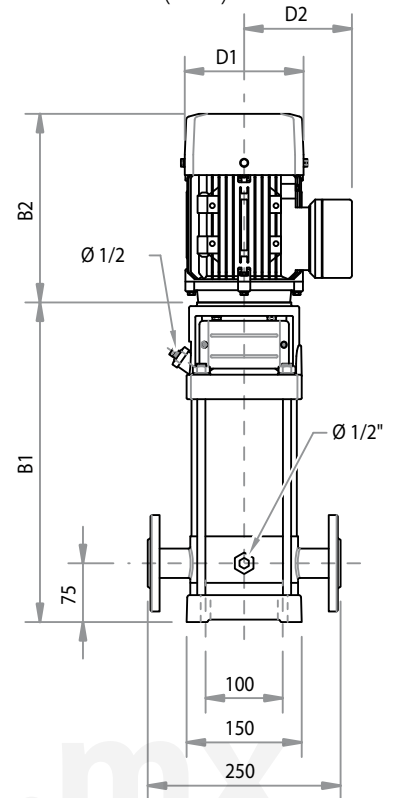
Curva de rendimiento BMV(F)2

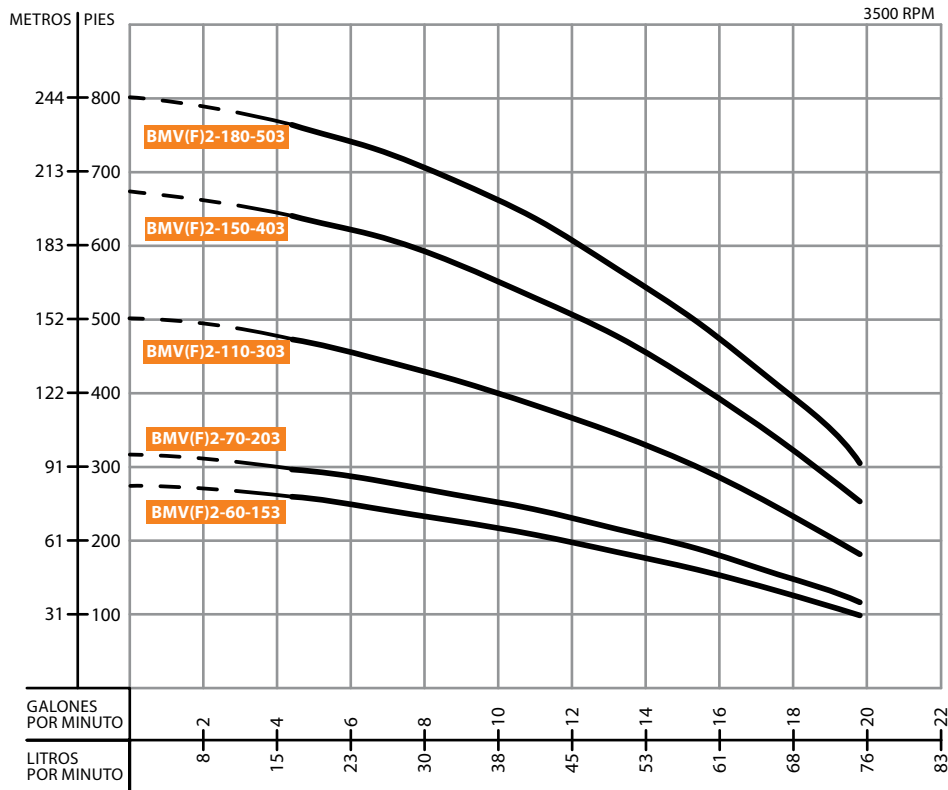

Dibujo de Instalación (mm)



Tabla de Rendimiento

MODELO	PASOS	HP	Q (LPM)	16.7	25	33.3	41.7	50	58.3	66.7	75
BMV(F)2-60-153	6	1.5	H (m)	78	74	69	63	56	49	40	30
BMV(F)2-70-203	7	2		91	86	81	74	66	57	47	35
BMV(F)2-110-303	11	3		143	136	128	116	104	90	75	56
BMV(F)2-150-403	15	4		195	186	176	160	142	125	103	77
BMV(F)2-180-503	18	5.5		234	228	212	195	171	151	126	94

Dimensiones y Pesos

TAMAÑO (mm)	TAMAÑO (mm)					PESO (kg)
	B1	B2	B1+B2	D1	D2	
60-153	340	245	585	170	142	26
70-203	368	290	658	190	155	32
110-303	440	290	730	190	155	37
150-403	522	315	837	197	165	45
180-503	576	335	911	230	188	54

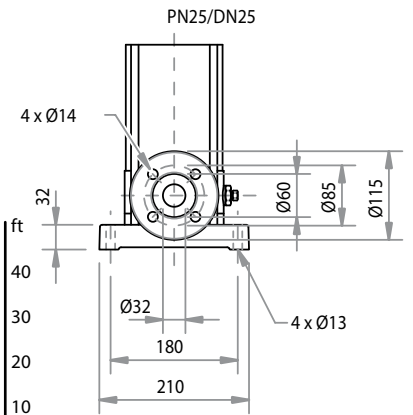
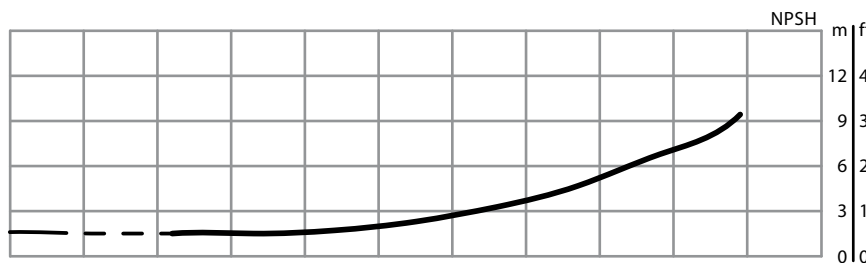
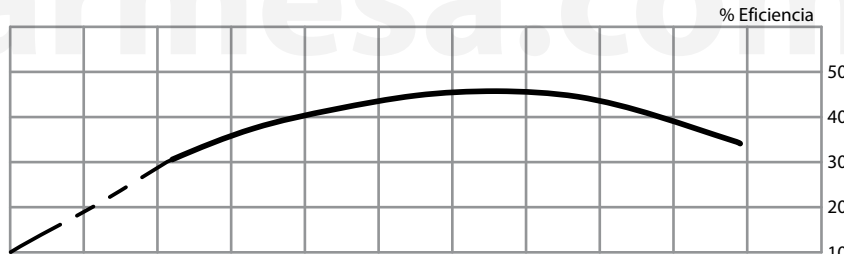
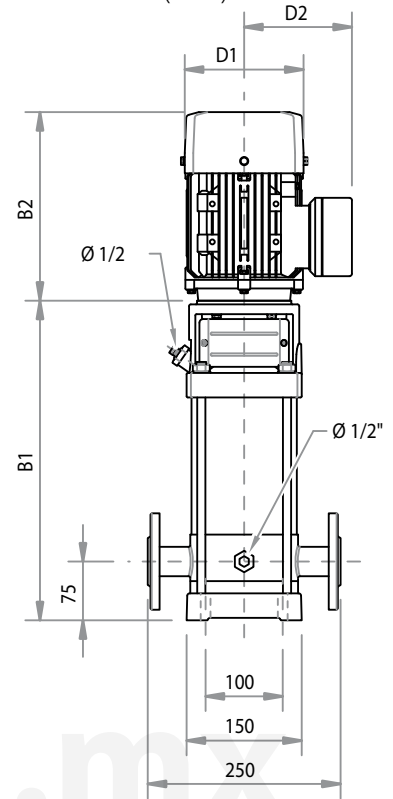
Curva de rendimiento BMV(F)3

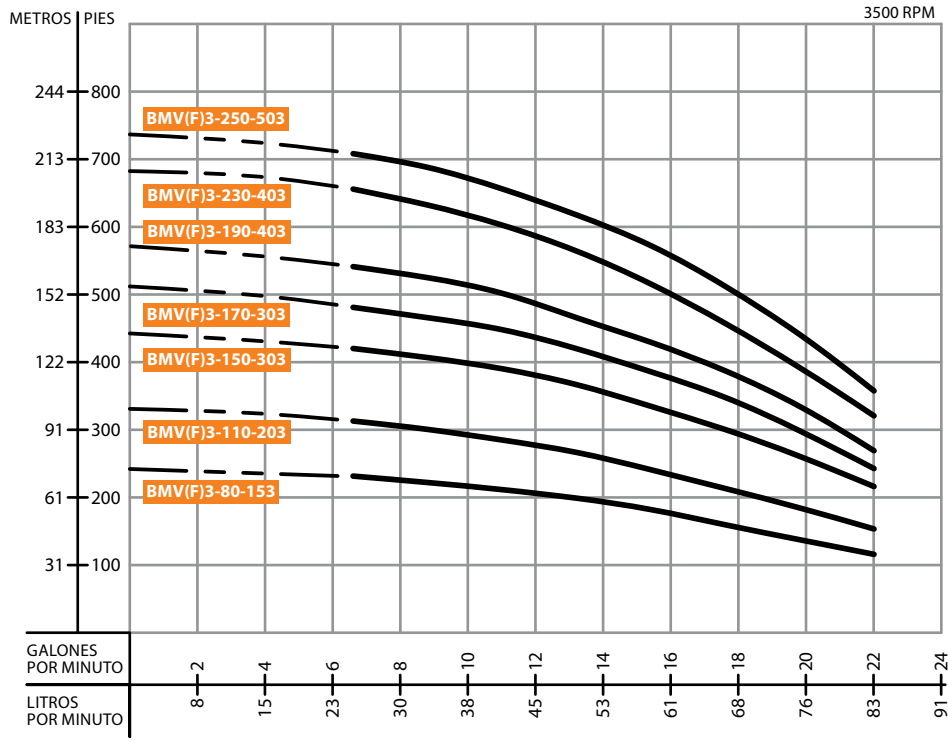

Dibujo de Instalación (mm)



Tabla de Rendimiento

MODELO	PASOS	HP	Q (LPM)	25	33.3	41.7	50	58.3	66.7	75	83.3
BMV(F)3-80-153	8	1.5	H (m)	70	67	64	61	53	49	44	35
BMV(F)3-110-203	11	2		96	92	87	82	74	69	59	48
BMV(F)3-150-303	15	3		129	126	120	112	99	93	81	65
BMV(F)3-170-303	17	3		147	143	137	128	114	106	91	74
BMV(F)3-190-403	19	4		165	160	153	142	123	118	102	82
BMV(F)3-230-403	23	4		200	194	185	174	154	142	122	98
BMV(F)3-250-503	25	5.5		217	211	202	187	167	154	134	108

Dimensiones y Pesos

B1	TAMAÑO (mm)				PESO (kg)
	B2	B1+B2	D1	D2	
376	245	621	170	142	27
440	290	730	190	155	34
512	290	802	190	155	39
548	290	838	190	155	40
594	315	909	197	165	48
666	315	981	197	165	50
702	335	1037	230	188	58

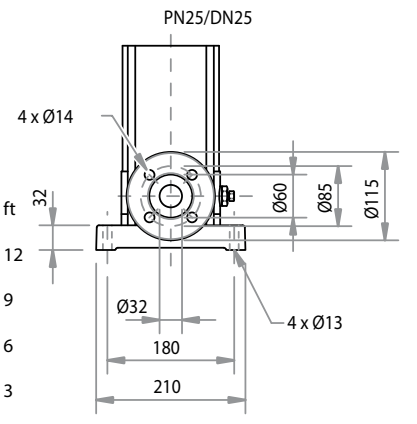
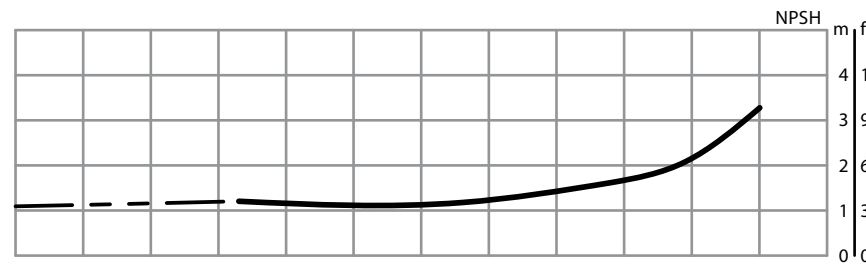
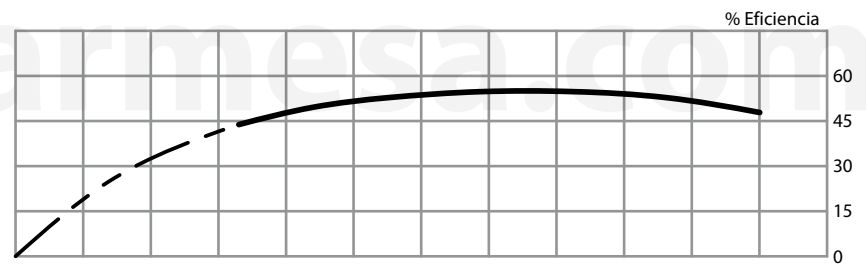
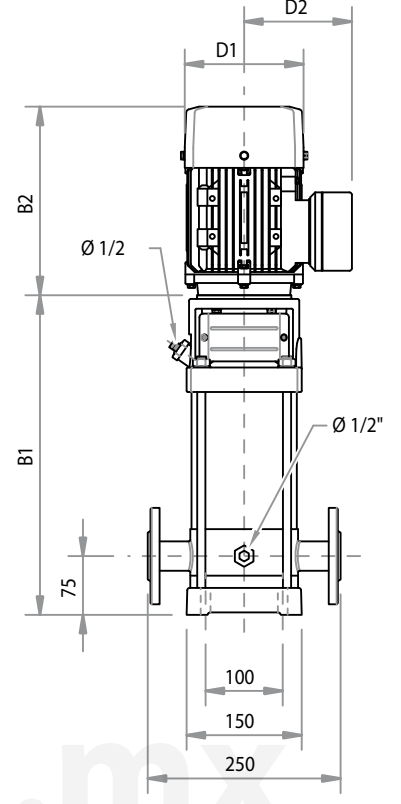
Curva de rendimiento BMV(F)4

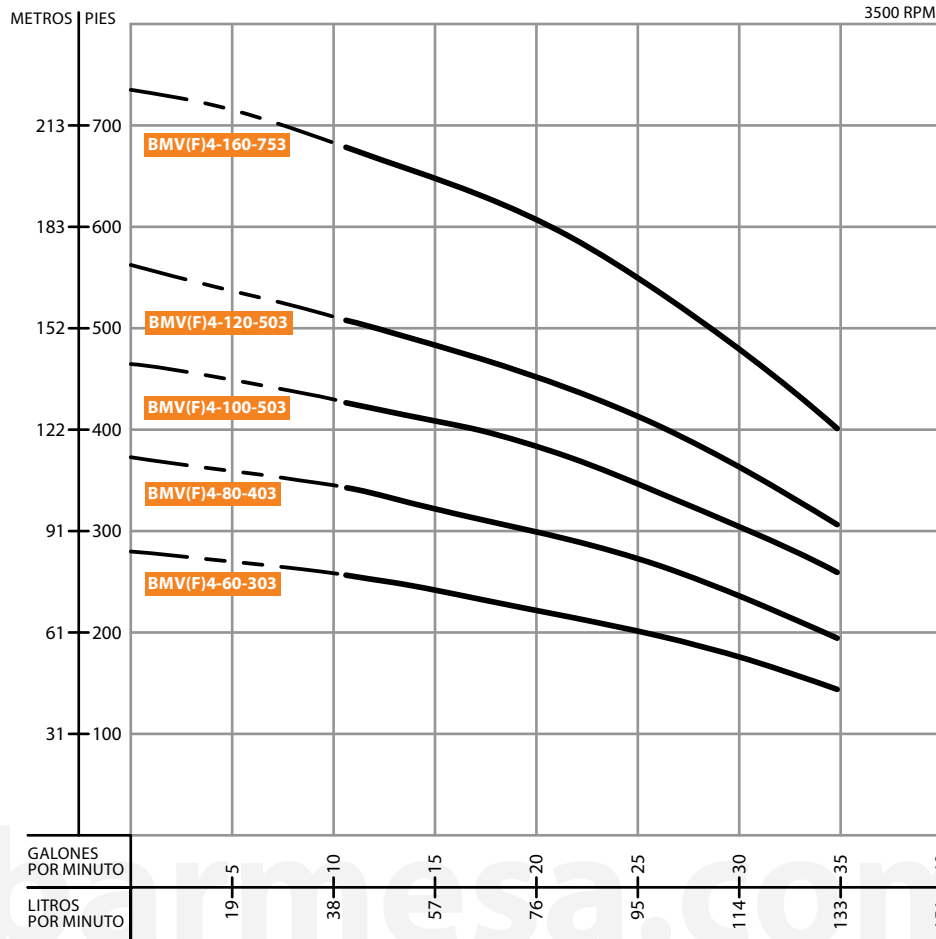

Dibujo de Instalación (mm)



Tabla de Rendimiento

MODELO	PASOS	HP	Q (LPM)	41.7	50	66.7	83.3	100	116.7	133.3
BMV(F)4-60-303	6	3	H (m)	78	75	72	67	59	54	47
BMV(F)4-80-403	8	4		104	100	95	90	79	72	63
BMV(F)4-100-503	10	5.5		130	125	120	113	102	90	80
BMV(F)4-120-503	12	5.5		156	150	145	136	122	109	96
BMV(F)4-160-753	16	7.5		207	201	196	183	165	146	128

Dimensiones y Pesos

TAMAÑO (mm)	TAMAÑO (mm)					PESO (kg)
	B1	B2	B1+B2	D1	D2	
60-303	404	290	694	190	155	35
80-403	468	345	813	197	165	42
100-503	522	335	857	230	188	51
120-503	576	335	911	230	188	52
160-753	704	430	1134	260	208	66

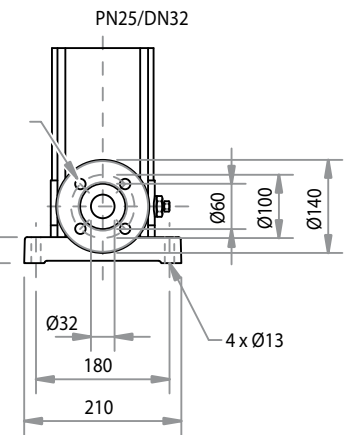
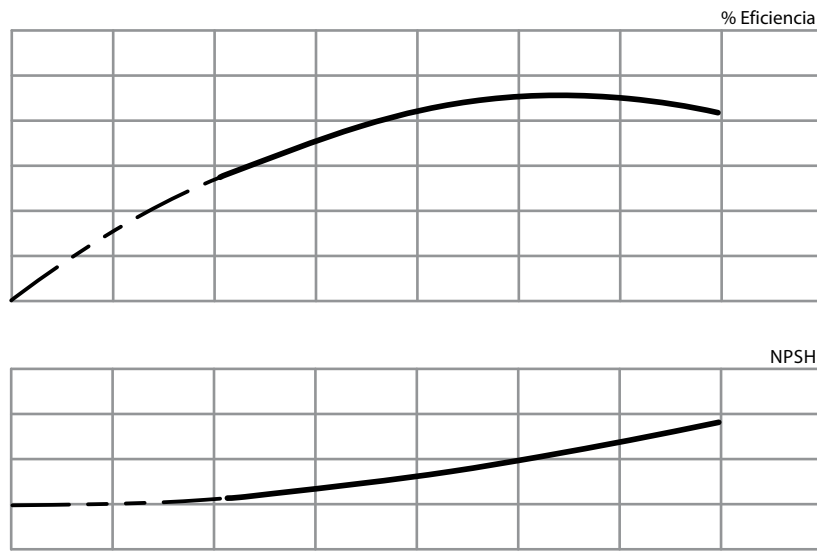
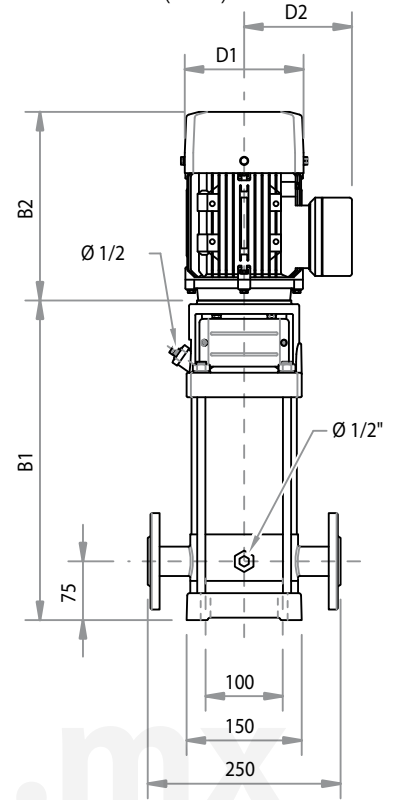
Curva de rendimiento BMV(F)8

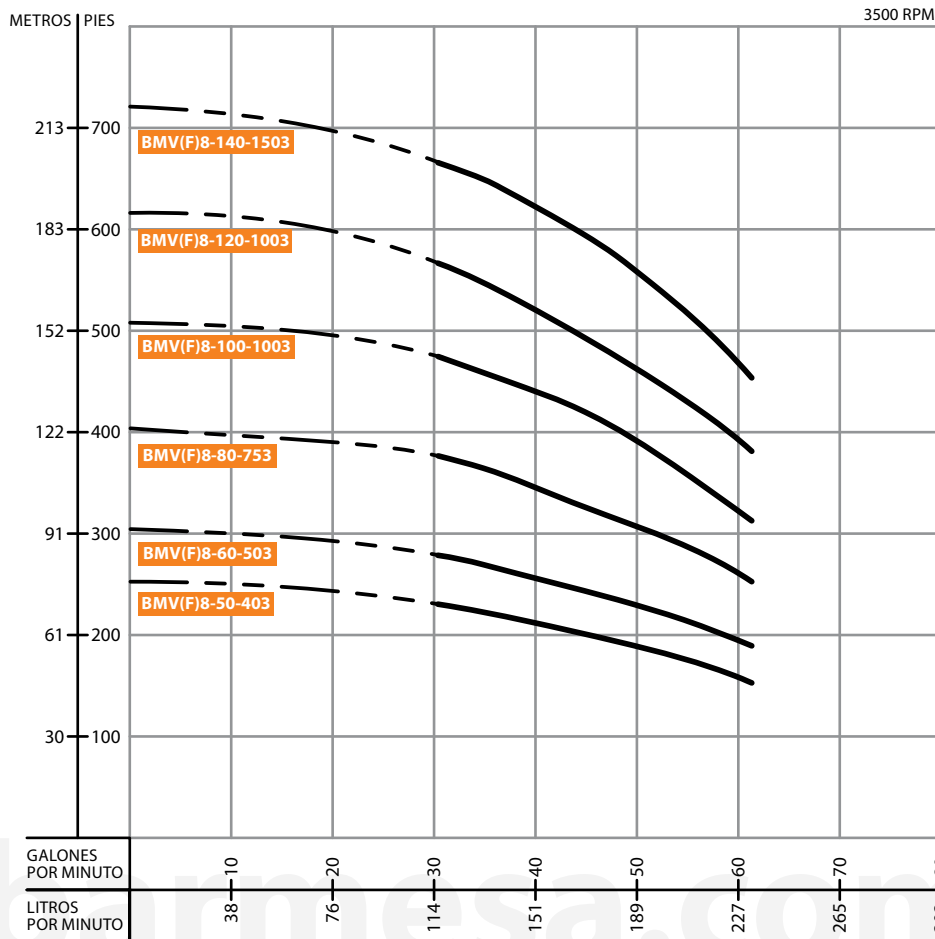

Dibujo de Instalación (mm)



Tabla de Rendimiento

MODELO	PASOS	HP	Q (LPM)	116.7	133.3	150	166.7	183.3	200	216.7	233.3
BMV(F)8-50-403	5	4	H (m)	70	68	65	63	59	56	52	47
BMV(F)8-60-503	6	5.5		85	82	78	76	72	68	62	57
BMV(F)8-80-753	8	7.5		115	110	105	101	97	91	84	75
BMV(F)8-100-1003	10	10		145	140	132	126	122	115	105	95
BMV(F)8-120-1003	12	10		173	167	160	152	147	132	125	115
BMV(F)8-140-1503	14	15		202	195	188	179	174	163	147	135

Dimensiones y Pesos

TAMAÑO (mm)					PESO (kg)
B1	B2	B1+B2	D1	D2	
457	315	772	197	165	50
487	335	822	230	188	58
567	430	997	260	208	71
627	430	1057	260	208	80
687	430	1117	260	208	82
835	490	1325	330	255	153

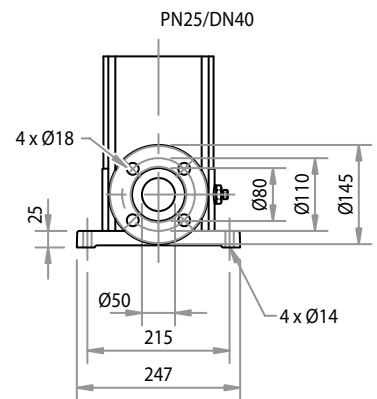
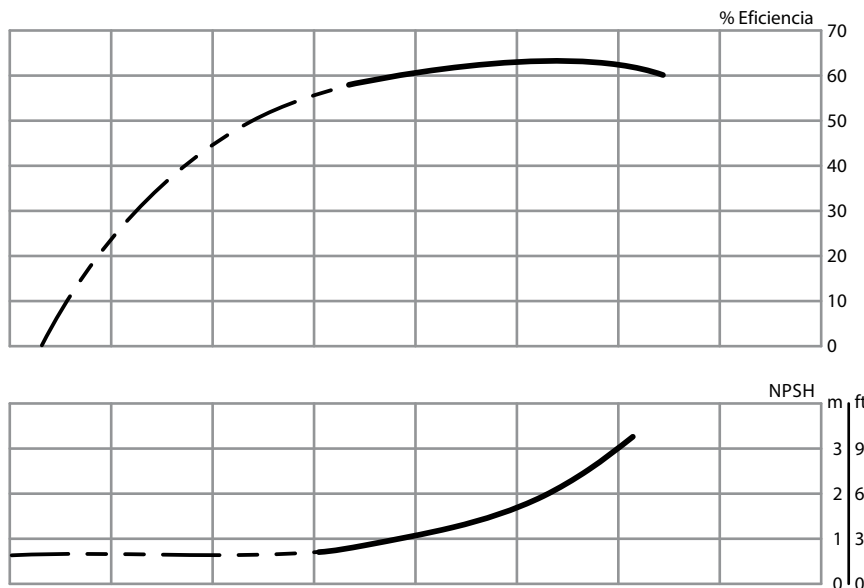
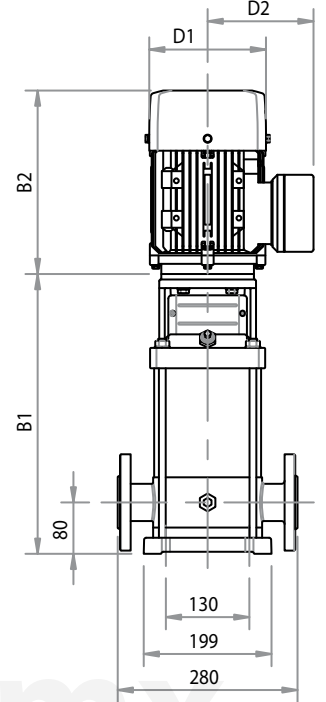
Curva de rendimiento BMVF10

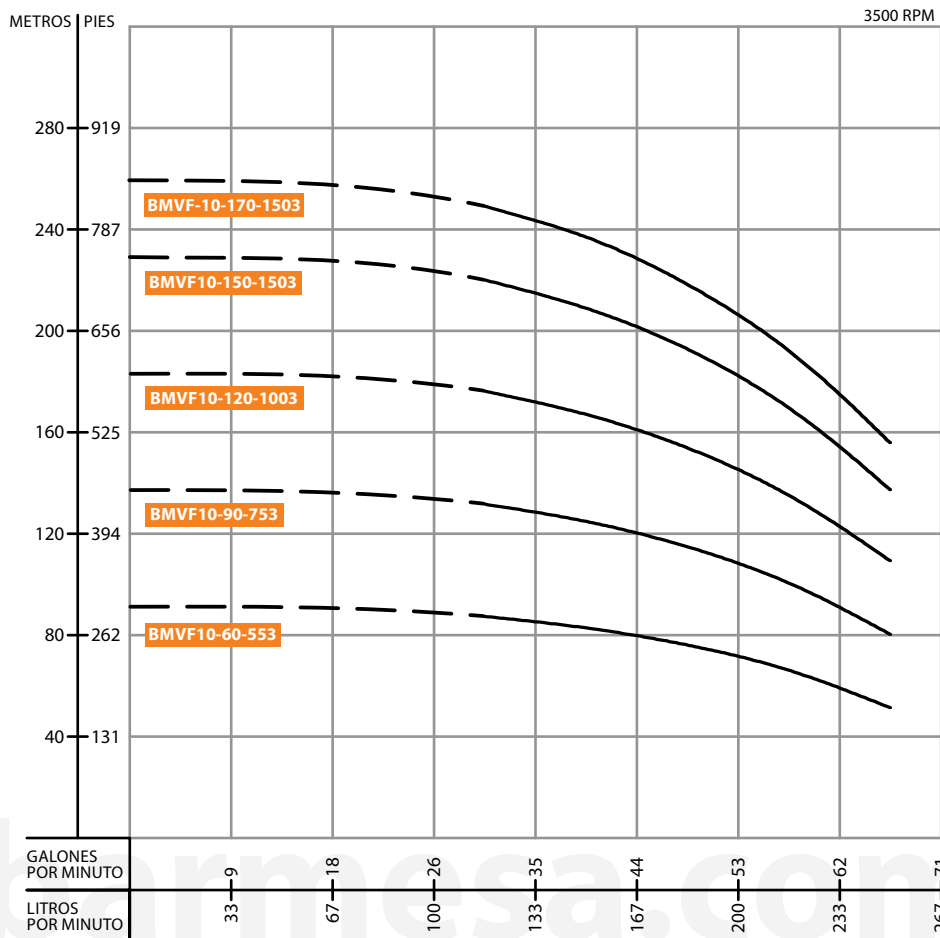

Dibujo de Instalación (mm)



Tabla de Rendimiento

MODELO	PASOS	HP	Q (LPM)	116.7	150	166.7	183.3	200	216.7	250
BMVF10-60-553	6	6	H (m)	87.5	83	80	76	71.5	66.5	51.5
BMVF10-90-753	9	7.5		132	125	120.5	115	108	101	80.5
BMVF10-120-1003	12	10		176.5	167	161	154	144	135.5	109.5
BMVF10-150-1503	15	15		220.5	209	202	193	180	170	137.5
BMVF10-170-1503	17	15		249.5	237	229	218.5	204	192.5	156

Dimensiones y Pesos

B1	B2	B1+B2	TAMAÑO (mm)		PESO (kg)
			D1	D2	
487	360	847	230	185	59
597	400	997	260	210	77
687	400	1087	260	210	88
865	510	1375	330	255	143
925	510	1435	330	255	144

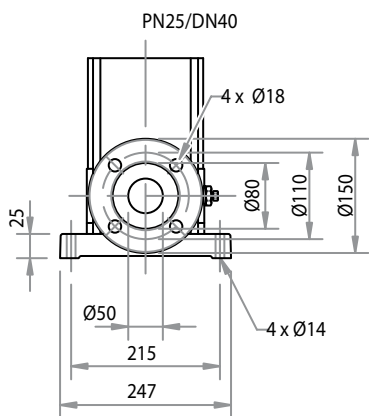
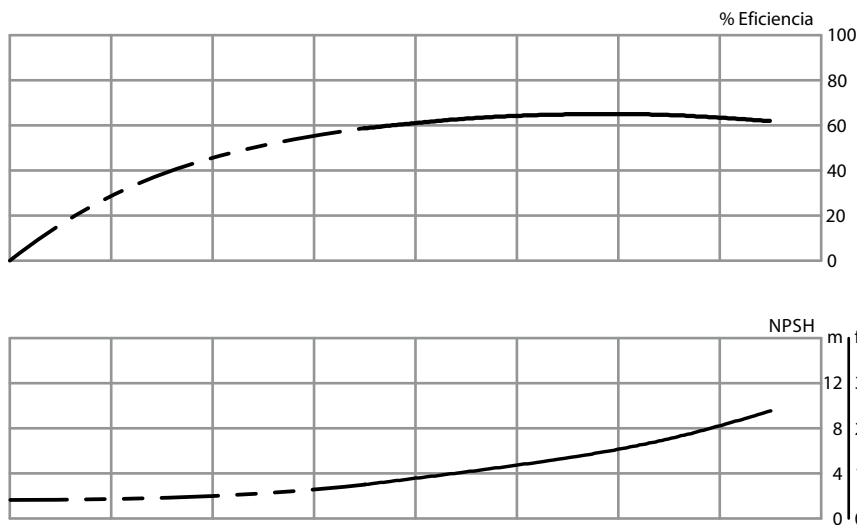
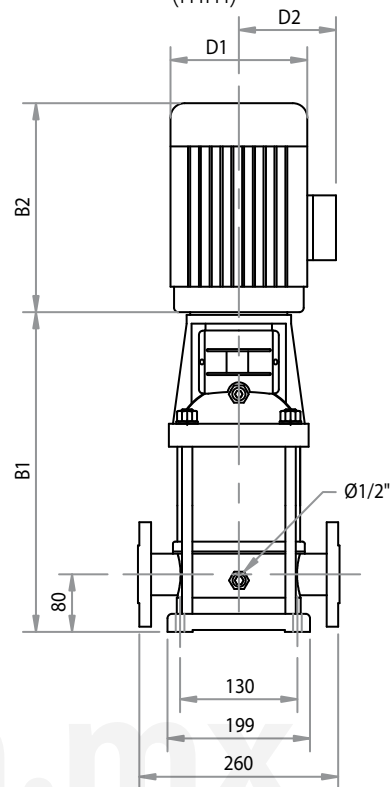
Curva de rendimiento BMV(F)12



Tabla de Rendimiento

MODELO	PASOS	HP	Q (LPM)	116.7	150	183.3	200	216.7	250	283.3	316.7
BMV(F)12-20-303	2	3	H (m)	35	34	32.5	32	30.5	27	24.5	20.5
BMV(F)12-30-503	3	5.5		52.5	51.5	50	48	46	41.5	37.5	31
BMV(F)12-50-753	5	7.5		88	86	82	80	77	70	62	51
BMV(F)12-70-1003	7	10		124	121	116	112	107	97	88	71
BMV(F)12-100-1503	10	15		178	173	166	161	153	140	128	104
BMV(F)12-140-2003	14	20		249	242	233	225	216	198	180	145

Dimensiones y Pesos

B1	TAMAÑO (mm)					PESO (kg)
	B2	B1+B2	D1	D2		
367	290	657	190	155	41	
407	335	742	230	188	56	
487	430	917	260	208	71	
547	430	977	260	208	78	
725	490	1215	330	255	151	
845	490	1335	330	255	167	

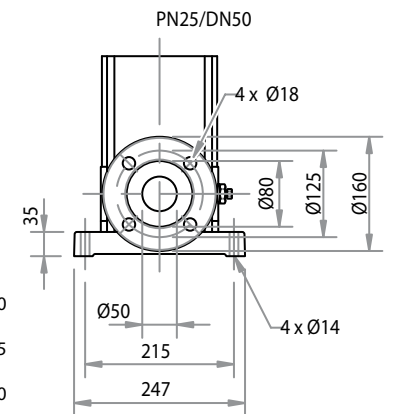
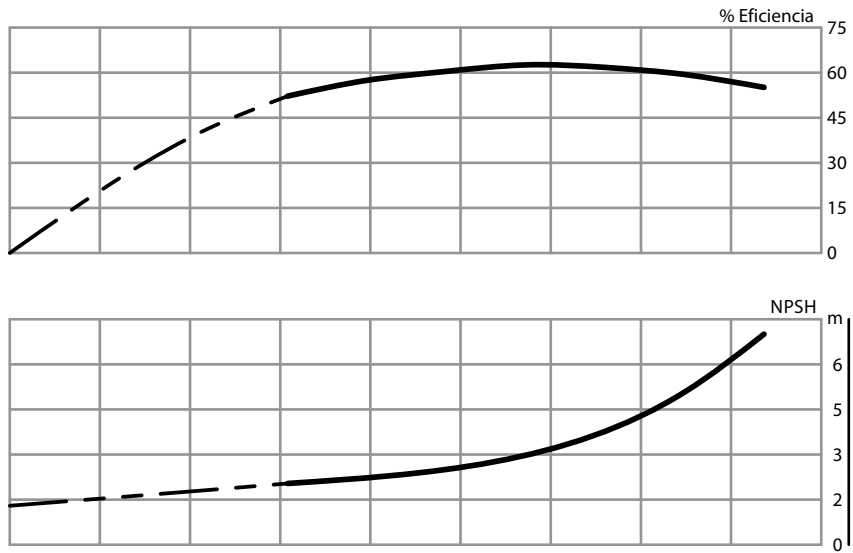
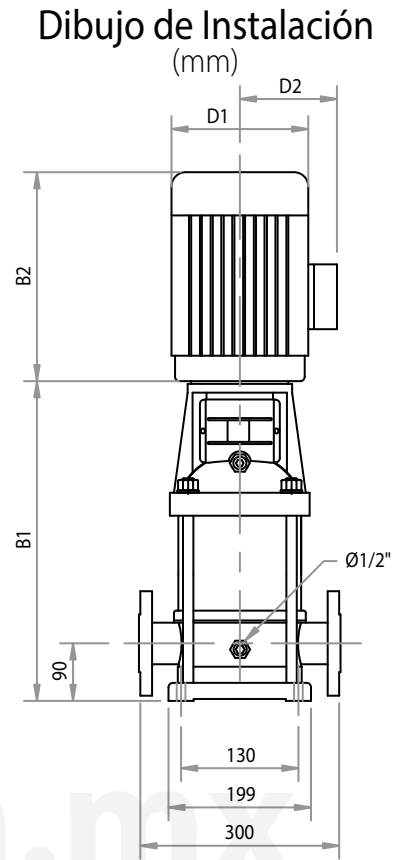
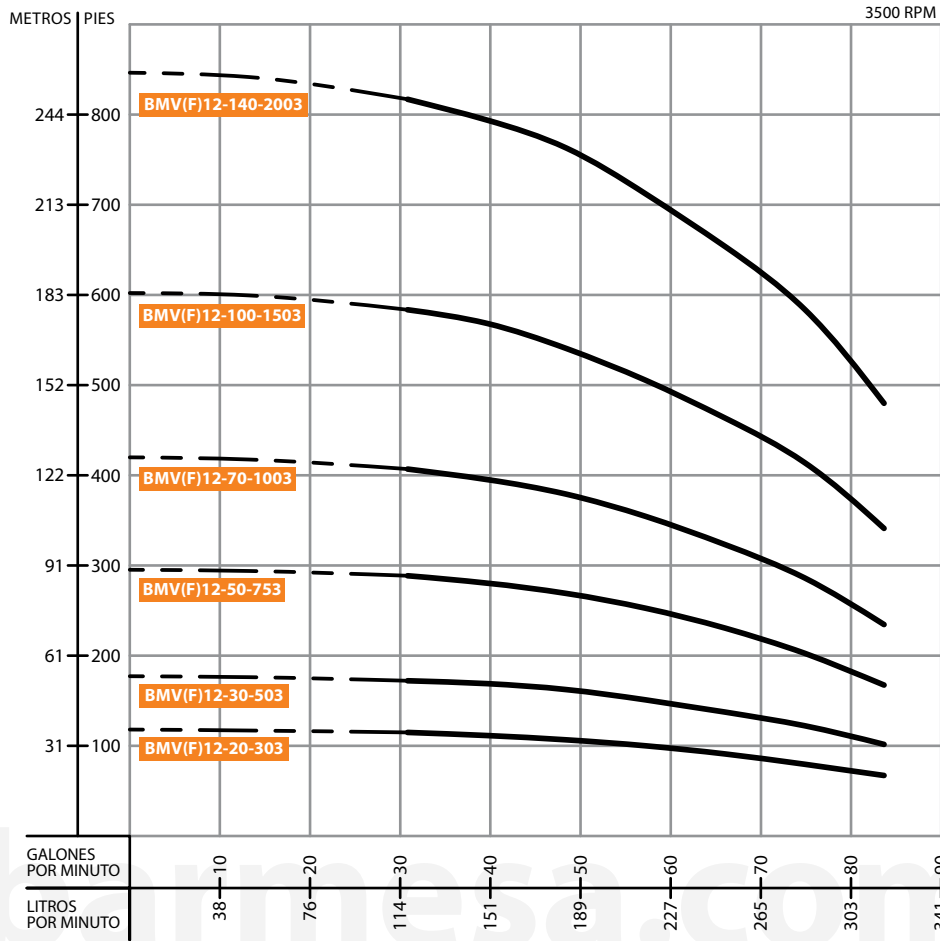
Curva de rendimiento BMVF15

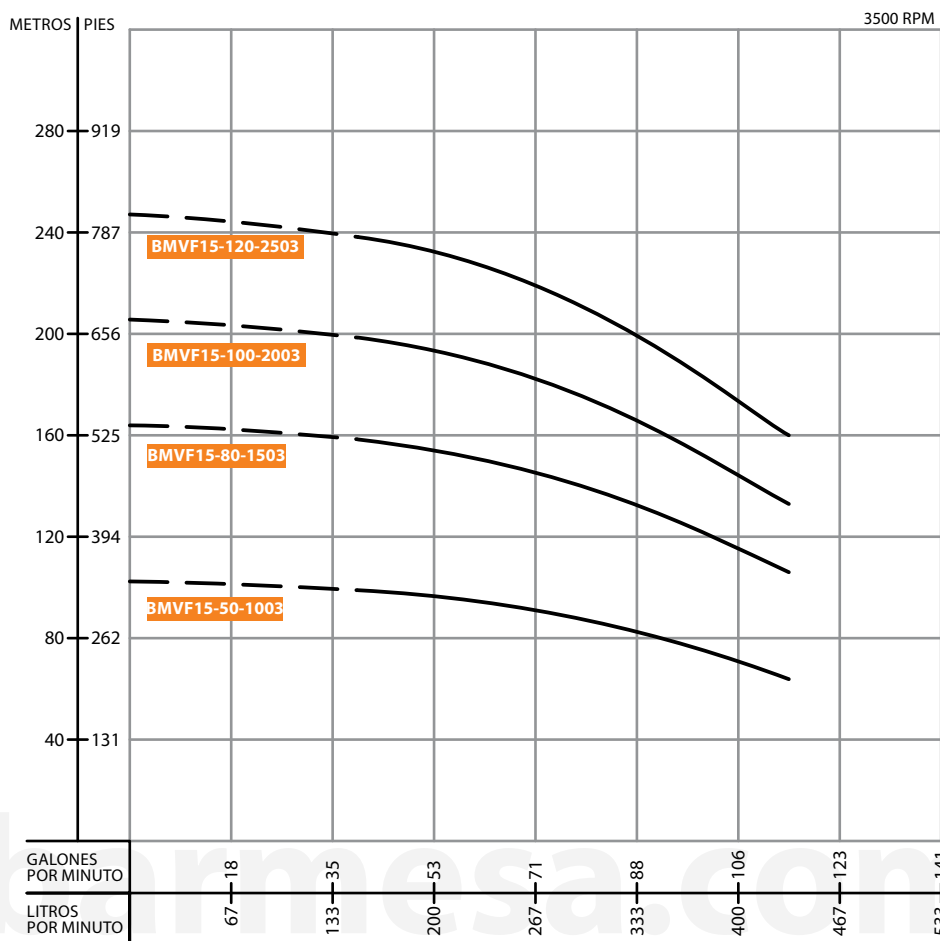

Dibujo de Instalación (mm)



Tabla de Rendimiento

MODELO	PASOS	HP	Q (LPM)	150	183.3	216.6	250	283.3	316.6	350	400	433.3
BMVF15-50-1003	5	10	H (m)	99	96	95	92.5	89.5	84.5	80	71	64
BMVF15-80-1503	8	15		158.5	155.5	152.5	149	144.5	137	130	115.5	106
BMVF15-100-2003	10	20		198.5	194.5	191	186.5	180.5	172	162.5	145	133
BMVF15-120-2503	12	25		238	234	229.5	224	217	207.5	196	175	160

Dimensiones y Pesos

B1	B2	B1+B2	TAMAÑO (mm)		PESO (kg)
			D1	D2	
607	400	1007	260	210	82
830	510	1340	330	255	156
920	510	1430	330	255	171
1010	560	1570	330	255	192

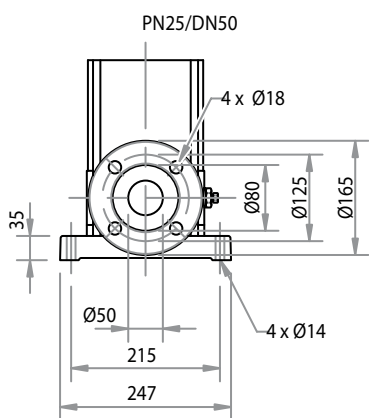
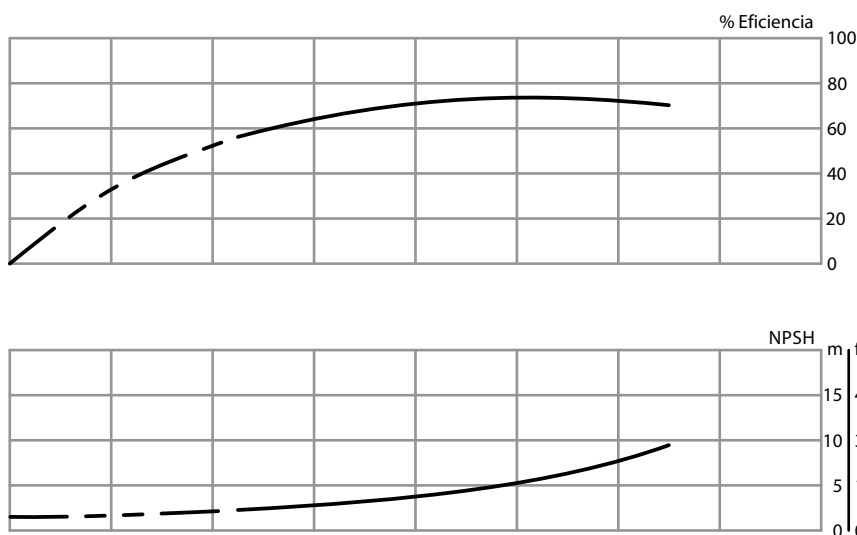
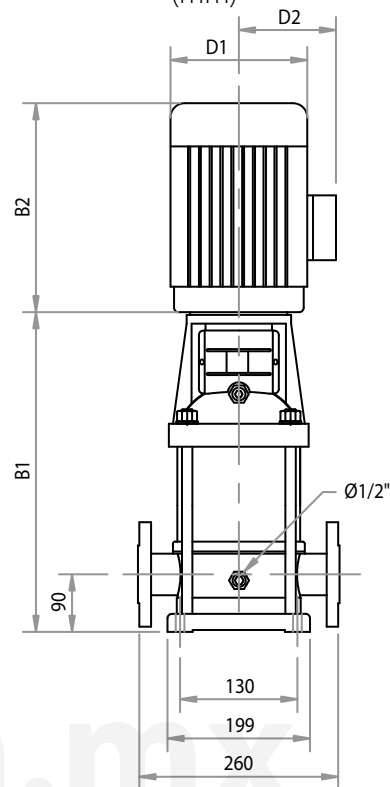
Curva de rendimiento BMV(F)16

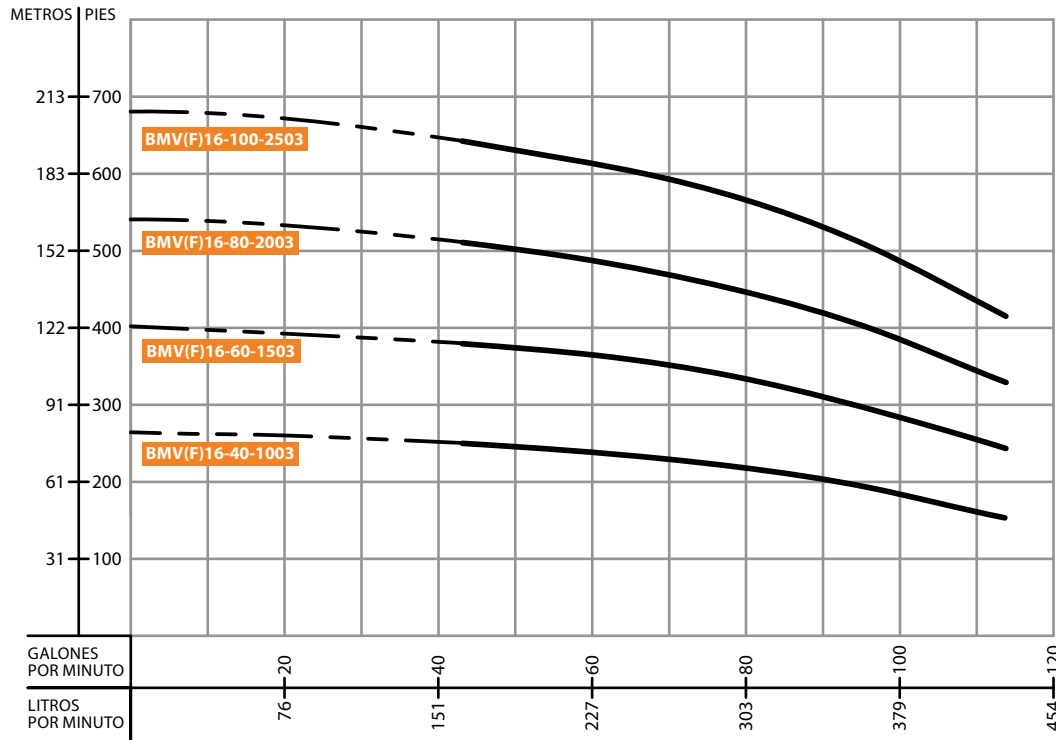

Dibujo de Instalación (mm)



Tabla de Rendimiento

MODELO	PASOS	HP	Q (LPM)	166.7	200	233.3	266.7	300	333.3	366.7	400	433.3
BMV(F)16-40-1003	4	10	H (m)	76	75	73	72	68	64	60	54	49
BMV(F)16-60-1503	6	15		115	113	111	108	102	96	91	82	75
BMV(F)16-80-2003	8	20		155	152	148	144	137	130	122	111	101
BMV(F)16-100-2503	10	25		197	192	187	181	174	165	153	139	127

Dimensiones y Pesos

TAMAÑO (mm)	TAMAÑO (mm)					PESO (kg)
	B1	B2	B1+B2	D1	D2	
4	517	430	947	260	208	75
6	695	490	1185	330	255	150
8	785	490	1275	330	255	163
10	875	550	1425	330	255	186

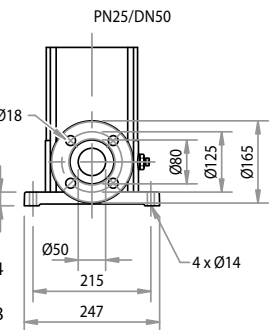
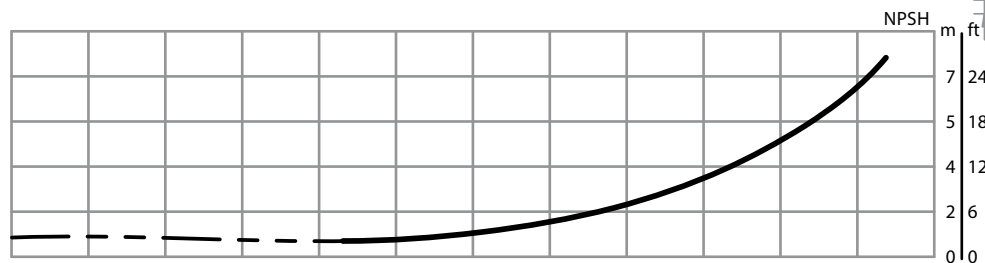
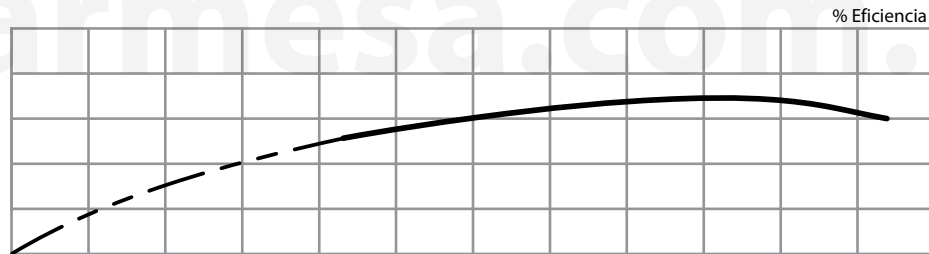
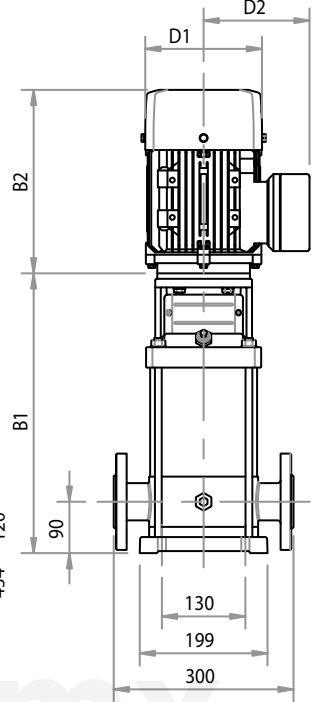
Curva de rendimiento BMV(F)20

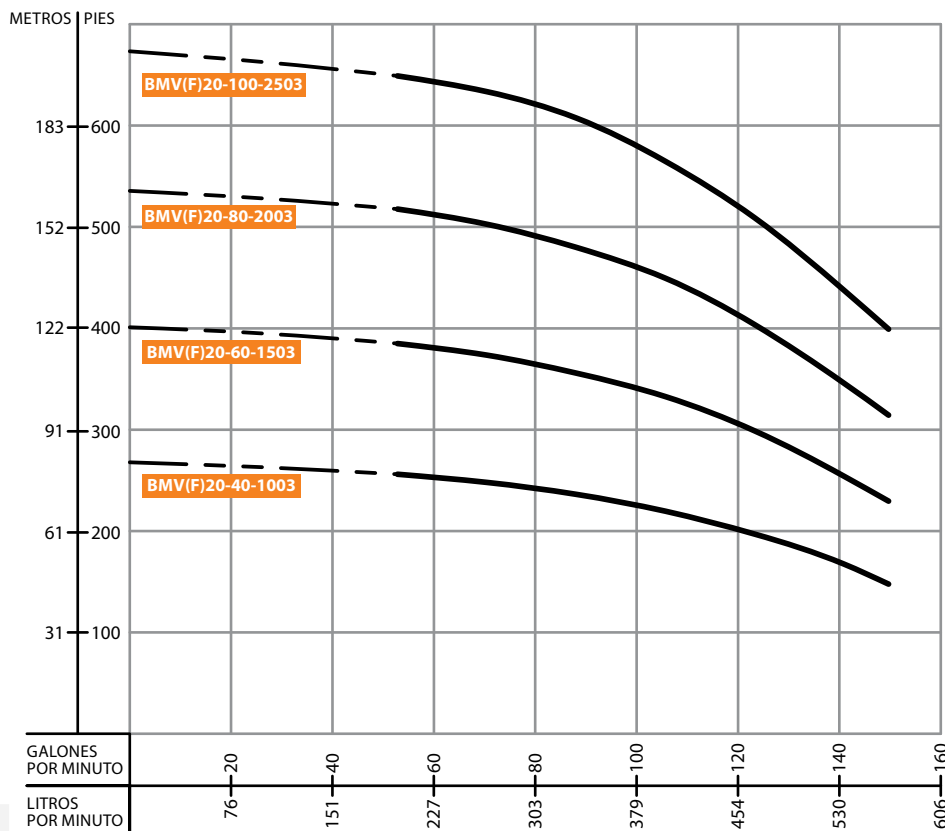

Dibujo de Instalación (mm)



Tabla de Rendimiento

MODELO	PASOS	HP	Q (LPM)	200	266.7	333.3	400	466.7	533.3	566.7
BMV(F)20-40-1003	4	10	H (m)	78	75	72	67	60	51	45
BMV(F)20-60-1503	6	15		118	113	108	102	91	77	70
BMV(F)20-80-2003	8	20		158	153	146	137	123	105	96
BMV(F)20-100-2503	10	25		198	193	185	172	155	133	122

Dimensiones y Pesos

TAMAÑO (mm)					PESO (kg)
B1	B2	B1+B2	D1	D2	
517	430	947	260	208	79
695	490	1185	330	255	150
785	490	1275	330	255	163
875	550	1425	330	255	187

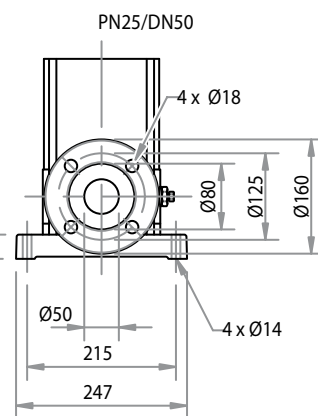
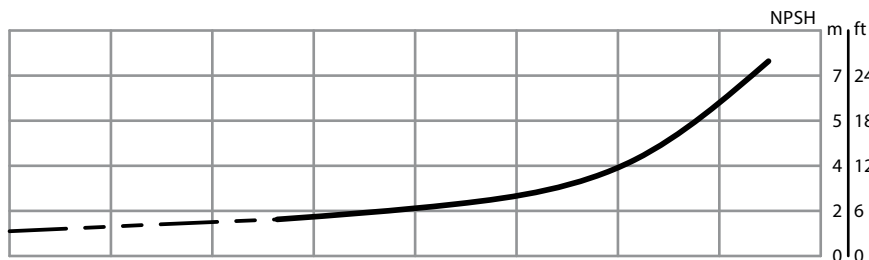
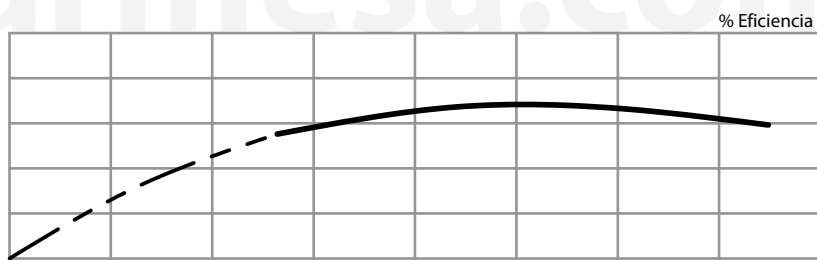
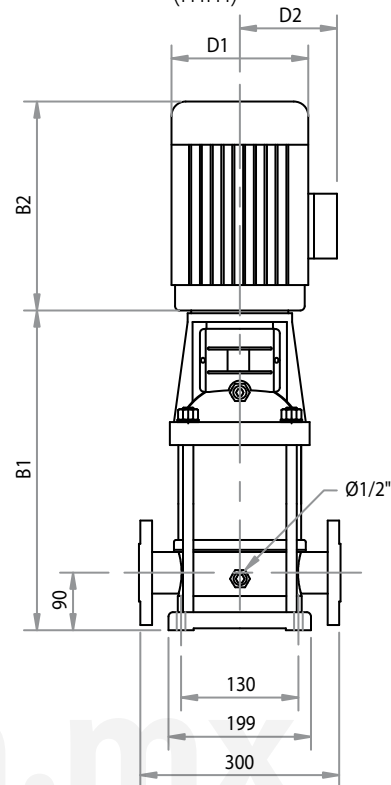
Curva de rendimiento BMV(F)32

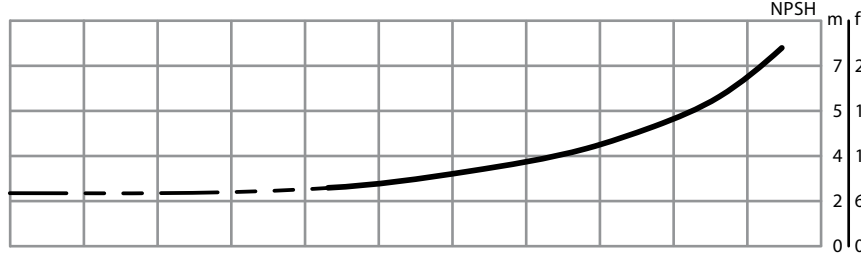
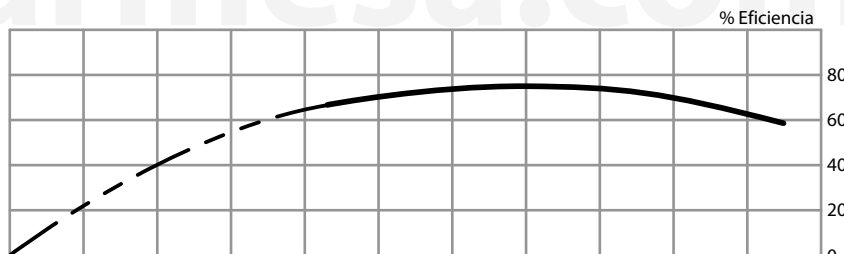
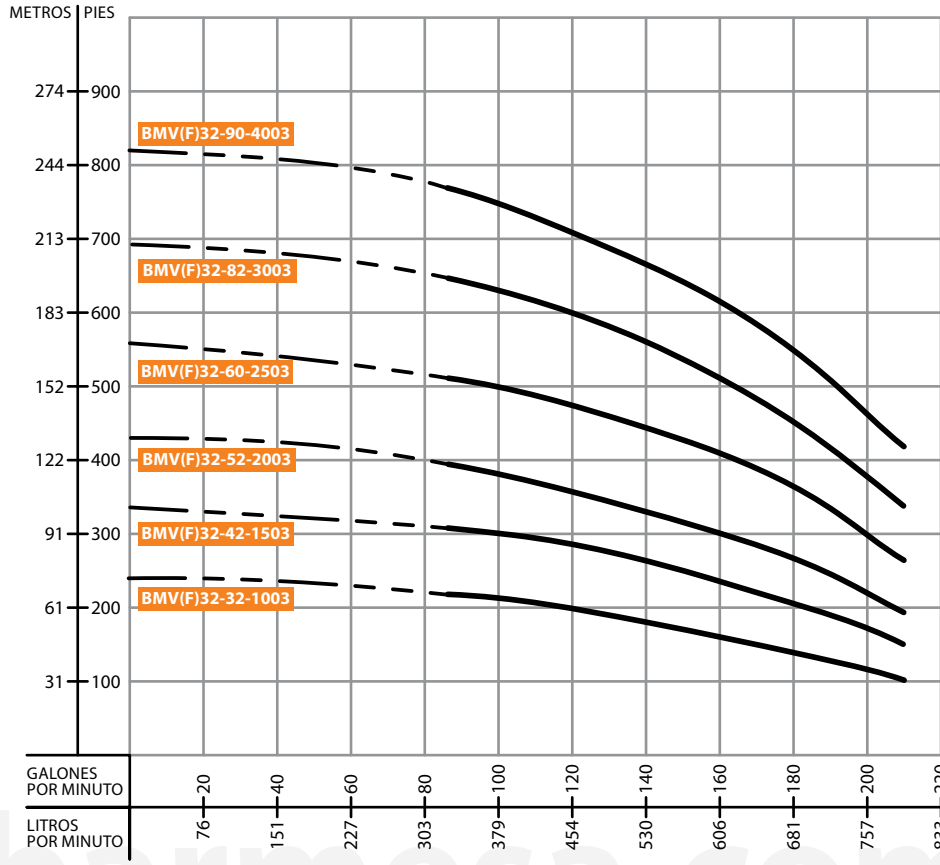

Dibujo de Instalación (mm)



Tabla de Rendimiento

MODELO	PASOS	HP	Q (LPM)	333.3	400	466.7	533.3	600	666.7	733.3	800
BMV(F)32-32-1003	3	10	H (m)	67	64	61	57	52	46	39	31
BMV(F)32-42-1503	4	15		94	91	87	81	73	65	56	45
BMV(F)32-52-2003	5	20		119	115	109	102	94	84	73	59
BMV(F)32-60-2503	6	25		155	150	144	136	126	114	100	81
BMV(F)32-82-3003	8	30		196	190	182	172	159	143	124	102
BMV(F)32-90-4003	9	40		234	226	216	204	189	172	152	127

Dimensiones y Pesos

TAMAÑO (mm)	TAMAÑO (mm)				PESO (kg)	
	B1	B2	B1+B2	D1		D2
32	645	490	1135	330	255	104
42	820	490	1310	330	255	176
52	890	490	1380	330	255	191
60	960	550	1510	330	255	216
82	1100	590	1690	400	310	259
90	1170	660	1830	400	310	319

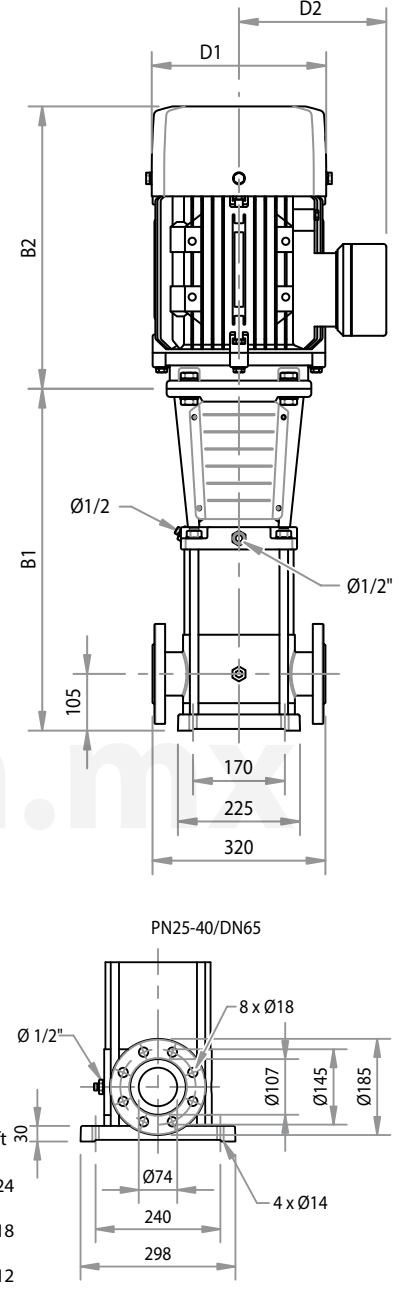
Curva de rendimiento BMV(F)42

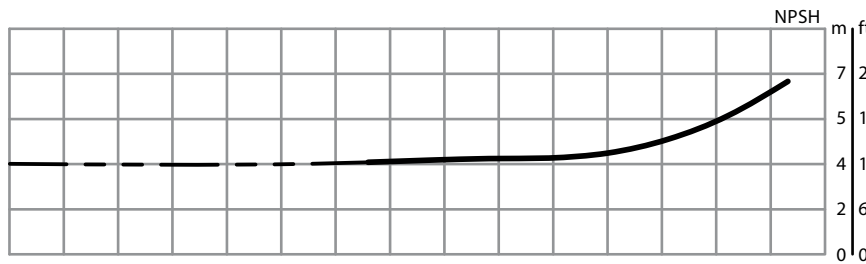
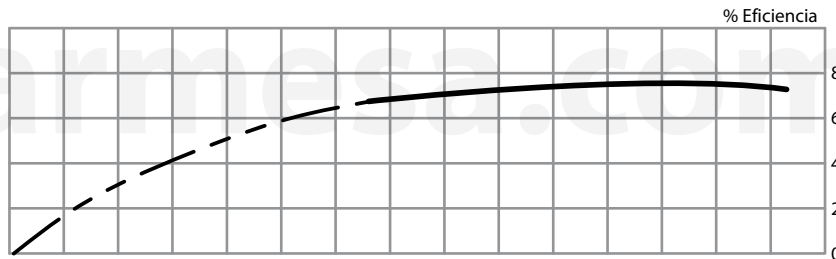
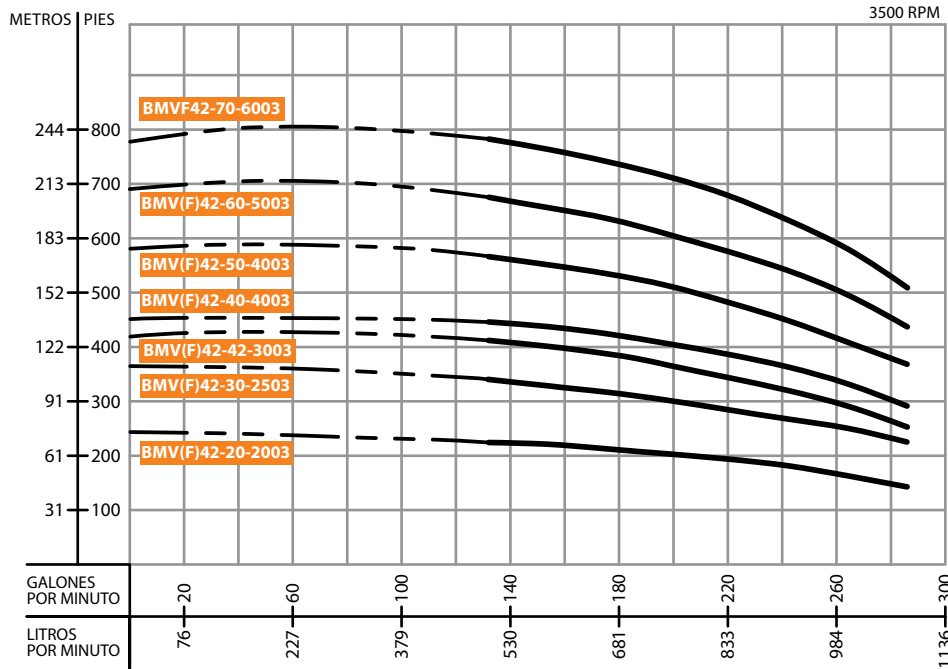

Dibujo de Instalación (mm)



Tabla de Rendimiento

MODELO	PASOS	HP	Q (LPM)	500	583.3	666.7	750	833.3	916.7	1000	1083.3
BMV(F)42-20-2003	2	20	H (m)	69	67	65	61	59	55	50	44
BMV(F)42-30-2503	3	25		102	100	97	92	88	82	76	68
BMV(F)42-42-3003	4	30		125	121	118	112	105	98	89	78
BMV(F)42-40-4003	4	40		136	133	129	123	117	112	102	89
BMV(F)42-50-4003	5	40		171	166	161	154	145	138	126	112
BMV(F)42-60-5003	6	50		205	200	193	186	176	166	152	134
BMVF42-70-6003	7	60		239	232	226	216	204	194	178	157

Dimensiones y Pesos

B1	TAMAÑO (mm)					PESO (kg)
	B2	B1+B2	D1	D2		
748	490	1238	330	255	188	
828	550	1378	330	255	213	
908	590	1498	360	285	253	
908	660	1568	400	310	309	
988	660	1648	400	310	313	
1068	660	1728	400	310	340	
1148	700	1848	460	340	404	

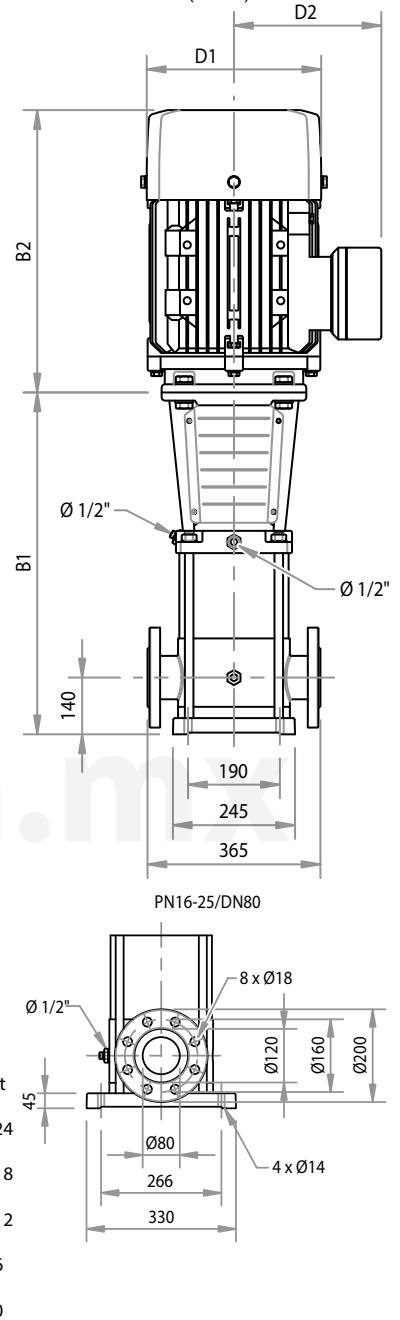
Curva de rendimiento BMV(F)65

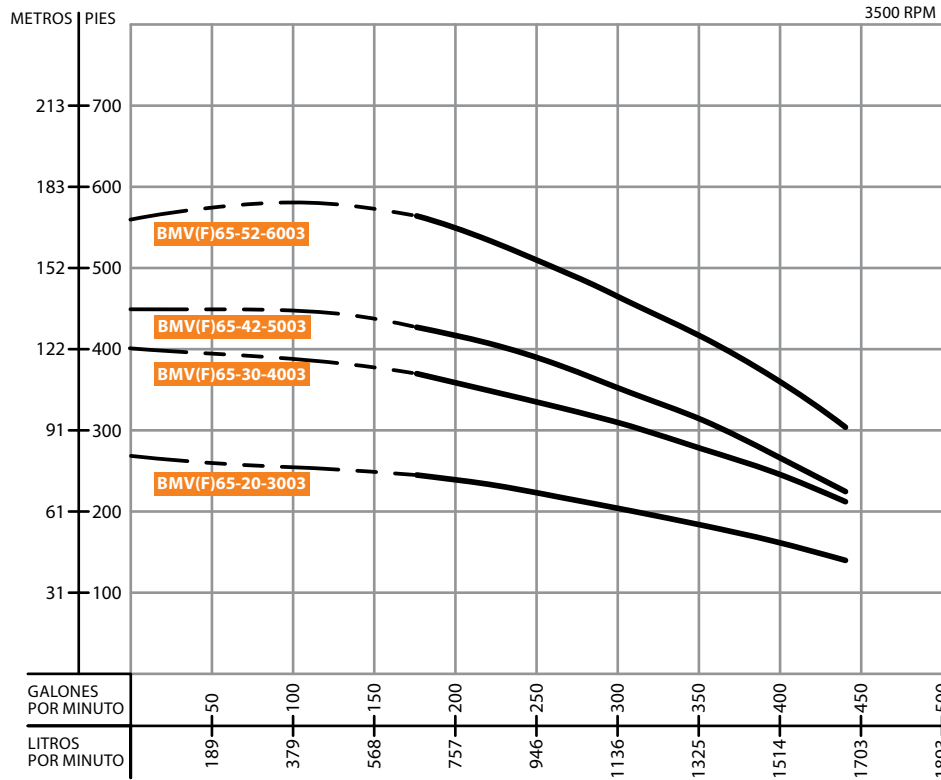

Dibujo de Instalación (mm)



Tabla de Rendimiento

MODELO	PASOS	HP	Q (LPM)	666.7	833.3	1000	1083.3	1166.7	1333.3	1500	1666.7
BMV(F)65-20-3003	2	30	H (m)	74	72	67	64	62	57	51	42
BMV(F)65-30-4003	3	40		112	108	100	96	93	86	77	65
BMV(F)65-42-5003	4	50		130	124	115	110	103	94	83	66
BMV(F)65-52-6003	5	60		172	162	151	144	137	126	112	91

Dimensiones y Pesos

TAMAÑO (mm)					PESO (kg)
B1	B2	B1+B2	D1	D2	
754	590	1344	360	285	248
836	660	1496	400	310	313
919	660	1579	400	310	336
1001	700	1701	460	340	402

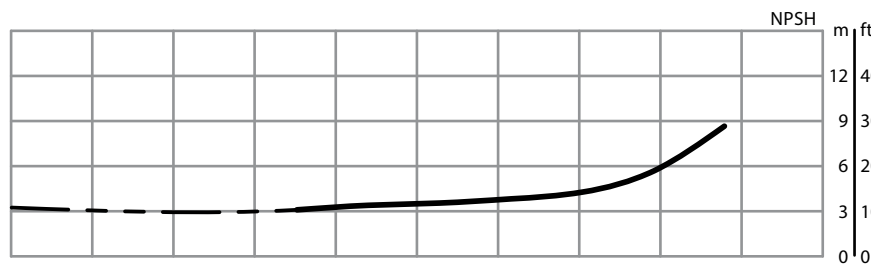
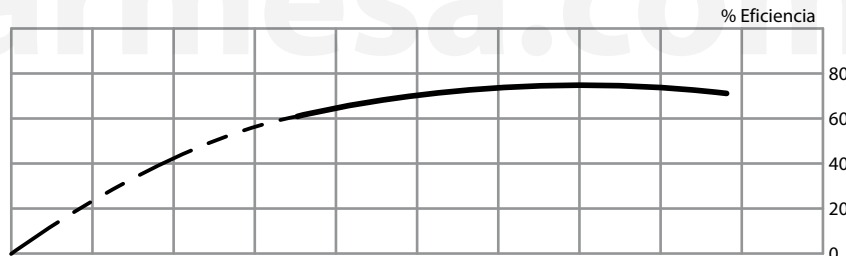
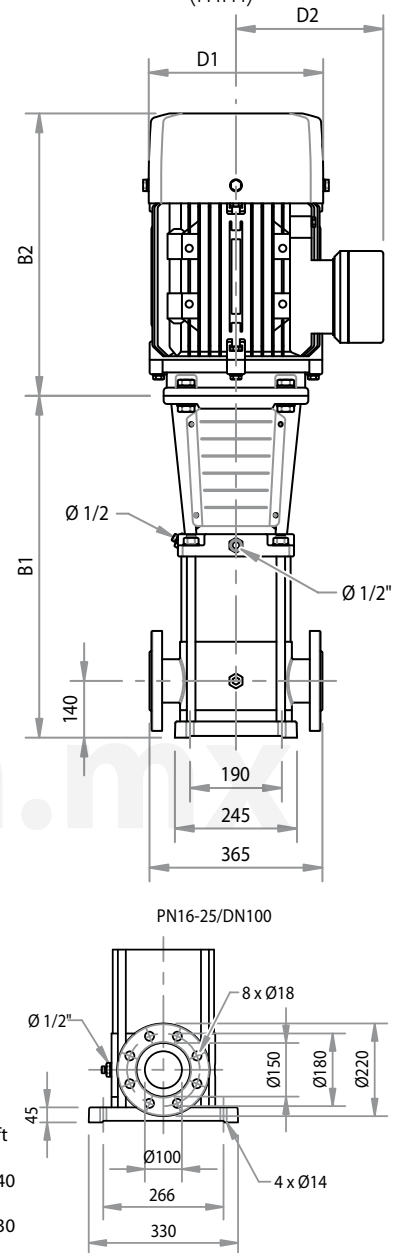
Curva de rendimiento BMVF90

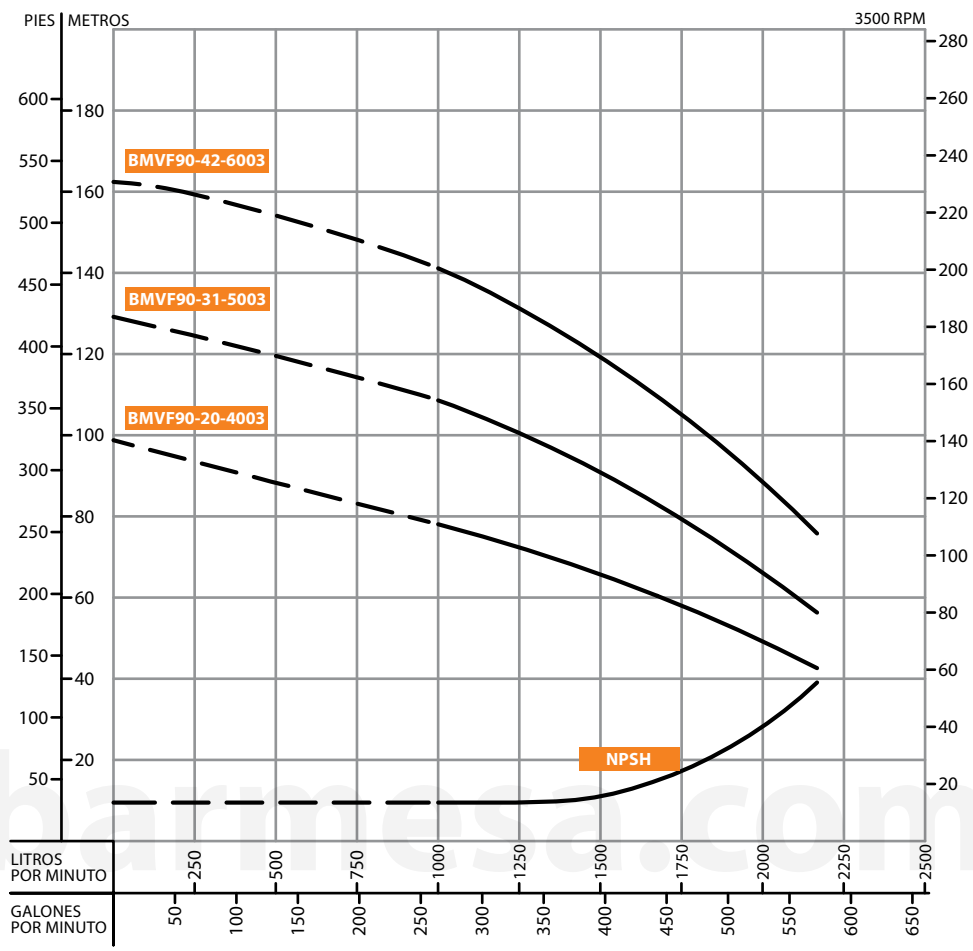

Dibujo de Instalación (mm)



Tabla de Rendimiento

MODELO	PASOS	HP	Q (LPM)	1000	1166.6	1333.3	1500	1666.6	1833.3	2000	2166.6
BMVF90-20-4003	2	40	H (m)	76	73	69	64	60	56	52	44
BMVF90-31-5003	3	50		108	104	98	90	83	78	69	56
BMVF90-42-6003	4	60		141	135	128	118	109	102	89	72

Dimensiones y Pesos

TAMAÑO (mm)					PESO (kg)
B1	B2	B1+B2	D1	D2	
773	660	1433	400	310	304
865	660	1525	400	310	330
957	700	1657	460	340	396

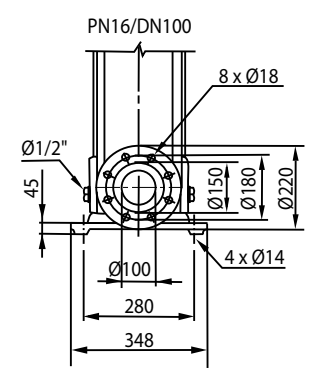
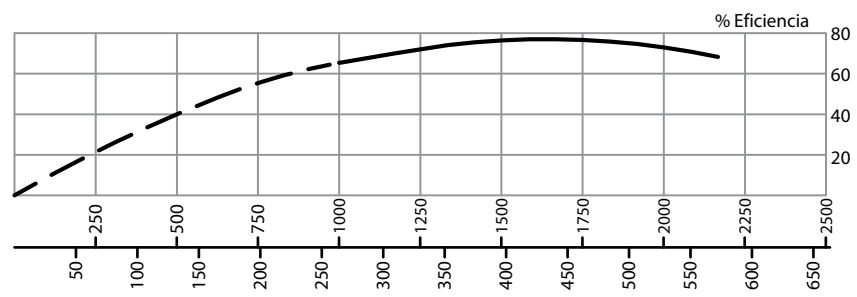
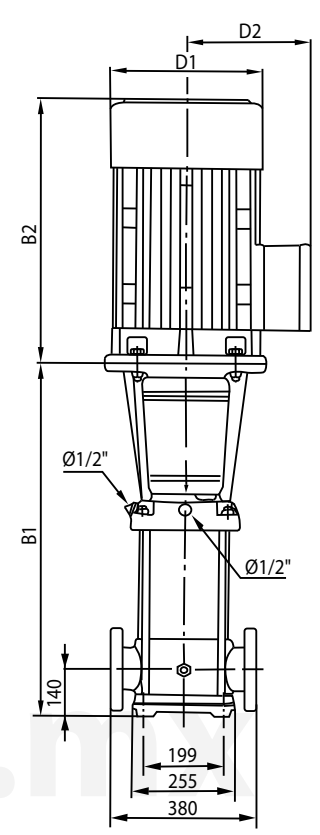
Curva de rendimiento BMVF120

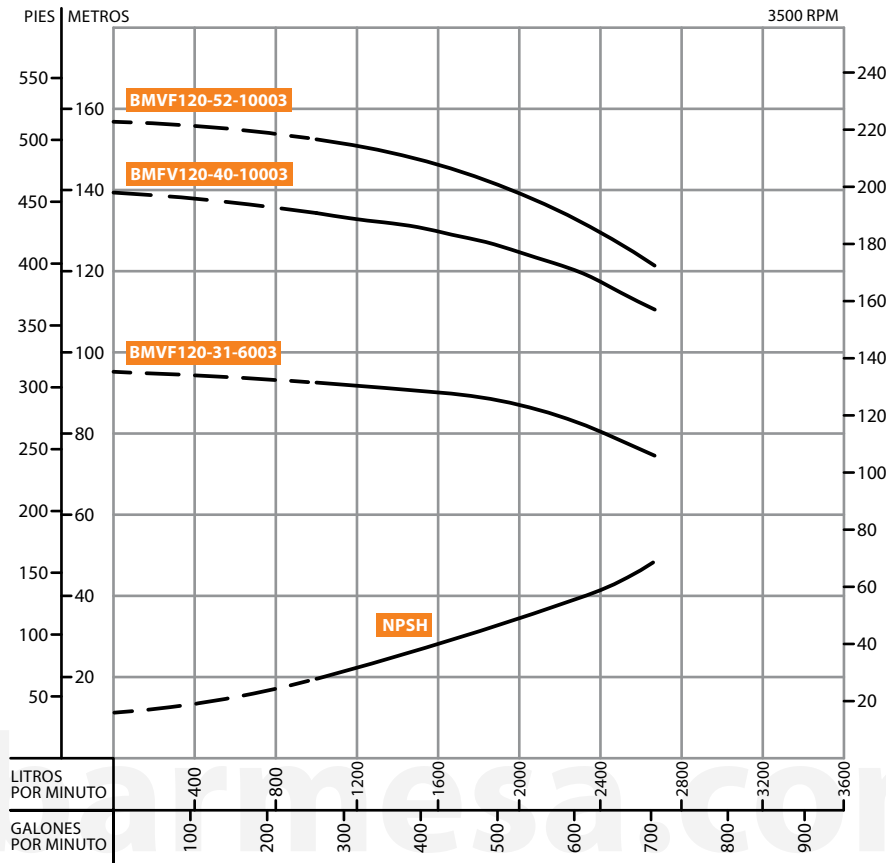

Dibujo de Instalación (mm)



Tabla de Rendimiento

MODELO	PASOS	HP	Q (LPM)	1000	1166.6	1333.3	1500	1666.6	1833.3	2000	2166.6	2333.3	2500	2666.6
BMVF120-31-6003	3	60	H (m)	91.3	91	90.4	89	87.7	86	84.4	82	80	76.7	73.3
BMVF120-40-10003	4	100		134	133	132	131	129.5	127.5	125	122	119	114.5	109.5
BMVF120-52-10003	5	100		152	151	149.7	147	144	141.5	139	135.5	132	127	122

Dimensiones y Pesos

TAMAÑO (mm)					PESO (kg)
B1	B2	B1+B2	D1	D2	
1160	700	1860	460	340	445
1350	845	2195	580	410	675
1510	845	2355	580	410	690

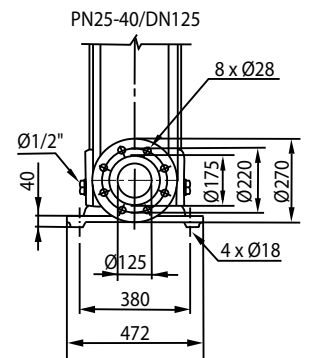
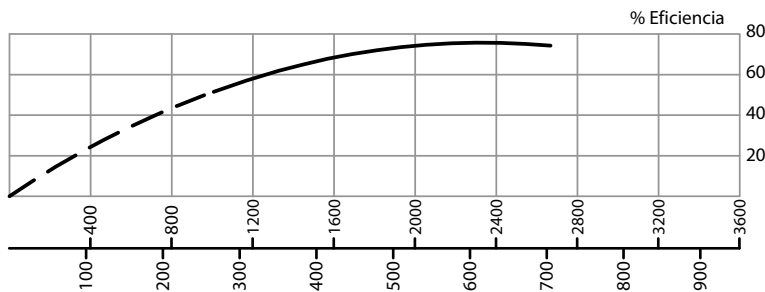
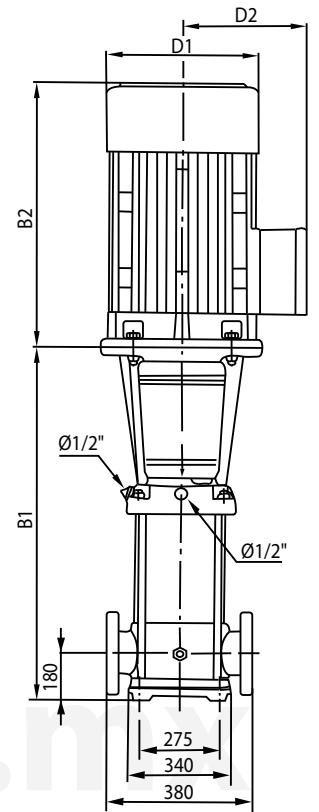
Curva de rendimiento BMVF150

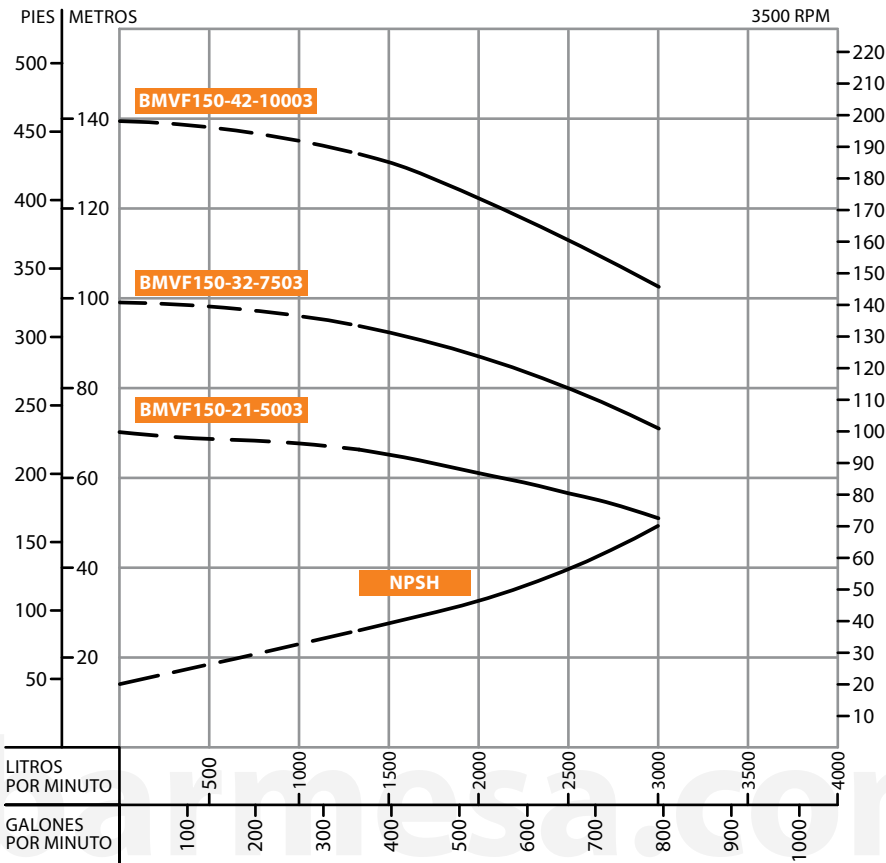

Dibujo de Instalación (mm)



Tabla de Rendimiento

MODELO	PASOS	HP	Q (LPM)	1333.3	1500	1666.6	1833.3	2000	2166.6	2333.3	2500	2666.6	2833.3	3000
BMVF150-21-5003	2	50	H (m)	67	65	63.5	62	61	60	58.5	56	55	53	51
BMVF150-32-7503	3	75		94	92	90.5	88.4	86.4	83.8	81	80	78	75.3	72.5
BMVF150-42-10003	4	100		133	130.3	127.6	124.6	121.7	118.3	115	112.5	110	106.3	102.5

Dimensiones y Pesos

B1	TAMAÑO (mm)					PESO (kg)
	B2	B1+B2	D1	D2		
1000	660	1660	400	310	380	
1190	770	1960	510	370	545	
1350	845	2195	580	410	680	

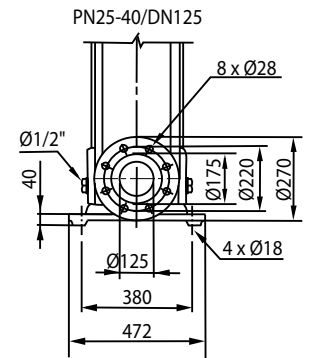
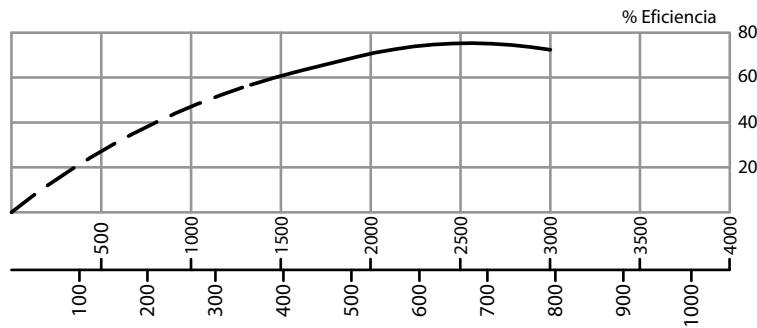
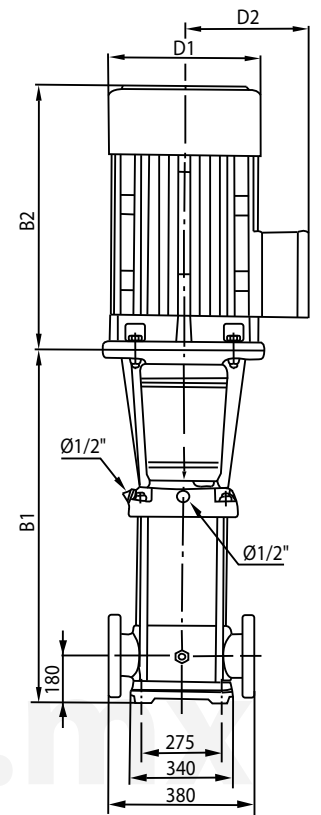
Curva de rendimiento BMVF200

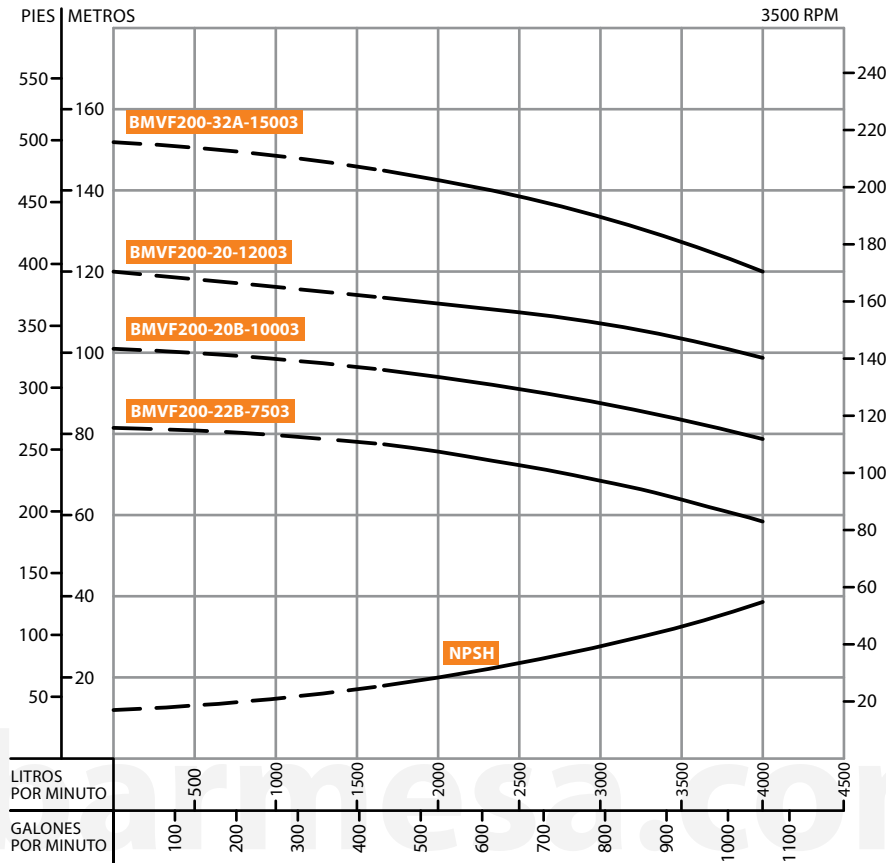

Dibujo de Instalación (mm)



Tabla de Rendimiento

MODELO	PASOS	HP	Q (LPM)	1666.6	2000	2333.3	2666.6	3000	3333.3	3666.6	4000
BMVF200-22B-7503	2	75	H (m)	77.5	75.5	73.5	71	68.5	66	62	58.5
BMVF200-20B-10003	2	100		95.5	93.5	92.5	90.5	88.5	86	82.5	79
BMVF200-20-12003	2	120		114	112.5	111	109.5	107.5	105	101.5	98.5
BMVF200-32A-15003	3	150		145	142.5	140	137	133.5	130	125.5	120

Dimensiones y Pesos

TAMAÑO (mm)	TAMAÑO (mm)		D1	D2	PESO (kg)
	B1	B2			
1131	770	1901	540	370	595
1131	845	1976	580	410	718
1131	895	2026	580	410	787
1325	1140	2465	645	550	1158

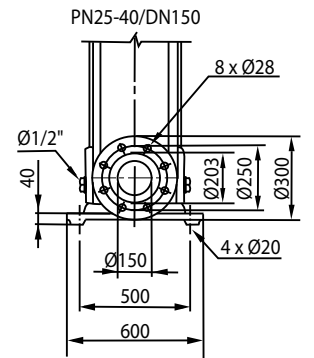
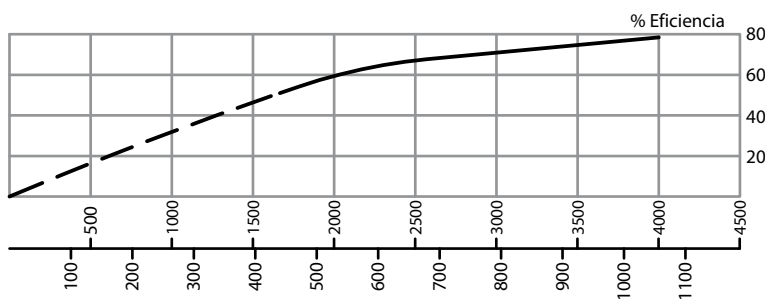
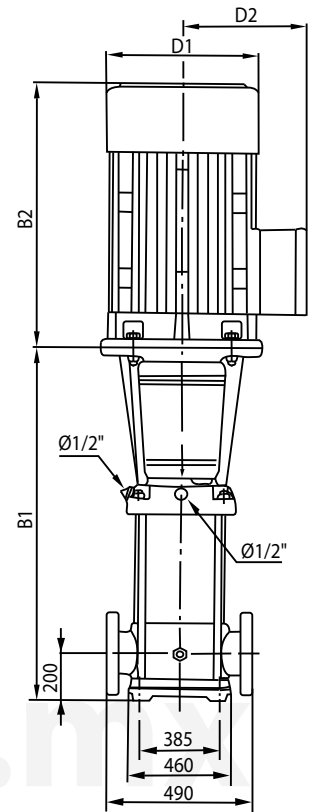
Monterrey, N.L. (Matriz)

D. Ladrón de Guevara 302 ote.
col. Del Norte C.P. 64500

☎ (81) 8863.3737 / 8351.3737

☎ (81) 8331.1777 / 8351.9609

✉ ventas@barnes.com.mx (bombas)
ventas@genmann.com (plantas)

Ciudad de México

Calle Poniente 122 #419 bodega 2
col. Barrio de Colongo, Azcapotzalco
entre calle Norte 35 y ave. Vallejo C.P. 02630

☎ (55) 3004.9530 y 31

(55) 5029.6970 y 71

✉ ofmexico@barnes.com.mx (bombas)
ofmexico@genmann.com (plantas)

Puebla, Puebla

Av. 15 Poniente #507 col. El Carmen
entre calles 5 y 7 Sur C.P. 72100

☎ (22) 2774.8264

☎ (22) 2774.8265

✉ ofpuebla@barnes.com.mx

Zapopan, Jalisco

Ramón Corona #295 col. Agua Blanca Industrial
entre calle Hidalgo y cerrada C.P. 45235

☎ (33) 3875.1150 y 51

☎ (33) 1199.1006 y 07

✉ ofgdl@barnes.com.mx (bombas)
ofgdl@genmann.com (plantas)

Mérida, Yucatán

Calle 10 #206-A x 35 y 37
col. San Juan Grande C.P. 97145

☎ (99) 9253.2240 y 41

☎ (99) 9124.8272 y 73

✉ ofmerida@barnes.com.mx

Barmesa S.A.S. - Colombia

Calle 23 #116-31 bodegas 19 y 20
Parque Industrial Puerto Central
Módulo 2 Bogotá D.C. Colombia.

☎ (1) 742.4453 / 742.4944 /

✉ ventas@barmesa.com

Barmesa Pumps LLC - USA

103 Flecha Lane
Laredo, TX 78045 USA.

☎ 844.BARMESA (2276372)

302 Meadowlark Drive
Mansfield, Ohio 44903 USA.

☎ +1 (419) 566.3318

✉ contact@barmesapumps.com

www.barmesa.com.mx

www.genmann.com

www.mannpumps.com

www.barmesa.com.co

www.barmesapumps.com