

DRILLING PROTOCOL FOR ROOTT IMPLANTS

CAVITY PREPARATION

Every person has a unique bone structure and the clinician has to adapt the drilling protocol to the individual bone quality and anatomical situation. Our drilling protocol is an optimal scheme for different types of bones: D1, D2-D3, D4.

**IMPORTANT!
WHEN PREPARING THE CAVITY FOR
THE IMPLANT, ALWAYS ENSURE COOLING.
USE ONLY SHARP INSTRUMENTS.**

DRILLING SPEED

Recommended drilling speed:

- initial drilling – 1200–1500 Rpm;
- pilot drilling – 900–1200 Rpm;
- form drilling – 200–800 Rpm.

Implantologist is responsible of drilling speed choice, taking into consideration his experience, preferences and special necessities of the patient.

Important notice: this protocol was prepared with a max speed of 700 rpm, with insertion torque for implants is from 35 to 50 Ncm.

IMPLANT POSITION

1. Crestal implant position.
2. Implant can be placed 1-2 mm deeper to help bone grow over implant - subcrestal implant position.

For the 2nd option drilling should go 1-2 mm deeper than implant length.

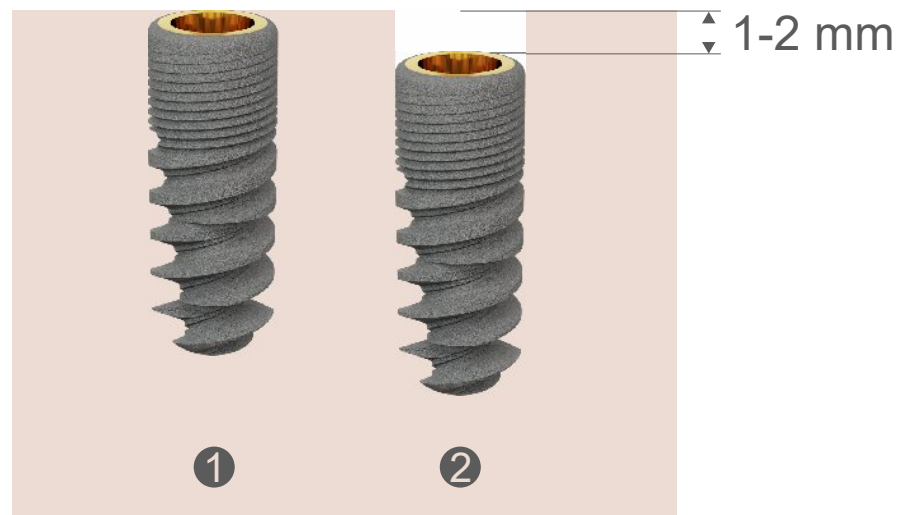

ROOTT^R implants installation using tapered drills

DRILLS

Lance drill DB2020 can be used for initial drilling by setting the drilling axis before using pilot drill D2020.

Drill with tapered drills to the appropriate depth, required for a specific case.

If after using the previous drill the torque is still more than 50 Ncm while inserting the implant, the cavity has to be widened. Just widen the osteotomy with drill D5506.

All drills have laser marking, which indicates drill's depth in the bone. Markings are lasered every 2 millimetres, pilot drill from 4 to 18 mm, tapered drills from 4 to 16 mm.

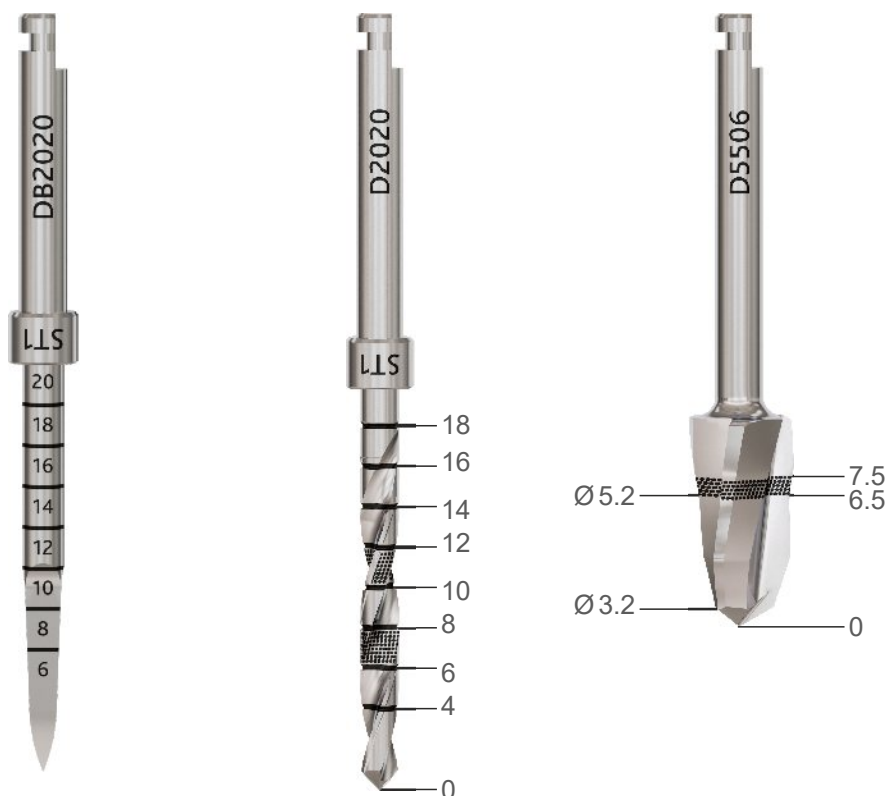

Tapered drills have V-shaped tips, for better correlation with the implant, 3 cutting edges offer good stability. The tapered shape reduces frictional heating. Variable helix for enhanced drilling control and twisted flute for bone extraction. Angled back cutting edge allows compressing of bone when drilling in counter-clock wise (reverse).



NOTE







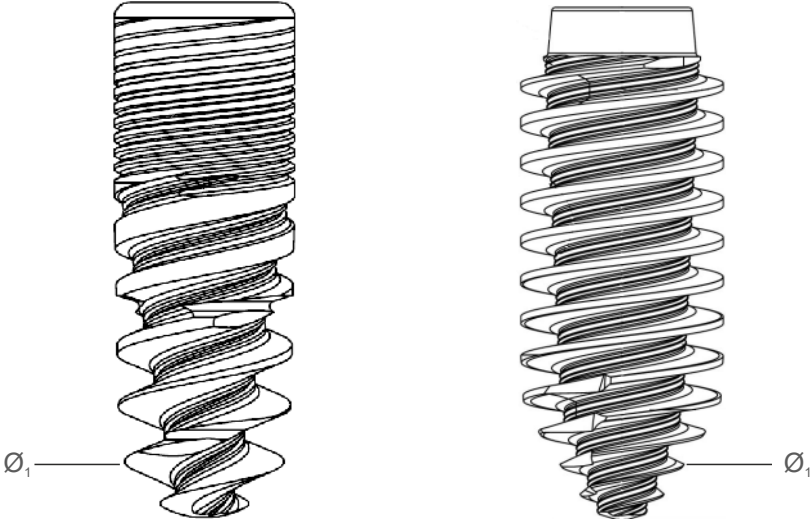



























For the best result it is recommended to use a smaller diameter drill and try inserting the implant.

IMPLANTS

ROOTT R implant sizes from R3010 to R4206 are “U” shape. Sizes from R4208 to R4816 are “V” shape and have different drilling protocols. Implants R5506 to R5516 have different shapes of threads and have different drilling protocols.



Diameter of the second thread, mm

	Ø 3.0	Ø 3.5	Ø 3.8	Ø 4.2	Ø 4.8	Ø 5.5
L 6 mm Ø ₁		R3506  3.4	R3806  3.7	R4206  4.1	R4806  4.1	R5506  3.9
L 8 mm Ø ₁		R3508  3.3	R3808  3.7	4208  3.5	R4808  4.1	R5508  3.9
L 10 mm Ø ₁	R3010  2.8	R3510  3.3	R3810  3.6	R4210  3.4	R4810  4.0	R5510  1.7
L 12 mm Ø ₁	R3012  2.7	R3512  3.3	R3812  3.6	R4212  3.4	R4812  4.0	R5512  1.7
L 14 mm Ø ₁	R3014  2.5	R3514  3.2	R3814  3.5	R4214  3.3	R4814  3.9	R5514  1.7
L 16 mm Ø ₁	R3016  2.4	R3516  3.1	R3816  3.4	R4216  3.2	R4816  3.8	R5516  1.7

IMPLANTS R30XX

D4 BONE

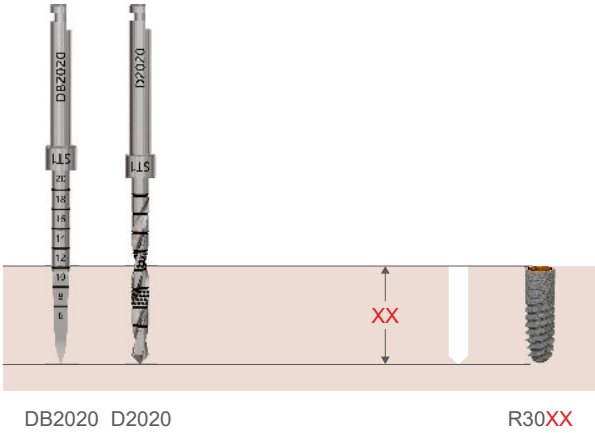

D2-D3 BONE

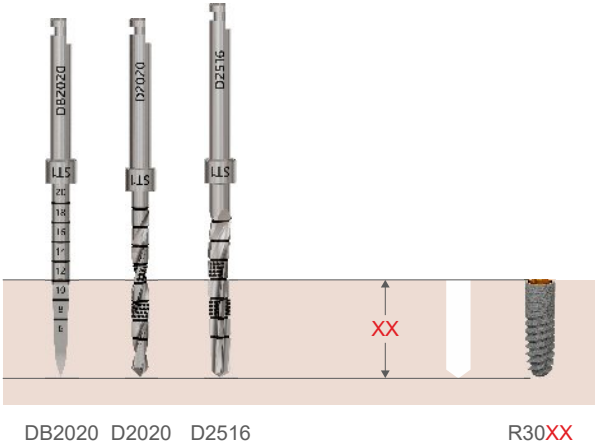

D1 BONE

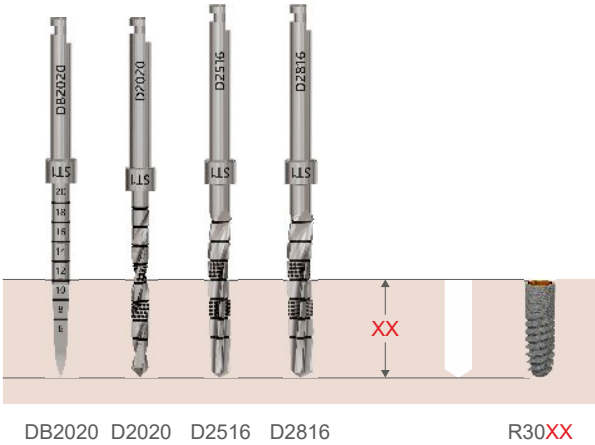

Here xx is the length of the implant, mm

IMPLANTS R35XX

D4 BONE

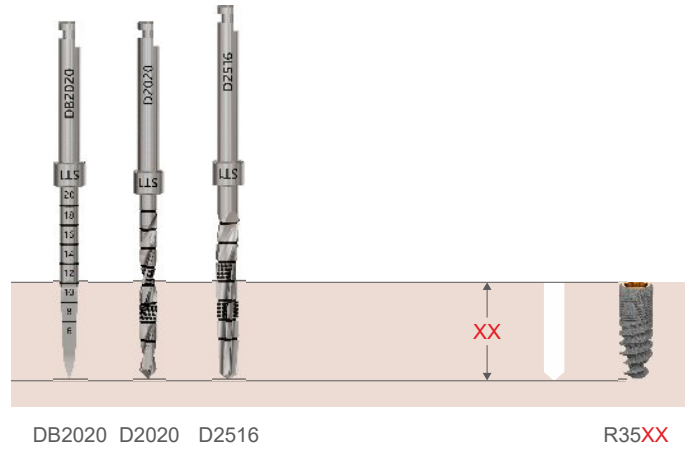

D2-D3 BONE

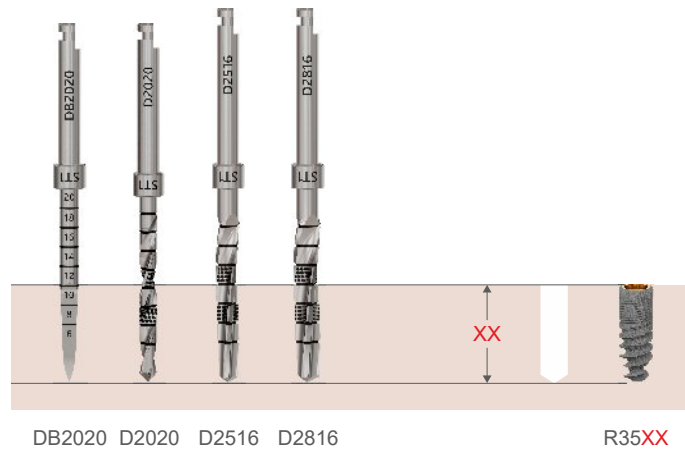

D1 BONE

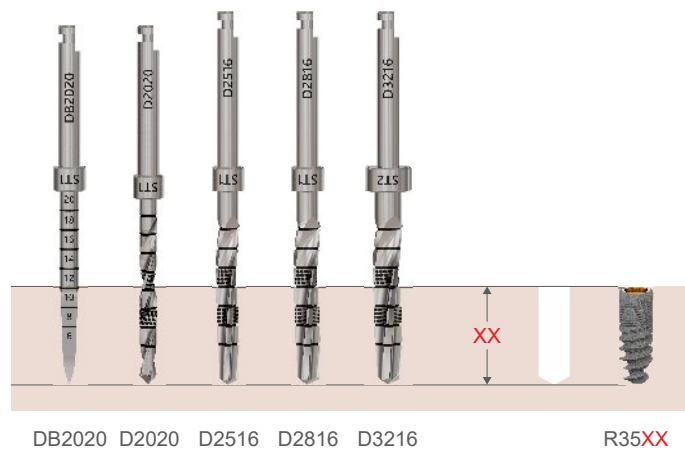

Here xx is the length of the implant, mm

IMPLANTS R38XX

D4 BONE

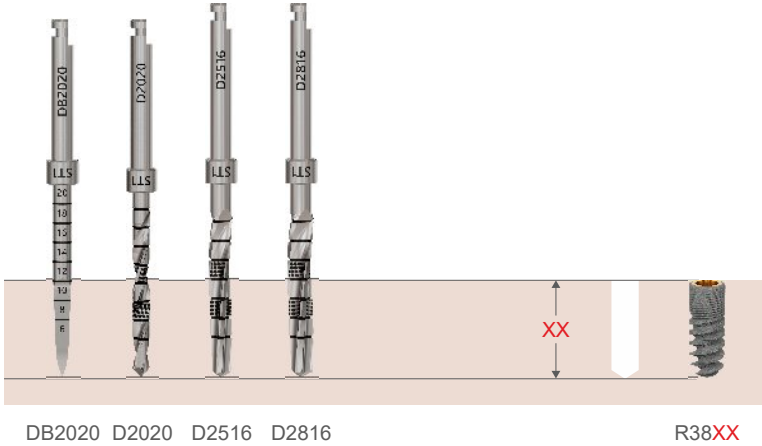

D2-D3 BONE

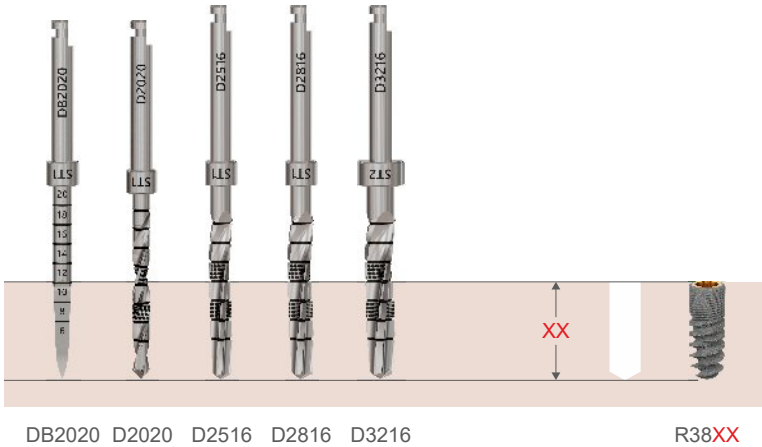

D1 BONE

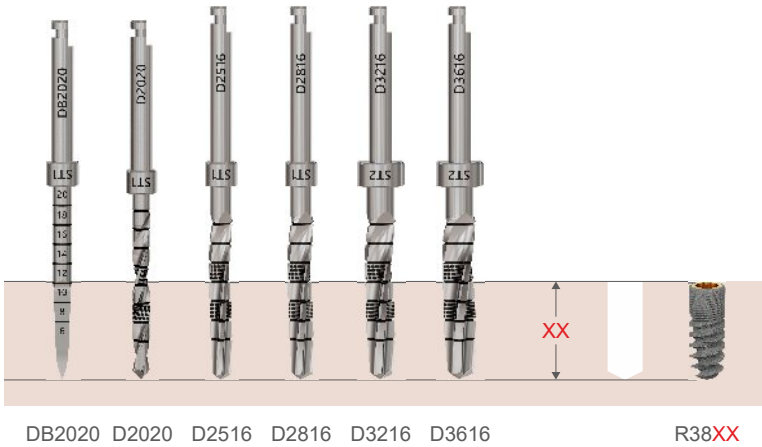

Here xx is the length of the implant, mm

IMPLANTS R42XX

D4 BONE

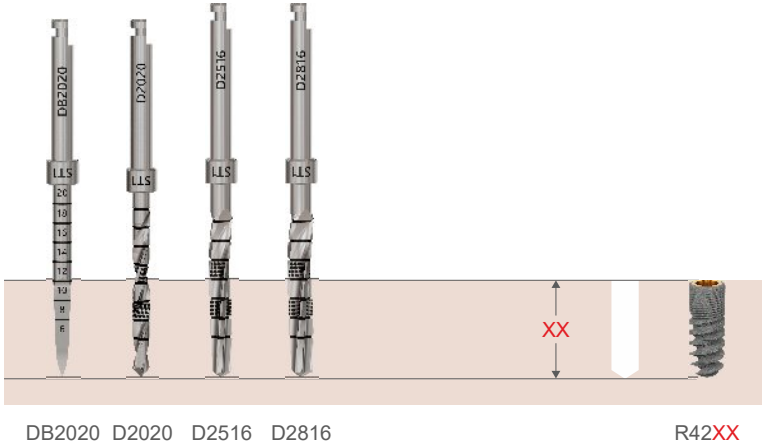

D2-D3 BONE

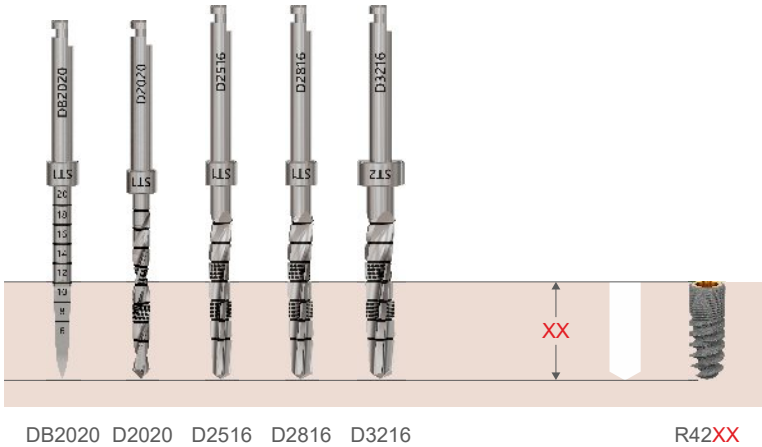

D1 BONE

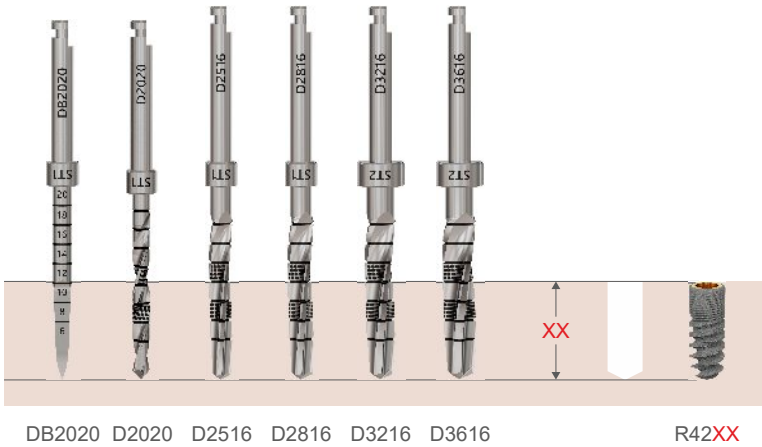

Here xx is the length of the implant, mm

IMPLANTS R4206

D4 BONE

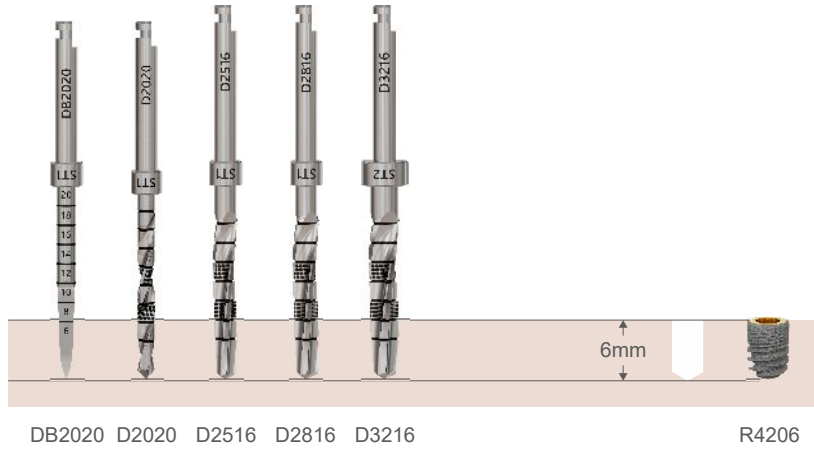

D2-D3 BONE

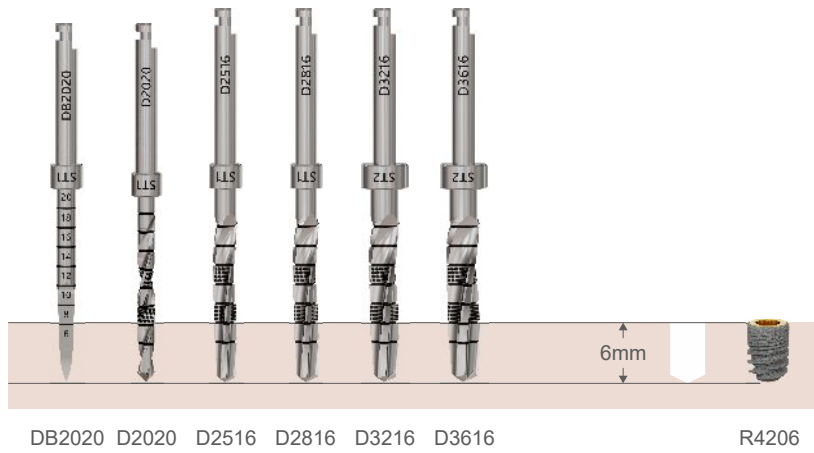

D1 BONE

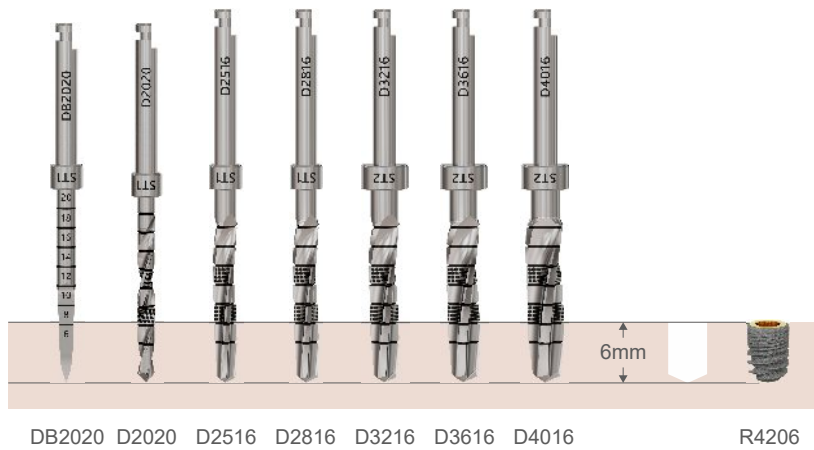

IMPLANTS R48XX

D4 BONE

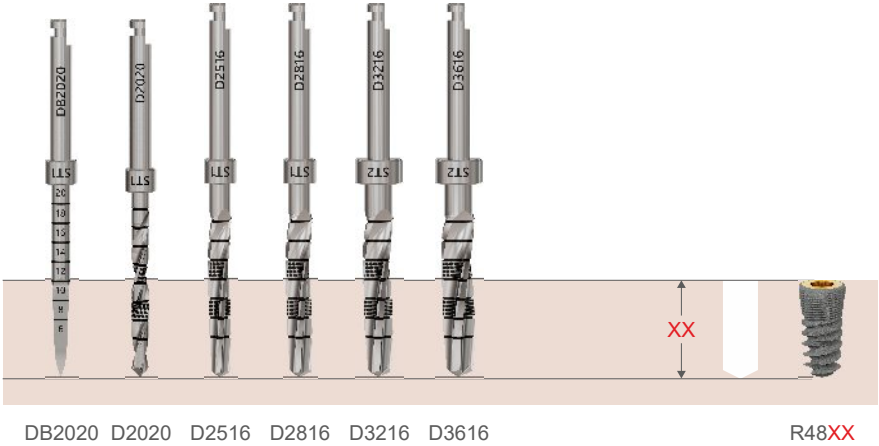

D2-D3 BONE

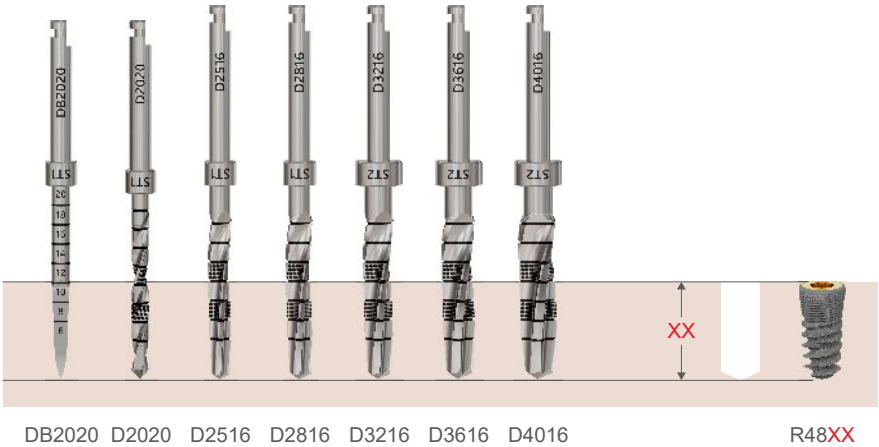

D1 BONE

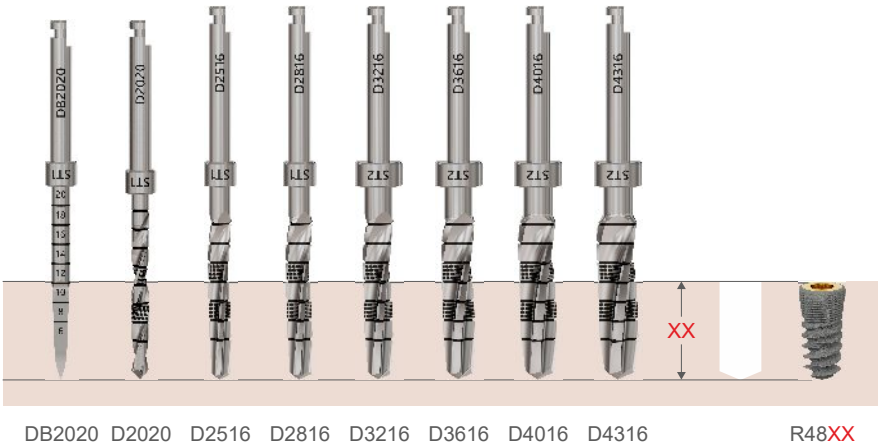

Here xx is the length of the implant, mm

IMPLANTS R55XX

D4 BONE

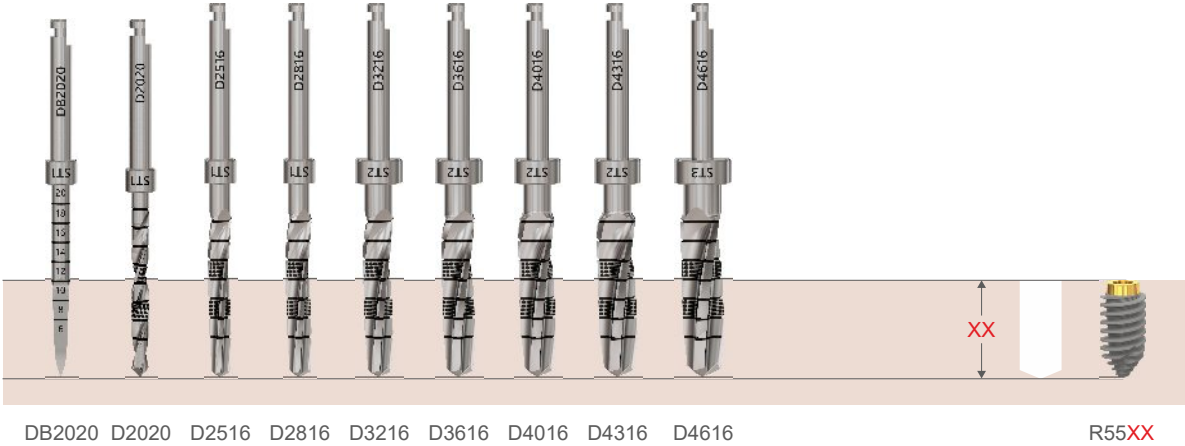

D2-D3 BONE

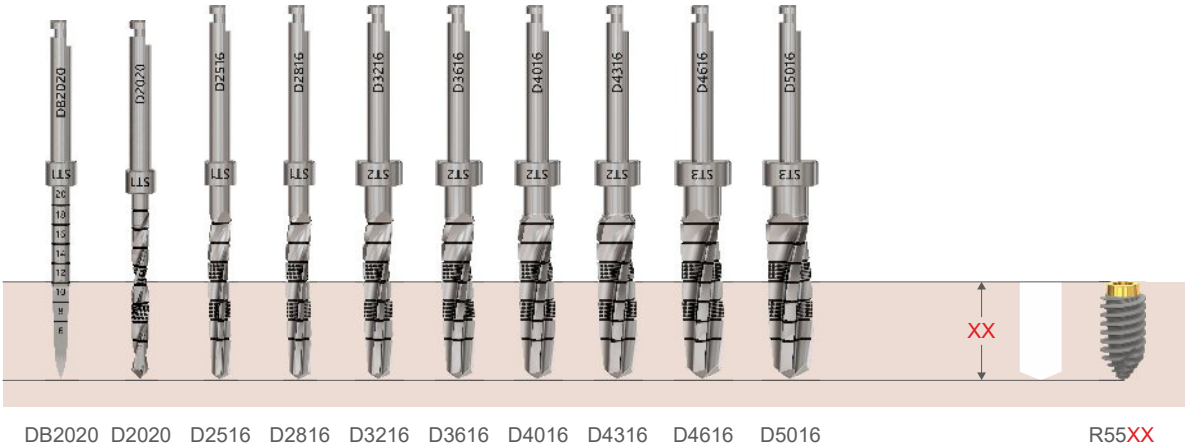

D1 BONE

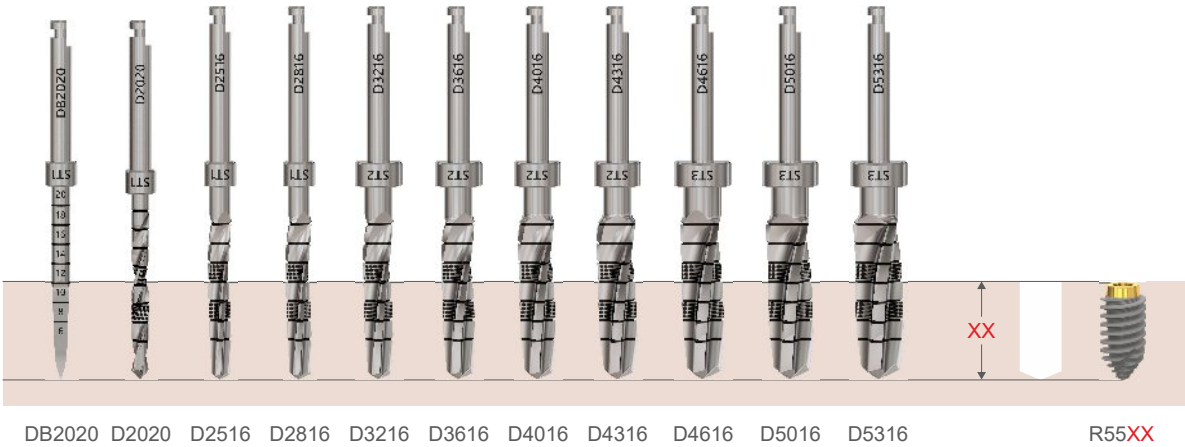

Here xx is the length of the implant, mm

ROOTT **R** implants installation using tapered drills

Implant	D4 BONE	D2-D3 BONE	D1 BONE
Ø 3.0 mm	DB2020	DB2020	DB2020
	D2020	D2020	D2020
		D2516	D2516
			D2816
Ø 3.5 mm	DB2020	DB2020	DB2020
	D2020	D2020	D2020
	D2516	D2516	D2516
		D2816	D2816
		D3216	
Ø 3.8 mm	DB2020	DB2020	DB2020
	D2020	D2020	D2020
	D2516	D2516	D2516
	D2816	D2816	D2816
	D3216	D3216	
		D3616	
Ø 4.2 mm	DB2020	DB2020	DB2020
	D2020	D2020	D2020
	D2516	D2516	D2516
	D2816	D2816	D2816
	D3216	D3216	
		D3616	
Ø 4.8 mm	DB2020	DB2020	DB2020
	D2020	D2020	D2020
	D2516	D2516	D2516
	D2816	D2816	D2816
	D3216	D3216	
	D3616	D3616	
	D4016	D4016	
		D4316	
Ø 5.5 mm	DB2020	DB2020	DB2020
	D2020	D2020	D2020
	D2516	D2516	D2516
	D2816	D2816	D2816
	D3216	D3216	
	D3616	D3616	
	D4016	D4016	
	D4316	D4316	
	D4616	D4616	
		D5016	
		D5316	