

ITEM NO.	PART NUMBER	DESCRIPTION	QTY.
1	12114-TLINE-02	"H" Intermediate Insulator Spacer Bar	2
2	12114-TLINE-04	"H" Spacer Insulator	2
3	12114-TLINE-03	Aluminum Spacer Bar Clamp	4
4	91757A105	#8 Lock Washer, Internal Tooth SS	8
5	91772A199	8-32 x 1" Machine Screw Pan Head Phillips	8
6	91757A109	1/4 Lock Washer, Internal Tooth SS	4
7	92240A544	1/4-20 x 1-1/4" Screw Hex Head Cap	4

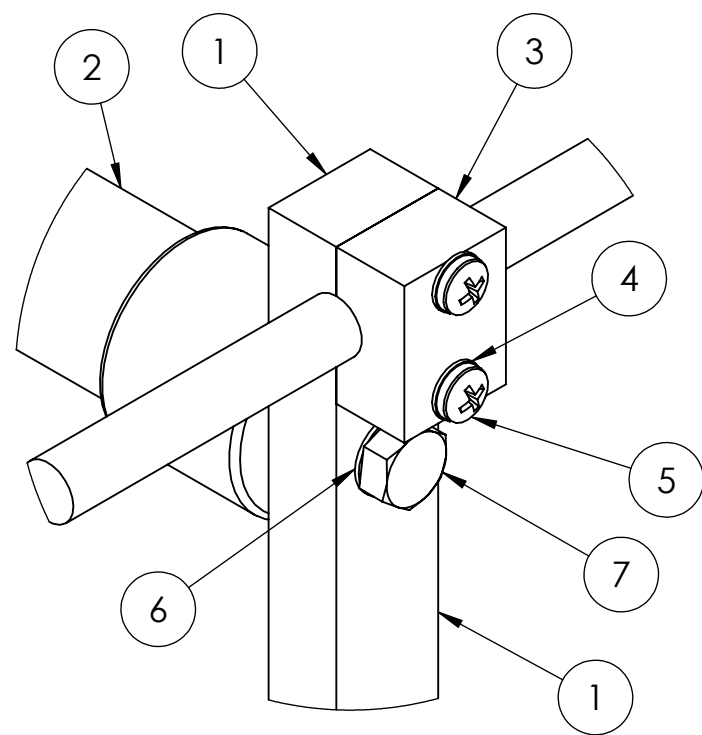

**DETAIL A**  
SCALE 1 : 1

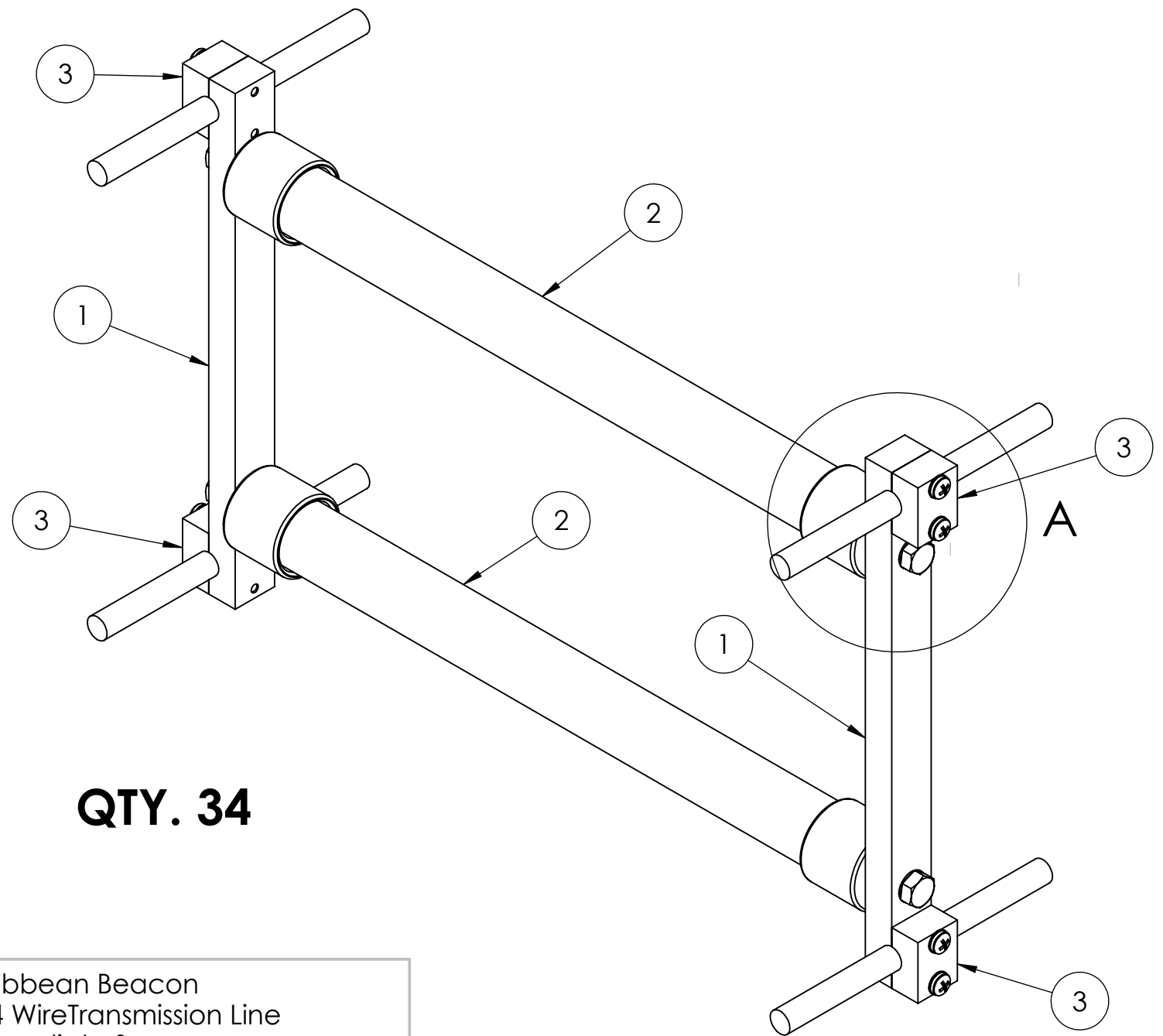

**QTY. 34**



**KINTRONIC LABORATORIES INC.**  
BLUFF CITY, TN.

COPYRIGHT 2017 KINTRONIC LABORATORIES, INC.

Scale:  
1:2

Title:  
Caribbean Beacon  
300 Ohm 4 Wire Transmission Line  
Intermediate Spacer

Rev:	Rev. Description:	Rev. Date:	Job No. 115099	Designed:
Dwg No: 12114-TLINE-05	Ref Dwg	Date 12/8/2017	Drawn: M. Kistner	Approved:
			Sheet 1 of 2	

THE CONTENTS OF THIS DRAWING ARE THE INTELLECTUAL PROPERTY OF KINTRONIC LABS, INC. AND ARE NOT TO BE DISTRIBUTED TO ANY THIRD PARTY WITHOUT THE WRITTEN CONSENT OF KINTRONIC LAB, INC.

MATL:

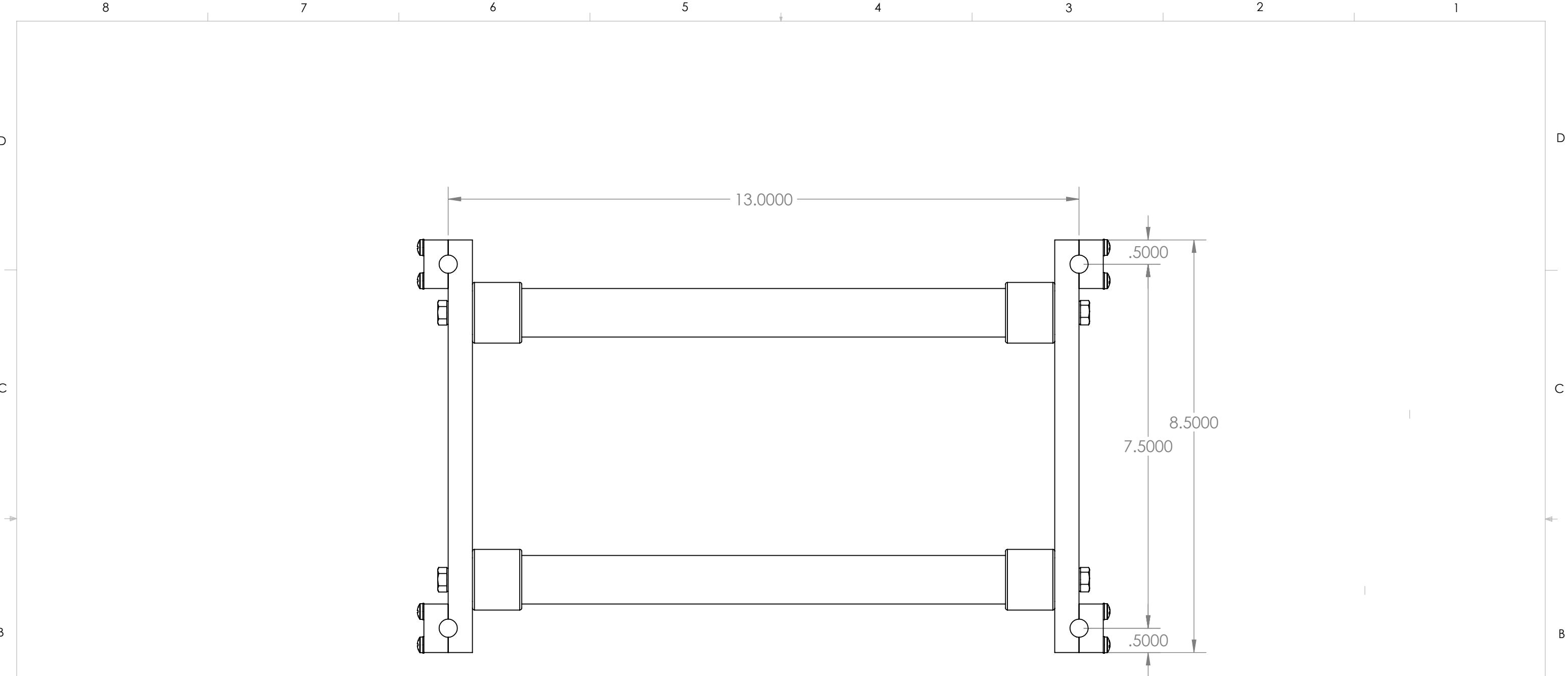

**KINTRONIC LABORATORIES INC.**  
BLUFF CITY, TN.

COPYRIGHT 2017 KINTRONIC LABORATORIES, INC.

Scale:  
1:2

Title:

**Caribbean Beacon**  
**300 Ohm 4 Wire Transmission Line**  
**Intermediate Spacer**

Designed:

Job No.  
115099

Approved:

Drawn:  
M. Kistner

Sheet  
2 of 2

THE CONTENTS OF THIS DRAWING ARE THE INTELLECTUAL  
PROPERTY OF KINTRONIC LABS, INC. AND ARE NOT TO  
BE DISTRIBUTED TO ANY THIRD PARTY WITHOUT THE  
WRITTEN CONSENT OF KINTRONIC LAB, INC.

MATL:

Rev:

Rev. Description:

Rev. Date:

Date

Dwg No:

Ref Dwg

Date

Drawn:

Approved:

Sheet

12114-TLINE-05

12/8/2017

M. Kistner

2 of 2