

PAT TECHNOLOGY SYSTEMS

# FILTRABOX

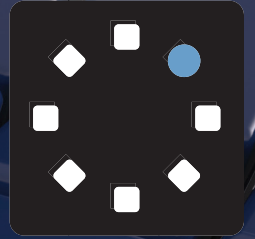

PREMIUM ENGINEERED FUME EXTRACTORS

FOR:

## BOSSLASER

MODULAR FOR SERVICEABILITY

HIGH CAPACITY

LOW OPERATING COST



# Specifications

## Compact

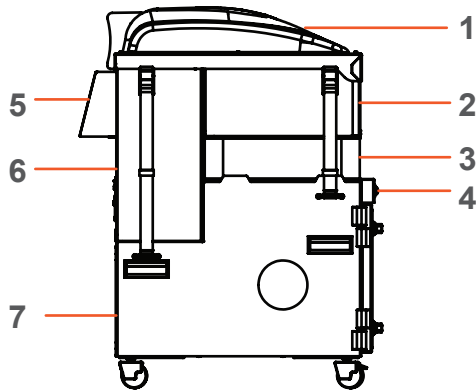

### Technical Specifications

Quiet operation	50 dB
Max airflow	210 CFM
Height	31 in.
Width	21 in.
Depth	25 in.
Glassfiber pre-filter capacity	7 m <sup>2</sup>
Glassfiber HEPA filter capacity	6 m <sup>2</sup>
Carbon filter capacity	1x41 lbs
Voltage	230/120 V
Frequency	50-60 Hz
Wattage	1.1 kW
Warranty	1 year

## Expand 1

Single Blower

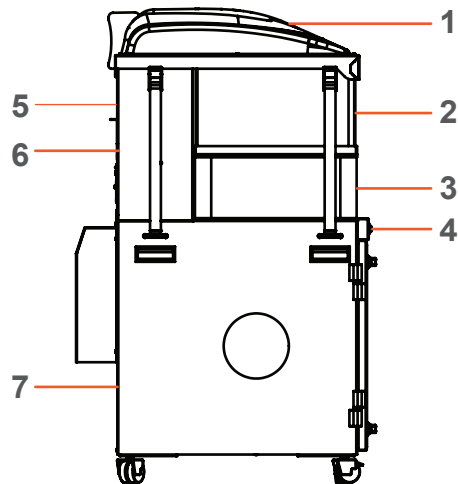

## Expand 2

Dual Blower

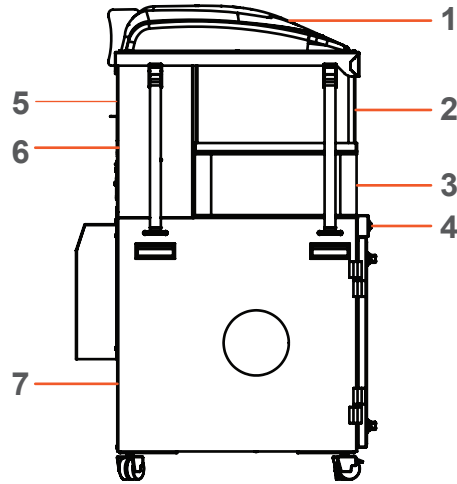

### Technical Specifications

Quiet operation	50 dB
Max airflow	210 CFM
Height	44 in.
Width	29 in.
Depth	28 in.
Glassfiber pre-filter capacity	30 m <sup>2</sup>
Glassfiber HEPA filter capacity	12 m <sup>2</sup>
Carbon filter capacity	2x41.5 lbs
Voltage	230/120 V
Frequency	50-60 Hz
Wattage	1.1 kW
Warranty	1 year

### Technical Specifications

Quiet operation	53 dB
Max airflow	2x210 CFM
Height	44 in.
Width	29 in.
Depth	28 in.
Glassfiber pre-filter capacity	30 m <sup>2</sup>
Glassfiber HEPA filter capacity	12 m <sup>2</sup>
Carbon filter capacity	2x41.5 lbs
Voltage	230/120 V
Frequency	50-60 Hz
Wattage	2.2 kW
Warranty	1 year

### Legend:

- |                          |                      |                               |                          |
|--------------------------|----------------------|-------------------------------|--------------------------|
| 1) Lid Module w/ sensors | 2) Oxy-Carbon Filter | 3) Rigid Aluminum Hepa Filter | 4) User Interface Module |
| 5) Electronics Module    | 6) Blower Module     | 7) Pre-Filter Housing/Chassis |                          |

For more information please call Filtrabox™  
at +1 514-840-9696 (Local)  
or +1 877-582-7929 (International)