

Q-CATCH®

87 SERIES



 **ARROWQUIP**

WHY ARROWQUIP?

Introducing the new era of cattle handling equipment – the 700 Series. Taking limitless cattle handling to the next level, Arrowquip's newest line of equipment has a solution for every kind of rancher. With infinite options and configurations to choose from, you're guaranteed to achieve maximum efficiency no matter what your operation needs.

MODEL: DELUXE VET [8700]

WEIGHT: 2710 lbs.

DIMENSIONS: 55" w x 95" h x 135" l

MODEL: STANDARD [8700MR]

WEIGHT: 1730 lbs.

DIMENSIONS: 55" w x 95" h x 95" l

PROPER HANDLING MEETS PRECISION ENGINEERING

Arrowquip's **NEW** Q-Catch 87 Series manual cattle chute takes quiet cattle handling to the next level with features like the **NEW** heavy-duty structure and **NEW** direct drive head gate system. Engineered with purpose and precision, every feature in the Q-Catch 87 Series is designed to boost your operation's efficiency through the application of low-stress cattle handling concepts and innovation. From the rubber floor and poly composite rump fingers to the **NEW** poly-coated slam latches and **NEW** poly bushings on hinge points, the Q-Catch manual cattle chute still continues to hold the title for the quietest manual cattle chute ever manufactured.

PRODUCT WARRANTY

- Manual cattle chute - **7 YEARS**
- Patented head gate friction locks – **LIFETIME**
- Patented squeeze friction locks – **LIFETIME**
- Rump fingers – **LIFETIME**
- Rubber floor – **LIFETIME**

Products must be registered to claim warranty. Contact your Authorized Arrowquip Dealer for more information.

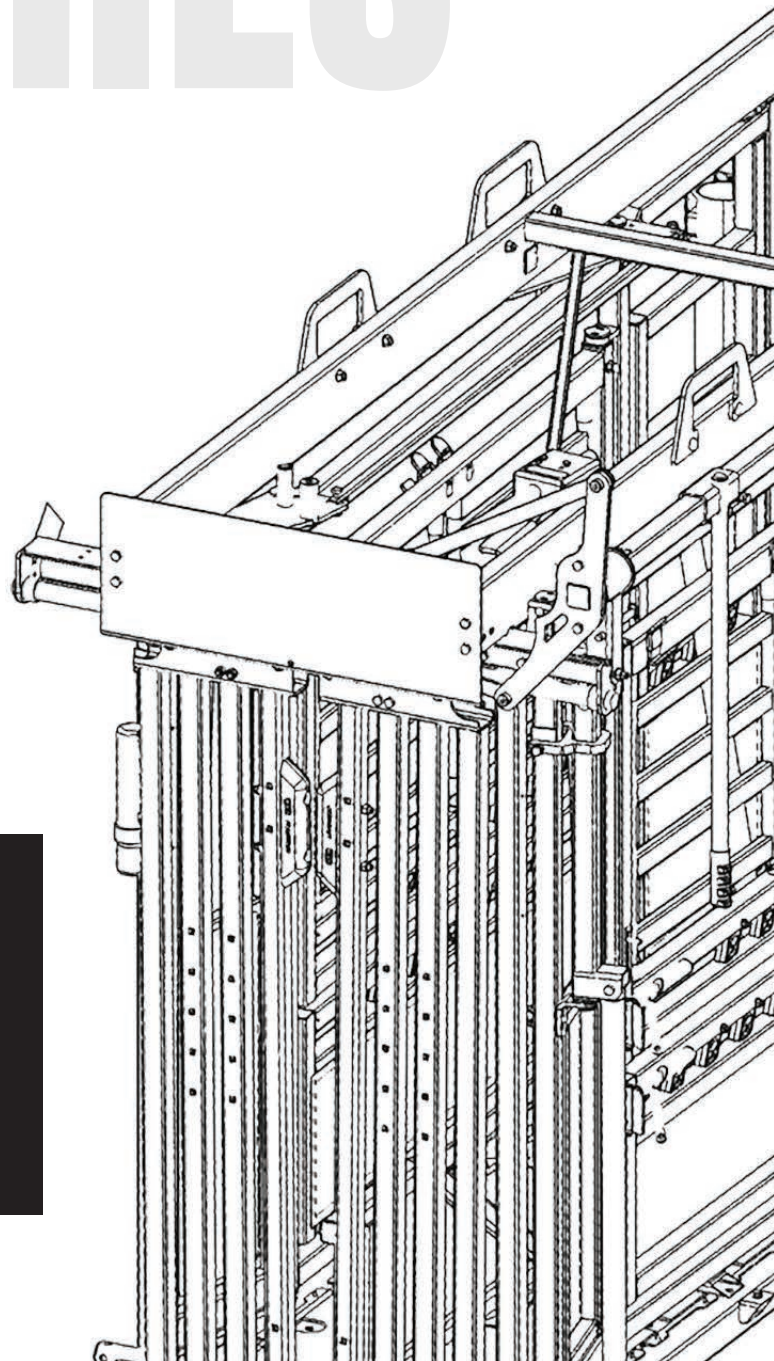

CHOOSE



Q-CATCH® 87 SERIES DELUXE VET [BELOW]

If you want maximum cattle control, versatility, and freedom in your cattle chute, look no further than the Deluxe Vet. The vet cage provides a safe location for handlers and vets to complete preg checks, AI, and many other essential tasks. This chute takes your livestock management to the next level with a full-length dual parallel squeeze, allowing you to squeeze the entire chute down before cattle enter it, so there is no point within your system that a cow or calf can turn around.

Q-CATCH® 87 SERIES STANDARD [ABOVE]

Working with limited space? The Standard Model of the Q-Catch 87 Series allows you to work your cattle in the most safe and effective way possible, even if you cannot fit a full-sized chute and vet cage into your yard. Including all the standard features of the Q-Catch 87 Series, and a variety of add-ons designed to increase your productivity, the Standard is an effective option for operations where space is limited.



EVEN QUIETER

- Q1** NEW poly-coated slam latches
- Q2** NEW poly bushings on all pivots and hinges, including access gates and vet doors
- Q3** Patent-pending flooring made with true virgin rubber from Goodyear®
- Q4** Caulking on all sheet metal panels
- Q5** Two rows of nylon rump fingers
- Q6** Includes rubber-coated fiberglass rump bar



3E Q-CATCH HEAD GATE [PATENTED]

- Uses light to draw cattle into the chute
- **NEW** barred style allows cattle to see light past the head gate
- Patented locking mechanism features infinite adjustments
- Self-lubricating head gate rollers are maintenance-free
- Opens to a full 30" top to bottom
- Single lever push-to-close, pull-to-open operation never requires adjustments

ROLLING TAIL GATE

- Reversible offside & onside operation
- Top-mounted to eliminate the issue of build-up



NEW DIRECT DRIVE SYSTEM [PATENT-PENDING]

- Enhanced design provides a direct connection from the control tube to the head gate
 - Provides instant head gate response time
 - Head gate operation can be easily converted* to the opposite side
- *Requires additional parts. See product manual.

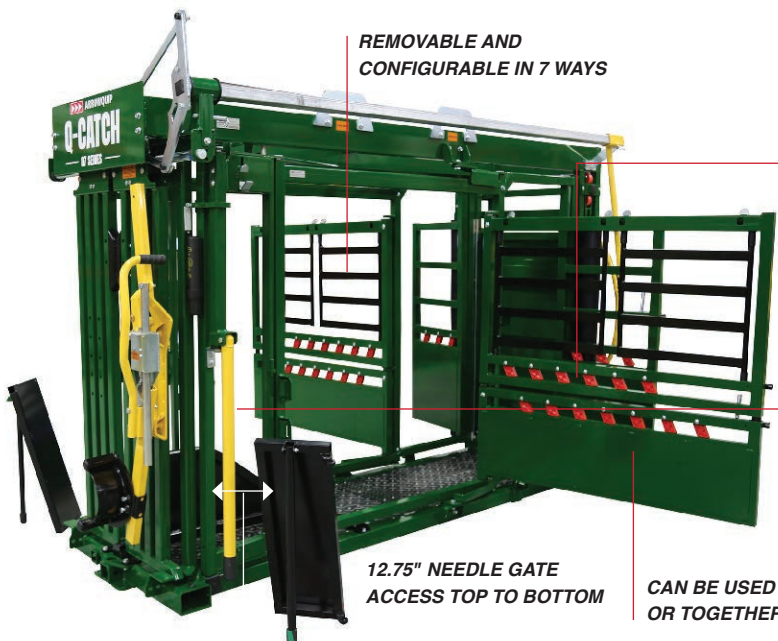

REMOVABLE AND CONFIGURABLE IN 7 WAYS

TWO ROWS OF RUMP FINGERS

- Second row of rump fingers on the bottom door enhance the ability to handle small calves
- Nylon rump fingers designed to endure high pressure
- Heavy-duty rubber-coated fiberglass rump bar that is light to use and does not slip

NEEDLE ACCESS [PATENT-PENDING]

- **NEW** drop-down needle bar allows for quick access to the neck

12.75" NEEDLE GATE ACCESS TOP TO BOTTOM

CAN BE USED INDEPENDENTLY OR TOGETHER



SQUEEZE

- Single lever push-pull operation
- Designed to work with cattle of any size
- Patented squeeze mechanism never requires adjustments

FLOORING [PATENT-PENDING]

- Maintenance-free, molded rubber flooring
- Quietest flooring system on the market today
- Fully replaceable



PORTABILITY

- Transport-ready with the **NEW** wheel kit add-on
- **NEW** 3" x 3" beams provide a durable structure for transportation

HEAD GATE OPERATION HANDLE

- User-friendly handle that reduces operator's fatigue
- Handle can be situated anywhere along the side of the chute



MOUNT BRACKETS

- Allows you to place the chute on load bars for weighing cattle
- Can be used to secure the chute to the ground with bolts

VET DOOR

- Swings 180° in and out of the chute
- Raised vet door height by 2"
- Improved slam latch ensures the door will not swing through when slammed shut

SWINGS 180° IN & OUT

ADD-ONS



NEW WHEEL KIT

You can easily transport your cattle chute to another site with the new wheel kit. The wheel kit comes with two manual jacks, an adjustable hitch, a jack adaptor for the hitch, and two 14" tires.



NEW STERNUM BAR

The sternum bar prevents cattle from going down in the chute. The improved design is sheeted to prevent hoof traps, and is easily installed or removed with 2 bolts.



NEW 3RD GENERATION HEAD HOLDER [PATENTED]

The head holder is a sturdy mechanism that clamps around the animal's neck and holds the head immobile. The head holder features single-lever push pull operation, and simplifies any procedure requiring access to the animal's head. The **NEW** 3rd generation head holder is more heavy-duty than previous models, and features new mechanical connections.



NEW TRIMMING BAR

The trimming bar provides added safety when clipping cattle. You can adjust the position and angle of the bar along the side of the chute to suit your needs.

Arrowquip was founded in 1988 by the Firth family in Australia with the mission "To influence the livestock handling industry globally through the practical application of animal science and welfare standards, and increase producer safety and profitability with innovative equipment". This inspiration came while working cattle on their family ranch in Australia, due to the challenges they encountered with the lack of quality livestock handling solutions available to ranchers. As a forward-thinking family, they began to develop solutions to fill this gap in the market, and have been providing the high-quality livestock handling equipment producers are seeking ever since.

Arrowquip is the only manufacturer to employ a full-time team of engineers dedicated specifically to cattle handling in our industry. Every

piece of equipment we develop undergoes an extensive development period in which our R&D Team exhausts every possible avenue to make our equipment the best it can be for the handler to work their livestock. As a result, our equipment is recognized worldwide as the most innovative and thoughtfully designed livestock equipment in the market today.

In the last 30 years, Arrowquip has become a world-renowned manufacturer of cattle handling solutions known for their innovative designs, technological advancements, investment in animal science, and forward-thinking equipment. Our years of research, equipment development process, extensive testing periods, and the refusal to settle for "good enough" have set a new precedent within the livestock handling industry.

