



# Lumberjack Grant Application

## PROJECT TITLE: Friends of Townline Lake Park Combination ADA Fishing Pier/Kayak Launch

Submitted by (name):	<b>Dave Schmitz, Fundraising Chairperson</b>
Organization:	<b>Friends of Town Line Lake Park</b>
Address:	<b>3808 Townline Lake Rd, Rhinelander, WI 54501</b>
Phone:	<b>715.499-2018</b>
Email:	<a href="mailto:dschmitz@newnorth.net"><b>dschmitz@newnorth.net</b></a>
Counties:	<b>Oneida</b>

**Mission Statement:** *Lumberjack Resource Conservation & Development Council, Inc., a multi-county, nonprofit in Northeastern WI, strives to enhance area natural resources, promote a higher standard of living and improve the quality of life for area citizens by fostering partnerships between public and private sectors and strategically investing in area natural resources.*

### SUMMARY:

Review the Lumberjack Mission Statement above. How does your project align with Lumberjack’s mission? Be specific. The more alignment points, the better your project is viewed.

**Answer:** This project aligns on several levels. First, there are no public fishing piers on Town Line Lake and this project would enhance the natural resource by giving two more safe recreational opportunities for the lake: a safe ADA-compliant canoe/kayak launch and a safe ADA-compliant fishing pier. Second, Town Line is a small lake and perfect for canoeing/kayaking, but the landing is rocky, has areas with debris and is unlevel. Giving those with disabilities or limitations the opportunity to launch and fish safely on a smaller, less crowded lake would add immensely to their quality of life. Third, our group, Friends of Town Line Lake Park (FTLLP) has already fostered both public and private partnerships including the Oneida Co Bike & Walking Trails Council, Rhinelander Area Silent Trails Association, Northern Paddle Club, Newbold Outdoor Recreation Committee, Oneida County Forestry Department and Committee, WDNR, Oneida County Land/Water Conservation. We have also moved several area corporate foundations to strategically invest in our project by helping them see our vision that this pier and launch is a fantastic way to strategically invest in our area natural resources because it would bring more people to our area. For these reasons, our project aligns well with your mission.

### OBJECTIVES:

What problems, concerns or opportunities will this project address? You will be asked to show how your objectives were met when you present your follow-up presentation to the Council.

**Answer:** There are very few natural parks left like Town Line Lake Park so this project creates a huge opportunity to enhance the resources at this natural serene lake, just a mile from town. Also, there are NO ADA-compliant amenities at Town Line Lake Park, in fact there are NO ADA-compliant kayak launches in Oneida County, this would be the first one. This park would be perfect for the kayak launch because it is a small lake with little current so kayakers can take full advantage of wildlife viewing. They’ll see heron, eagles, otters, loons, deer, songbirds, and be able to fish for crappie, blue-gill, perch, large-mouth bass, and the occasional northern if you’re lucky. As described above, there is currently only shore fishing and with an uneven shoreline, it can be dangerous. A safe fishing pier would alleviate concerns for those with disabilities or those unsteady and allow them the freedom to fish a great, healthy lake. Another concern is the unsafe boat launch for canoes/kayaks. There is not a good level spot to launch and there is debris in area. Providing an ADA-compliant, safe, secure, and accessible launch would provide the opportunity for more people to recreate on the lake. At the end of the application are a rendering and a quote. Our budget also includes two signs. Following current signage statutes, we will place two interpretive signs at the head of the path and then at the gangway or on the pier. Our hope with the interpretive signs is to create

excitement and an overall Town Line Lake Park experience by highlighting the healthy ecology of the lake and drawing on the need for serene recreational spots.

We are often asked why we are raising funds to care for and improve a county park that should be paid for with tax dollars. Even though this is a public park owned by Oneida County, in 2020 they were finalizing plans to sell the most desirable portions of the park to offset the cost of another property slated for public use. With the other parks the county funds, there was nothing left to care for Town Line Lake Park so they chose to divest and then sell. Town Line Lake Park has been a county park for more than 100 years and holds historic and generational ties to the community. The community spoke up and made it known they wanted to keep this park. Our group Friends of Town Line Lake Park formed to stop the sale. Because of our efforts, in May of 2021 something historic happened at the Oneida County Board Meeting. Every member of the Oneida County Forestry & Recreation Committee voted against their own resolution to sell the park and joined every other county board member in a unanimous vote to keep historic Town Line Lake Park! Even though the park sale was stopped, the board made it clear that didn't mean there would be any budgeted funds to maintain or improve it. There came the understanding that any

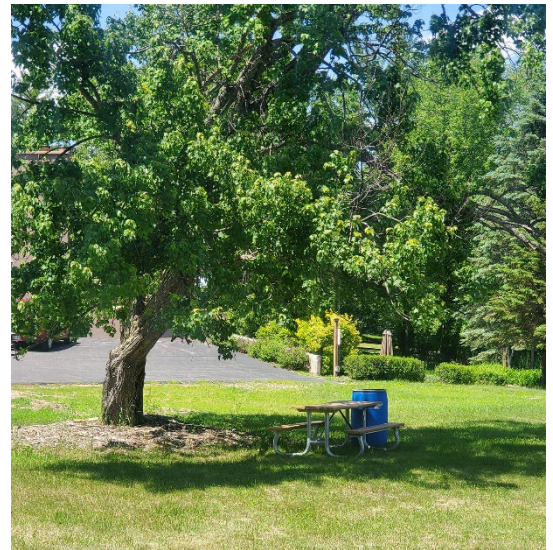

improvements/amenities for the near future would have to be sought outside of the county budget so now FTLLP has a contract with the County stating we will maintain the park and fundraise for any improvements. Above is a picture showing how our efforts paid off in the summer/fall of 2022. With generous community support, we were able to raise enough money to place picnic tables, trash cans and porta pots for the first time in over a decade. Eventually we hope to establish enough use to show the county that their budget should include this park. In the meantime, we have successfully engaged the community and are looking forward to installing the first of its kind in Oneida County, kayak launch in combination with a fishing pier – see attached rendering.

## FORMULATION & EVALUATION:

Why is this project the best way to address the issues described above? How will the outcome be evaluated? Be specific – outcomes that can be measured are viewed more favorably.

**Answer:** Combining the fishing pier/kayak launch is more efficient than trying to build one of each. There currently are no ADA-compliant kayak launches in Oneida county and no amenities at Town Line Lake Park so installation in the Spring of 2023 will be the most measurable outcome. It would also create better accessibility for all. Our group understands the importance of public engagement and will survey the users. Other outcomes will be measured by documenting pier/launch use post-installation.

## ASSISTANCE NEEDED:

Why is assistance needed from Lumberjack? Who within your organization will run the project? Describe the assistance you are receiving from other partners. Include Letters of Support as outlined in Lumberjack's Granting Policy.

**Answer:** Our group organized in February of 2021, incorporated on 6/23/2021, received WI Charitable status on 7/22/2021 and IRS 501c3 status on 11/30/2021. We have a diverse board of directors with the skills needed to organize and implement projects. David Schmitz is the current chairperson of our fundraising committee and is the contact person for this grant. He will lead the other members of our board, along with community help, in following through with this project. Because we are a small, newly formed group, we are coming to Lumberjack because it is one of the few organizations that helps smaller groups with projects such as this. At the end of August 2022, the FTLLP started fundraising efforts. Since then, we've received generous donations totaling \$20,872 (please see budget sheet.) The FTLLP Board of Directors is committing another \$1,500 toward this project. The Oneida County Forestry Department has agreed to help with some initial maintenance at the site and to remove any over-winter items to shore. Supporting us with grants and donations are The Rhinelander Community Foundation, GBU Life Matching Funds Program, Walmart Foundation, Nicolet National Foundation and WPS Foundation. In addition, we've raised a significant sum through events, online donations & jug donations (see picture above of our board at Oktoberfest in Rhinelander in September of 2022.) We are asking the



Lumberjack Council for a \$10,000 grant. The Council would reap almost immediate benefit by funding this project because with the combined donations, we would be able to form installation plans as soon as February 2023, grade the path as soon as weather permits in the Spring and install the pier by Mid-May 2023. With your donation, we'd be able to come back to your October 2023 meeting and present our 1<sup>st</sup> season's usage figures.

## **PROJECT OUTLINE & TIMETABLE:**

List the project steps and expected completion dates. Could there be any possible roadblocks? If so, list them here.

### **Answer:**

Summer/Fall 2022: Begin fundraising campaign & apply for funding from community groups/businesses

Nov/Dec 2022: Complete Lumberjack Application

Dec 2022: Present Lumberjack Grant Proposal to the Oneida County Conservation Committee and submit to Lumberjack before 12/31 deadline

January 2023: Attend and present project to Lumberjack Council

Jan-March 2023 – Continue fundraising efforts

Feb-April 2023 – Complete Installation Plan

May 2023 – Ribbon Cutting Ceremony/Pier Installation

May – end of 2023 season – Observe, survey & document use

October 2023 – present usage figures to Lumberjack Council

Roadblocks: Timing of all the different types of grants can delay projects but we feel we've planned well enough and have received enough funds to be able to proceed. We've already made a \$5,000 down-payment to Crandon Docks and receiving the Lumberjack grant would seal the deal. You'd see immediate results/benefits of having this amenity available to Oneida county residents of all abilities.

**BUDGET:** Complete the attached Budget Form. Remember the 50% match value requirement with 15% of the match being cash. List each match donor in the 'Match' column and submit a corresponding Letter of Support with specific value of in-kind/services or cash for the project for which funds are being asked. Note: This form is available in excel online at: <https://lumberjackrcd.org/projects>

See next page for budget...

---

### Attachments:

Budget

Dock Quote/Rendering

Installation site picture

Letters of Support

✓ Rhinelander Community Foundation

✓ GBU Life Matching Funds

✓ WPS Foundation

✓ Friends of Town Line Lake Park's donation of \$1,500 + \$4,122 in savings from fundraisers

✓ Walmart Foundation

✓ Nicolet National Foundation

# LUMBERJACK BUDGET FORM



Project Name: FTLLP ADA Accessible Fishing Pier/Kayak Launch

Starting Project Date  
2/1/2023

Ending Project Date **1**  
12/31/2023

Income (SPECIFY)	Cash	Match (Cash & In-Kind) <b>2,3</b>	Total
YOUR Request of Lumberjack RC&D	\$ 10,000.00		\$ 10,000.00
Rhineland Community Foundation		\$ 5,000.00	\$ 5,000.00
GBU Life		\$ 5,000.00	\$ 5,000.00
Wisconsin Public Service Foundation		\$ 5,000.00	\$ 5,000.00
FTLLP		\$ 1,500.00	\$ 1,500.00
Fundraising-Events, Donor Box & Jugs (In Savings)		\$ 4,122.00	\$ 4,122.00
Walmart Foundation		\$ 750.00	\$ 750.00
Nicolet National Foundation		\$ 1,000.00	\$ 1,000.00
		\$ -	\$ -
<b>Total Income</b>	\$ 10,000.00	\$ 22,372.00	\$ 32,372.00

Percent of Match=Match Total/Lumberjack Request 224%

LJ Percent of Total = YOUR LJ Request/Total Expenses 31%

General Expenses (SPECIFY & include Match expenses)		
Crandon Docks (See attached quote)	\$	27,108.00
Grade Path to Lake approx 34 hrs @ \$100/hr	\$	3,400.00
Interpretive Signs (2) Geneis Graphics \$900 ea	\$	1,800.00
Hardware/Lumber for signs	\$	64.00
Expense Item	\$	-
Expense Item	\$	-
Expense Item	\$	-
Expense Item	\$	-
<b>Total Expenses</b>	\$	32,372.00
<b>NET <b>4</b></b>	\$	-

- 1** Lumberjack Project funds are available for one year from the date of the approval notice
- 2** Match Value must equal at least 50% of the Lumberjack Request and 15% must be in cash  
Volunteer Services=\$15/hour & Professional Services=current hourly wage
- 3** A Letter of Support is required for all match partners listed above and must include a description and value of service.
- 4** Explain a **NET** balance other than Zero (\$0.00) in the box below:

QUOTE/RENDERING: Crandon Docks & Lifts dated 11/30/2022

ADA Compliant, Combination Fishing Pier/Kayak Launch  
 Shore of Town Line Lake, Hwy K, Rhinelander, WI



# EZ DOCK FLOATING DOCK SYSTEM

Cars & Docks, LLC

8227 County Hwy. DD, Pickerel, WI 54465  
 Bob - 715-484-2277 • 715-219-4434

Part #	Description	Qty.	Price	Total
	ADA			
200900	EZ Kayak Launch	1	2213 <sup>00</sup>	2213 <sup>00</sup>
208010	Dock Section	2	2779 <sup>00</sup>	5558 <sup>00</sup>
301100	Coupler	6	72	432 <sup>00</sup>
	Trans Bench + Sign	1	6205	6205 <sup>00</sup>
210350	HD Pipe Brackets	4	489	1956 <sup>00</sup>
210350	3.5" OD Pipe	3	509	1527 <sup>00</sup>
	Curbing	3	260	780 <sup>00</sup>
	3' Flat Head Stainless Screws	18	6	108 <sup>00</sup>
	Keelway 4' x 16'	1	4896	4896 <sup>00</sup>
6200460	" " to Float	1	533	533 <sup>00</sup>
6200450	Trans Plate 4'	1	1300	1300 <sup>00</sup>
	Del + Equipment	1	1600 <sup>00</sup>	1600 <sup>00</sup>

Name Friends of Town Line Lake  
 Address 6012 City K  
 City Rhinelander, WI  
 Phone 715-369-9886 Cell 715-401-2478  
 Date 11-23-2022  
 Location Tracy Beckman

Freight	
Total	27,108 <sup>00</sup>
Tax	Need Tax #
Amount	27,108 <sup>00</sup>

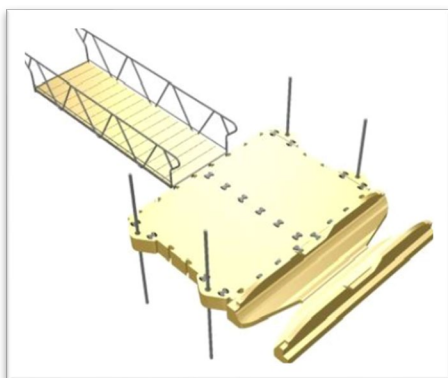

3D Image of Pier

See next page for design specifications

Dock Live Load of 62.5 lbs/sqft  
Low Profile Dock Live Load 30 lbs/sqft

MADE IN  
USA

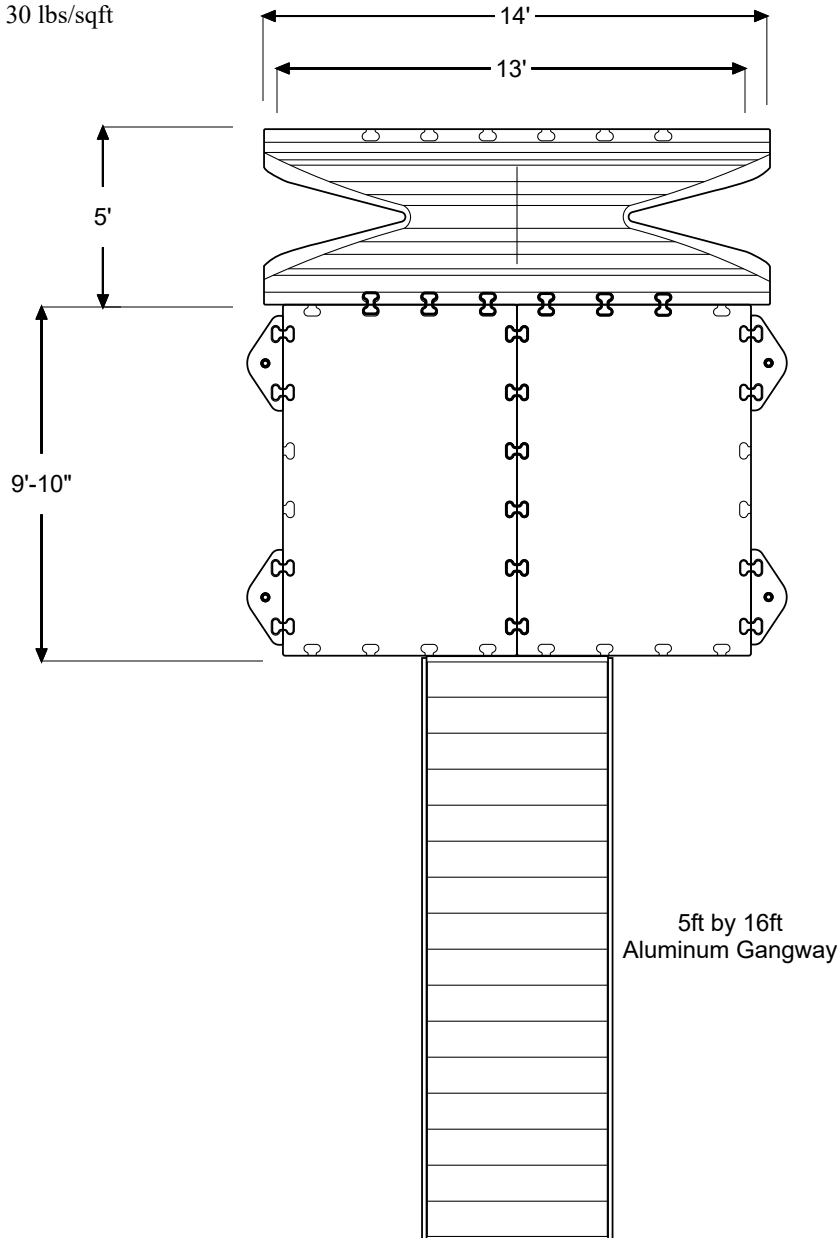

**Project Name:**

Friends of Townline  
Rhineland, WI

**Distributor Name:**

Justin Lance  
ABC Boat Docks  
(701) 751-8484

Drawn by: Justin Lance

Date: 11/30/2022

DWG Name: ABC\_44895534513

EZ Dock, Inc

878 East Highway 60

Monett, Missouri 65708

Phone: 1 (800) 654-8168

Fax: (417) 235-2232

**General Notes:**

1. This drawing does not reflect anchoring. Once sufficient information & completed Proposal Request Form concerning water and bottom conditions is received, anchoring may be detailed.
2. Note: It is the dock owner/operator's responsibility to ascertain and comply with all applicable Federal, State, and local laws, ordinances and regulations, as well as all inspection, permitting and licensing requirements pertaining to the installation, application and use of EZ Dock products on the owner/operator's premises. EZ Dock, Inc. assumes no duty or responsibility with respect to the legality or compliancy of the owner/operator's chosen installation, application or use of EZ Dock products.
3. Reference EZ Dock Owner Manual for additional details.

NOTICE! Read EZ Dock Limited Warranty carefully. Among other things, EZ Dock does not warrant damages, failures or defects caused by unauthorized modification of EZ Dock Product, and/or unauthorized attachment to/of EZ Dock Product.



Path to lake 

Pier 

Signage 

Fireside Supper Club  Path to pier/pier shoreline location Fireside Supper Club

6018

6000

6018

6012

K

K

K

K

K

Google

5985





# RHINELANDER COMMUNITY FOUNDATION

April 4, 2022

Friends Of Town Line Lake Park  
Attn: Tracy Beckman  
3808 Townline Lake Road  
Rhineland, WI 54501

Dear Ladies and Gentlemen of Friends of Townline Lake Park,

Congratulations! The Board of Directors of the Rhineland Community Foundation (RCF) has reviewed your grant application and approved a grant to your organization in the amount of \$5000. *The funds will be held in reserve with a contingency that the remaining funds are raised.*

The grant funds are designated for the charitable purpose of:

**Access for All-Townline Lake ADA Fishing Pier/kayak launch**

*Please contact the Rhineland Community Foundation when your organization can demonstrate additional funds are raised and the project is in reach; we can then release grant funds for this project.*

You are invited to the Business After 5, at the Rhineland Country Club, 5-7pm.

We appreciate the opportunity to partner with your organization in strengthening our community.

Kindest Regards  
  
Gina Heck  
Rhineland Community Foundation



# GBU Life \$5K Matching Information

----- Forwarded Message -----

**From:** Elliott, Kenneth <kenneth.elliott@gbu.org>  
**To:** dschmitz@newnorth.net <dschmitz@newnorth.net>  
**Sent:** Tuesday, December 6, 2022 at 10:17:38 AM CST  
**Subject:** RE: Give Back Group Fundraiser Request

Hi, David, Congratulations on such a successful fundraising campaign. I'm sorry that I am following up on this so late. If you haven't already send a check for the total amount raised, you do not have to. The summary you uploaded was enough for me to process the match. Please let me know if you have sent the check to us. I will send our matching check along with your check to Friends of Town Line Lake Park. I am looking forward to seeing pictures in the spring. If I was a little closer, I would love to see all the work that your organization has been doing to improve Town Line Lake Park. GBU is happy that we can support some of your recent projects!

## Ken Elliott

### Charitable Giving and PR Specialist - Fraternal

4254 Saw Mill Run Boulevard | Pittsburgh, PA 15227-3394 | 412.336.3246 | [www.GBU.org](http://www.GBU.org)

**From:** dschmitz@newnorth.net <dschmitz@newnorth.net>  
**Sent:** Thursday, December 1, 2022 10:41 AM  
**To:** Elliott, Kenneth <Kenneth.Elliott@gbu.org>  
**Subject:** Re: Give Back Group Fundraiser Request

Ken, I just submitted the Matching funds For Pier Project for Friends of Town Line Lake Park request via your website. From what I understand you want a check sent to you for the total amount raised so you can send a check back to Friends of Town Line Lake Park? I put a summary of how they raised the funds. We do not have pictures at this point because it is winter here and the dock would be installed in the spring.

Really appreciate your help on this.

David Schmitz 131 Randall Ave, Rhinelander, WI. 54501, 715-365-1746 715-499-2018 cell

On Monday, November 7, 2022 at 11:55:55 AM CST, Elliott, Kenneth <[kenneth.elliott@gbu.org](mailto:kenneth.elliott@gbu.org)> wrote:

Hi, David,  
Got it! You now have 5 GBU members in your Give Back Group making your project eligible for a match of up to \$5,000. How is the fundraiser coming along?

## Ken Elliott, Charitable Giving and PR Specialist - Fraternal

4254 Saw Mill Run Boulevard | Pittsburgh, PA 15227-3394 | 412.336.3246 | [www.GBU.org](http://www.GBU.org)

On Friday, September 2, 2022 at 11:13:21 AM CDT, Elliott, Kenneth <[kenneth.elliott@gbu.org](mailto:kenneth.elliott@gbu.org)> wrote:

Hello, David,

Your Friends of Town Line Lake Park Give Back Group fundraiser request for the Pier Project at Town Line Lake Park by Friends of Town Line Lake Park has been approved. I am trying to verify Paul Schramke's membership. Could you check the spelling of his last name or provide more information so I can verify his membership?

After the fundraiser, the last step in the process is to turn in your final amount for matching, share your story and add pictures.

Visit <https://link.zixcentral.com/u/9bf4cc94/dj3Qg1dc7RGFMUb8W9GfSw?u=https%3A%2F%2Fwww.gbucares.org%2Fgive-back-groups> and under the GBU Matching Donations column, click on "Submit results" under Step 4.

If you have any questions, please don't hesitate to reach out to us.

Thanks,

Ken Elliott

Charitable Giving and PR Specialist - Fraternal

GBU Financial Life | 4254 Saw Mill Run Boulevard | Pittsburgh, PA 15227-3394 | 412.336.3246 | [www.GBU.org](http://www.GBU.org)

MATCH LETTER – WISCONSIN PUBLIC SERVICE FOUNDATION

----- Original message -----

From: WPS Foundation <mail@grantapplication.com>

Date: 9/1/22 4:37 PM (GMT-06:00)

To: tracybeckman@yahoo.com

Subject: Wisconsin Public Service Foundation supports Friends Of Town Line Lake Park Inc

Dear Tracy:

In response to your request, Wisconsin Public Service Foundation is happy to inform you of the following contribution:

Program/Project: Friends of Town Line Lake Park or FTLLP's Access for All - Town Line Lake ADA Fishing Pier/Kayak Launch

Amount: \$5,000.00

We are making this contribution because we believe that together, we can create a brighter future for the communities we serve. The check will be mailed to you shortly.

Any recognition for this contribution should state: Wisconsin Public Service Foundation

We must approve the use of our name and/or logo in promotional materials. If your organization offers social media recognition, you can tag us on Facebook (@WIPublicService), mention us on Twitter (@WIPublicService) or tag us on LinkedIn (@Wisconsin-Public-Service).

Please contact me to request our logo or should you have any questions regarding this contribution.

You also can like us on Facebook (facebook.com/WIPublicService), follow us on Twitter (twitter.com/WIPublicService) and follow us on LinkedIn (linkedin.com/company/wisconsin-public-service).

Sincerely,

Lana Vandervest

Administrator

Wisconsin Public Service Foundation

office: 920-433-1433

Wisconsin Public Service Foundation charitable giving summary:

<https://www.wecenergygroup.com/community/wps-community.htm>

Received \$5,000 check and deposited to FTLLP savings account at RIPCO on 10/27/2022



December 28, 2022

Lumberjack RC&D Council, Inc.  
315 S Oneida Ave, Suite 206  
Rhineland, WI 54501

To Lumberjack Council Members,

At their 8/4/2022 meeting, the Friends of Town Line Lake Park Board of Directors committed \$1,500 toward our pier project to install an ADA Compliant Combination Fishing Pier/Kayak Launch at Town Line Lake Park. Attached are the minutes from that meeting with the motion highlighted in yellow.

Also, let this letter confirm we have been raising funds for this project since August and in addition to the five foundation grants we've been awarded; we have secured monetary donations that are in our savings account and are earmarked for the pier project totaling \$4,122 (\$2552 from Oktoberfest & Music in the Bowl events/\$1,087.10 from our online portal & other individual donors/\$483.38 from various donation jugs placed around town.)

These monies satisfy the \$750 cash match requirement.

Sincerely,

David Walters  
President

# MINUTES – FTLLP BOARD MEETING

FTLLP Board – THURSDAY 8/4/2022 at 5:40PM At Town Line Lake Park & VIA ZOOM

Present: Follenweider, DeMent, Beckman, Schramke, Casey, Schmitz

Excused: Walters, Scheel, Belliveau

Tasks: Follenweider DeMent Beckman Schramke Casey Schmitz

1. Call to Order - The meeting was called to order at 5:50pm by Follendweider
2. Review/Vote to Approve the Agenda – Motion by Casey/DeMent to approve the agenda as presented. Motion Carried.
3. Review/Vote to Approve Minutes of the 7/14/2022 meeting - Motion by Beckman/Schmitz to approve the minutes with noted corrections. Motion Carried.
4. Treasurer’s Report – Members reviewed the financial report which shows a checking balance of \$6,265.35 with restricted funds of \$2,448.51. Regarding restricted funds, noted that there is a difference between ‘restricted’ and ‘earmarked’. Beckman will adjust the financial report to reflect restricted funds and earmarked funds for the next meeting. Motion by Casey/DeMent to approve the financial report with corrections. Motion Carried.
5. Public Input – there was no public input
6. Trails Update – Schmitz said nothing new to report, but he suggested that we connect a trail from Towline Lake Park to Forest Loop Road. Follenweider/Beckman move to approve pursuing this trail. Motion Carried. Schmitz & DeMent will follow up with Forestry to either ask Fiene if ok or have it put on the next committee mtg agenda.
7. Events Update – Oktoberfest 9/10/2022 Beckman explained she paid for a booth at the upcoming event and will donate it to the group if they agree. We could solicit members and pier donations. The group agreed to attend, and Beckman will let everyone know the times. We’ll also bring branded items which is an agenda topic later.
8. Updates/Schedules for mowing, clean up, trash pickup, porta pot cleaning, trash can signs, etc. – Schramke continues to provide most of this work. Trash Schedule: 8/24 Rusty, 8/31 Paul, 9/7 Rusty. There is someone dumping a bag of trash once a week. If it becomes more of an issue, we’ll attempt to learn their identity. Noted that the threat of oak wilt has passed, and Forestry is going to cut the compromised trees in the park. Park Clean Up – Rusty will ask Taylor Prott to help him load raked piles into the back up his pickup and spread them in the woods at the park. Noted that in September we’ll need to schedule leaf pickup, so this fall’s leaves are picked up before the snow flies. One idea is to ask Elliot Boyer to help with this.
9. Picnic Tables frame update: There is a local company that sells picnic table frames \$179. The green treated wood and galvanized hardware would be around \$75 for a total of around \$260 for a picnic table. Follenweider/Schramke moved that DeMent pursue getting approval from Forestry for us to place these picnic tables. Motion Carried.
10. County Forestry Committee
  - Update from 8/3 meeting – Beckman attended and gave a report to the committee. Paul Fiene had nothing to add and thanked the group for their hard work stating it’s looking “really good over there.”
  - Discuss Memorial Trees at Park for approval at Forestry’s September meeting – Linda Casey would like to plant a tree in memory of her son, so Beckman has asked that this item be put on the September committee agenda for approval. It was thought that Fiene may be able to approve this on his own, so we’ll ask. Follenweider feels it could be a program sponsored by FoTLLP where people could donate the tree and we’d have a ceremony. We’d need to know how many trees and what type we can plant. While this program is being pursued, Beckman will find out about the one memorial tree for Linda’s son.
  - Items to discuss with Fiene or to be put on the 9/7 Forestry Committee Agenda: 1) Memorial Trees – permission to plant but need type & how many are allowed (Beckman.) 2) Connected trail from the park to Forest Loop Road (Schmitz & DeMent) 3) Authorization to place \$260 picnic tables (DeMent)



#### 11. Fund Raising Committee

- Meeting Recap – Schmitz reported that Casey is going to get some donation jars at area businesses and the label would contain the QR code. Casey will talk to Trig’s about the requirements/rules for using their fundraiser booth. There are four members currently signed up that are being reimbursed up to \$150/person up to \$1,000 from GBU. J. Beckman, DeMent & Follenweider will sign up, so we earn the rest of the \$1,000.
- Demonstrate donation platform – Follenweider demonstrated the platform and Beckman emailed the code to Casey so she can use it for the donation jars. This QR Code connects to the webpage with our pier fundraiser.
- Pier Fundraiser Update – Beckman
  - i. FTLLP Board \$ Commitment – Schramke/DeMent moved to approve \$1,500 from unrestricted funds be placed in restricted funds for the pier. Motion Carried.
  - ii. Budget – Beckman referred to the budget handout that lists those organizations/businesses that have been or will be approached for grants. The total budget is \$55,258. Since we already have a commitment for \$1,500 from FTLLP, \$1,258 from Crandon Docks & \$5,000 from the Rhinelander Community Foundation, and the Lumberjack grant for \$10K is a pretty sure thing, the amount of the fundraiser will be \$45,000.
  - iii. Motion by Casey/Schramke to approve \$73 plus tax/shipping be placed in earmarked funds for the purchase of a goal thermometer. Motion Carried.

#### 12. Membership

- Approve branded/outreach items – Motion by Follenweider/Schmitz to approve up to \$500 be placed in earmarked funds for the purchase of branded items to be given away upon paid membership and at events. Motion Carried.
- Approve website address, fees and other associated costs – DeMent/Casey moved to have our website be townlinepark.org. Beckman and Follenweider will work on web hosting. Beckman/DeMent moved to place \$100 in earmarked funds to get the website up and running. Motion Carried.
- Approve updated membership documents. Casey/DeMent moved to approve the updated membership form. Motion Carried.
- Approve Membership Drive dates, tasks, recruiting goals all tabled until our next meeting on 9/1

13. Next Meeting Date/Time – Thursday, September 1, 2022, at 5:40pm

14. Future Agenda Items – Events, fall leaf pickup schedule, trails, fundraising, pier, trees, approve membership drive dates, recruiting goals & gifts.

15. Adjourn at 7:23pm.

Submitted by Tracy Beckman, Secretary

## Walmart MATCH LETTER

Community Grant Request ID 76384325, Facility # 1931  
**do-not-reply@cybergrants.com**

To:tracybeckman@yahoo.com,tracybeckman@yahoo.com

Fri, Sep 9, 2022 at 4:41 PM

Dear FRIENDS OF TOWN LINE LAKE PARK INC,

Congratulations! The Walmart Community Grants Team and Facility # 1931 are pleased to inform you that your Community Grant application for Request ID 76384325 has been selected to receive a \$750.00 grant. We are thrilled to support your work in our communities and share your desire to provide local impact.

By receiving this grant, you are part of a long history of Walmart's commitment to giving back to the communities where we operate. In fact, Mrs. Helen Walton used to say "It's not what you gather, but what you scatter that tells what kind of life you have lived."

We encourage you to celebrate this grant publicly! We hope that you will consider doing the following four things:

1. Connect with the store manager who chose to support your local cause and let them know that the grant check arrived safely.
2. Work with the local store manager to announce the grant.
3. Consider sharing the work that our grant supports on social media – our associates and customers like to see the impact we are making in our communities.
4. Review the Grantee Welcome Toolkit at the link below, addressing frequently asked questions (FAQ's), publicity, and outreach options for your consideration.

[http://www.cybergrants.com/walmart/docs/LCC\\_Grantee\\_Welcome\\_Toolkit.pdf](http://www.cybergrants.com/walmart/docs/LCC_Grantee_Welcome_Toolkit.pdf)

The photo release form can be found at the following link:

<http://www.cybergrants.com/walmart/docs/talentrelease2018.doc>

Again, congratulations on your grant award. We are eager to see its impact!

In service, The Walmart Community Grants Team, CG/JMAIL/249230641

---

Received and deposited to FTLLP Ripco Savings Account in September 2022

## LETTER OF SUPPORT – NICOLET NATIONAL FOUNDATION

On Tuesday, December 20, 2022 at 12:51:44 PM CST, Amy Vanney <[avanney@nicoletbank.com](mailto:avanney@nicoletbank.com)> wrote:

Good Afternoon Tracy:

I wanted to let you know that Friends of Town Line Park has received a donation from our Nicolet National Foundation. This year we are supporting 147 unique organizations. Our goal each year is to allocate 100% of employee donations to non-profit groups across our geographic footprint. Would I be able to stop by tomorrow and drop off your check somewhere?

We would love a picture to share with our employees for our donation. We can of course do the standard photo but we have a contest every year to see which non-profit can do the most creative photo thank you. Last year the Northwoods Children's Museum came up with the attached photo, I am wondering what you can come up with this year 😊

Thank you so much!

***Happy Holidays!***

**Amy B. Vanney**  
Branch Manager

Retail Mortgage Lender  
Rhineland Office

NMLS #1659565  
(715) 362-2651  
[avanney@nicoletbank.com](mailto:avanney@nicoletbank.com)  
[Nicoletbank.com](http://Nicoletbank.com)

This check was received and deposited to Savings on 12/30/2022.