



To visit our website scan QR code



office (954) 969-8605
cell phone (954) 449-3050
email contact@klimekelectricmotor.com

KLIMEK Electric Motor Corp
3420 NW 25th Ave
Pompano Beach, FL 33069
USA

TECH LAB

Submersible pump motor identification

MOTOR FLANGE

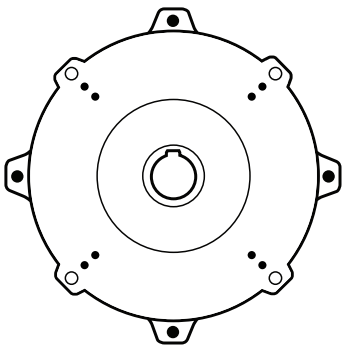

"Z" Flange

Bolt Circle Dimensions:
6.25": 7.125": 8.125"

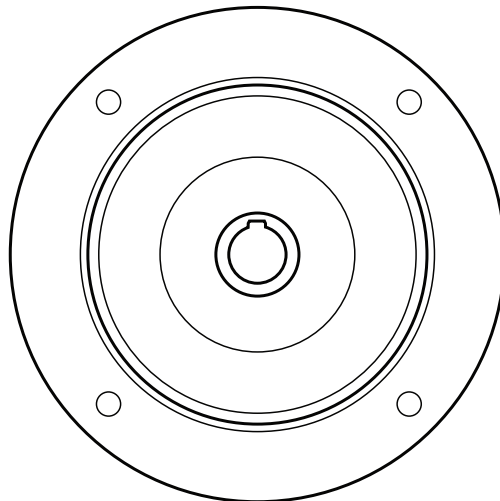

"L32" Flange

Bolt Circle Dimensions:
10.236"

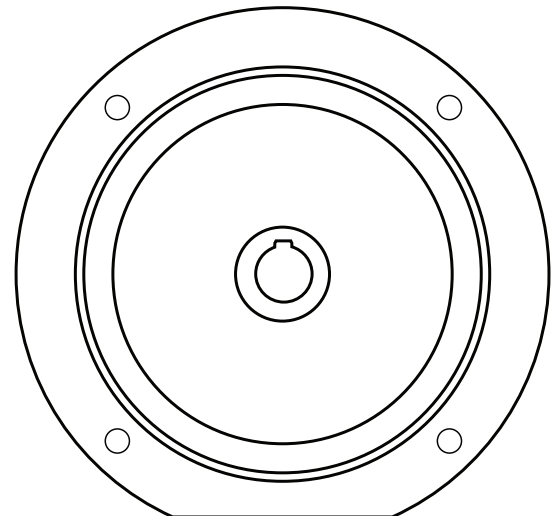

"L38" Flange

Bolt Circle Dimensions:
120.25"

