

Area and Perimeter of Polygons 2

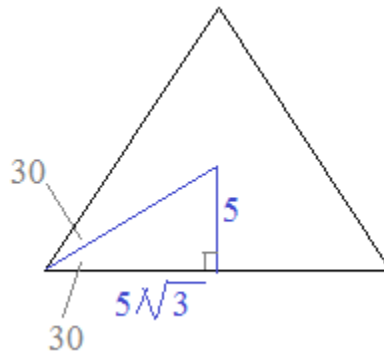

Examples and Practice Exercises (with solutions)

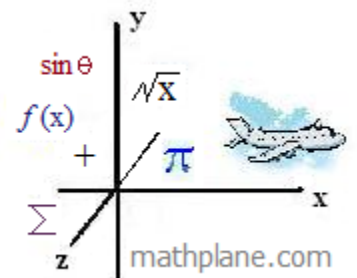

Area and Perimeter of Polygons

Example: Find the area and perimeter of the figure.

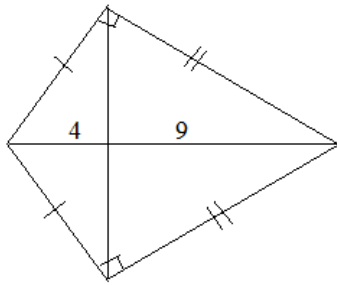

Since the quadrilateral has 2 pairs of adjacent sides that are congruent, it's a kite.

And, the diagonals of a kite are perpendicular.

We can find the geometric mean (altitude to hypotenuse) to find the length of the other diagonal!

$$\frac{4}{x} = \frac{x}{9} \quad x = 6, \text{ so the diagonal is } 12$$

The area of the kite is $\frac{1}{2}$ (diagonal 1)(diagonal 2) =

$$\frac{1}{2} (12)(13) = 78$$

Since the diagonals form 4 right triangle, we can use Pythagorean Theorem to find the sides of the kite...

$$\text{The perimeter is } 10\sqrt{13}$$

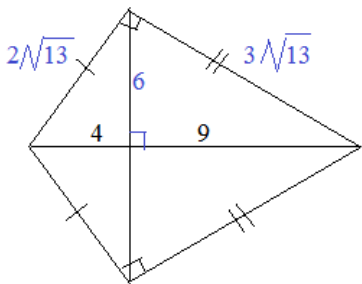

Example: Find the perimeter and area of the rhombus

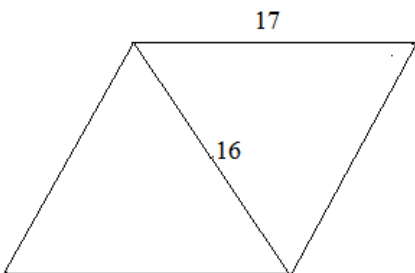

Since all sides of a rhombus are congruent, the perimeter = $4 \times 17 = 68$ units

To find the area, the most direct approach is finding the length of the other diagonal.

***The diagonals of a rhombus are perpendicular bisectors!

Then, recognizing the 8-15-17 Pythagorean Triple.. the other diagonal is 30

$$\text{Area} = \frac{1}{2} d_1 d_2 = \frac{1}{2} (16)(30) = 240 \text{ sq. units}$$

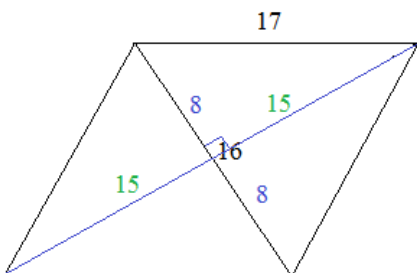

Area and Perimeter of Polygons

Example: What is the area and perimeter of the trapezoid?

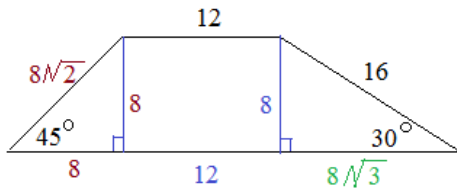
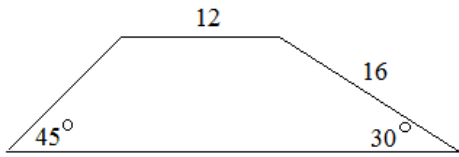

To find the area, we'll need to determine the altitude (height).

Fortunately, the altitudes form special right triangles.

30-60-90 right triangle: hypotenuse is 2x the small leg..

So, the height is 8...

Then, the other leg is $8\sqrt{3}$

And, since the height is 8, the other part of the base is 8... 45-45-90 right triangle...

Perimeter is the sum of all the sides: $48 + 8\sqrt{2} + 8\sqrt{3}$

$$\begin{aligned} \text{Area} &= \frac{1}{2}(\text{base1} + \text{base2})(\text{height}) = \frac{1}{2}(32 + 8\sqrt{3})(8) \\ &= 128 + 32\sqrt{3} \end{aligned}$$

Example: Find the area and perimeter of the triangle.

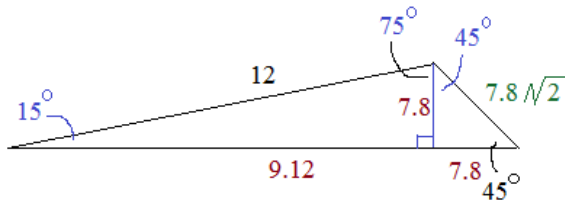
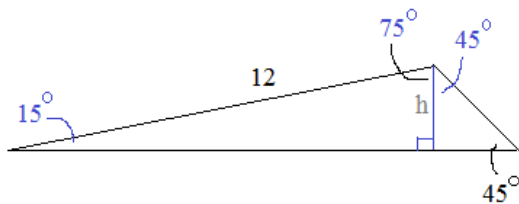
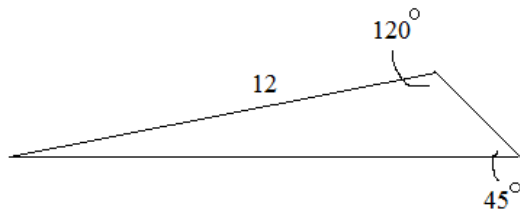

First, we drop an altitude and see that we can use trigonometry and geometry tools to find the other parts...

$$\sin(15^\circ) = \frac{\text{height}}{12} \quad \text{height} = 7.8 \quad (\text{approximately})$$

Since the right part is 45-45-90 right triangle, the right part of the base is 7.8

Then, using the Pythagorean Theorem the left part of the base is 9.12

$$9.12^2 + 7.8^2 = 12^2$$

Perimeter of triangle = $12 + 16.92 + 11.03 = 39.95$ approximately

$$\text{Area} = \frac{1}{2}(16.92)(7.8) = 66 \quad \text{approximately}$$

Example: What is the perimeter and area of a regular pentagon with radius of 7?

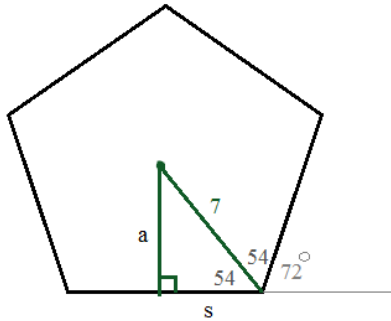

Method 1: $\text{Area} = \frac{1}{2} (\text{apothem})(\text{perimeter})$

From the diagram, $\text{Exterior angle} = \frac{360}{5} = 72^\circ$

Therefore, each interior angle is $180 - 72 = 108^\circ$

$$\sin(54) = \frac{a}{7}$$

$$\text{apothem } a = 7\sin(54) = 5.66$$

$$\cos(54) = \frac{s}{7}$$

$$1/2 \text{ of each side} = s = 7\cos(54) = 4.11$$

$$\text{apothem} = 5.66$$

$$\text{perimeter} = 10 \times 4.11 = 41.1$$

$$\text{Area} = \frac{1}{2} (5.66)(41.1) = 116.3 \text{ (approximately)}$$

Method 2: Find area of triangle then,

$$\text{Area}_{\text{pentagon}} = \left(\frac{1}{2} (\text{base})(\text{height}) \right) \times 10 \text{ triangles}$$

$$\sin(54) = \frac{a}{7}$$

$$a = 7\sin(54) = 5.66$$

$$b = 7\cos(54) = 4.11$$

$$\text{Area of triangle: } \frac{1}{2} (4.11)(5.66) = 11.63$$

$$\text{Area of pentagon: } 10 \times 11.63 = 116.3$$

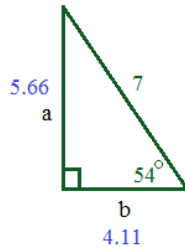

note: to check, use pythagorean theorem:

$$4.11^2 + 5.66^2 = 7^2 \text{ approximately}$$

Example: Find the area of 15 sided regular n-gon with perimeter 180 feet.

To find the area, we want the apothem and perimeter...

The perimeter is given: 180 feet...

$$\text{Area} = \frac{1}{2} (\text{apothem})(\text{perimeter})$$

To find the measure of the apothem, draw a diagram:

Sum of the exterior angles is 360° .
So, each exterior angle measure is $360/15 = 24$ degrees...

therefore, each interior angle is $180 - 24 = 156$ degrees....

And, the radius bisects the angle into 78 degree angles..

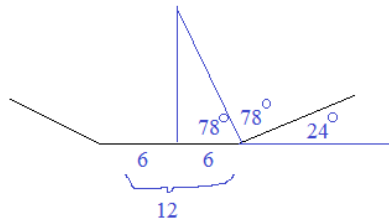

$$\text{Area} = \frac{1}{2} (28.23 \text{ feet})(180 \text{ feet}) = 2540 \text{ square feet}$$

$$\frac{180}{15} = 12 \text{ feet/side}$$

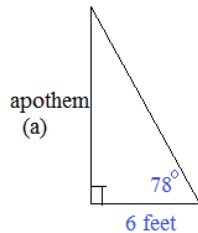

$$\tan(78) = \frac{a}{6}$$

$$\text{apothem } a = 6\tan(78) = 28.23$$

Example: The vertices of triangle ABC are A (-2, 2) B (0, 7) C (6, 8)
Find the area of the triangle.

Method 1: Encasement

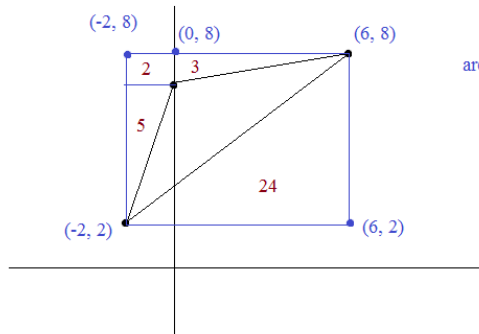
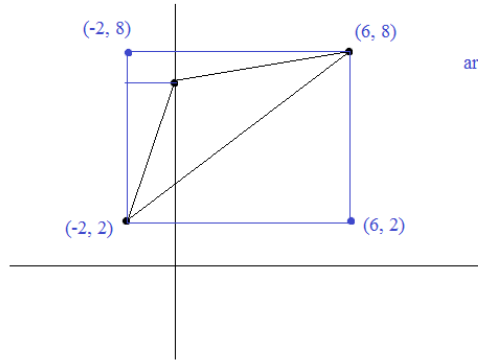
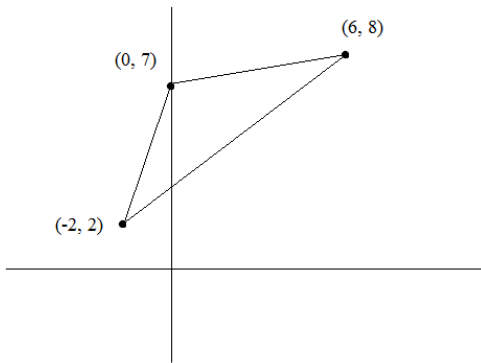

Method 2: Hero's Formula

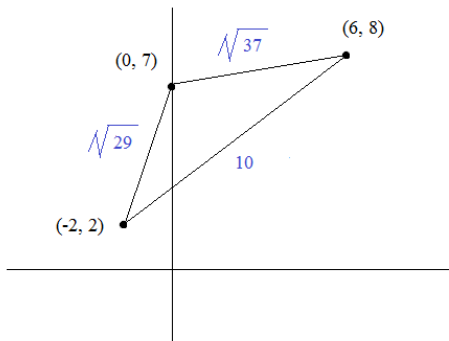

$$\text{semiperimeter} = \frac{\sqrt{37} + \sqrt{29} + 10}{2} = s \text{ approximately } 10.73$$

$$\text{Area} = \sqrt{s(s-a)(s-b)(s-c)} = \sqrt{10.73(4.65)(5.35)(.73)} = 14$$

Method 3: Finding the height...

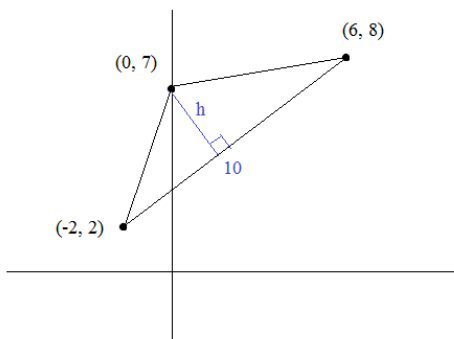

$$h = \text{distance between } (0, 7) \text{ and } \left(\frac{42}{25}, \frac{357}{75}\right)$$

$$\sqrt{2.82 + 5.02} = 2.8$$

$$\text{Area} = \frac{1}{2} (\text{base})(\text{height}) \Rightarrow \frac{1}{2} (10)(2.8) = 14$$

$$\text{Area} = \frac{1}{2} (\text{base})(\text{height})$$

We need to find the height...

$$\text{line segment through } (-2, 2) \text{ and } (6, 8) \quad y - 2 = \frac{3}{4} (x + 2)$$

slope of height is $-4/3$

$$\text{line segment through } (0, 7) \quad y = \frac{-4}{3} x + 7$$

find the intersection using substitution:

$$\frac{-4}{3} x + 7 - 2 = \frac{3}{4} (x + 2)$$

$$\frac{-4}{3} x + 5 = \frac{3}{4} x + \frac{3}{2}$$

$$-16x + 60 = 9x + 18$$

$$42 = 25x$$

$$x = \frac{42}{25}$$

$$y = \frac{-168}{75} + 7$$

$$y = \frac{357}{75}$$

Part I: Answer the following:

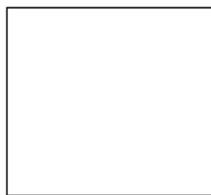

Square; apothem = 5 feet

What is the area?



Square; diagonal = 16cm

What is the area?

What is the length of the apothem?

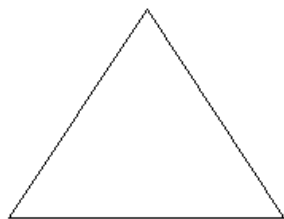

Equilateral triangle; sides = 7 inches

What is the area?

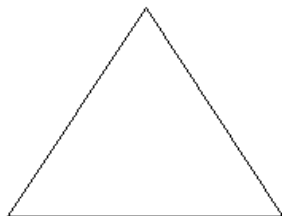

Equilateral triangle; apothem = 5

What is the area?

What is the length of each side?



Rectangle; diagonal = 26
width = 10

What is the perimeter?

What is the area?

Part II: Find the area of each shaded region:

Area of shapes and regular polygons

1) Triangle inside a square:

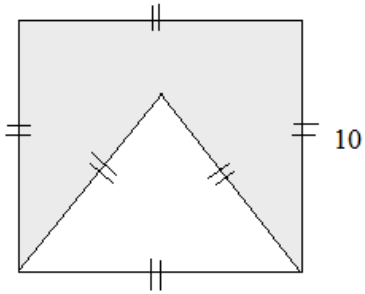

2) A regular hexagon with sides measuring 6 feet:

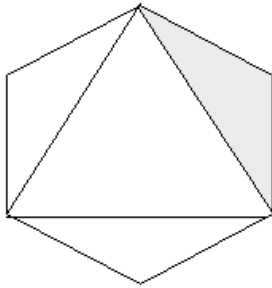

3) Rectangle inscribed in a regular hexagon:

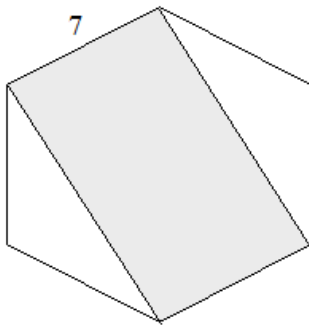

Part III: Find the area of a *regular* hexagon, if

Area of shapes and regular polygons

a) the length of a side is 8

b) the length of an apothem is 8

c) the length of a radius is 8

Part IV:

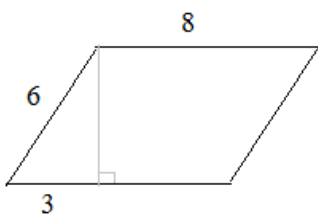

Parallelogram:

What is the perimeter?

What is the area?

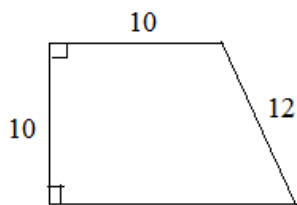

Trapezoid:

What is the perimeter?

What is the area?

Part V:

- 1) Find the angles formed by
 - a) 2 consecutive radii
 - b) the radius and adjoining sidein a regular
 - 1) pentagon
 - a)
 - b)
 - 2) hexagon
 - a)
 - b)
 - 3) octagon
 - a)
 - b)
 - 4) decagon
 - a)
 - b)

- 2) Is this a regular 9 sided polygon?

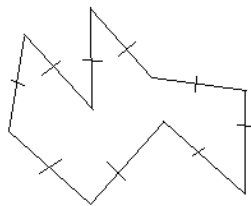

- 3) If the area of the shaded region is 168 square units, what is y ?

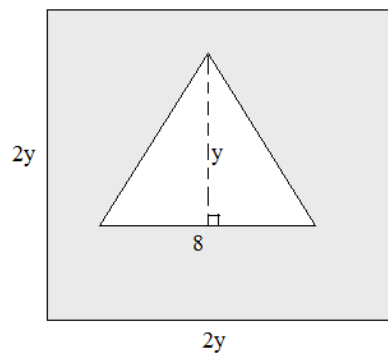

Find the area and perimeter of each figure.

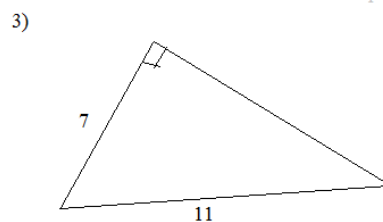
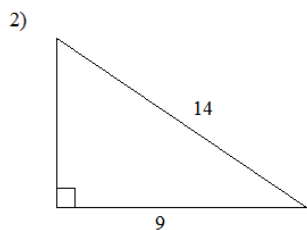
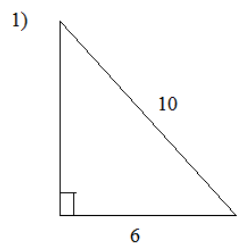

4) (parallelogram)

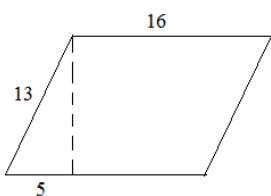

5) (parallelogram)

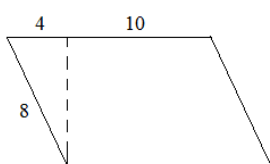

6) (rectangle)

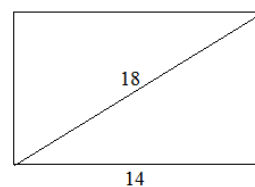

7)

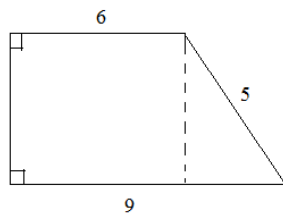

8)

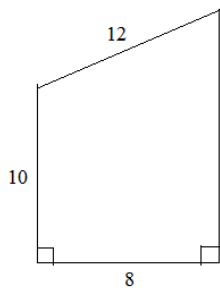

9) (kite)

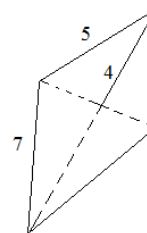

10) (circle)

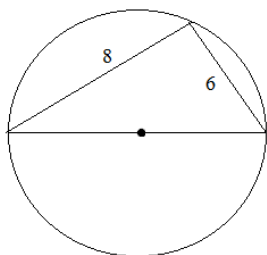

11)

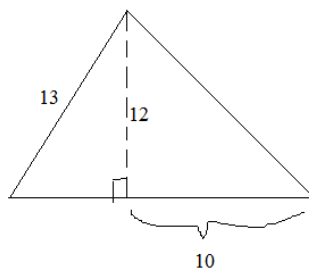

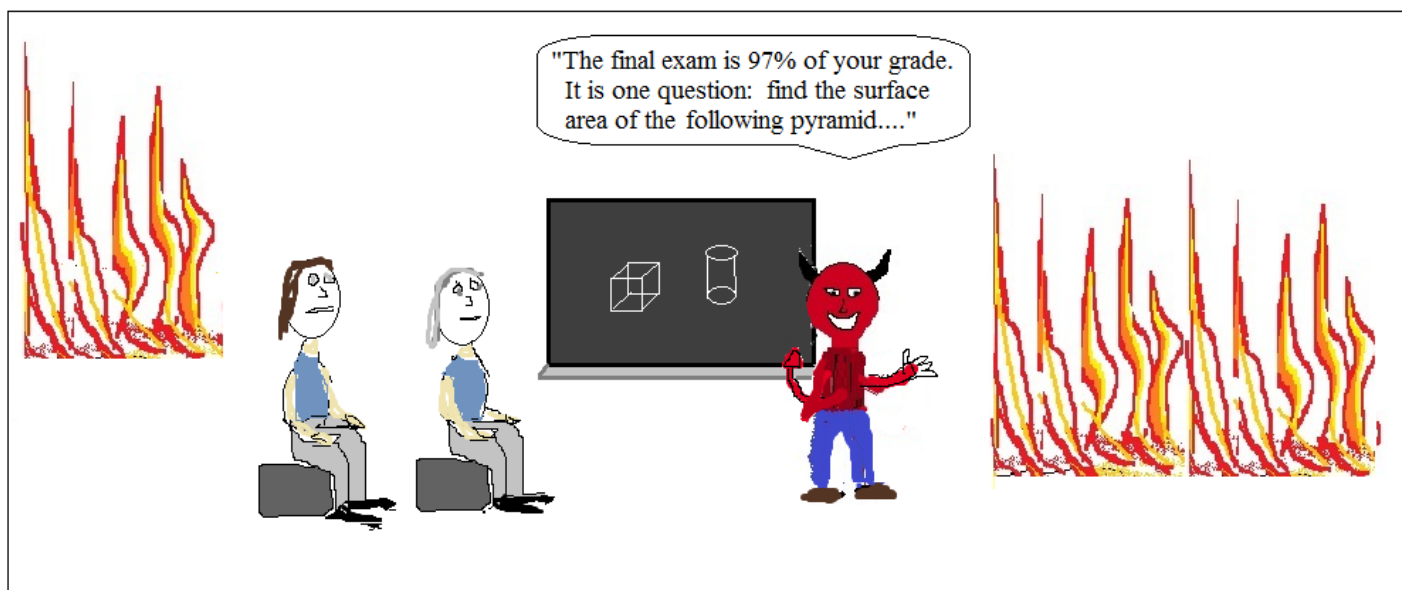

Math in Hell

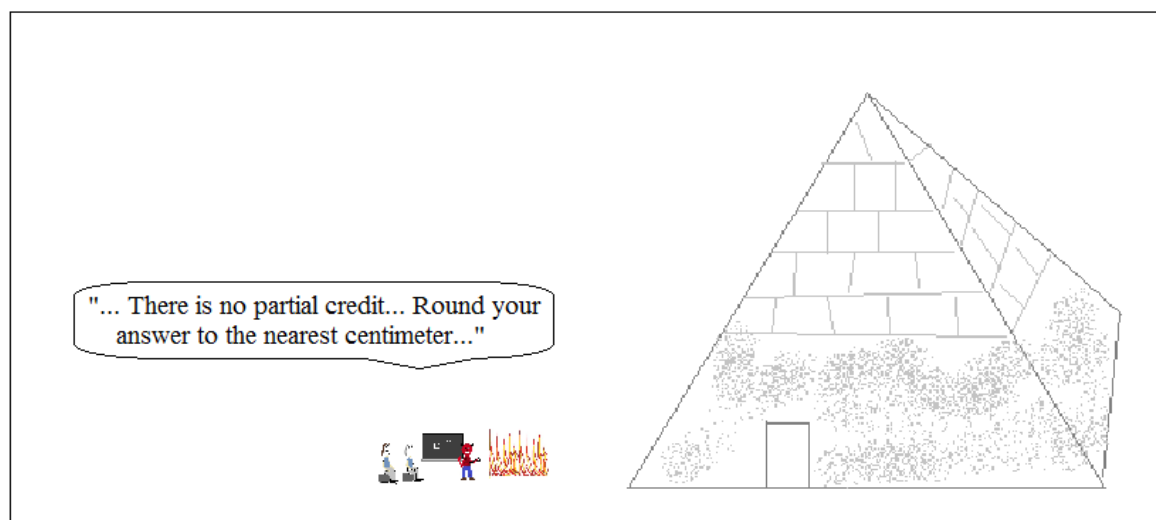

In its 1000 year history, no one ever passed Mr. Devlin's Geometry class.

LanceAF #39 7-1-12
www.mathplane.com

Solutions ->

Part I: Answer the following:

SOLUTIONS

Area of shapes and regular polygons

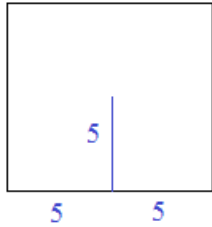

Square; apothem = 5 feet
What is the area?

The apothem connects the center to the midpoint of a side..
(If the apothem is 5', then 1/2 of each side is 5')

$$\text{area} = (\text{side})(\text{side}) = (10\text{ft})(10\text{ft}) = 100 \text{ square feet}$$

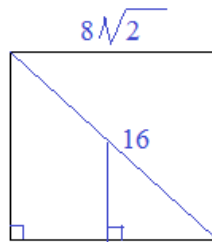

Square; diagonal = 16cm
What is the area?
What is the length of the apothem?

Since the diagonal divides the square into two 45-45-90 triangles, the sides are

$$\frac{16}{\sqrt{2}} = 8\sqrt{2}$$

$$\text{Area} = (\text{side})^2 = 128 \text{ square cm}$$

Then, the apothem is 1/2 of each side:

$$4\sqrt{2} \text{ cm}$$

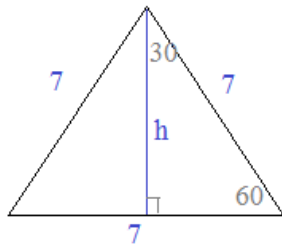

Equilateral triangle; sides = 7 inches

What is the area?

$$\text{area} = \frac{1}{2} (\text{base})(\text{height})$$

Since it is an equilateral \triangle the altitude forms a 30-60-90 right triangle...

$$\text{area} = \frac{1}{2} (7) \left(\frac{7}{2} \sqrt{3} \right) = \frac{49\sqrt{3}}{4} \text{ sq. units}$$

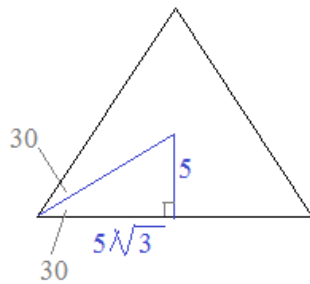

Equilateral triangle; apothem = 5

What is the area? $75\sqrt{3}$

Since it is an equilateral \triangle , the apothem and radius will form a 30-60-90 right \triangle with small side = 5

What is the length of each side?

$$\text{each side is } 10\sqrt{3}$$

the area of the right triangle

$$\text{is } \frac{1}{2} (\text{base})(\text{height}) = \frac{1}{2} \cdot 5\sqrt{3} \cdot 5$$

and, since there are six right triangles inside the entire triangle, the area is $75\sqrt{3}$

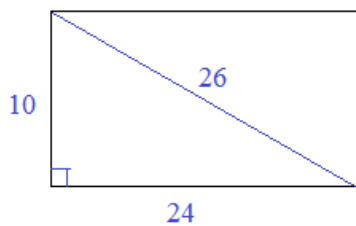

Rectangle; diagonal = 26
width = 10

What is the perimeter? 68

What is the area? 120

The diagonal is the hypotenuse of a right triangle.. Using pythagorean theorem (or recognizing 5-12-13), the length of the rectangle is 24

Part II: Find the area of each shaded region:

SOLUTIONS

Area of shapes and regular polygons

1) Triangle inside a square:

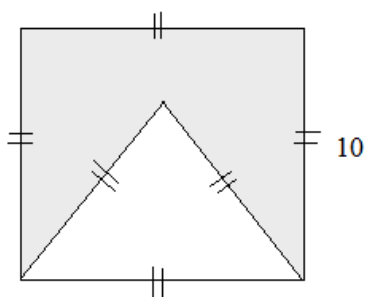

The figure is an equilateral triangle inside a square.

$$\text{Area of square} = s^2 = (10)^2 = 100$$

$$\begin{aligned} \text{Area of triangle} &= \frac{1}{2} (\text{base})(\text{height}) \\ &= \frac{1}{2} (10)(5\sqrt{3}) \\ &= 25\sqrt{3} \end{aligned}$$

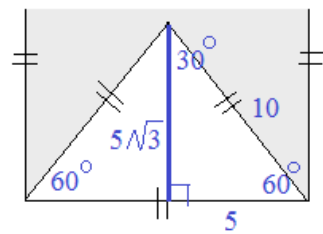

30-60-90 right \triangle

$$\text{shaded area} = A_S - A_T$$

$$= 100 - 25\sqrt{3}$$

2) A regular hexagon with sides measuring 6 feet:

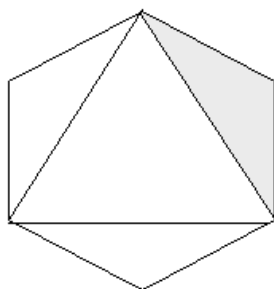

Each interior angle measures 120 degrees:

$$\frac{(6 - 2) \cdot 180}{6} = 120$$

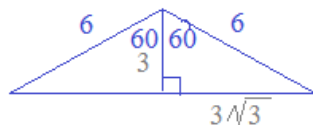

Base of the triangle = $6\sqrt{3}$

Height of the triangle = 3

$$\text{Area} = \frac{1}{2}bh = 9\sqrt{3} \text{ square feet}$$

3) Rectangle inscribed in a regular hexagon:

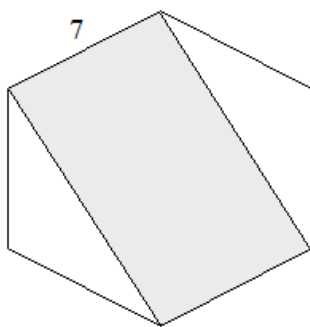

Area of rectangle = length x width...
So, we need to find the length:

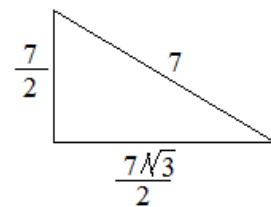
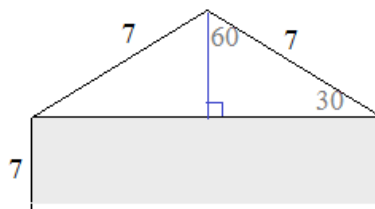

So, the length of the entire triangle base (i.e. the length of the rectangle) = $7\sqrt{3}$

$$\text{Area rectangle} = 7 \times 7\sqrt{3} = 49\sqrt{3}$$

Part III: Find the area of a *regular* hexagon, if

SOLUTIONS

Area of shapes and regular polygons

a) the length of a side is 8

Each interior angle of a regular hexagon is 120 degrees...
So, there are 6 equilateral triangles inside the hexagon...

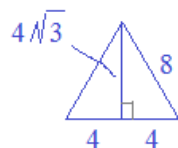
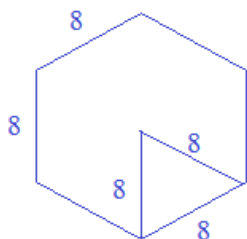

Area of equilateral triangle = $16\sqrt{3}$

therefore, the area of the hexagon is

$$6 \times (\text{area of triangle}) = \boxed{96\sqrt{3}} \quad \boxed{166.3}$$

b) the length of an apothem is 8

Again, we have a 30-60-90 triangle..
The big length is 8... So, the small length is

$$\frac{8}{\sqrt{3}}$$

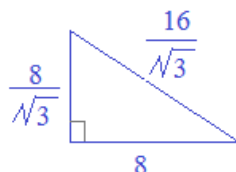
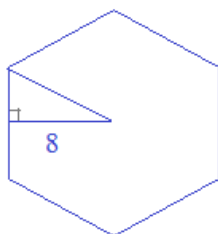

The area of this right triangle is

$$\frac{1}{2} (8) \left(\frac{8}{\sqrt{3}} \right) = \frac{32}{\sqrt{3}}$$

therefore, the area of the hexagon is

$$12 \times (\text{area of triangle}) = \boxed{\frac{384}{\sqrt{3}}} \quad \boxed{221.7}$$

c) the length of a radius is 8

Since this is a (regular) hexagon,
the length of a radius is the same
as the length of a side...

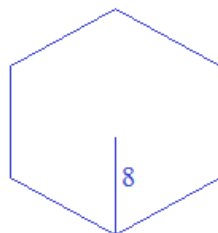

Therefore, the area is the same
as the hexagon in a)

$$\boxed{96\sqrt{3}}$$

Part IV:

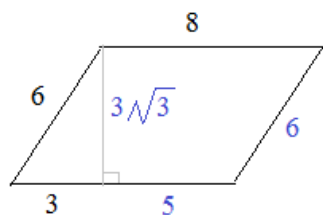

Parallelogram:

What is the perimeter?

opposite sides of parallelogram are congruent,
so perimeter = $6 + 8 + 6 + 8 = \boxed{28}$

What is the area?

$$\text{area} = (\text{base})(\text{height}) = (8)(3\sqrt{3})$$

$$\boxed{24\sqrt{3}}$$

since the right triangle has hypotenuse 6 and base 3, it must be a 30-60-90 right triangle..
(the hypotenuse is 2x the length).. Therefore,
the height of the parallelogram is $3\sqrt{3}$

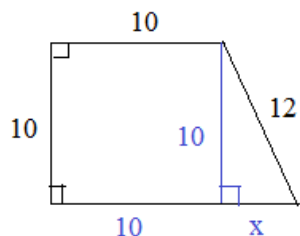

Trapezoid:

What is the perimeter?

$$10 + 10 + 10 + 12 + 2\sqrt{11} =$$

Pythagorean Theorem:

$$(10)^2 + (x)^2 = (12)^2$$

$$x = \sqrt{44} = 2\sqrt{11}$$

What is the area?

$$\boxed{42 + 2\sqrt{11}}$$

$$\text{Area} = \frac{1}{2} (\text{base1} + \text{base2})(\text{height})$$

$$= \frac{1}{2} (20 + 2\sqrt{11})(10) = \boxed{100 + 10\sqrt{11}}$$

Part V:

Area of shapes and regular polygons

SOLUTIONS

- 1) Find the angles formed by
- a) 2 consecutive radii
 - b) the radius and adjoining side
- in a regular
- 1) pentagon
 - a) 72°
 - b) 54°
 - 2) hexagon
 - a) 60°
 - b) 60°
 - 3) octagon
 - a) 45°
 - b) 62.5°
 - 4) decagon
 - a) 36°
 - b) 72°

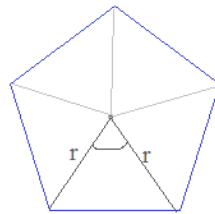

$$360 \div 5 = 72^\circ$$

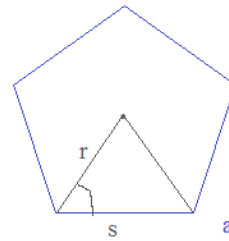

Since the 5 triangles are isosceles...
 $\text{angle} + \text{angle} + 72 = 180$
 $\text{angle} = 54^\circ$

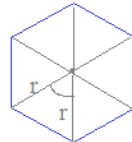

$$360 \div 6 = 60^\circ$$

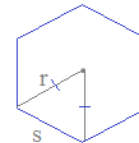

Since the radii angle is 60, the other two angles add up to 180..

Therefore, the other angles are 60 and 60..

An octagon has 8 congruent radii angles...

$$360 \div 8 = 45^\circ$$

Since the radii angle is 45 degrees.. the 2 base angles must add up to 135 degrees...

$$62.5 \text{ and } 62.5$$

Decagon has 10 sides.. 10 congruent radii angles.. 36 degrees

The radius/side angles are 72 degrees...

- 2) Is this a regular 9 sided polygon?

No, it is not...

It is 'equilateral'...

but, it is not 'equiangular'...

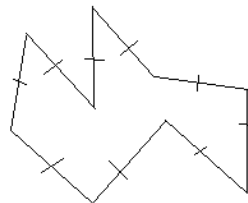

- 3) If the area of the shaded region is 168 square units, what is y?

$$(2y)^2 - \frac{1}{2}(8)(y) = 168$$

$$4y^2 - 4y = 168$$

$$4(y^2 - y - 42) = 0$$

$$4(y + 6)(y - 7) = 0$$

$y = -6$ or 7 ... (but, it cannot be negative...)

$$y = 7$$

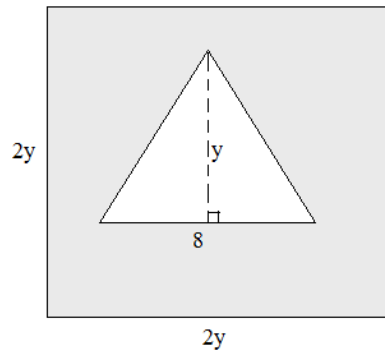

Check:

Area of square: $14 \times 14 = 196$

Area of triangle: $\frac{1}{2}(8)(7) = 28$

Shaded area = $196 - 28 = 168$ ✓

Find the area and perimeter of each figure.

mathplane.com

SOLUTIONS

Pythagorean Theorem

1) $10^2 - 6^2 = b^2 \quad b = 8$

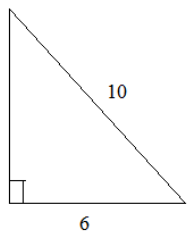

area = $\frac{1}{2}(\text{base})(\text{height})$
 $= \frac{1}{2}(6)(8)$
 $= 24$

perimeter: 24

2) $14^2 - 9^2 = b^2 \quad b = \sqrt{115}$

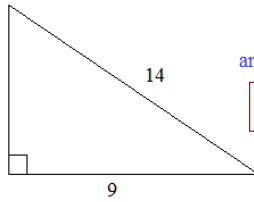

area = $\frac{9}{2}\sqrt{115}$
 approx 48.26

perimeter: $23 + \sqrt{115}$

3) area = $21\sqrt{2}$

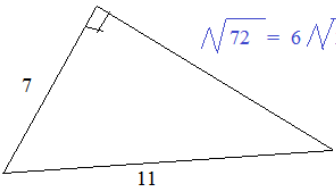

$\sqrt{72} = 6\sqrt{2}$

perimeter: $18 + 6\sqrt{2}$

4) (parallelogram)

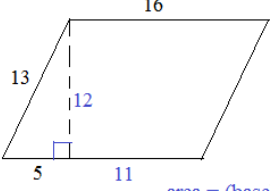

area = (base)(height)
 $= (16)(12) = 192$

perimeter: 58

5) (parallelogram)

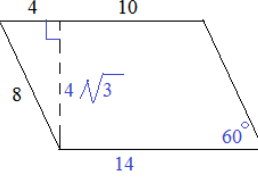

area = $56\sqrt{3}$

perimeter: 44

6) (rectangle)

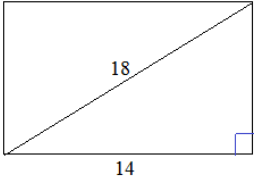

area = $112\sqrt{2}$

perimeter = $28 + 16\sqrt{2}$

7)

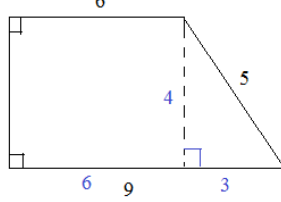

perimeter: 24

area = $\frac{1}{2}(\text{base}_1 + \text{base}_2)(\text{height})$
 $= \frac{1}{2}(9 + 6)(4) = 30$

8)

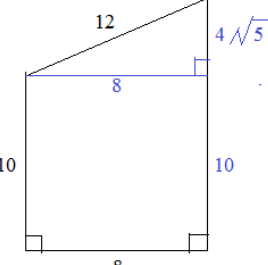

area = $80 + 16\sqrt{5}$

perimeter = $40 + 4\sqrt{5}$

9) (kite)

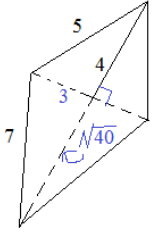

perimeter = 24

area = $\frac{1}{2}(\text{diagonal } 1)(\text{diagonal } 2)$
 $= \frac{1}{2}(6)(4 + 2\sqrt{10}) \approx 40.97$

10) (circle)

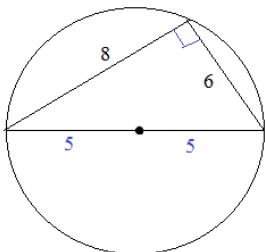

Note: triangle inscribed in semicircle is right triangle..

perimeter/circumference: 10π

area = 25π

11)

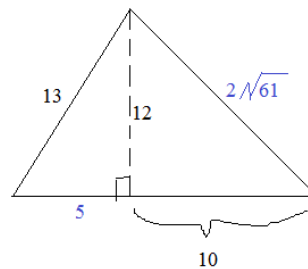

area = $(1/2)(10)(12) = 60$

perimeter = $28 + 2\sqrt{61}$

Pythagorean Theorem: $a^2 + b^2 = c^2$

rectangle: area = (length)(width)
 perimeter = 2(length) + 2(width)

triangle: area = (1/2)(base)(height)
 perimeter = (side) + (side) + (side)

circle: area = $\pi(\text{radius})^2$

circumference = $2\pi(\text{radius})$

kite: area = (1/2)(diagonal 1)(diagonal 2)
 (or, find area of each triangle)

trapezoid: area = (1/2)(base 1 + base 2)(height)

Thanks for visiting. (Hope it helped!)

Find more geometry content at mathplane.com

Enjoy

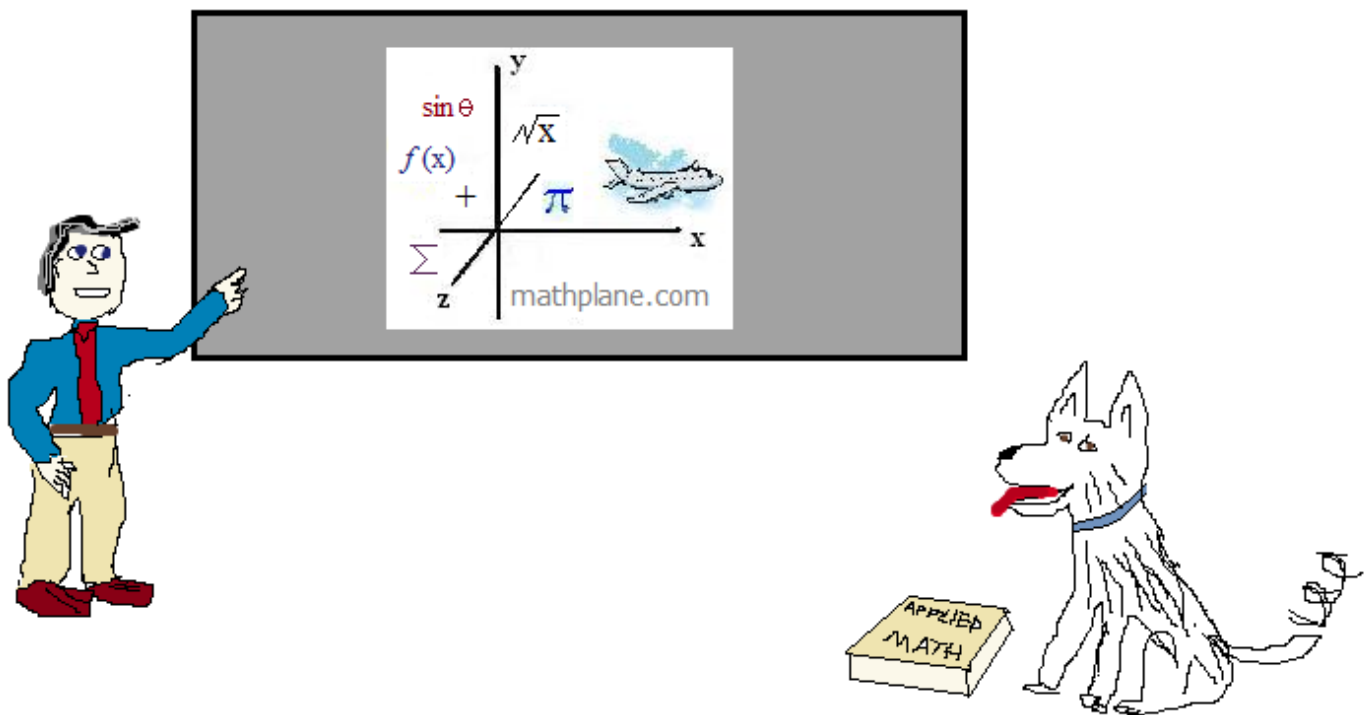

Also, at our store on [TeachersPayTeachers](https://www.teacherspayteachers.com)

And, Mathplane *Express* for mobile at Mathplane.ORG