

NOTES:

- ALL RAIL AND POST TO BE CAN/CSA G40.21 GRADE 350W OR ASTM A500 GRADE C. MISCELLANEOUS PLATE TO BE CAN/CSA G40.21 GRADE 300W.
- ALL ROUGH EDGES SHALL BE GROUND SMOOTH AND WELD SPLATTER SHALL BE REMOVED.
- WELDED FENCE SHALL BE GALVANIZED AFTER FABRICATION IN ACCORDANCE WITH ASTM A123/A123M.
- FIELD WELDING SHALL BE KEPT TO A MINIMUM. DAMAGED GALVANIZING SHALL BE REPAIRED IN ACCORDANCE WITH SS 741.39.
- VENT AND DRAIN HOLES:
 - RAILS SHALL BE PROVIDED WITH BOTTOM DRAIN/VENT HOLE AT BOTH ENDS BETWEEN POSTS.
 - WHERE A POST IS EMBEDDED IN CONCRETE WITH A SLOPED TOP SURFACE OR WHERE IT IS SUPPORTED ON A SLOPED BASE PLATE, THE DRAIN/VENT HOLE NEAR THE BOTTOM OF THE POST SHALL BE LOCATED ON THE LOWER SIDE OF THE SLOPE.
- POST ANCHORS SHALL BE ASTM A307 THREADED ROD, GALVANIZED TO THE REQUIREMENTS OF ASTM A153/A153M.
- ACCEPTABLE ADHESIVES FOR BONDING THE ANCHORS INTO CONCRETE INCLUDE:
 - HILTI HIT HY-200
 - REDHEAD EPCON C6+
 - UCAN FLO-ROX FR6-SD
 - POWERS PE1000+
- ANCHORS SHALL BE INSTALLED IN ACCORDANCE WITH THE ADHESIVE MANUFACTURER'S INSTRUCTIONS.
- Holes in concrete for anchors must be drilled with hammer drill and a carbide tipped bit. Concrete in holes must be water-saturated or dry when installing anchors.
- ALTERNATIVE ANCHOR INSTALLATIONS THAT DO NOT MEET THE DETAILS ON THIS DRAWINGS WILL REQUIRE AN ENGINEERED DESIGN DEMONSTRATING THAT THE ALTERNATIVE BUILDING CODE OF CANADA LOADING REQUIREMENTS ON "GUARDS" AND ON "HANDRAILS" SHALL BE CONSIDERED IN DETERMINING POST ANCHOR LOADING.

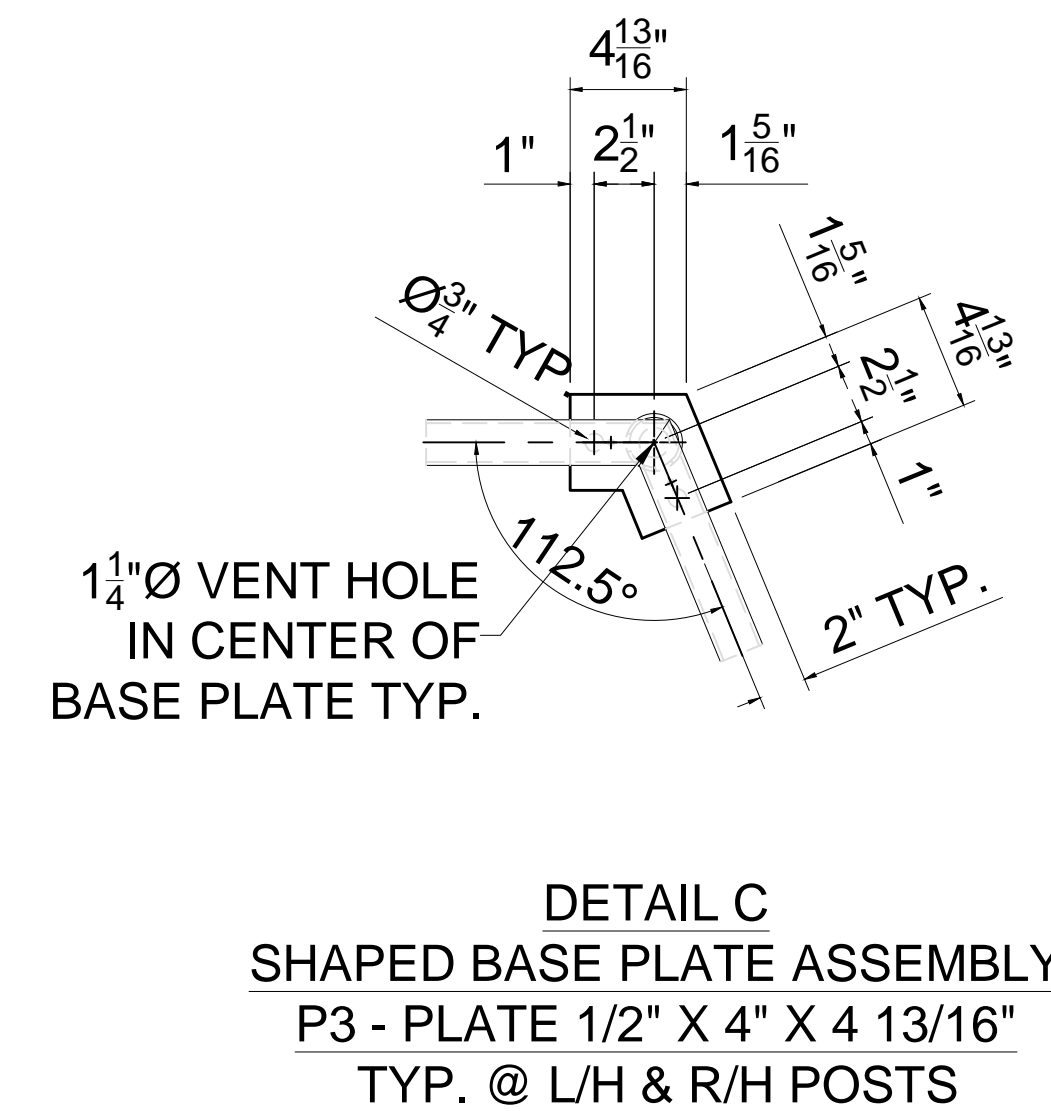
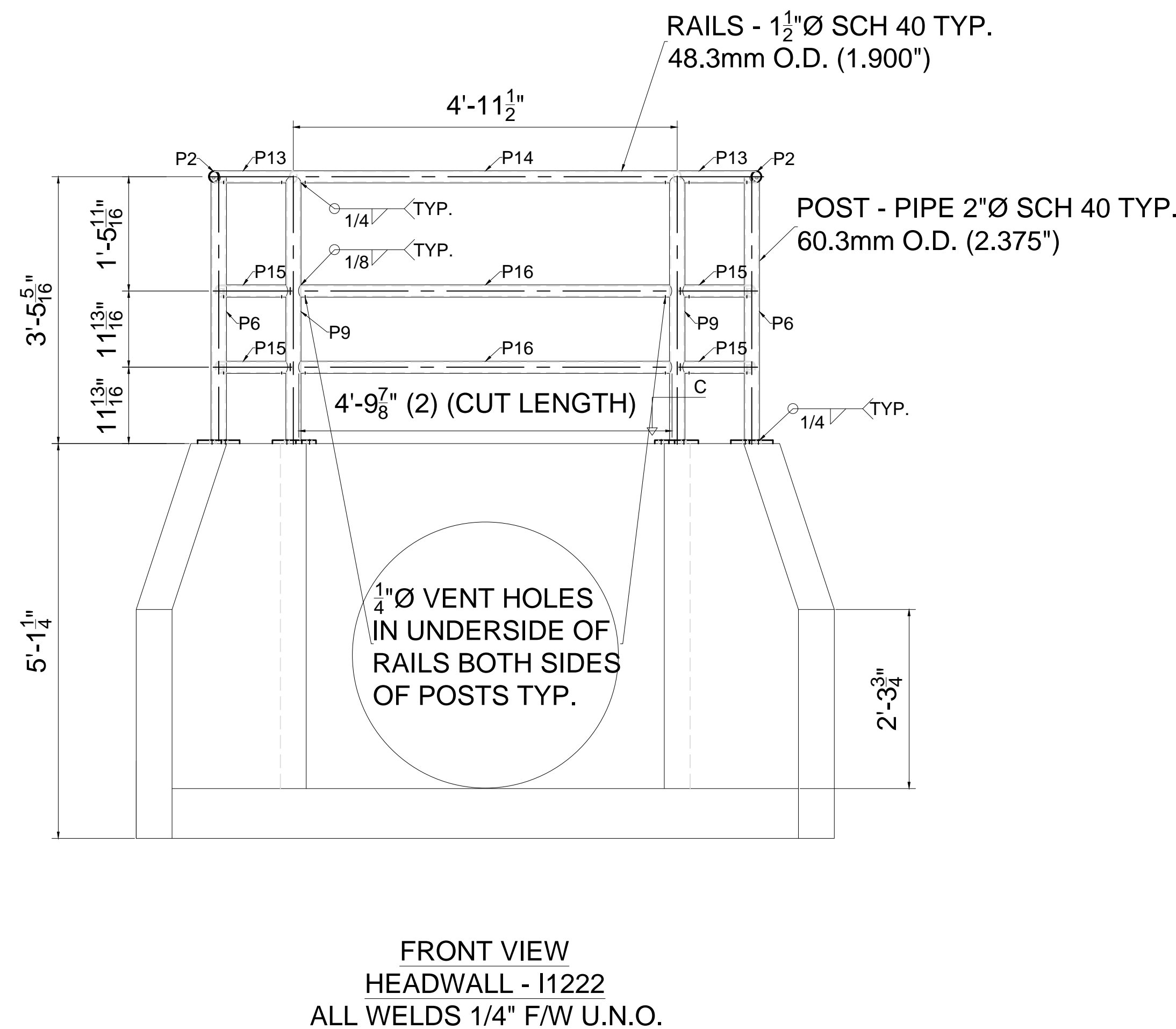
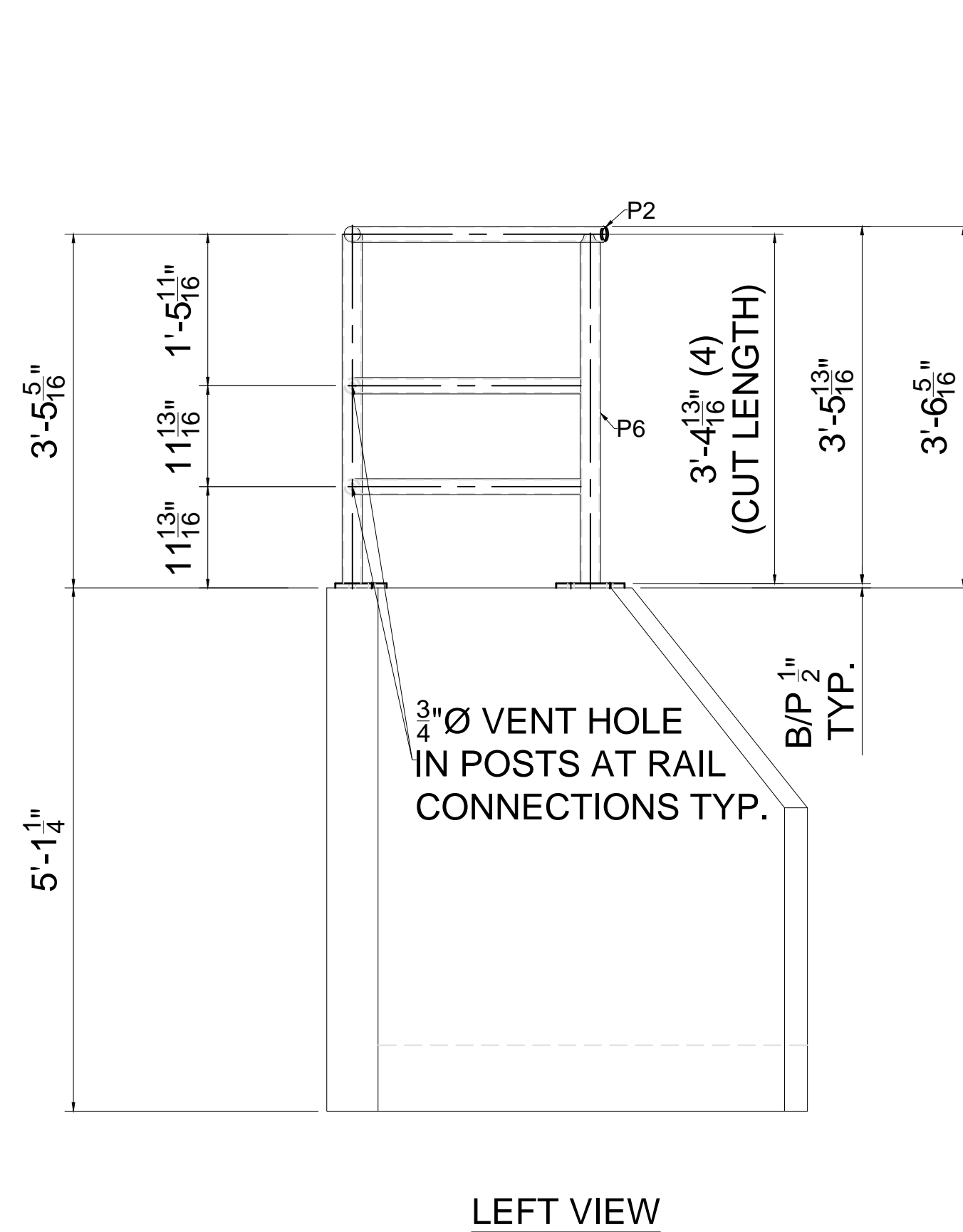

Leko PRECAST LTD.				I1222 Pedestrian Fence	
DRAWN BY: JJP	CHECKED BY:	APPROVED BY:	DATE:	March 21st, 2025	
ASSEMBLY ENG:	PREVIOUS ENG:	DRAWING NO:	11151	REVISION:	1
SCALE: 3/4"=1'-0" ISOMETRIC. DO NOT SCALE THIS DRAWING					
lekoprecast.com 250-549-3010 9538 HWY 97 VERNON B.C. V1H 1T5					