

BOX CULVERT PLAN VIEW

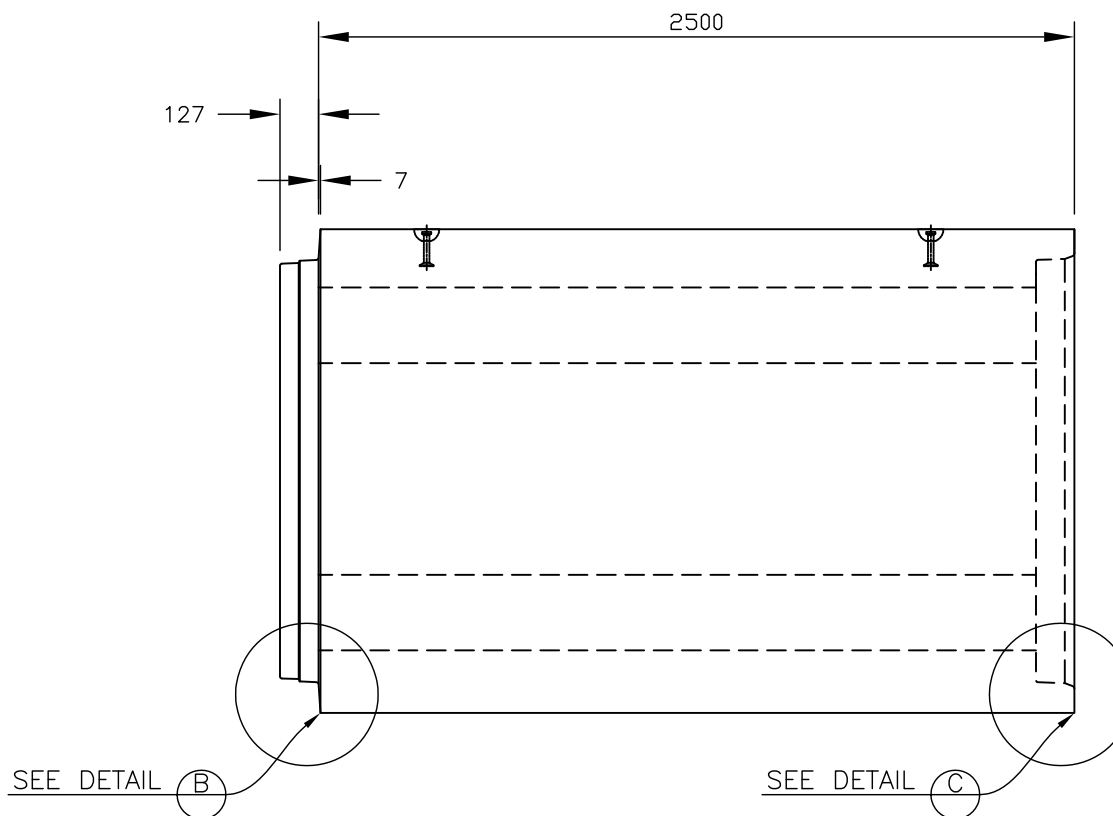

BOX SIDE ELEVATION SECTION-VIEW

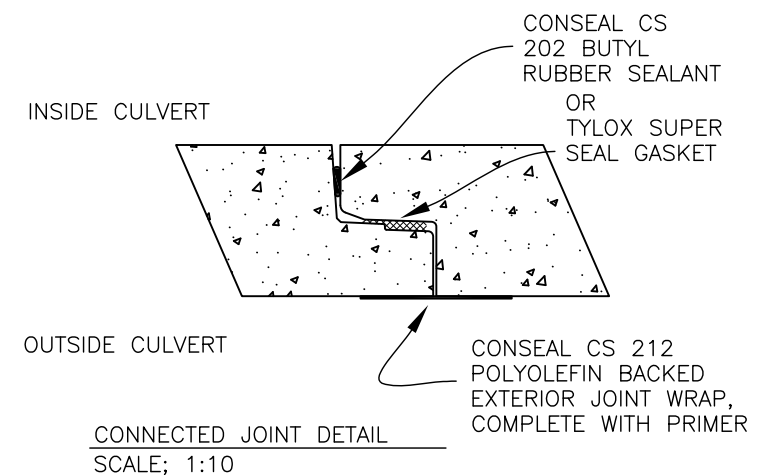
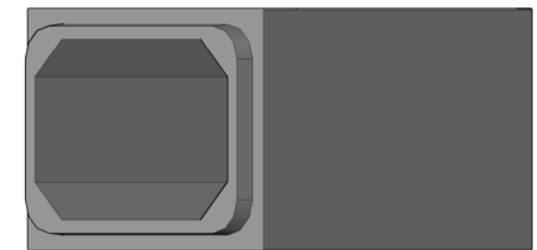

-1.5 M MAX. BACKFILL HEIGHT FROM T.O. BOX CULVERT
 -0.6 M MIN. BACKFILL HEIGHT FROM T.O. BOX CULVERT
 -REF. BOURCET DRAWING 51.1, REV. 5, ISSUED NOV. 8 2013

GENERAL NOTES

Precast concrete shall be exposure Class HSe and meet min compressive strength of 35MPa @28d

Air Category: 4.0% - 7.0%
 Aggregate: CSA/CAN A23.4
 Maximum Size: 20mm
 Admixtures: CSA/CAN A23.4
 Reinforcing: Grade 400W CSA G30.18
 Inserts/Embeds: As noted in drawing details

Manufacture of precast concrete units shall be in accordance with specification CSA A23.4, ASTM C1433M

Designed to HS20, BCL 625 live loadings

** LEKO PRECAST LTD SHALL NOT BE RESPONSIBLE FOR ANY INSTALLATION PRACTICES FOLLOWED ON-SITE UNLESS PERFORMED BY LEKO PRECAST LTD **

BOX CULVERT 1812 WEIGHT: 8,900 KG. (19,500 LBS.)
 BOX CULVERT 1812 VOLUME: 2.1m³/m (460 igal/m)

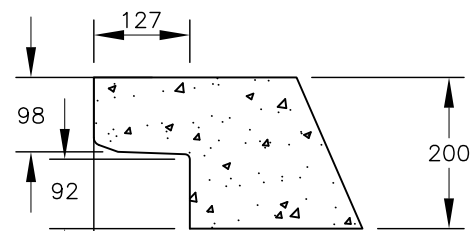

SOCKET DETAIL (C)
SCALE: 1:10

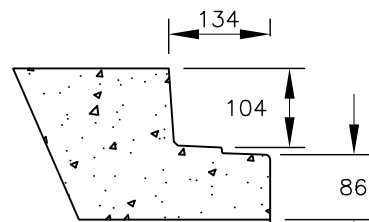

SPIGOT DETAIL (B)
SCALE: 1:10



BOX CULVERT; 1.8m x 1.2m, 2.50m LG.

DRAWN BY: JA	CHECKED BY:	APPROVED BY:	DATE: Sept 2020
ASSEMBLY DWG.	PREVIOUS DWG.	DRAWING NO. BX 1812	REVISION 0
SCALE: 1:25 ISOMETRIC: 1:50		DO NOT SCALE THIS DRAWING	