

BOX CULVERT PLAN VIEW

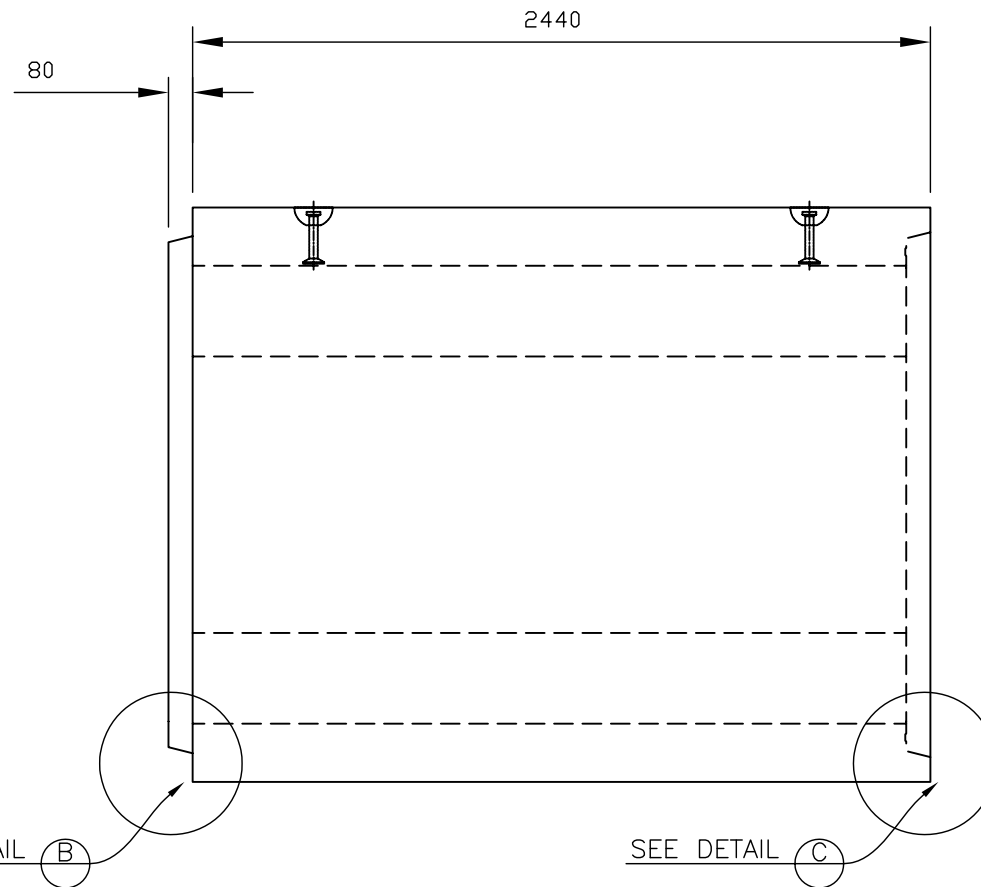

BOX SIDE ELEVATION SECTION-VIEW

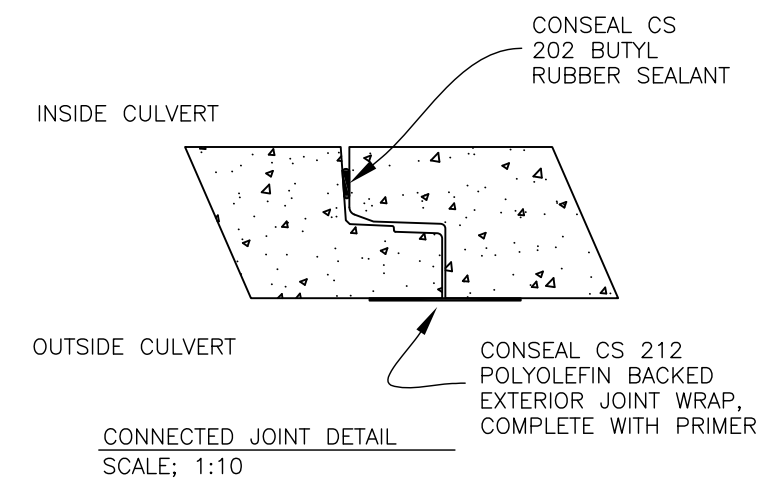
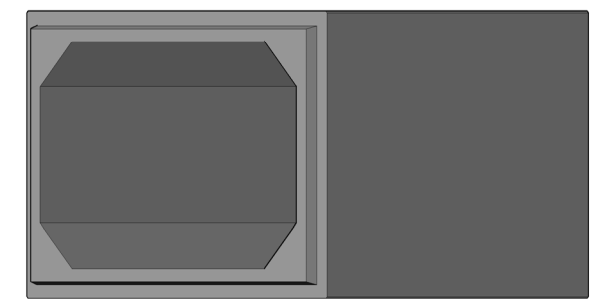

-1.5 M MAX. BACKFILL HEIGHT FROM T.O. BOX CULVERT
 -0.6 M MIN. BACKFILL HEIGHT FROM T.O. BOX CULVERT
 -REF. BOURCET DRAWING 51.1, REV. 5, ISSUED NOV. 8 2013

GENERAL NOTES
 Precast concrete shall be exposure Class HSe and meet min compressive strength of 35MPa @28d
 Air Category: 4.0% - 7.0%
 Aggregate: CSA/CAN A23.4
 Maximum Size: 20mm
 Admixtures: CSA/CAN A23.4
 Reinforcing: Grade 400W CSA G30.18
 Inserts/Embeds: As noted in drawing details
 Manufacture of precast concrete units shall be in accordance with specification CSA A23.4, ASTM C1433M
 Designed to HS20, BCL 625 live loadings
 ** LEKO PRECAST LTD SHALL NOT BE RESPONSIBLE FOR ANY INSTALLATION PRACTICES FOLLOWED ON-SITE UNLESS PERFORMED BY LEKO PRECAST LTD **

BOX CULVERT 2415 WEIGHT: 11,100 KG. (24,500 LBS.)
 BOX CULVERT 2415 VOLUME: 3.4m³/m (750 igal/m)

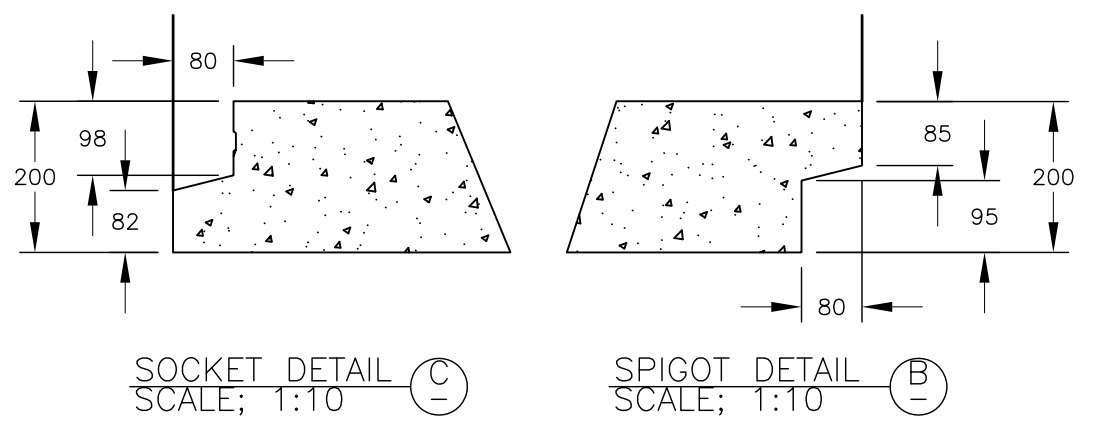

SOCKET DETAIL C
 SCALE: 1:10

SPIGOT DETAIL B
 SCALE: 1:10

				BOX CULVERT; 2.4m x 1.5m, 2.40m LG.			
				DRAWN BY: JA	CHECKED BY:	APPROVED BY:	DATE: Sept 2020
ASSEMBLY DWG.		PREVIOUS DWG.		DRAWING NO.		REVISION	
SCALE: 1:25		ISOMETRIC: 1:50		BX 2415		4	
DO NOT SCALE THIS DRAWING							
lekoprecast.com 250-549-3010 9538 HWY 97 VERNON B.C. V1H 1T5							