

LANE INTERNATIONAL
POLYPROPYLENE 13" (330)
LADDER RUNGS

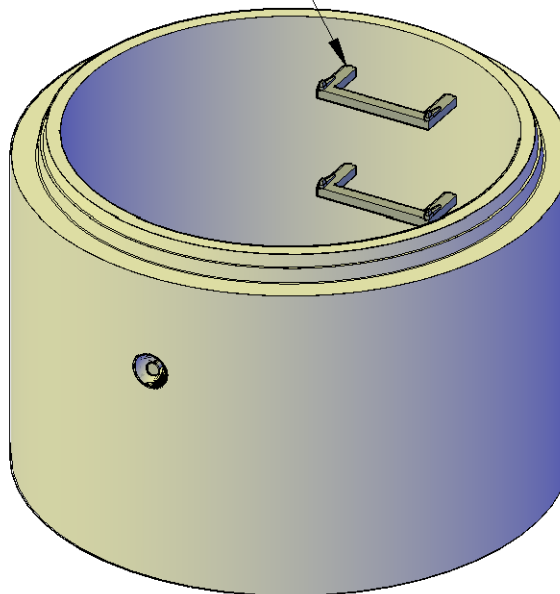

GENERAL NOTES

Manufacture of precast manhole barrels shall be in accordance with CSA A23.1/A257 and ASTM C478 specifications

Concrete shall be exposure Class HSe and meet min compressive strength of 30MPA @ 28d

Air Category: 4.0% - 7.0% (except where zero-slump concrete is used)

Aggregate: CSA/CAN A23.4
Maximum Size: 20mm

Admixtures: CSA/CAN A23.4
Reinforcing: Grade 400W CSA G30.18

Inserts/Embeds: As noted in drawing details

Lifting Apparatus: 2x 4T Starcon anchors

*** LEKO PRECAST LTD SHALL NOT BE RESPONSIBLE FOR ANY INSTALLATION PRACTICES FOLLOWED ON-SITE UNLESS PERFORMED BY LEKO PRECAST LTD **

Meets H-20 Loading

1733Kg (3812 LBS)



48" x 3ft (1220mm x 915mm) MANHOLE BARREL

DRAWN BY: JP	CHECKED BY:	APPROVED BY:	DATE: MAY 2024
ASSEMBLY DWG.	PREVIOUS DWG.	DRAWING NO. M4803B	REVISION 0
SCALE: 1:20	ISOMETRIC: 1:20		
DO NOT SCALE THIS DRAWING			