

LANE INTERNATIONAL
POLYPROPYLENE 13"(330)
LADDER RUNGS

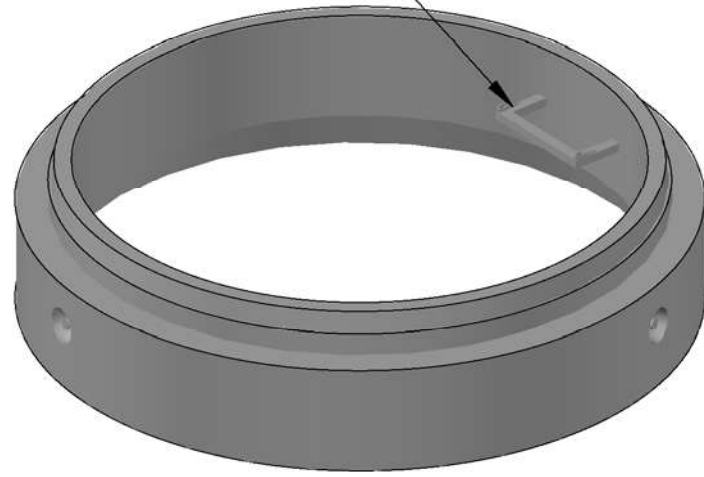

GENERAL NOTES

Precast manhole units shall be manufactured in accordance with CSA A257 and ASTM C478

Precast concrete shall be exposure Class HSe and meet min compressive strength of 30MPa @28d

Air Category: 4.0% – 7.0% (except where zero-slump concrete is used)

Aggregate: CSA/CAN A23.4 Maximum Size: 20mm

Admixtures: CSA/CAN A23.4

Reinforcing: Grade 400W CSA G30.18, 3x12 W2.5/W2.5

Inserts/Embeds: As noted in drawing details

Manufacture of precast concrete units shall be in accordance with specification CSA A23.4

**** LEKO PRECAST LTD SHALL NOT BE RESPONSIBLE FOR ANY INSTALLATION PRACTICES FOLLOWED ON-SITE UNLESS PERFORMED BY LEKO PRECAST LTD ****

Meets H-20 loading

Requires 3-4t Starcon clutches

600Kg (1,320 LBS)



60" x 1ft (1525mm x 305mm) MANHOLE BARREL

DRAWN BY: JA	CHECKED BY:	APPROVED BY:	DATE: JANUARY 2023
ASSEMBLY DWG.	PREVIOUS DWG.	DRAWING NO. M6001	REVISION 6
SCALE: 1:20	ISOMETRIC: 1:20		
DO NOT SCALE THIS DRAWING			