

LANE INTERNATIONAL  
 POLYPROPYLENE 13"(330)  
 LADDER RUNGS

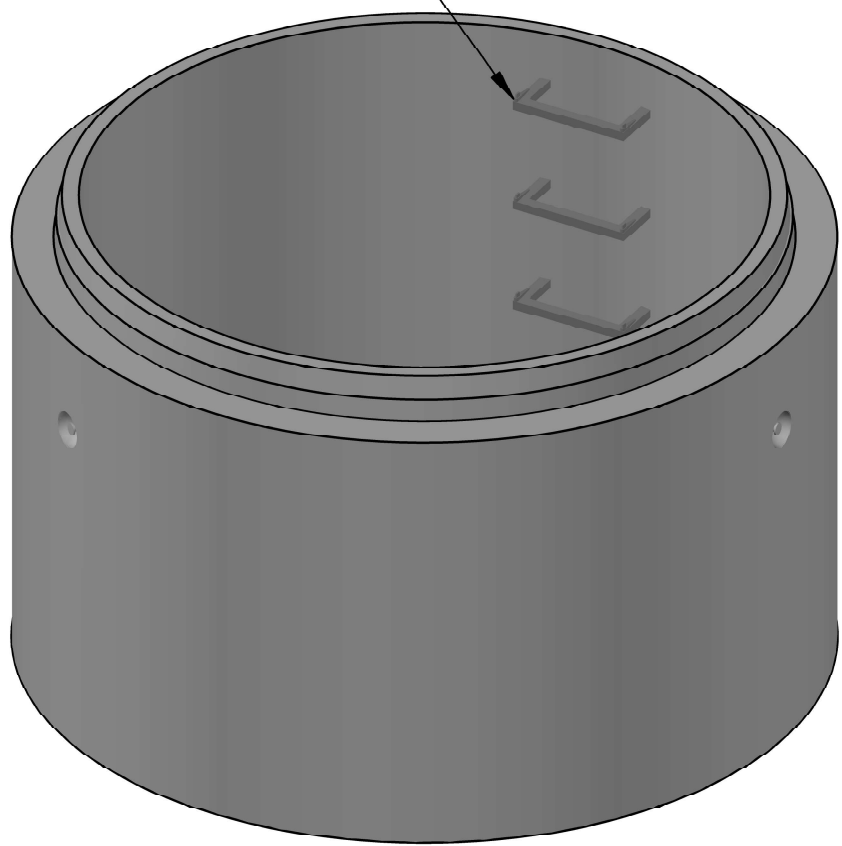

**GENERAL NOTES**

Precast manhole units shall be manufactured in accordance with CSA A257 and ASTM C478

Precast concrete shall be exposure Class HSe and meet min compressive strength of 30MPa @28d

Air Category: 4.0% - 7.0% (except where zero-slump concrete is used)

Aggregate: CSA/CAN A23.4 Maximum Size: 20mm

Admixtures: CSA/CAN A23.4

Reinforcing: Grade 400W CSA G30.18, 3x12 W2.5/W2.5

Inserts/Embeds: As noted in drawing details

Manufacture of precast concrete units shall be in accordance with specification CSA A23.4

**\*\* LEKO PRECAST LTD SHALL NOT BE RESPONSIBLE FOR ANY INSTALLATION PRACTICES FOLLOWED ON-SITE UNLESS PERFORMED BY LEKO PRECAST LTD \*\***

(3) 4t STARCON ANCHORS  
 3,300Kg (7,300 LBS)



72" x 4ft (1820mm x 1220mm) MANHOLE BARREL			
DRAWN BY: JA	CHECKED BY:	APPROVED BY:	DATE: JANUARY 2023
ASSEMBLY DWG.	PREVIOUS DWG.	DRAWING NO. M7204	REVISION 1
SCALE: 1:20	ISOMETRIC: 1:20		
DO NOT SCALE THIS DRAWING			