

GENERAL NOTES

Precast concrete shall be exposure Class S and meet min compressive strength of 35MPa

Cement: Type GU
 Air Category: 4.0% - 7.0%
 Aggregate: CSA/CAN A23.4
 Maximum Size: 20mm
 Admixtures: CSA/CAN A23.4
 Reinforcing: Grade 400W CSA G30.18-09
 Inserts/Embeds: As noted in drawing details

Manufacture of precast concrete units shall be in accordance with specification CSA A23.4

**** LEKO PRECAST LTD SHALL NOT BE RESPONSIBLE FOR ANY INSTALLATION PRACTICES FOLLOWED ON-SITE UNLESS PERFORMED BY LEKO PRECAST LTD ****

Tank Volume 1,580gal (1050/532)
 Tank Weight 6,900Kg (15,175 lbs)
 Lid Weight 2,370Kg (5,220 lbs)
 Total Weight 9,270Kg (20,395 lbs)

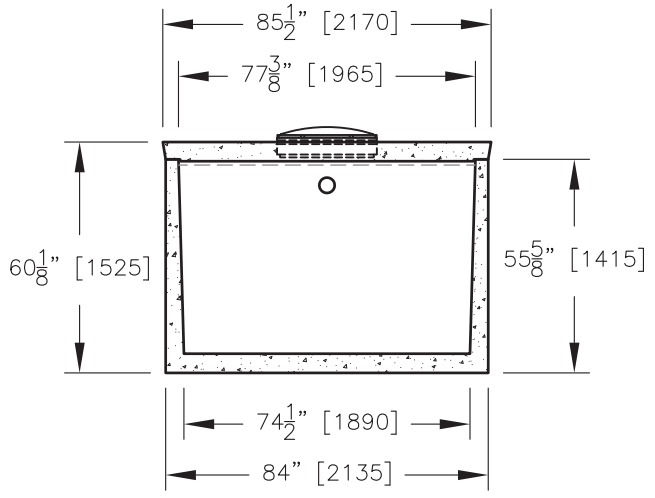
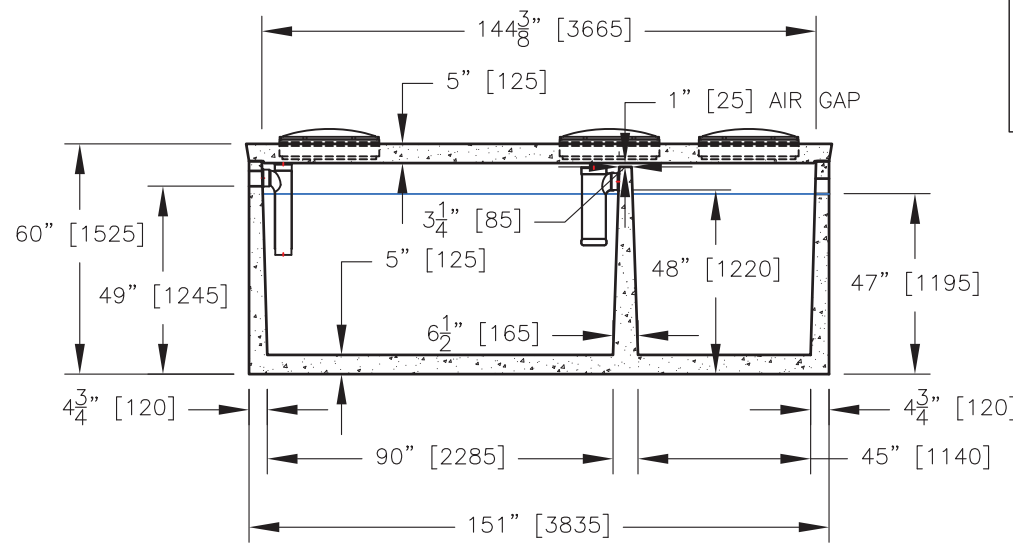

1500 IGAL PUMP OUT TANK			
DRAWN BY: JA	CHECKED BY:	APPROVED BY:	DATE: June 2017
ASSEMBLY DWG.	PREVIOUS DWG.	DRAWING NO. S0206M	REVISION 0
SCALE: 1:50	ISOMETRIC: N/A		
DO NOT SCALE THIS DRAWING			