

**GENERAL NOTES**

Precast concrete shall be exposure Class S and meet min compressive strength of 35MPA

Cement: Type GU  
 Air Category: 4.0% - 7.0%  
 Aggregate: CSA/CAN A23.4  
 Maximum Size: 20mm  
 Admixtures: CSA/CAN A23.4  
 Reinforcing: Grade 400W CSA  
 G30.18-09  
 Inserts/Embeds: As noted in drawing details

Manufacture of precast concrete units shall be in accordance with specification CSA A23.4

**\*\* LEKO PRECAST LTD SHALL NOT BE RESPONSIBLE FOR ANY INSTALLATION PRACTICES FOLLOWED ON-SITE UNLESS PERFORMED BY LEKO PRECAST LTD \*\***

Tank Volume 2,045gal (1360/685)  
 Tank Weight 7,755Kg (17,060 lbs)  
 Lid Weight 2,370Kg (5,220 lbs)  
 Total Weight 10,125Kg (22,275 lbs)

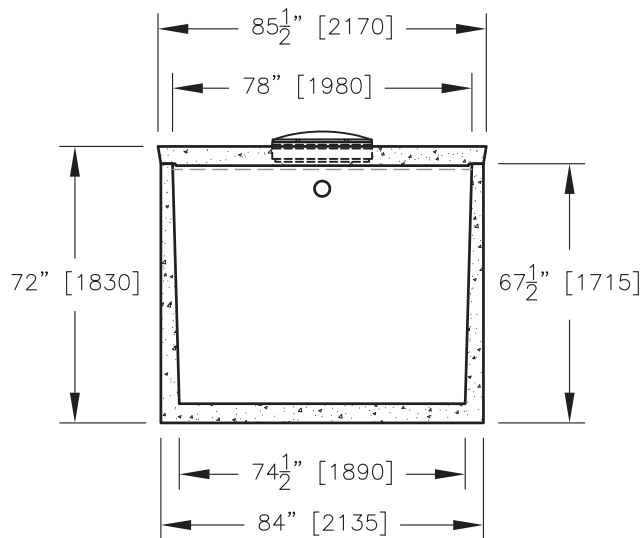
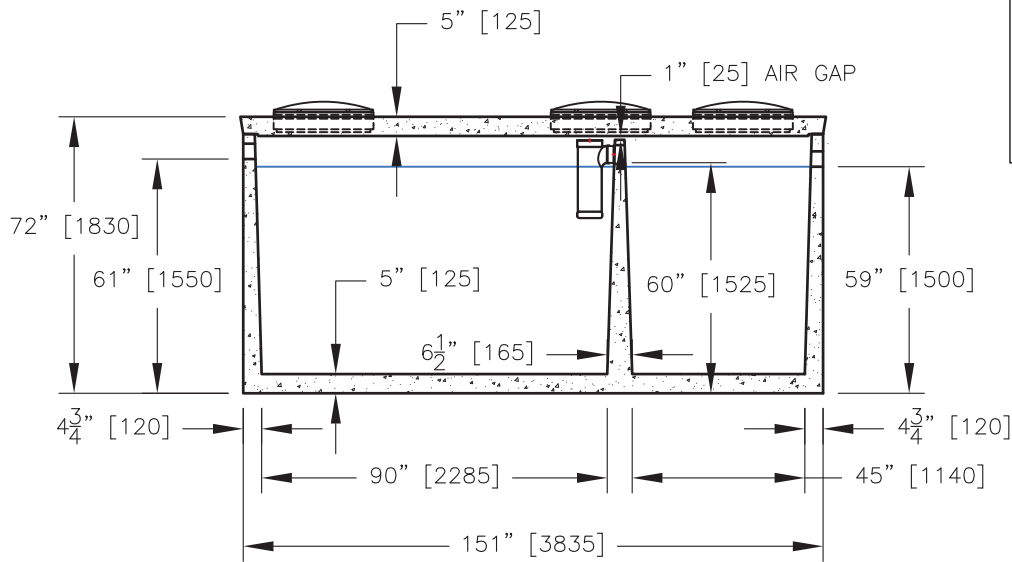

**2000 IGAL PUMP OUT TANK**

DRAWN BY: JA		CHECKED BY:		APPROVED BY:		DATE: November 2018	
ASSEMBLY DWG.		PREVIOUS DWG.		DRAWING NO. S0208M			REVISION 0
SCALE: 1:50		ISOMETRIC: N/A					
DO NOT SCALE THIS DRAWING							