

# MP-19



# Computer Storage

# Product Description

MP- 19 is an advance system, which can interlock and control the equipment in the classroom/auditorium. Through it's ergonomic design, it very for portable and sturdy. The use of high strenght steel and a premium 3 layer wood finish gives it a long lasting life. It is more advance and efficient way of storing your smart devices like computers, thin clients & etc. and with its retractable side tray, it can be used to place or store your laptop or visualiser.

# SPECIFICATIONS :

Construction:

- Mild Steel with Polymer powder coated/  
Composite Elements
- Electrical Actuator to adjust the monitor's ergonomic angle as per user convenience.
- Lockable sliding Tray for keyboard, Laptop/Visualiser, etc.
- Interface port for Laptop External Devices-Power, USB, Audio, VGA, HDMI LAN to be placed with Tray 4 Caster wheels with lock for easy movement.

# Features

## High Strength Steel Chasis



## Stainless Steel Keyboard Tray



Two colours available: White and Black

# PRODUCT STRUCTURE

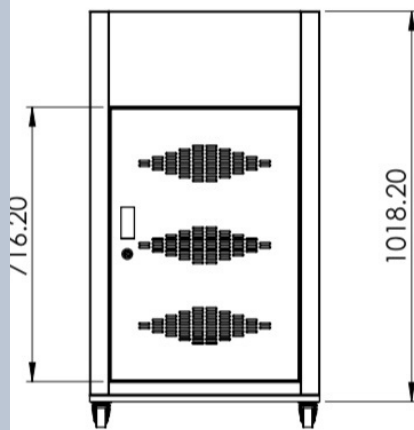
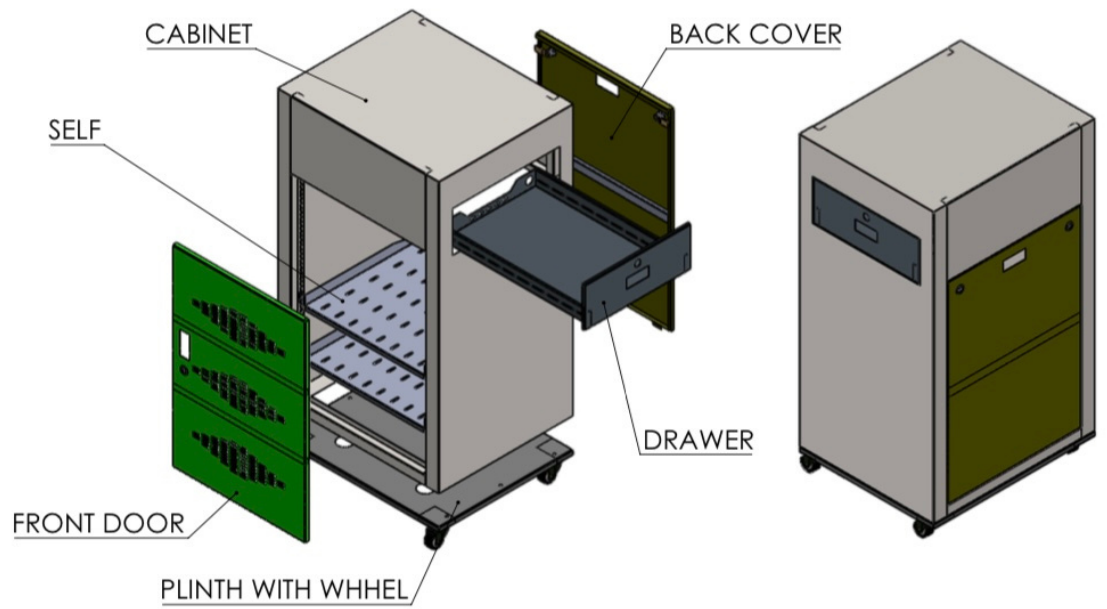

FRONT VIEW

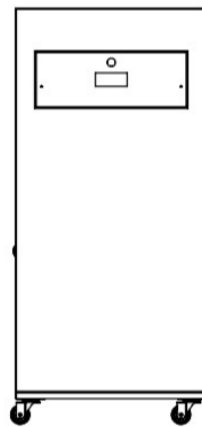

SIDE VIEW

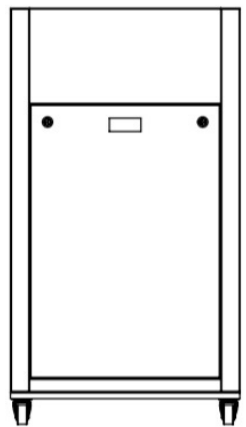

BACK VIEW