



CDVI

Security to Access

A22K

**High Security Access Control
2-Door/4-Reader Module**



TRIUM
ACCESS CONTROL



KRYPTO
HIGH SECURITY SOLUTION

www.cdvi.com

Thank you for buying our products and for the confidence you placed in CDVI.

1] PRODUCT PRESENTATION	3
2] NOTES AND RECOMMENDATIONS	4
FCC & IC Compliance	4
UL Compliance	4
UL 294 Compliance Notice	4
Free Technical Support	5
Recommended Wiring	5
Specifications	5
Communication	6
Power Supply	6
On-Board Protection	6
Power Output Specifications	6
3] PACKAGE CONTENTS	7
Location and Mounting	8
4] MOUNTING INSTRUCTIONS	9
Installing the Tamper Switches	9
Installing the box lock	12
Fixing the Box to its Location	13
Installing the A22K PC board	14
5] WIRING DIAGRAM	15
A22K Network Connectivity Wiring Diagram	16
Box Tamper Switches	18
Readers and Keypads	19
Inputs	21
Door Lock Devices	24
Power Supply	26
Battery Backup	29
LED Indicators	30
Ethernet Network Connection & RS485 BUS	31
Reset to Factory Default	33
RS485 BUS Topologies	34
System Overview	35
6] PROGRAMMING	36
Card Enrollment Procedure (add or delete cards without a computer)	36
7] WARRANTY - TERMS & CONDITIONS	37

Copyright (C) 2026 CDVI. All rights reserved. ATRIUM Access Control is protected by copyright law and international treaties. Unauthorized reproduction or distribution of this product, or any portion of it, may result in severe civil and criminal penalties, and will be prosecuted to the maximum extent possible under law.

All other brand and product names are trademarks or registered trademarks of their respective companies.

The information contained in this publication is subject to change without notice.

1] PRODUCT PRESENTATION

The A22K is ATRIUM's powerful Web-Based high security module. The flexibility of the A22K module allows it to be set either as a 2-door controller or expander (2 in 1). The A22K includes an embedded web server that combines performance and simplicity enabling you to manage Users/Cards, lock or unlock doors, view and print system events and display controller information from any place in the world! Industry-unique and effortless card enrollment mode minimizes system start up and simplifies your life. A pre-assembled universal power supply is included with every A22K making this unit an industry leader in efficiency and simplicity.

- **Control 2 doors / 4 readers, Entry/Exit per reader port (Wiegand or Auto-recognition High Security RS485 port)**
- **Embedded Web Server (Secure https Ready)**
- **Pre-assembled universal power supply with AC wall plug (Also available with PoE+ Splitter: A22KPOE)**
- **On-board Ethernet Port with AES 256-bit encryption**
- **Auto-detect hardware modules (No DIP Switches)**
- **Lock outputs: 2 (750mA @ 12VDC/each)**
- **Converts to an A22KEC elevator controller with free firmware (Once converted the A22KEC can manage up to 256 floors)**
- **Relay Outputs: 2 Form C relays (Dry Contact) 5A @ 250VAC, 7A @ 125VAC, 7A @ 30VDC**
- **Quick and easy card enrollment mode**
- **6 Multi-purpose inputs (12 using zone doubling)**
- **OSDP-2 compatible**
- **IPV6 compatible**
- **Totally fuseless system**
- **10,000 users**
- **10,000 cards**
- **10,000 keypad user codes**
- **25,000 event buffer**
- **100 holidays**
- **1000 access levels**
- **256 floor levels**
- **250 schedules each supporting 100 time periods**
- **Full calendar with leap year support**
- **Firmware upgradable**
- **FREE management software**
- **Maintenance-friendly snap on terminal connectors**
- **Comprehensive LED status indicators**

KRYPTO
HIGH SECURITY SOLUTION



2] NOTES AND RECOMMENDATIONS

FCC & IC COMPLIANCE

This device complies with Part 15 of the FCC rules Class A. Operation is subject to the following two conditions: (1) this device may not cause harmful interference, and (2) this device must accept any interference received including interference that may cause undesired operation. This class A digital apparatus meets all requirements of the Canadian Interference Causing Equipment Regulations. The C24K is also compliant with EN55022:1998, amendment 1:1995, Class A.

UL COMPLIANCE

To comply with UL listings, the following requirements must be met:

- Use of UL listed readers
- Use of a UL recognized tamper switch on every housing cabinet for the A22K
- Use only UL listed cables
- Use only UL listed adaptors

Note: All circuits are power limited.

UL 294 COMPLIANCE NOTICE

CDVI declared the following levels: Destructive Attack Level I, Line Security Level IV, Endurance Level IV, Standby Power Level IV.

- Use only UL listed power supply
- Connect CDVI LED status indicator, part number 7020-0001-0000, to the DC Input gray terminals of the A22K.



Backup battery provides operation of up to 12 hours but has been tested for 4 hours per Section 33 of UL 294, fifth edition.



The system's location and wiring methods shall be in accordance with the National Electrical Code, ANSI/NFPA 70.



Operation of the product shall not prevent the functionality of the emergency exit functions.

FREE TECHNICAL SUPPORT

For technical support in Canada or the U.S., call 1-866-610-0102, Monday to Friday from 8:00 a.m. to 8:00 p.m. EST. For technical support outside these regions, refer to the last page of this document or visit our website: www.cdvi.ca

RECOMMENDED WIRING

Equipment	Wire Type	Size	Maximum Length
RS485 card reader (High Security Reader)	4 conductors, shielded copper	26AWG (0.40 mm) to 18AWG (1.02 mm)	1220 m (4000 ft.)
Wiegand card reader and keypad	4 to 8 conductors, stranded, shielded (foil), drain conductor. For example: Alpha 5196, 5198, 5386, 5388, Belden 9553	22AWG (0.64 mm) to 18AWG (1.02 mm)	150 m (500 ft.)
Zone input	2 conductors, copper 22AWG (0.64 mm)	22AWG (0.64 mm)	600 m (2000 ft.)
Door strike	2 conductors, solid copper 18AWG (1.02 mm)	18AWG (1.02 mm)	150 m (500 ft.)
Power Supply*	3 conductors, solid copper 18AWG (1.02 mm)	14AWG (1.63 mm)*	8 m (25 ft.)
Ethernet	CAT 5/5e	-	100 m (300 ft)
RS485 bus, Star or Daisy Chain (no BIAS/EOL required)	CAT 5/5e or 4 pairs	24AWG (0.51 mm)	1220 m (4000 ft.)
	4 conductors, copper	26AWG (0.40 mm) to 18AWG (1.02 mm)	

* The Minimum Size Equipment Conductors for the AC mains required are 14 AWG if made of Copper or 12 AWG if made of Aluminum or Copper-Clad Aluminum. Do not use any switch-controlled outlets to power the system.

SPECIFICATIONS

System Resources	
Doors	2 (expandable to 10 doors)
Cards / Users	10,000 cards / users
Schedules	250 Schedules each supporting up to 100 time periods (dd, hh:mm)
Buffered Events	25,000 events
Holidays	100 holidays
Access Levels	1000 access levels
Power Rating	250 mA @ 24 Vdc
Operating Temperature	-20°C to +50°C (-4°F to +122°F)
Humidity	0% to 85% (non condensing)
System Autonomy	Full Distributed Architecture (100% Off-line Operation)
Firmware	Online Upgradeable
PCB Dimensions	19.9cm (7.83") x 12.38 cm (4.875")
Cabinet Dimensions	29 cm (11.4") high, 28 cm (11") wide, 8 cm (3.15") deep

Inputs	
Readers	2 x Wiegand Readers with Multiple Protocol Support (Wiegand 26-bit, 30-bit & 44-bit) or 4 x Auto-recognition High Security RS485 ports (if set as entry/exit door)
Keypads	2 x Wiegand Keypad with Multiple Protocol Support (Wiegand 8-bit & 26-bit)
Multi-Purpose Inputs	6 zone inputs (up to 12 using ZONE DOUBLING) supporting individual WIRE CUT & WIRE SHORT supervision.
Box Tamper	Normally Closed (N.C.) contact

Communication

LOCAL BUS	RS485 @ 57600Baud supporting star and/or daisy chain topologies up to 4000ft (1220 meters)
ETHERNET	10/100 Base-T, Auto Sensing, 100m(300ft)

Power Supply

AC Power	120-240Vac
Frequency	50Hz/60Hz
Output	24Vdc, 2.5A
AC Terminal Fuse	250Vac, 2.5A, Time Lag, Slow Blow, Operating Temperature: -55°C to +125°C
Power Loss Indicator	Yes (DC IN)



Do Not Connect to a Receptacle Controlled by a Switch.
Other 24Vdc, 2.5A output UL/ULC certified transformer can be used.

On-Board Protection (All fuseless, auto-resume)

LK1, LK2	12Vdc @ 750mA
AUX	12Vdc @ 1A
Battery	Against reversal, short, current limited/monitored

Power output specifications

Battery Backup

Battery Capacity	One 12Vdc 7Ah rechargeable acid/lead or gel cell backup battery (UL/ULC: YUASA #NP7-12 recommended, Europe: CDVI B7AH recommended). Ensure proper polarity.
Charging Current	250mA (default), 500mA, or 1A. Refer to the Cloud-Based system manual to modify the battery charging current.
Low Battery @	11.8Vdc
Low Battery Restore @	12.2Vdc
Low Battery Cut-Off @	10.5Vdc

Power Outputs (+12Vdc)

Lock Output LK1	Maximum Current 750mA each
Lock Output LK2	
Reader 1	Maximum Current 1000mA
Reader 2	
Zone Inputs	
LOCAL BUS	

Outputs

RLY1, RLY2	Form C Relay, 5A @ 250Vac, 7A @ 125Vac, 7A @ 30Vdc
------------	--

3] PACKAGE CONTENTS

This chapter details how to install and setup the ATRIUM A22K .

The A22K contains:

- One A22K module in its cabinet with connection diagram label
- Pre-assembled universal power supply with AC power cord plug
- Metal Box kit (See below)
- Installation kit (See below)

Metal Box Kit	Wall Switch and a white wire (115mm)	3 wires for tamper switch (2 x 360mm and 1 x 165mm)	Bolts and Nuts	Wall Switch Spacer	Door Switch and 2 white wires (350mm)	Door Switch Support	Metal box screw for door enclosure	Metal box lock and key
	1	3	2 each	1	1	1	4	1

Installation Kit	Red and black wires, for backup battery (400mm)	1K Resistor	2.2K Resistor	Diode 1N4007 for DC door strikes or maglocks	Varistor for AC door strikes or maglocks	Fastener (PCB Holder)
	1 pair	22	10	2	2	7

If any item is missing, please notify your distributor immediately.

LOCATION AND MOUNTING

The cabinet is designed to be installed indoors, in a safe and secure location. Suggested locations include electrical rooms, communication equipment rooms, closets or in the ceiling. To save time, wiring and facilitate testing, install the cabinets at an equal distance between its controlled doors. Normal temperature and humidity levels should be maintained.



Please note that other approved cabinets with approved tamper switch on the front cover and rear surface can be used.

Cabinet Dimensions:

29 cm (11.4") high, 28 cm (11") wide, 8 cm (3.15") deep

The Cabinet Can Accommodate:

One 12V DC @ 4.5AH or 7AH, gel cell type batteries and wiring connections (15cm (6") high, 6cm (2.5") wide, 9 cm (3.54") deep)

Battery Model	Voltage	Capacity	Length	Width	Height
YUASA #NP7-12	12 Volt	7 Ah	151mm (5.94")	65mm (2.56")	97.5mm (3.84")
YUASA #NP4-12	12 Volt	4.5 Ah	90mm(3.54")	70mm (2.76")	106mm (4.17")

Multiple Conduit Knock-outs:

Two 19.05mm (0.75") on each side and one 12.7mm (0.5") on top

Minimum Clearance For Cabinet:

25cm (10") clear space around all sides

38cm (15") clear space in front of cabinet

Minimum Clearance From Electrical Interference:

2.4m (8') from high voltage equipment or wiring and from electrical equipment likely to generate interference

1.2m (4') from telephone equipment or lines and 8m (25') from transmitting equipment



The system's location and wiring methods shall be in accordance with the National Electrical Code, ANSI/NFPA 70.

4] MOUNTING INSTRUCTIONS

The box needs to be prepared before fixing it to its location.

INSTALLING THE TAMPER SWITCHES

Installing tamper switches allows the A22K to detect when the cabinet door is opened and/or when the cabinet is removed from the wall. If needed install the tamper switch(es) as follows:

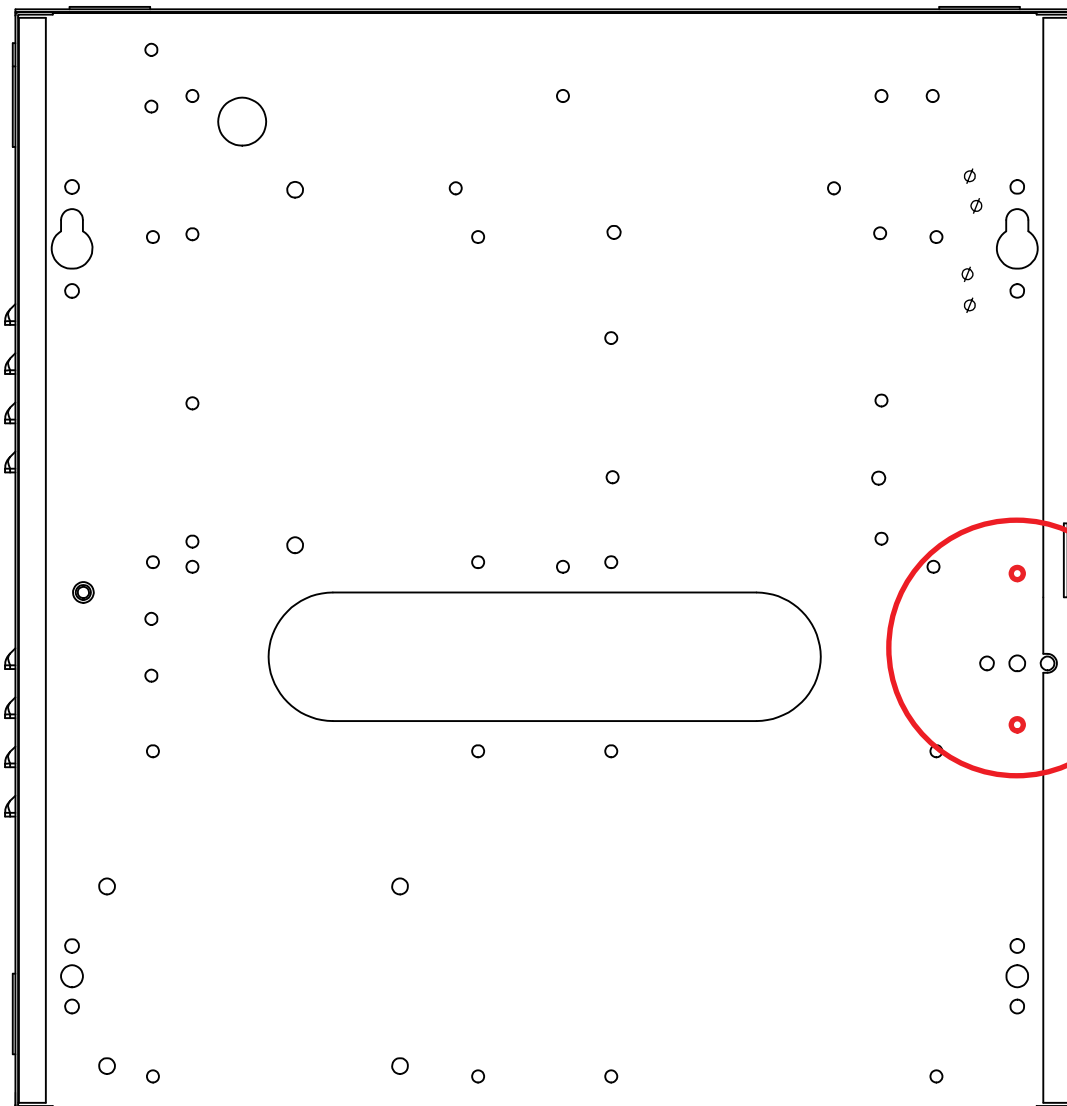

Metal box
holes where
to fix the wall
tamper switch

Install the wall tamper switch using the supplied bolts and nuts as shown in the following picture.

Install the tamper switch plastic spacer on the back at bottom left side of the box as show in the following picture.

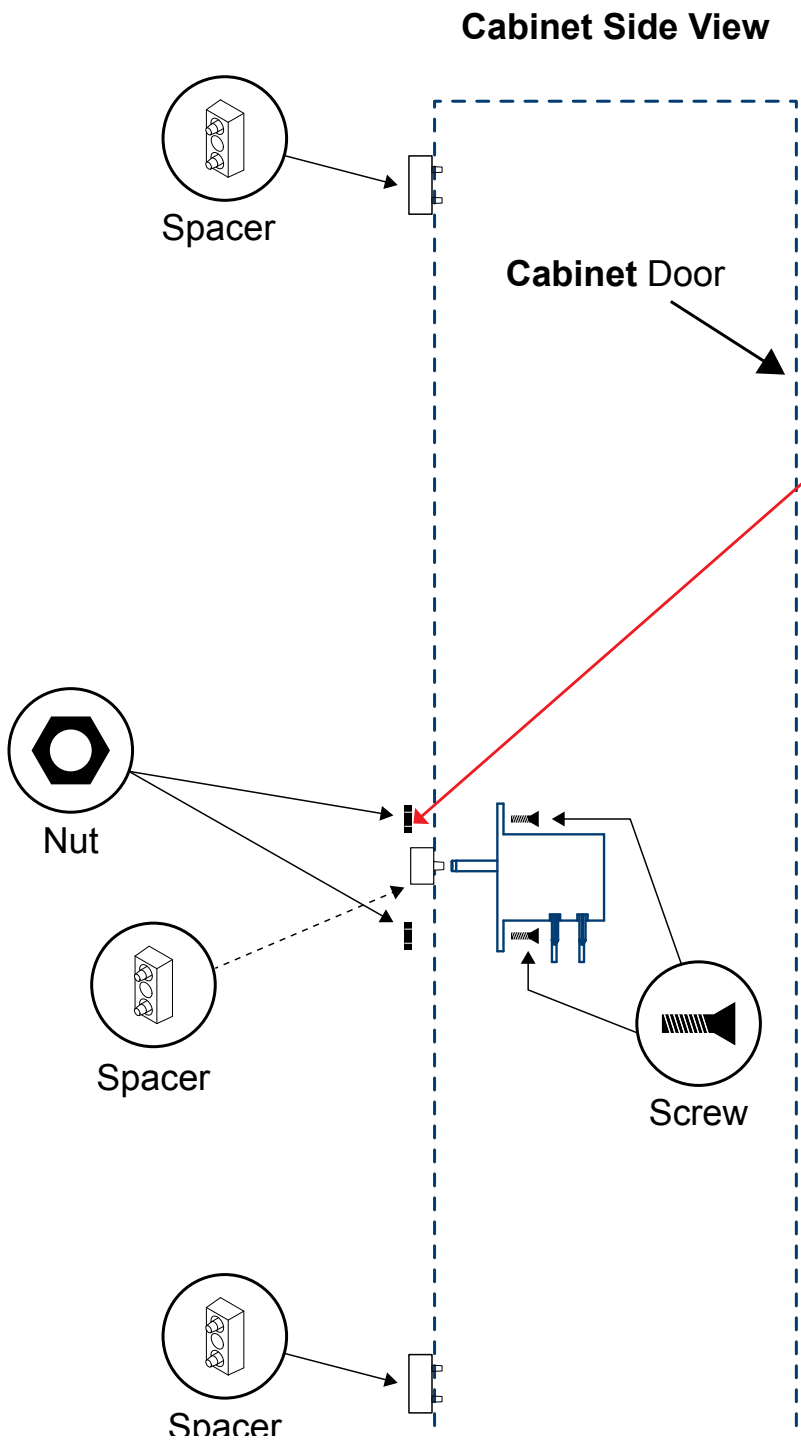

Install the door tamper switch by aligning the switch holes to the pre-installed plastic bracket pins. Press firmly to secure the tamper switch in position, then fix the bracket to its mounting flange.

Refer to page 16 for wiring diagram.

Fix the tamper switch to the bracket then mount the bracket on the mounting flange

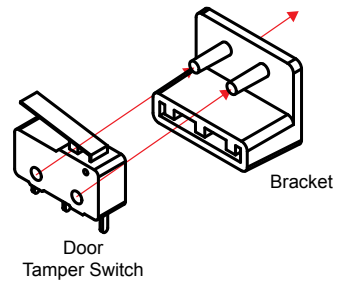
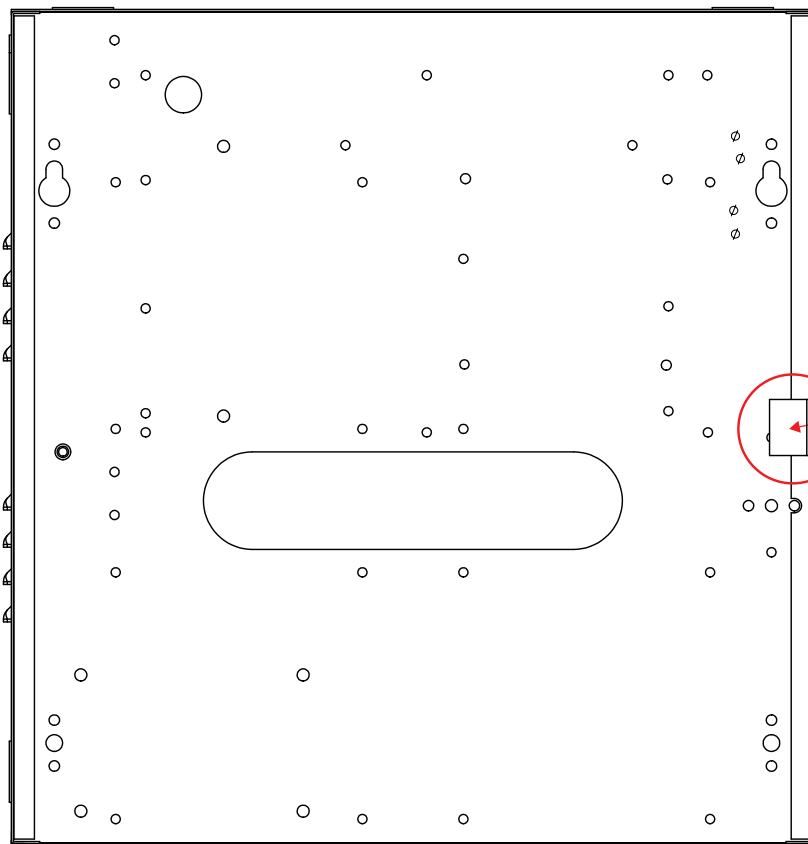

Door Tamper Switch Mounting Flange



INSTALLING THE BOX LOCK

Installing the box lock allows to secure the box from unauthorized access. Installation procedure:

1. Remove the box door knock-out.
2. Insert the lock in the hole.
3. Slide the "U" metal part into the lock groove to secure the lock in place.

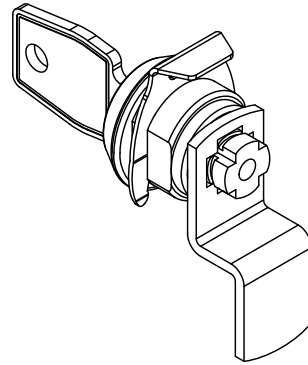

Alternatively or complementary to the box lock, the box may be secured by fixing the cover to its base using screws.

However this should be done only once the installation is completed.

1. Use the 4 screws supplied to secure the box cover to its base as shown in the following picture.

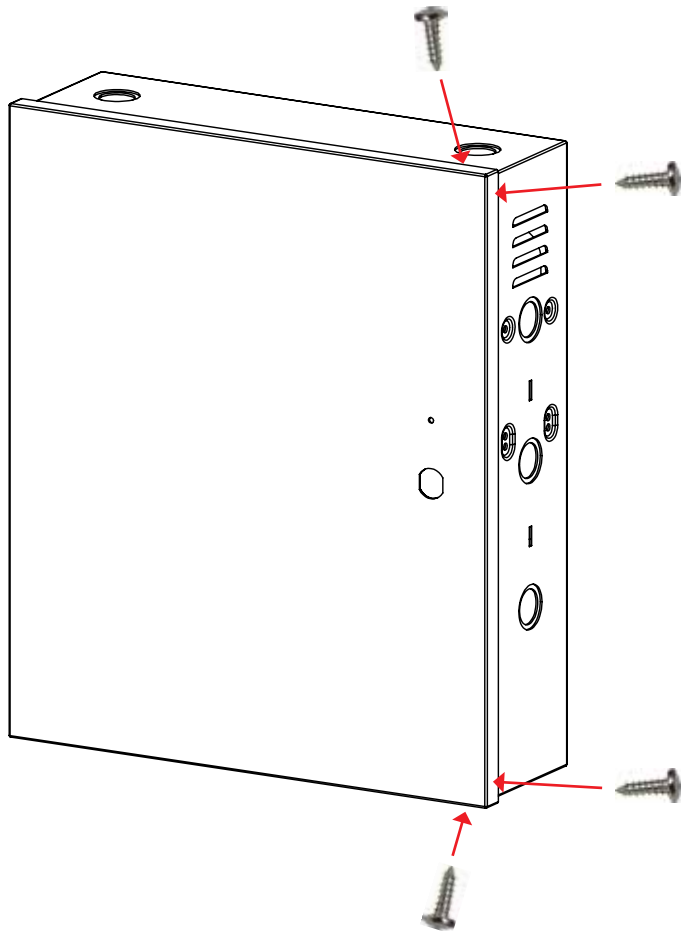

FIXING THE BOX TO ITS LOCATION

Install the box to its location using 4 screws (not supplied) as shown in the following picture.



If the wall tamper switch is used, make sure that the tamper switch arm moves freely and is completely pushed in when the enclosure is installed on the wall.

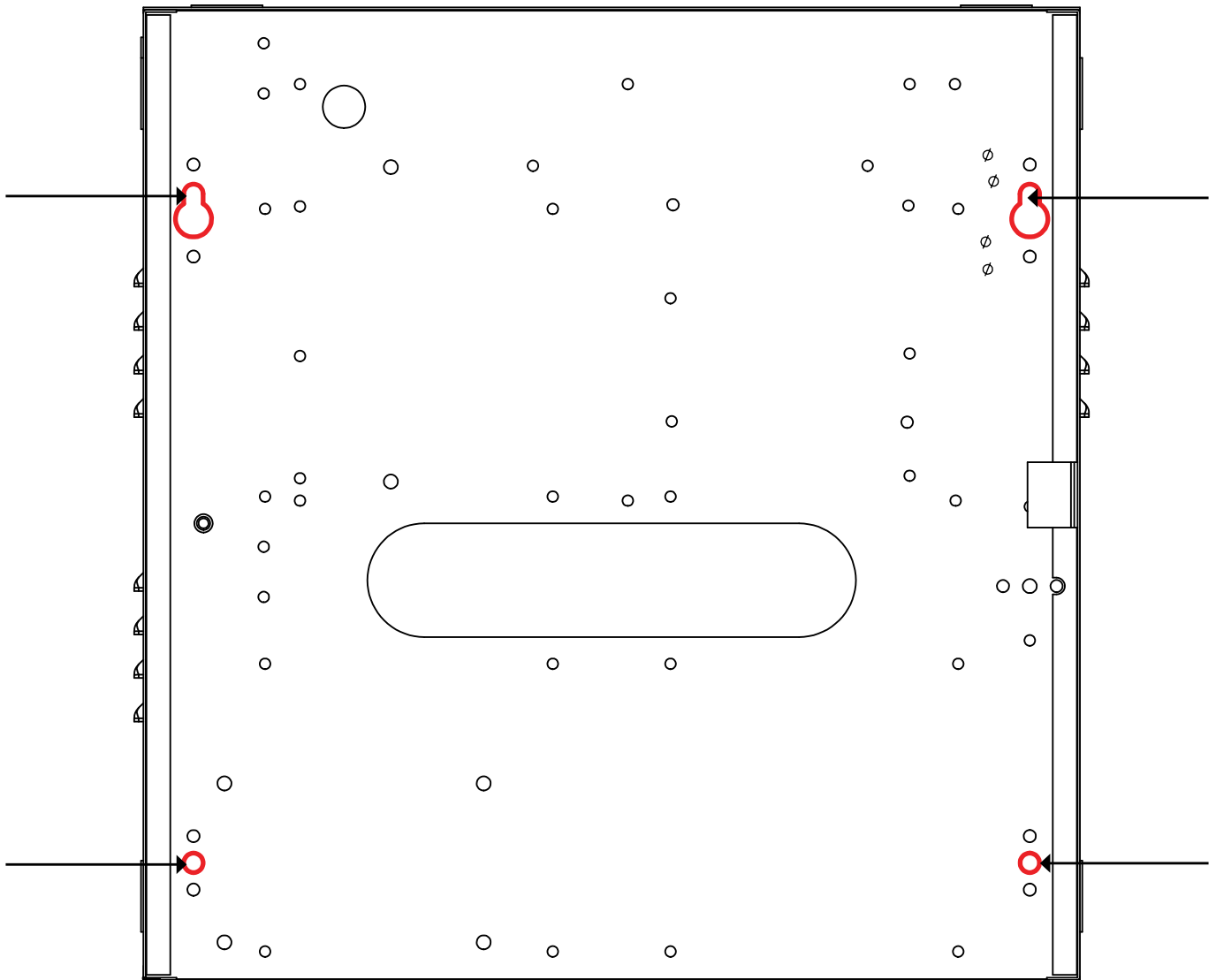

INSTALLING THE A22K PC BOARD

Install the 5 fasteners (PCB holder) supplied respectively to the box holes identified in red in the following picture. Install the A22K PCB by aligning the fasteners with the corresponding PCB holes and pressing firmly to secure the PCB in place.

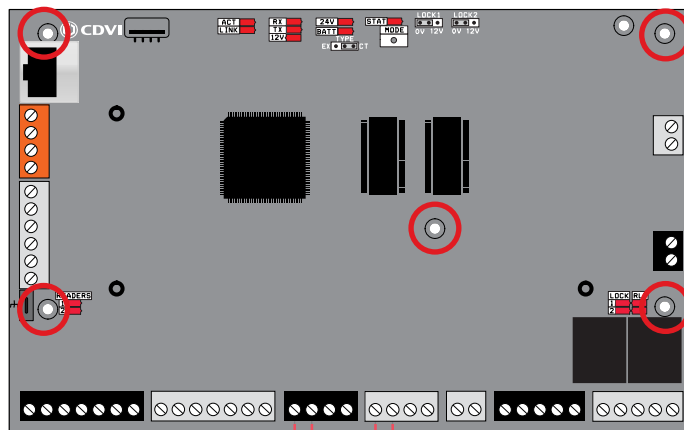
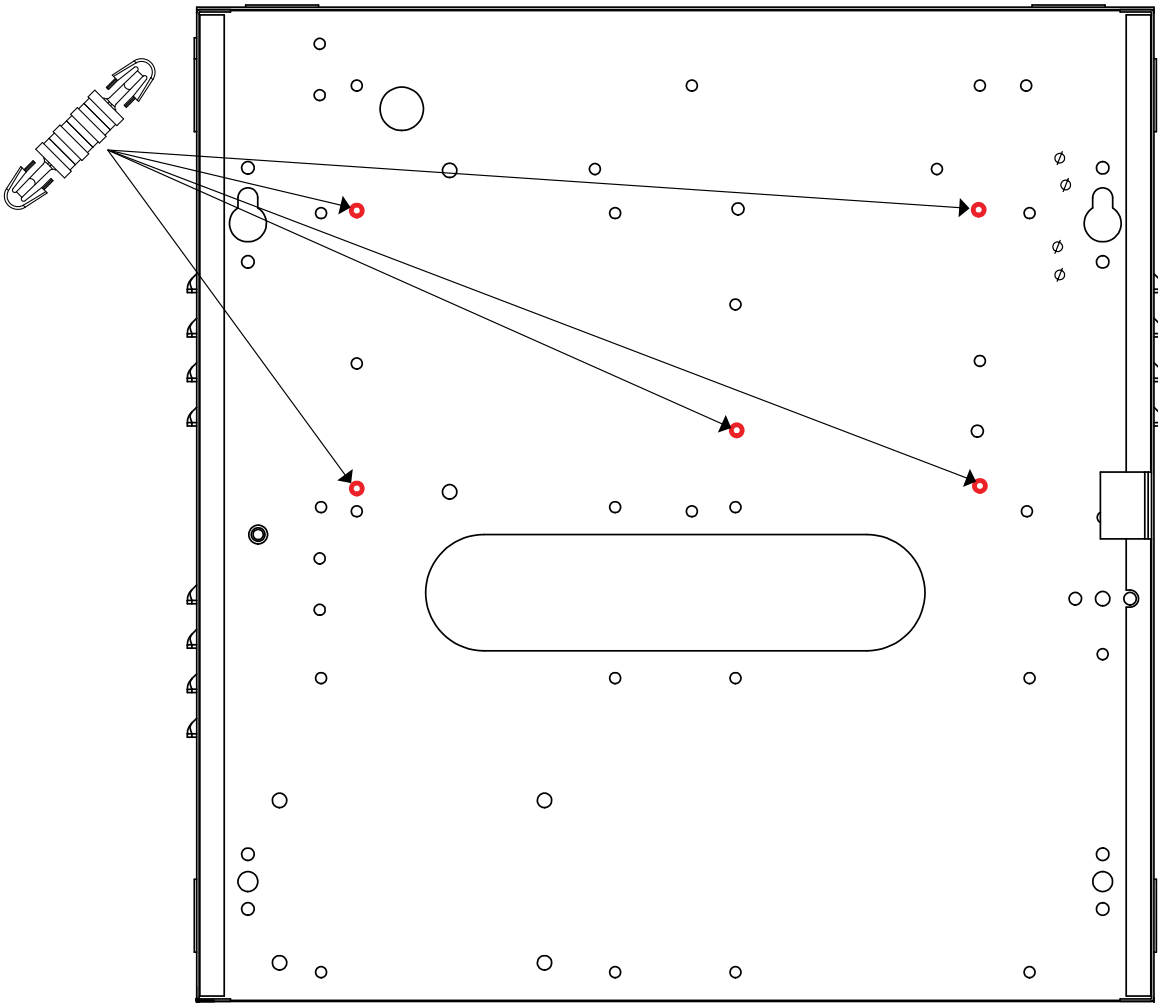

5] WIRING DIAGRAM

Out of the box the A22K is ready for IP connectivity, fifty (50) A22K per account. If you have more than one A22K controller per account, one must be set as the **"Master"** controller to manage the others. These forty (49) others are defined as **"Sub-Controllers"**.

The flexibility of the A22K module allows it to be set as an **"Expander"**. Up to four (4) A22K set as an **"Expander"** can be connected to the RS485 Local Bus (orange connector) of a **"Master"** or **"Sub-Controllers"**. ATRIUM can support a total of 500 doors (100 doors connected IP + 400 doors connected RS485). Simply adjust the "Module Type" jumper setting as shown below.

Module Type Jumper Setting (Controller or Expander)

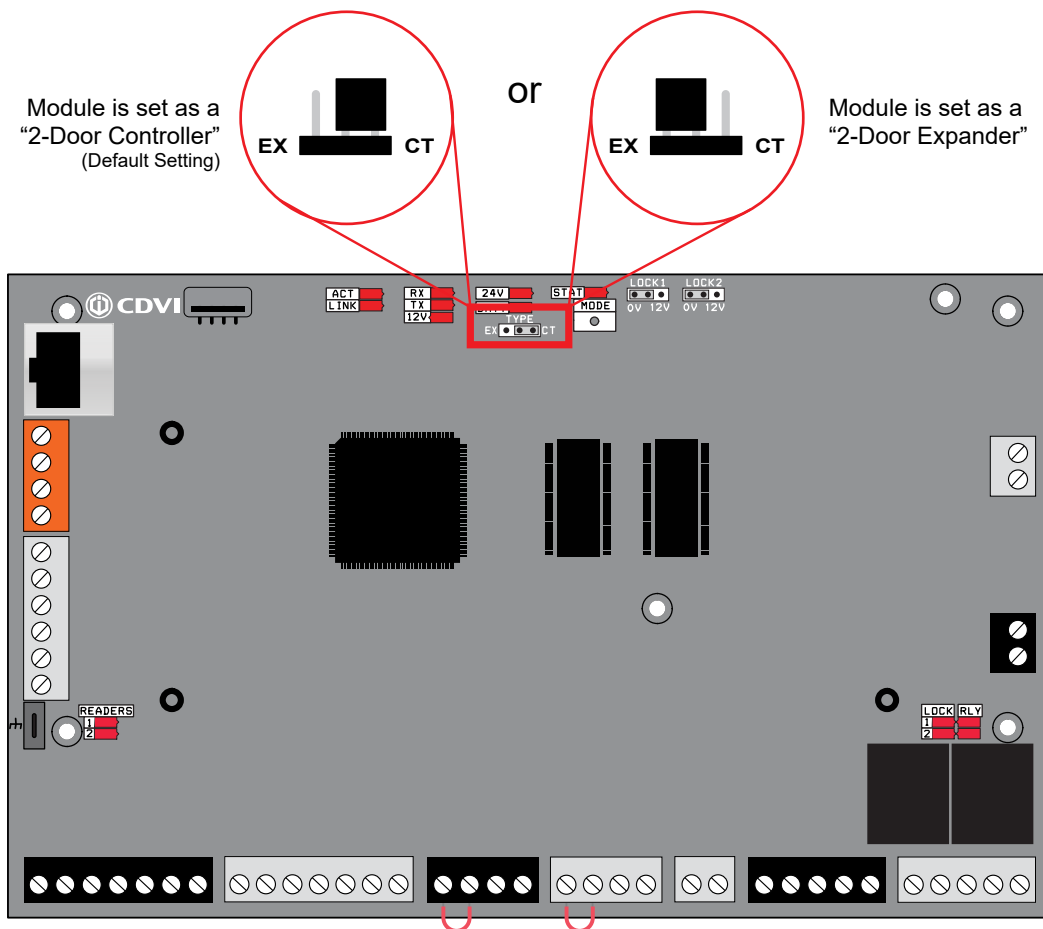

A22K NETWORK CONNECTIVITY WIRING DIAGRAM

IP CONNECTIVITY

Out of the box the A22K is ready for IP connectivity, fifty (50) A22K per account.
If you have more than one A22K controller per account, one must be set as the "Master" controller to manage the others. These forty-nine (49) others are defined as "Sub-Controllers".

"MASTER" CONTROLLER

The "Master" controller manages up to forty-nine (49) "Sub-Controllers". (100 doors fully IP)

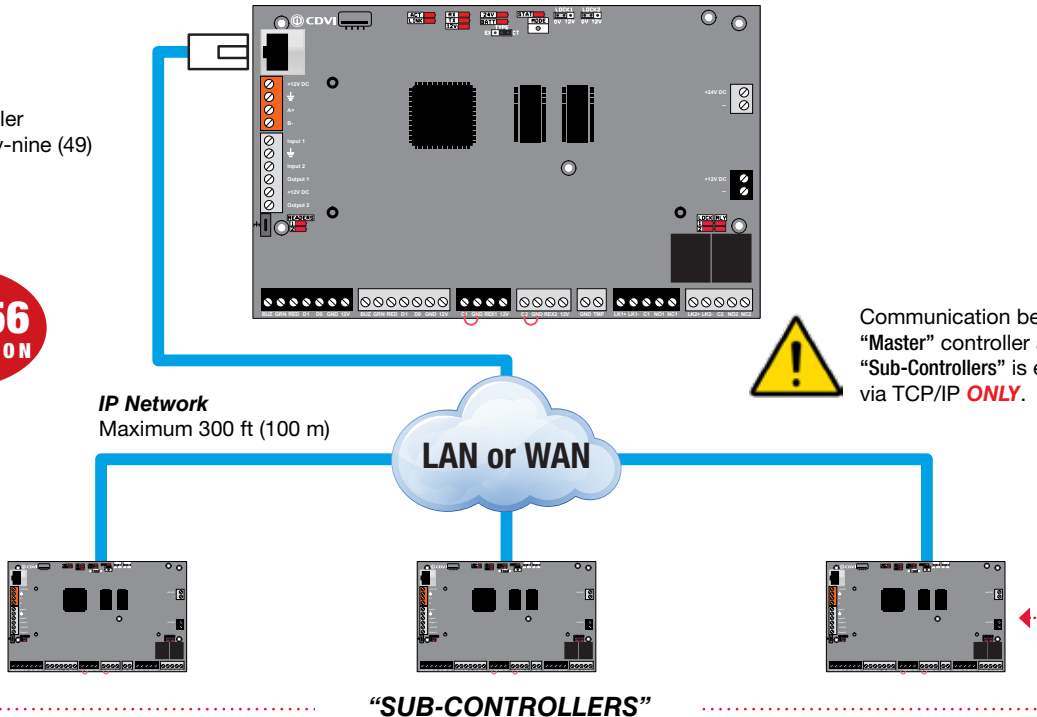

Up to forty-nine (49) A22K defined as "Sub-Controllers".

RS485 CONNECTIVITY

An A22K can be set as an "Expander". Up to four (4) can be connected to the RS485 network (orange connector) of the "Master" and each "Sub-Controller".

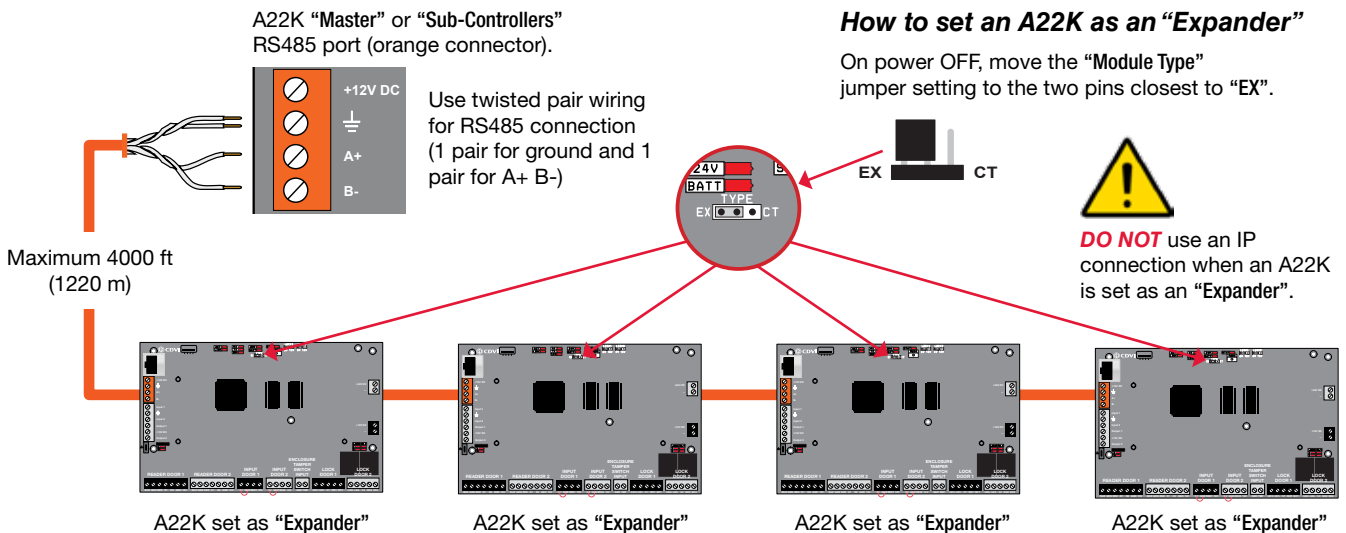



Maximum
100m (300 ft).

IP Network

A22K set as "Controller" is connected on a network (LAN or WAN) and manages all the modules connected to its RS485 port.

Up to 50 **A22K set as "Controller"** can be connected per site for a maximum of 500 doors.

When there is more than one controller per site, one must be designated as the **"Master Controller"**. It will be the link between the software (or web server) and all modules.

See the ATRIUM software manual or web server guide on how to designate an A22K controller as the **"Master Controller"**.

RS485 BUS

Up to four (4) **A22K set as "Expander"** can be connected per RS485 port.

DO NOT use IP port.

Maximum 1220m (4000 ft).

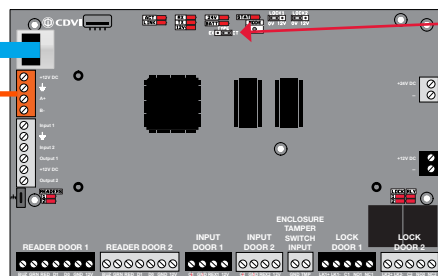

Module Type Jumper Setting at:

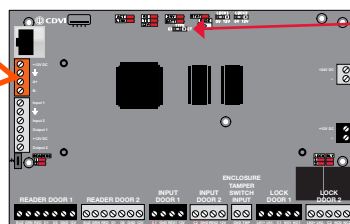

Module Type Jumper Setting at:

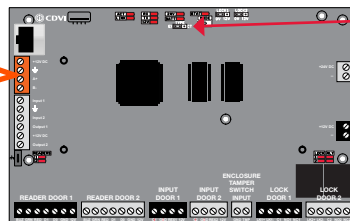

Module Type Jumper Setting at:

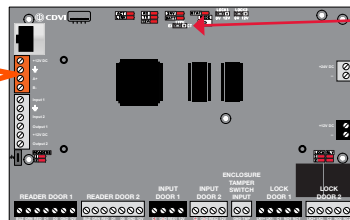

Module Type Jumper Setting at:

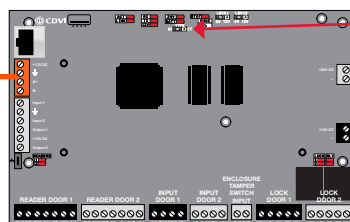

Module Type Jumper Setting at:



BOX TAMPER SWITCHES

Connecting the tamper switches allows the A22K to detect when the cabinet door is opened and/or when the cabinet is removed from the wall. To install the tamper switches, see "Installing the Tamper Switches".

To use both switches:

1. Connect one end of the supplied wire to the door tamper switch terminal and the other end to the wall tamper switch terminal.
2. Connect the other terminal of the door tamper switch to the "TMP" terminals using the supplied wire.
3. Connect the other terminal of the wall tamper switch to the "GND" terminals using the supplied wire.

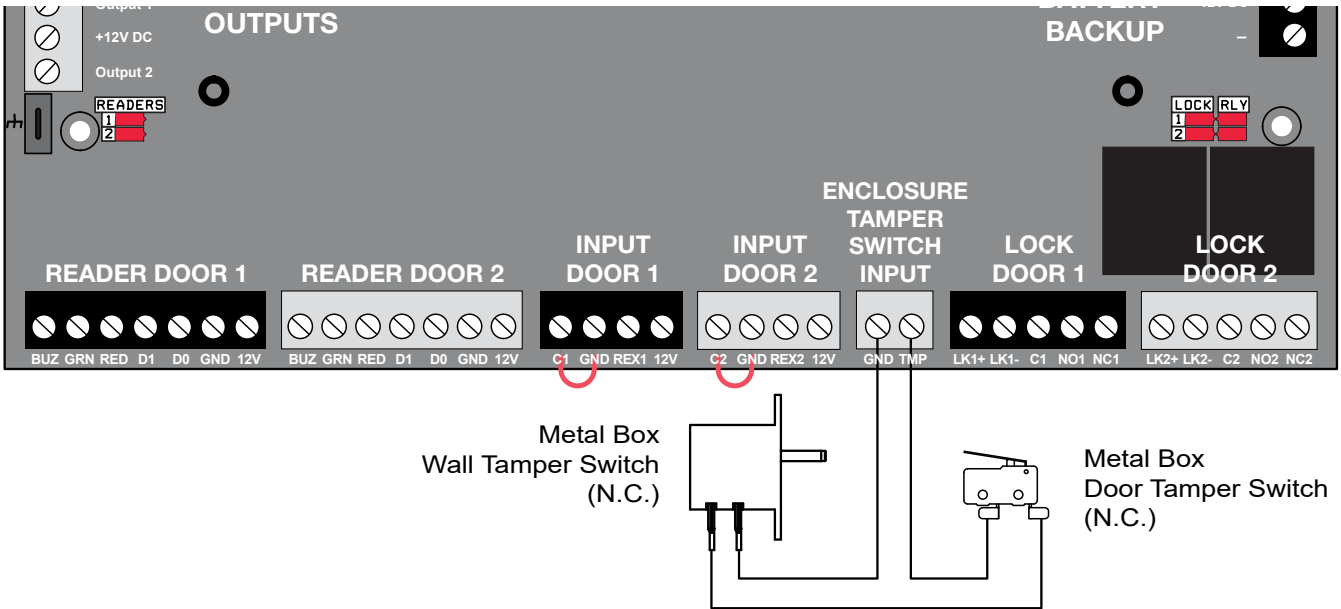

To use only one switch:

1. Connect one terminal of the tamper switch to the "TMP" terminals using the supplied wire.
2. Connect the other terminal of the same tamper switch to the "GND" terminals using the supplied wire.



If you do not use the tamper switch, connect a wire between the "TMP" and "GND" terminals.

READERS AND KEYPADS

The A22K allows automatic format detection and decoding of the connected reader/keypad. When installing a keypad with a Wiegand output, the keypad's "D0" and "D1" wires should be connected to the same terminals as the reader (the reader or keypad LED and buzzer outputs must be open collector).

The ATRIUM system is configured by default for the KRYPTO card readers and keypads, and our most popular Wiegand models which display a bright blue backlight in standby mode. Other popular Wiegand readers and keypads are also supported. Contact us to confirm compatibility. Most readers and keypads have built-in buzzers and LEDs. These should be connected to module's programmable outputs (B1, G1, R1 for READER 1 and B2, G2, R2 for READER 2). These are open collector outputs capable of sinking 100mA. Please note that the B, G and R outputs are programmed for a 7-wire reader by default.

Reader LED status:

Standby: LED indicator is steady blue

Access granted: LED indicator changes from blue to green

Access denied: LED indicator changes from blue to flashing red

Door unlocked by a schedule: LED indicator changes from blue to brief green

Typically, the reader buzzer or an external sounding device will inform the card user that the door has been left open after a valid access or that the door has been forced open. The functions of all these outputs are programmable through the ATRIUM software.

RS485 High Security Card Reader wiring diagram (shown with KPROX reader):

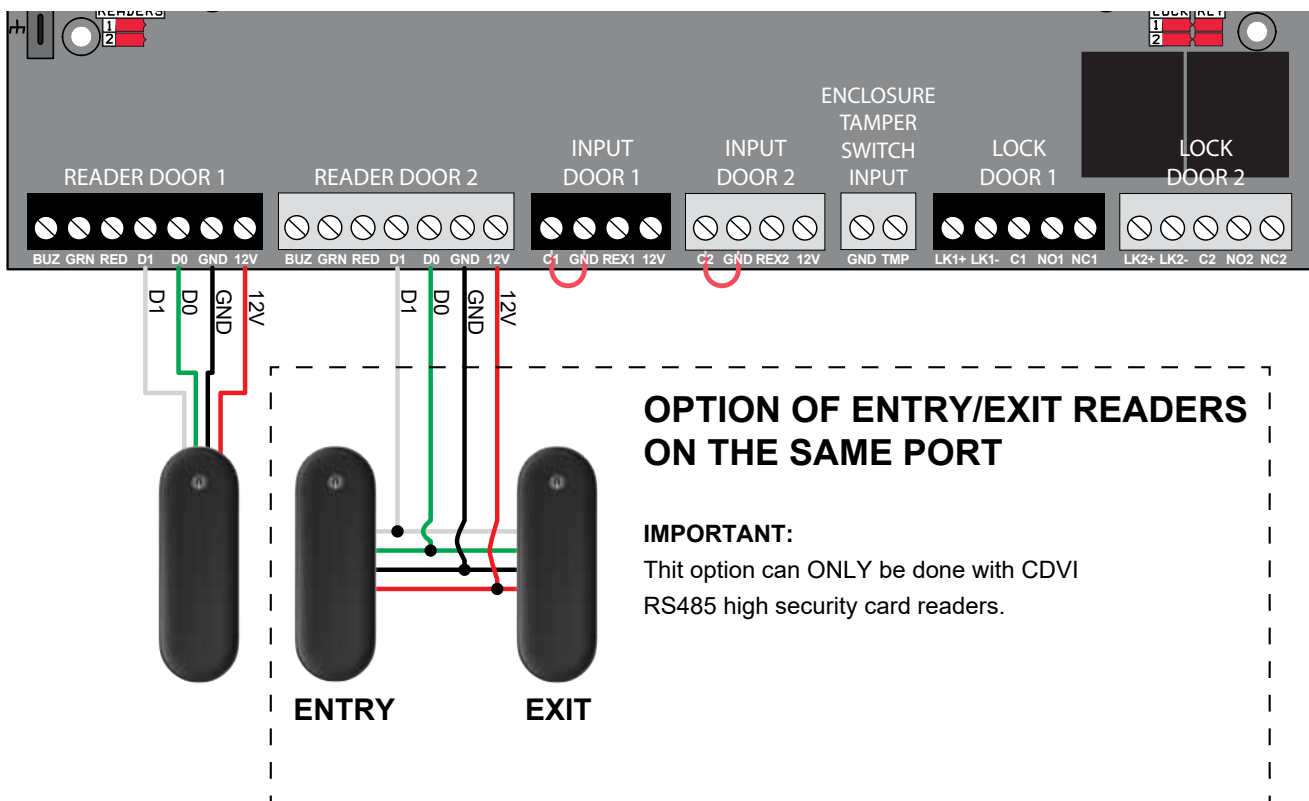

Wiegand Reader/Keypad Wiring Diagram:

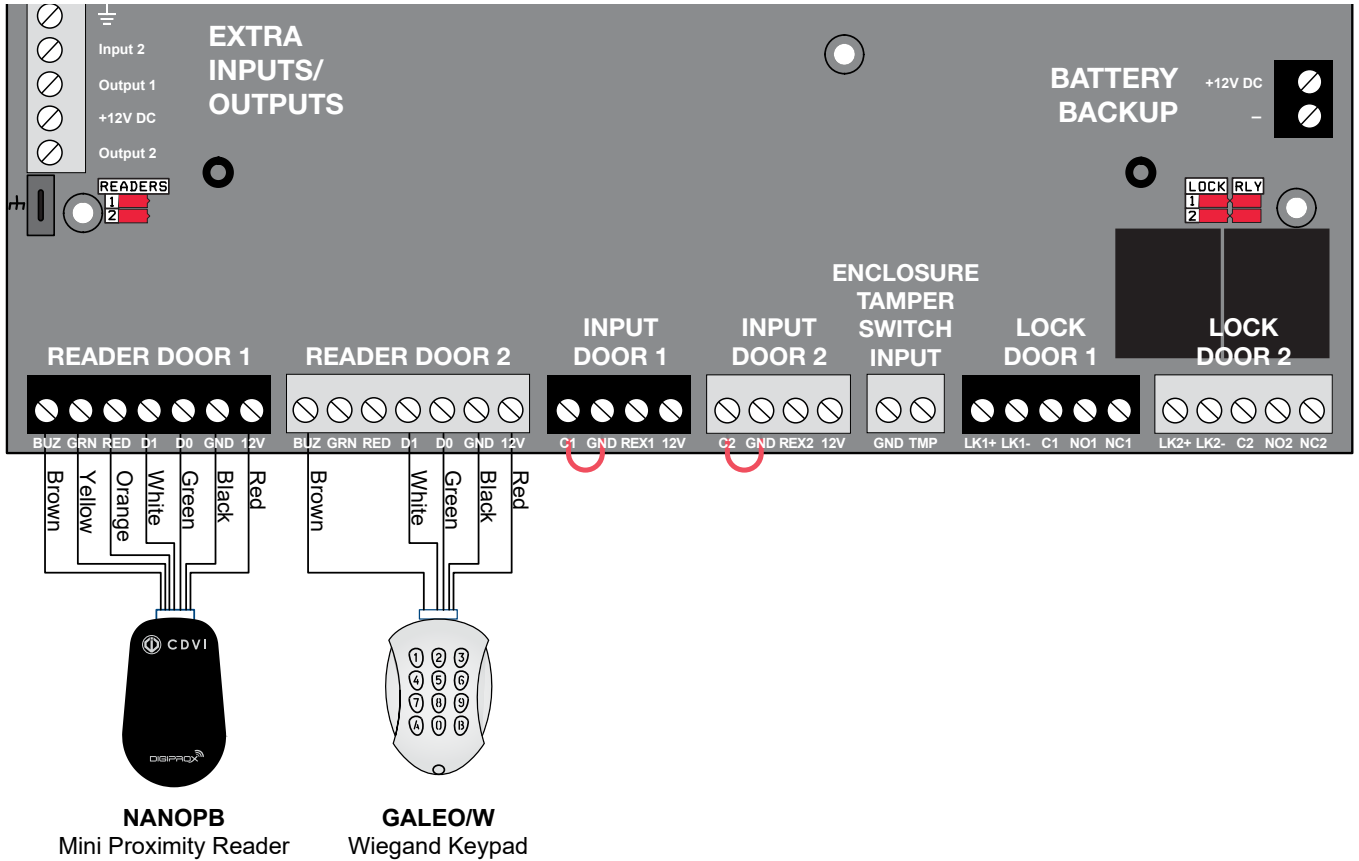

See chapter 2 "Recommended Wiring" for more information on wiring type, size, and maximum length.



The optional entry/exit readers on the same port are not compatible with Wiegand readers.



Please note that the A22K provides 12Vdc output. Connecting a device (keypad or reader) requiring a different voltage may damage the reader or keypad and void the A22K warranty.

INPUTS

The A22K can monitor the state of up to 6 devices (12 using zone doubling) such as magnetic contacts, motion detectors, temperature sensors, or other devices. The following are examples of the type of inputs that can be monitored:

Magnetic Door Contact:

Permits supervision of door "status" (opened, closed, opened too long, forced open). Inputs "Door Contact 1" and "Door Contact 2" are assigned by default. When a magnetic door contact is installed, the system can differentiate between a door forced open and an authorized exit.

Request to Exit (REX):

The device used can be a push button, vertical-view motion detector or floor mat sensor. Inputs "REX 1" and "REX 2" are assigned by default for Door 1 and Door 2 REX inputs respectively.

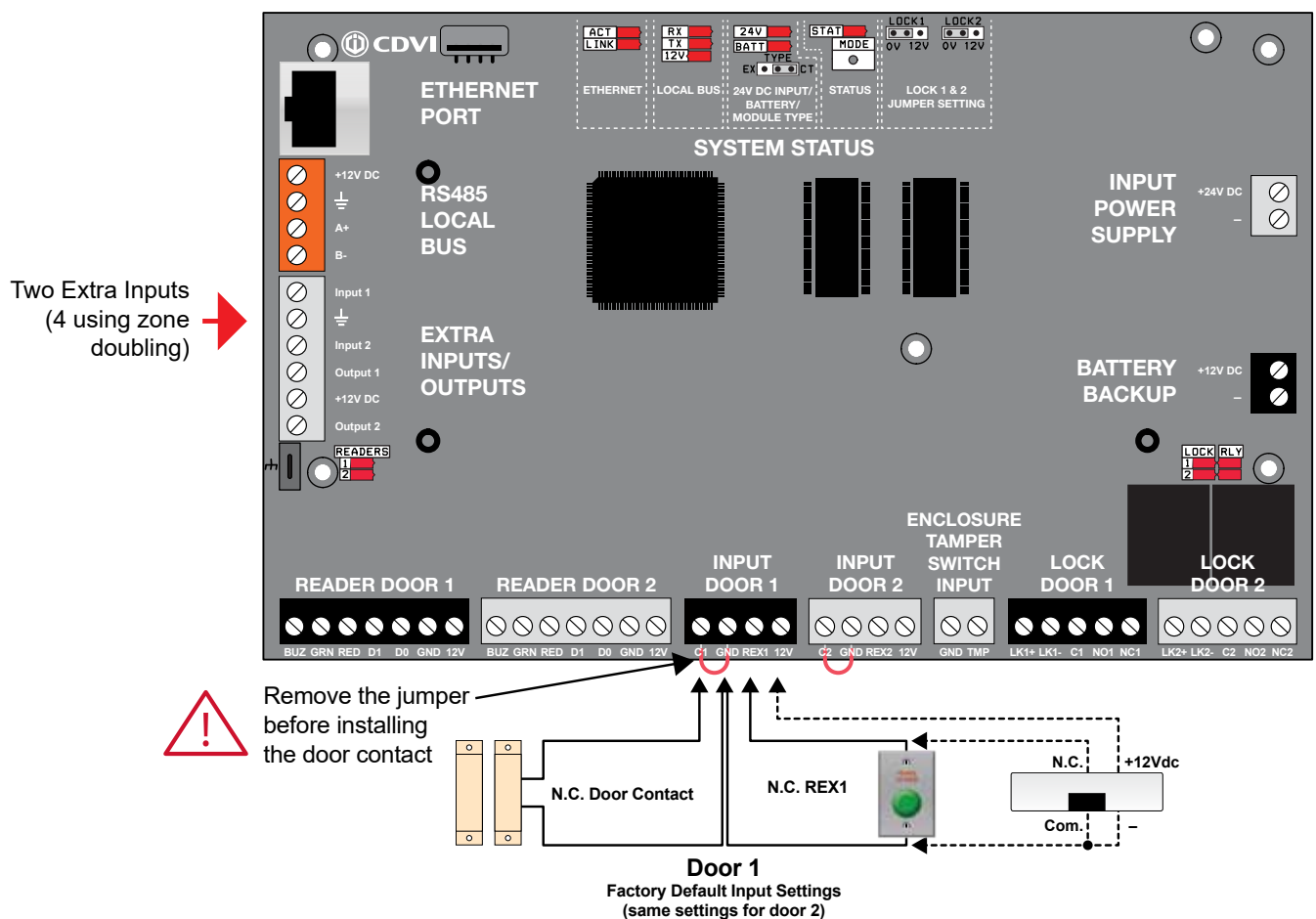

See "Recommended Wiring" section for more information on wiring type, size, and maximum length.

Examples of Input Connection Methods

Single (1 Detection Device per Input)

When using this method, only one device is detected by the input. Normally open or normally closed devices can be used. Normally closed circuit shown below.

Here are the different options for a single input configuration:

Single

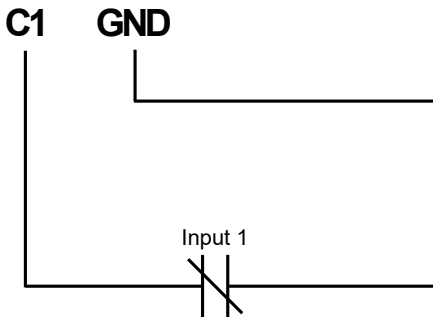

SHORT CIRCUIT supervision: No
WIRE CUT supervision: No
(Factory Default)

Single with short circuit (EOL) supervision

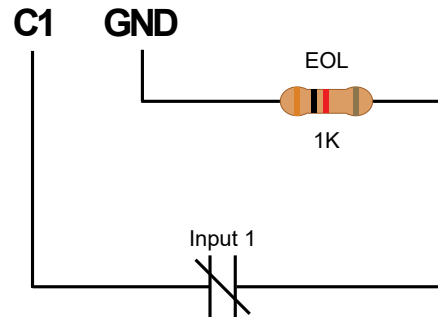

SHORT CIRCUIT supervision: Yes
WIRE CUT supervision: No

Single with wire cut supervision

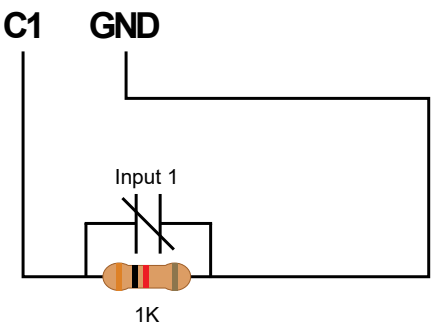

SHORT CIRCUIT supervision: No
WIRE CUT supervision: Yes

Single with wire cut and short circuit (EOL) supervision

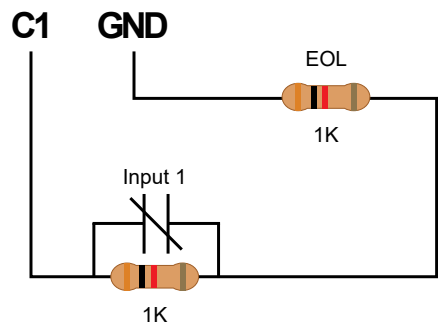

SHORT CIRCUIT supervision: Yes
WIRE CUT supervision: Yes

Doubled (2 Detection Devices per Input)

When using this method, two devices are detected by the input. Normally open or normally closed devices can be used. Normally closed circuit shown below.

Here are the different options for a double input configuration:

Doubled with wire cut supervision

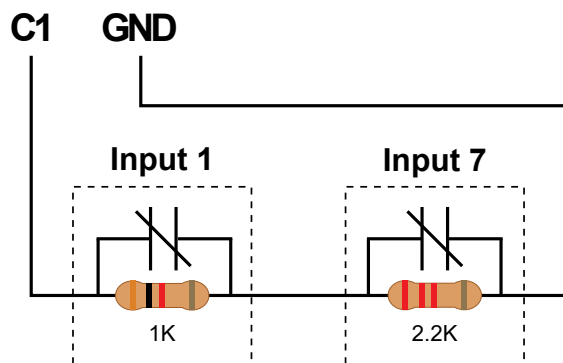

SHORT CIRCUIT supervision: No

WIRE CUT supervision: Yes

Doubled with wire cut and short circuit (EOL) supervision

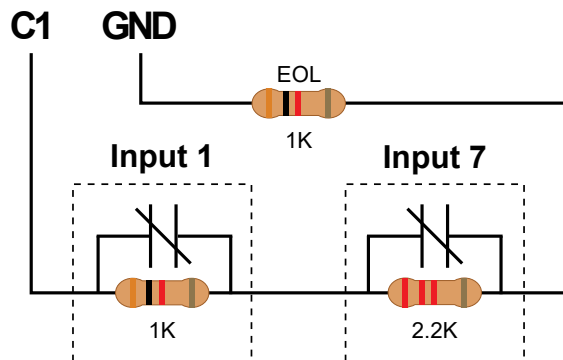

SHORT CIRCUIT supervision: Yes

WIRE CUT supervision: Yes

DOOR LOCK DEVICES

Each controller has two lock outputs. The LOCK OUTPUT can be configured to provide power (750mA @ 12Vdc), see "Jumper Settings" on this page, the LOCK OUTPUT is protected by a fuseless protection algorithm and will shutdown if the current exceeds 750mA @ 12Vdc. When a different voltage or more current is required, we recommend to use the RELAY OUTPUT configuration (see "Wiring Diagram of Locking Device", page 25).

- If you have one door with a reader on each side of the door, you can use either lock output.
- You can program the lock outputs to function in "fail-safe" (remove power to unlock a door) or "fail-secure" mode (power required to unlock a door).
- When using electromagnetic door locks or similar devices ensure that the current specifications are not exceeded.



Always consult the regulatory agency in your area for existing regulations regarding doors designated as emergency exits.

Jumper Settings

The jumpers LOCK1 and LOCK2 must be set according to the lock devices used (see "Wiring Diagram of Locking Device", page 25).

Lock Output Jumper Settings

There are two jumpers, one for each lock output, LK1 and LK2.
Each output provides 750mA at 12VDC

<p>Jumper Side View</p> <p>0V 12V</p>	<p>Default setting: The lock output will be at 0Vdc in normal state and toggles to 12Vdc during the unlock time. (De-energize lock output)</p>	<p>or</p>	<p>The lock output will be at 12Vdc in normal state and toggles to 0Vdc during the unlock time. This is the typical setting for electromagnetic door lock. (Energize lock output)</p>	<p>Jumper Side View</p> <p>0V 12V</p>
---------------------------------------	---	-----------	---	---------------------------------------

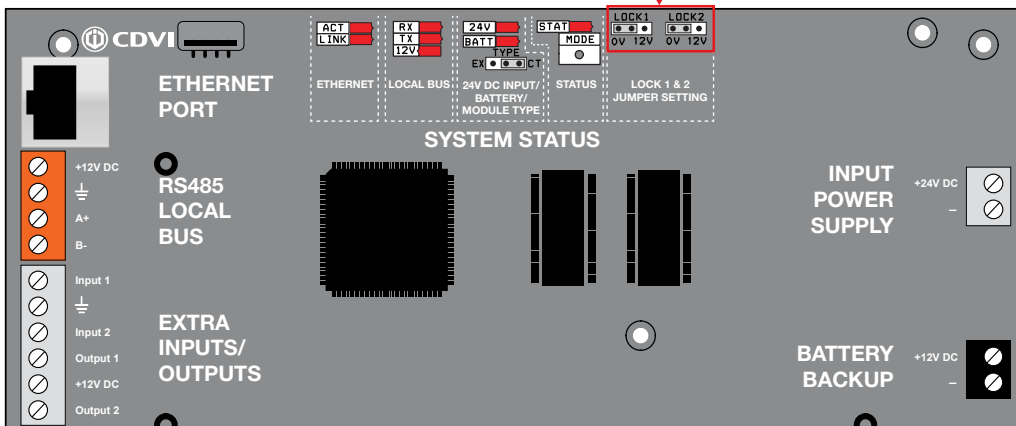

Lock Device Wiring Diagram Using On-Board Power Supply

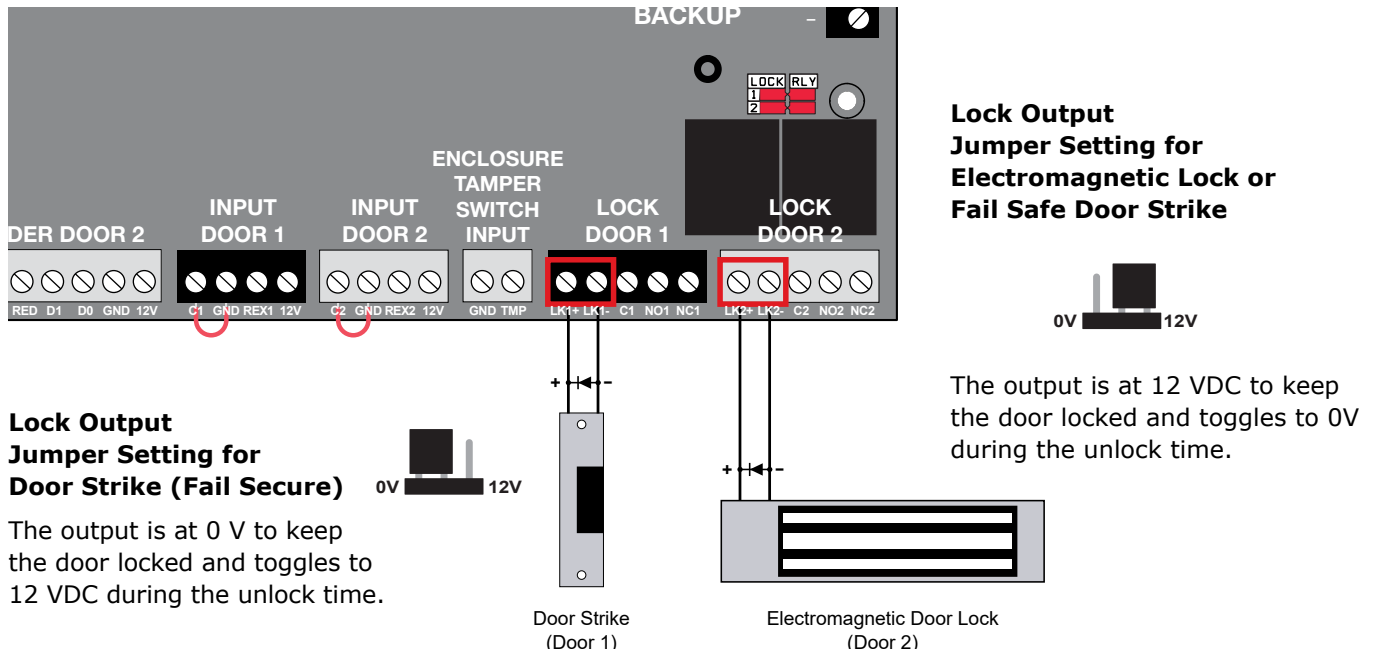

Each lock output provides 750mA at 12VDC. When a different voltage or more current is required, refer to the diagram below on how to connect an external power supply.

Lock Device Wiring Diagram Using External Power Supply

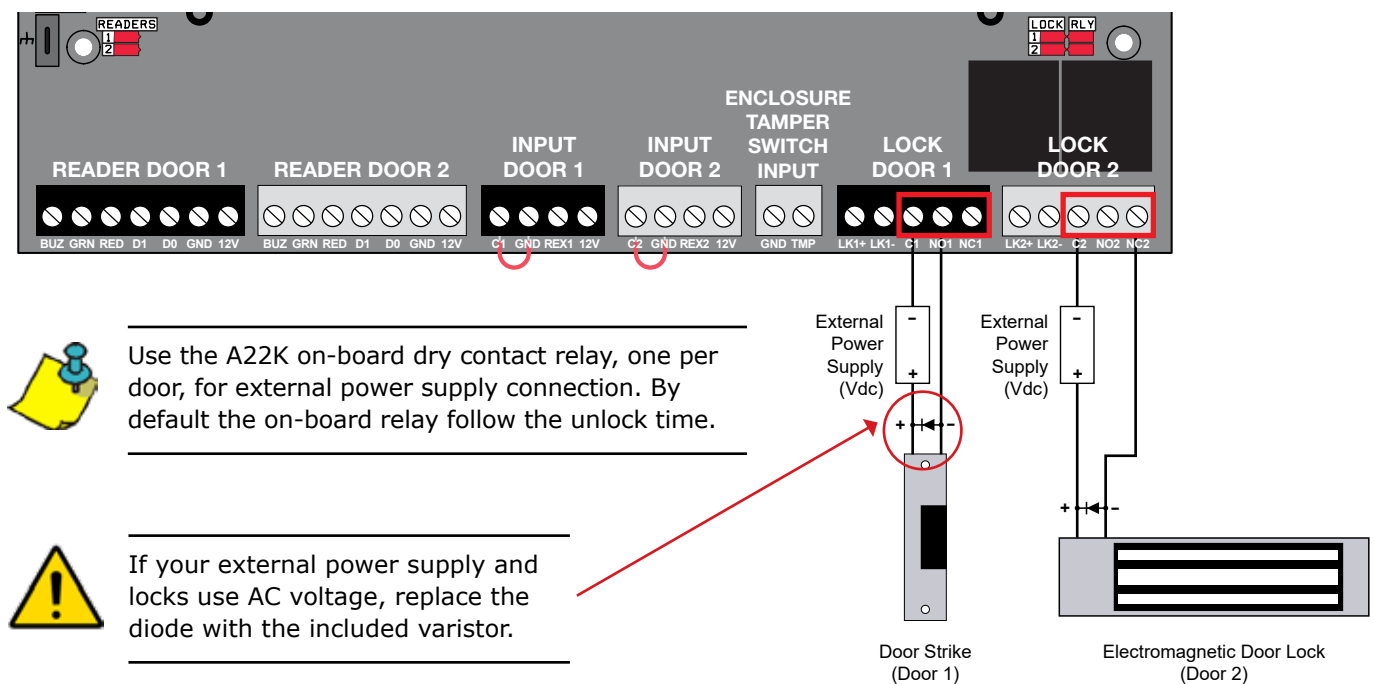

See "Recommended Wiring" section for more information on wiring type, size, and maximum length.

POWER SUPPLY



Do not power up the A22K until all connections are completed.

The module operates from any 120/240VAC source using the supplied AC/DC power supply and provides fully monitored power solutions using:

- Smart Battery Deep discharge prevention with automatic electronic cut-off.
- Programmable & Adaptive battery charging algorithm (250mA (default), 500mA, or 1A).
- Intelligent battery monitoring & charging algorithms allowing optimum performance using standard lead acid or gel cell type batteries.
- Real Time Monitoring algorithm for 'Battery Low/Disconnect/Reversal' and 'Insufficient Main Power'.

AC Source

The AC to DC power supply is pre-installed in the A22K enclosure but needs to be connected to the PCB. Simply plug the two pin terminal to the input power supply.

Universal Power Supply Diagram (A22K)

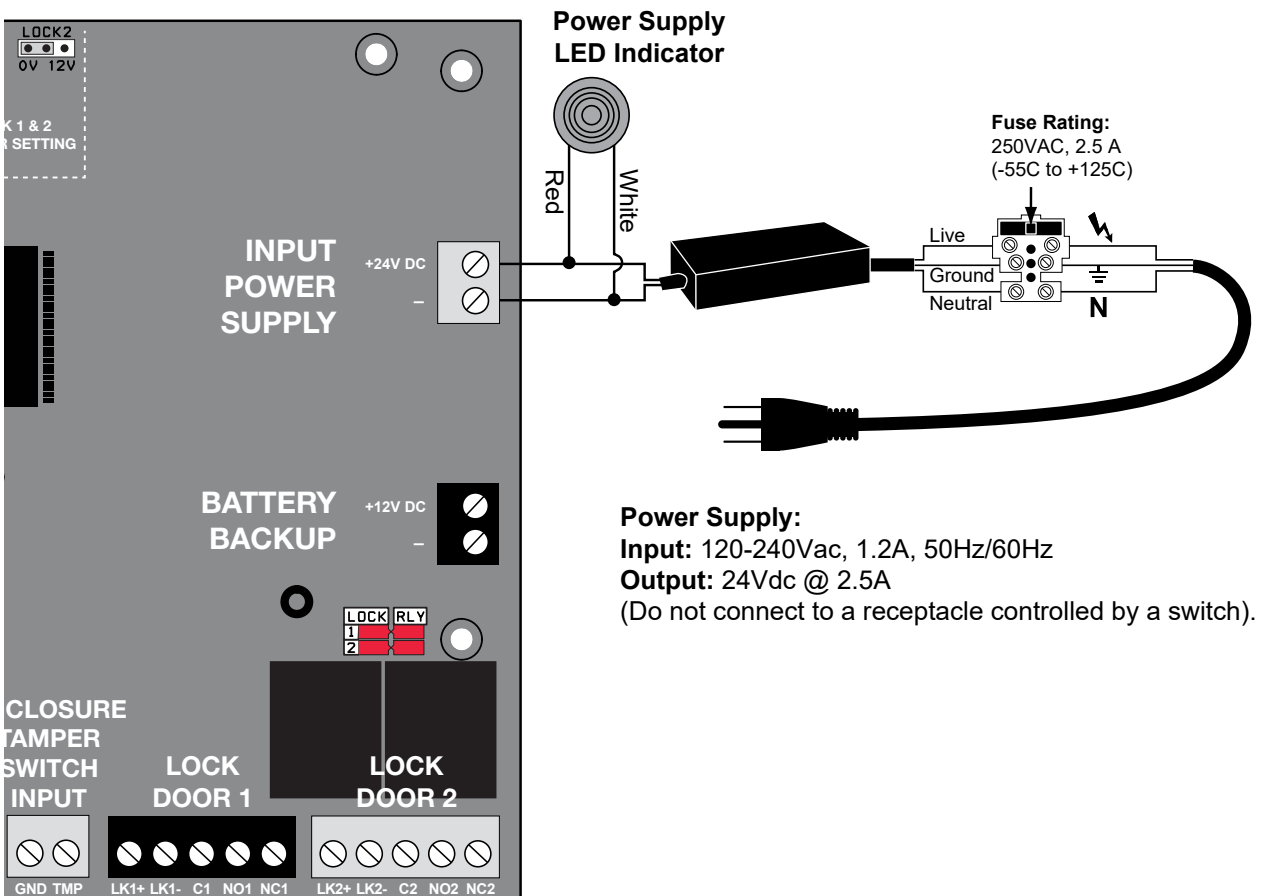

See "Recommended Wiring" section for more information on wiring type, size, and maximum length.



The Minimum Size Equipment Conductors for the AC mains required are 14 AWG if made of Copper or 12 AWG if made of Aluminum or Copper-Clad Aluminum. Do not use any switch-controlled outlets to power the system. The system is to be connected to a 15A receptacle or circuit.



For PERMANENTLY CONNECTED EQUIPMENT, a readily accessible disconnect device shall be incorporated external to the equipment.



For PLUGGABLE EQUIPMENT, the socket-outlet shall be installed near the equipment and shall be easily accessible.

AC Terminal Fuse



The following steps are only presented in case you need to replace the AC terminal fuse.

1. Disconnect the AC power cord from the power source or for permanent installation, turn off the power breaker¹.
2. Open the AC compartment at the top left to access the fuse holder.
3. Pull out the fuse holder.
4. Replace the fuse using the same fuse type:
 250V AC, 2.5 A, Time Lag, Slow Blow,
 Operating Temperature: -55°C to +125°C (-67°F to 257°F)

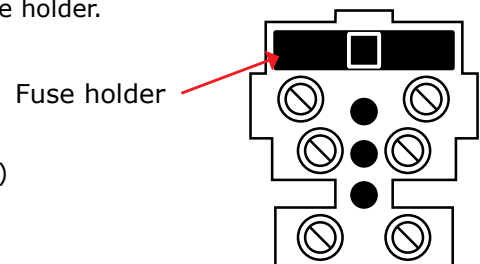

Permitted replacements:

- a) Littelfuse P/N 021802.5MXP
- b) Schurter P/N 0034.3121
- c) Various (means any type, from any manufacturer that complies with the "Technical Data and securement means" and meets the "Mark of conformity" can be used).

5. Replace the fuse holder in its location.
6. Close the AC compartment.
7. Connect the AC power cord to the power source or for permanent installation, turn on the power breaker¹.



¹ For permanent installation, this step must be done by a qualified technician in accordance with your local safety regulations.

PoE+ Power Supply Diagram (A22KPOE)

The PoE+ splitter to DC power supply is pre-installed in the A22KPOE box but needs to be connected to the PCB. Simply plug the two pin terminal to the input power supply.

PoE+S Splitter Features:

Interface

- 2-Port RJ-45 interfaces
 - 1-Port Data + Power input
 - 1-Port Data output
- 1-Port DC output power socket
- Output set to 24V DC (DIP switch)

Power over Ethernet

- Ultra Power over Ethernet End-Span / Mid-Span PSE (60W)
- IEEE 802.3at/af PoE standard compliant
- Supports 56VDC, 50p watt PoE power output
- Splits the 56V DC power over RJ-45 Ethernet cable into 24V DC output
- Remote power feeding up to 100 meters



Do not power up the A22POE until all connections are completed.

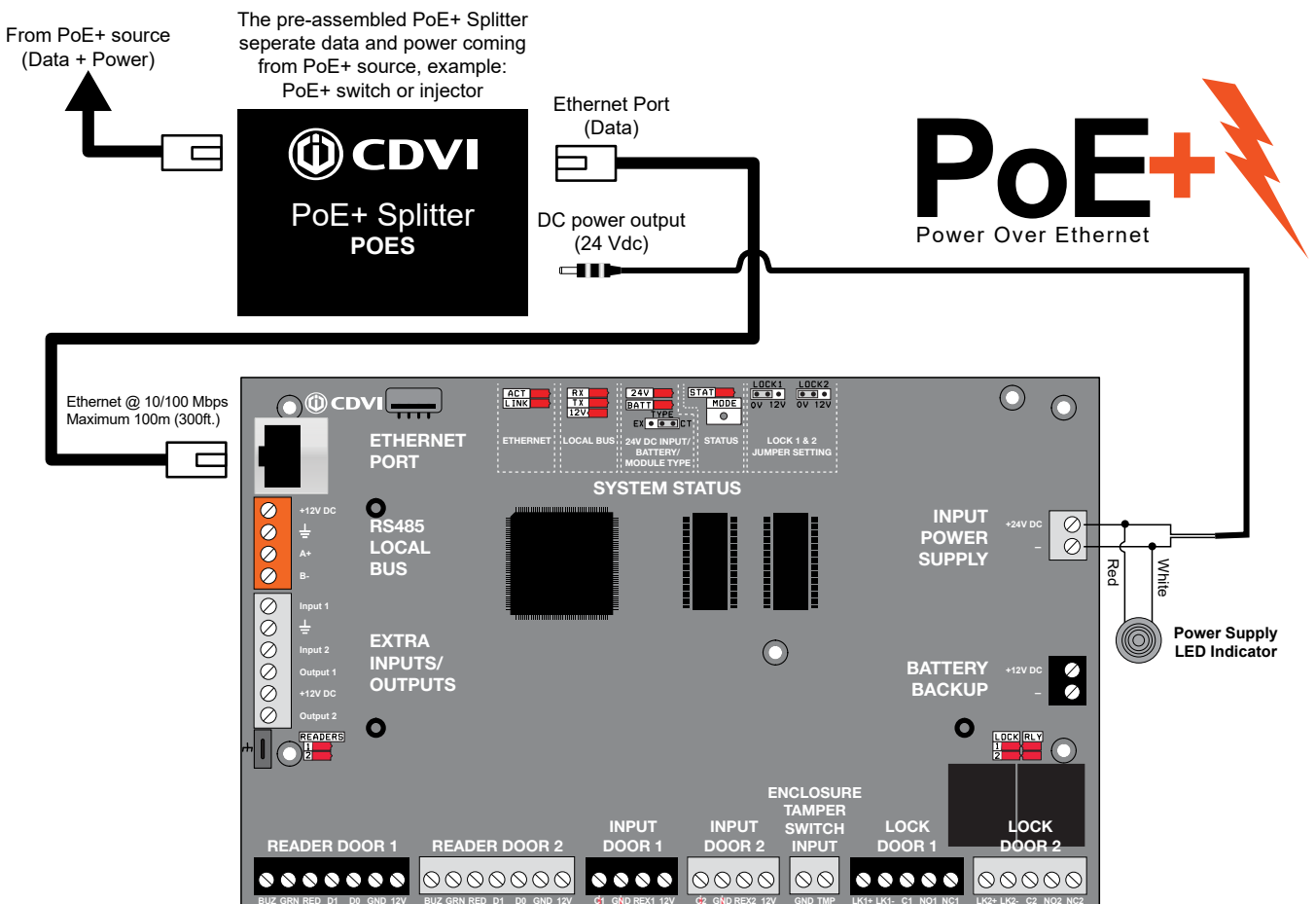

See "Recommended Wiring" section for more information on wiring type, size, and maximum length.

BATTERY BACKUP

The A22K cannot be started on battery power only. Battery backup time varies with each system. Typical backup time is between 4 and 20 hours using standard equipment and settings.

Wire a 12Vdc (either 4.5Ah or 7Ah) gel type battery and then connect it to the BATT "+" and "-" terminals with the battery leads supplied.

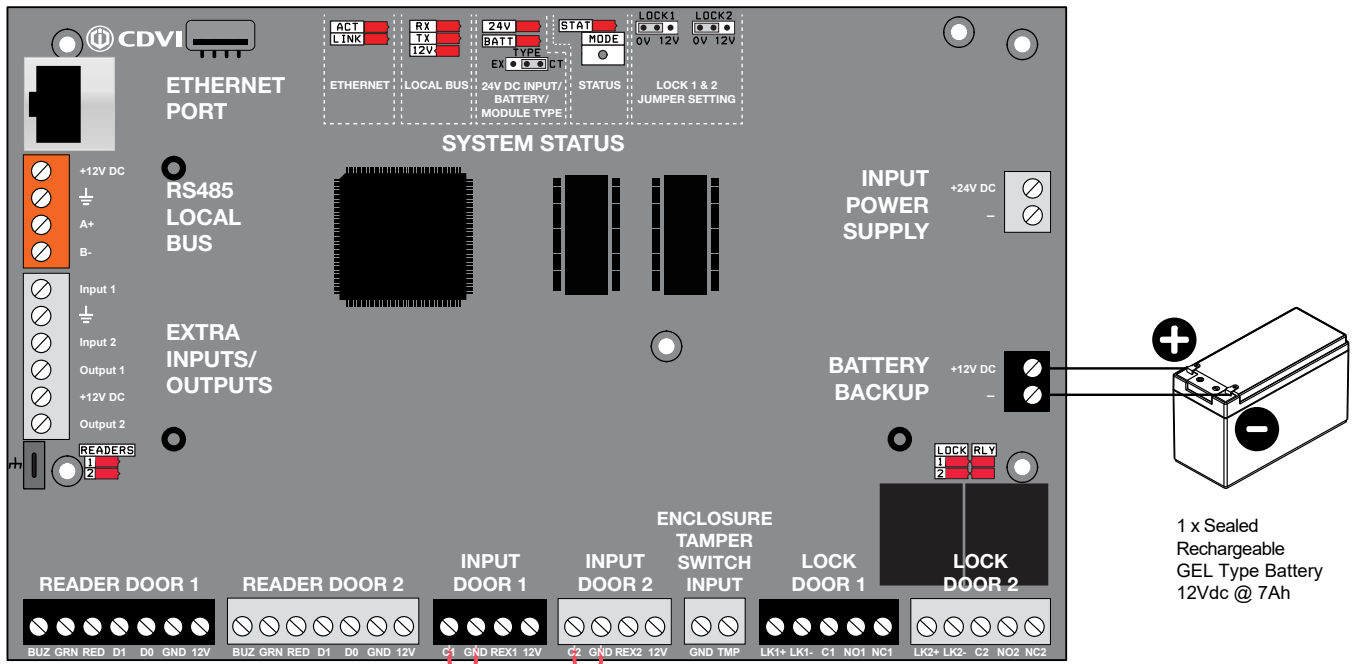

12V DC 7Ah rechargeable acid/lead or gel cell backup battery (UL/ULC: YUASA #NP7-12 recommended, Europe: CDVI B7AH recommended). Ensure proper polarity. Various (means any type, from any manufacturer that complies with the "Technical Data and securement means" and meets the "Mark of conformity" can be used).



The battery charge current can be set to either 250mA (default), 500mA, or 1A. Refer to the ATRIUM software to modify the battery charging current.

LED INDICATORS

The ATRIUM A22K has several status LEDs that are very useful to diagnose the ATRIUM system. Refer to the following picture to locate the LEDs on the ATRIUM A22K.

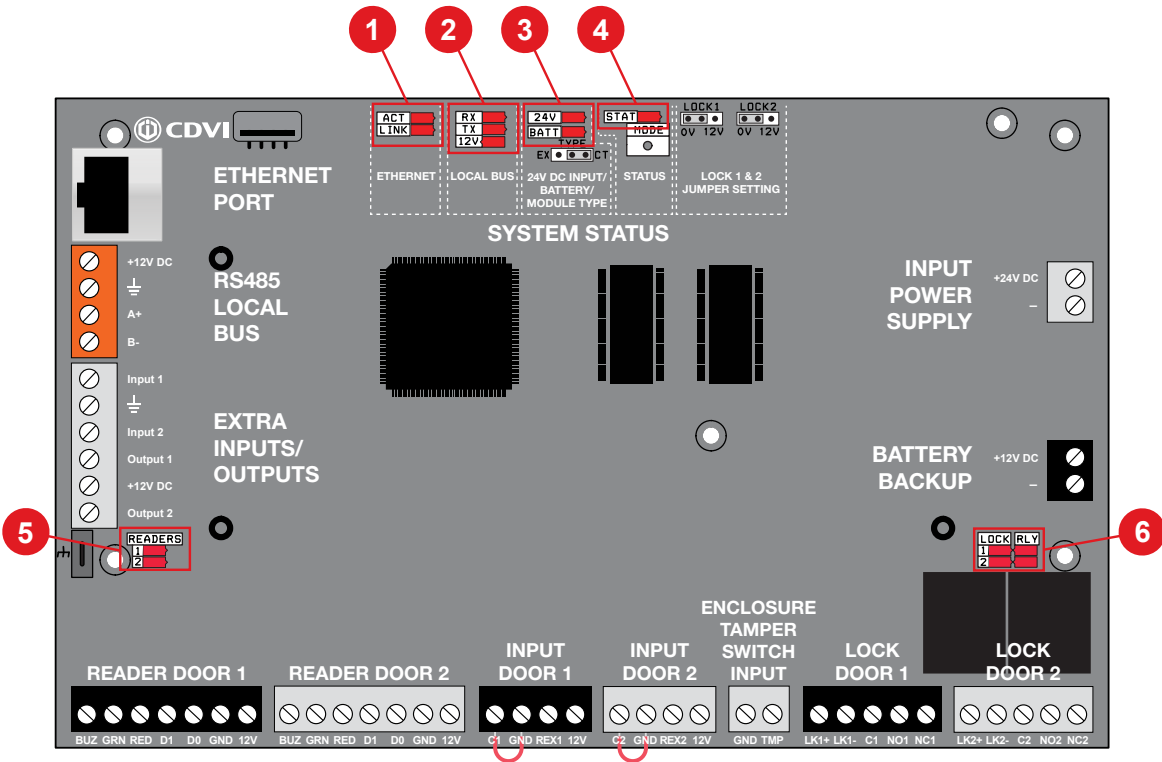

1	ETHERNET	ACT	Green LED flashing: Data transmitted/received.		
		LNK	Steady Green LED: Ethernet network detected.		
2	LOCAL BUS	RX	Green LED flashing: Data received on local bus.		
		TX	Green LED flashing: Data transmitted on local bus.		
		12V	Steady Green LED: 12V on local bus.		
3	24VDC INPUT / BATTERY	24V	Steady DC IN Green LED: A22K is powered properly. LED off: No primary power.		
		BATT	Green LED: On primary power present and battery charging.		
			Green LED Off Steady: Primary power present and battery full.		
			Red LED: No battery or battery not properly connected. Red LED flashing: Battery power is below 11.8Vdc.		
4	STATUS	STAT	Flash once per second: Firmware is operating normally. Flash rapidly: Firmware is upgrading. Blink once per 3 seconds: Card enrollment mode.		
		5	READERS	#1	Green LED flashing: Data received from Reader #1.
				#2	Green LED flashing: Data received from Reader #2.
6	LOCK & RELAY	LOCK 1	Green LED: Door 1 Lock Relay is active/triggered.		
		LOCK 2	Green LED: Door 2 Lock Relay is active/triggered.		
		RLY1	Green LED: Auxiliary Relay 1 is active/triggered.		
		RLY2	Green LED: Auxiliary Relay 2 is active/triggered.		

ETHERNET NETWORK CONNECTION & RS485 BUS

The ATRIUM A22K provides a 10/100Mbps Ethernet port to allow direct connection to a PC or to a LAN/WAN. Connect the Ethernet 10/100 Mbps port of the ATRIUM A22K to a LAN or WAN network using an UTP cable (maximum 100m (300ft)). Connect expansion modules on a 3 conductor RS485 communication loop in daisy chain or star configuration up to 1220m (4000 ft) from the ATRIUM A22K controller.

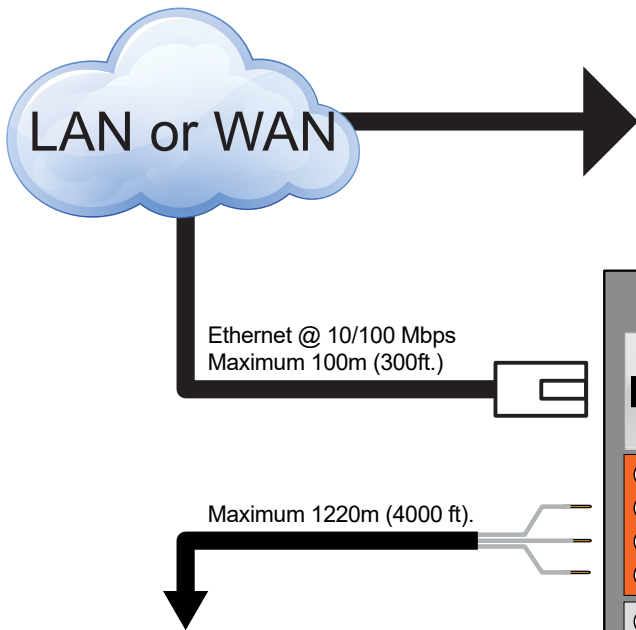

IP Port

The IP port is used to connect an A22K set as **“Controller”** on a network (LAN or WAN). System administrators will be able to configure, manage and monitor the system using the ATRIUM software (PC only) or web browser (PC or Apple) connected on that same network.

RS485 Port

The RS485 port is used to connect and communicate with an A22K set as **“Expander”** or any RS485 ATRIUM modules.

Up to 4 A22K set as **“Expander”** can be connected per RS485 port.

We highly recommended to use a twisted pair wiring as shown below.

It will avoid any communication problem that may occur in noisy environments.

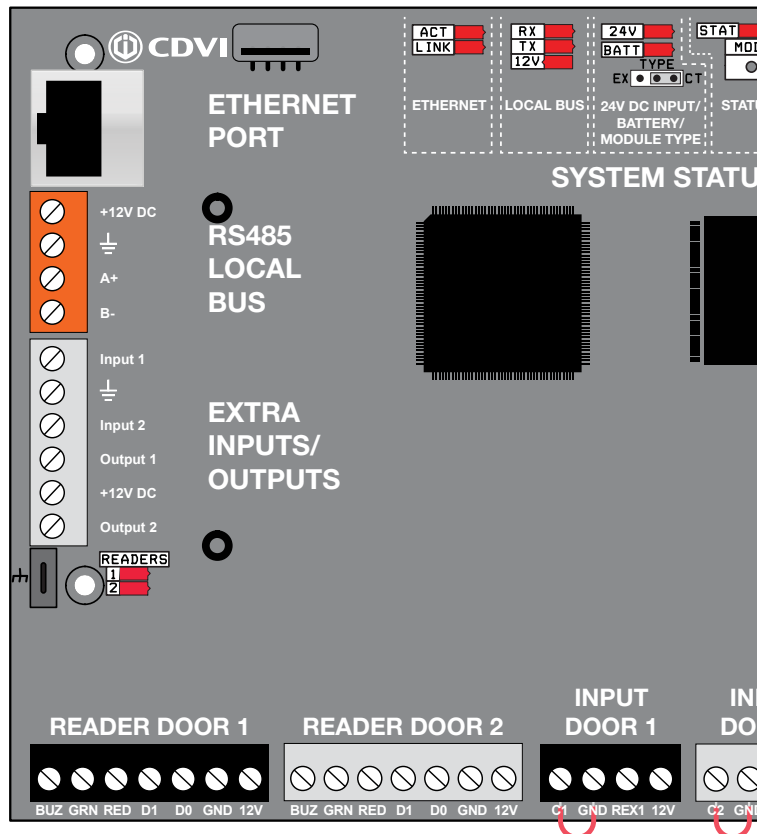

RS485 port connector

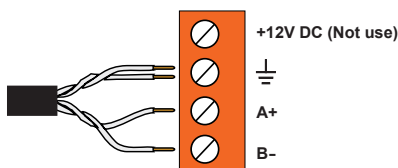

A22KPOE Wiring Diagram

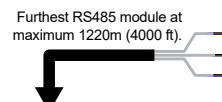
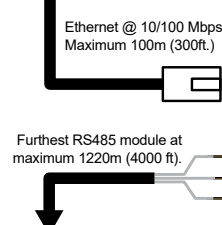
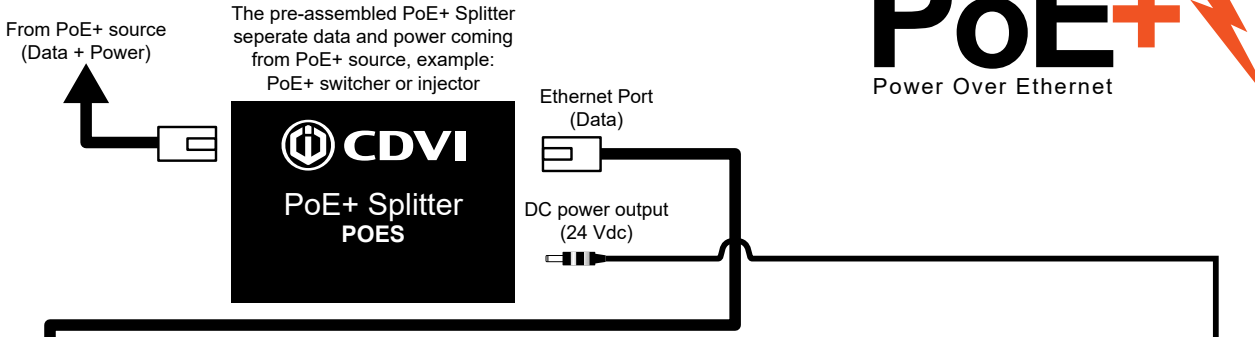

RS485 Port
 The RS485 port is used to connect and communicate with an A22K set as "Expander" or any RS485 ATRIUM modules.

Up to 4 A22K set as "Expander" can be connected per RS485 port.

We highly recommended to use a twisted pair wiring as shown below.

It will avoid any communication problem that may occur in noisy environments.

A22K RS485 port connector

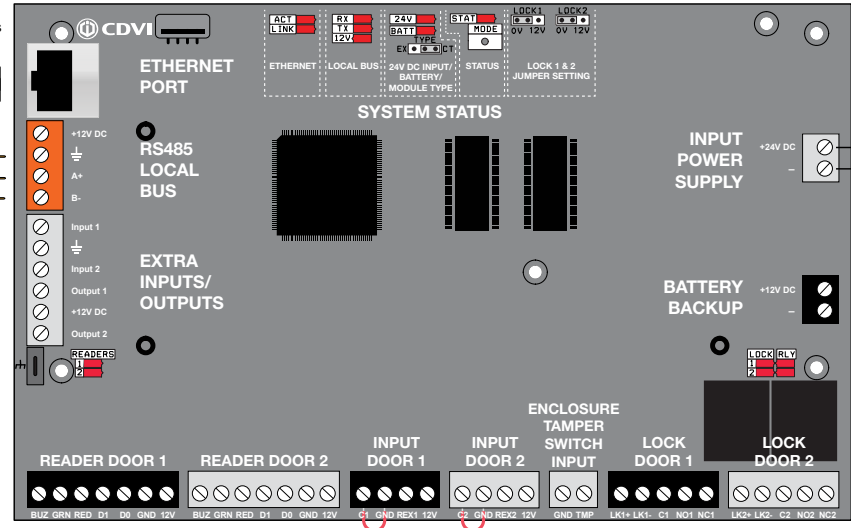
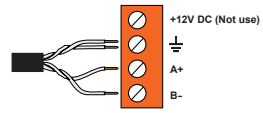

RESET TO FACTORY DEFAULT

Here are the steps to reset the A22K to the factory default settings:

- Press & hold the "MODE" button for ten "STAT" LED flash sequences (+/- 10 seconds), then release the "MODE" button.
- Approximately 2-3 seconds later, the "STAT" LED will blink twice
- Immediately press and hold the "MODE" button until the "STAT" LED blinks rapidly (+/- 5 seconds), then release the "MODE" button
- The controller will reboot and will be restored to factory default settings (+/- 30 seconds)

"STAT" LED & "MODE" button

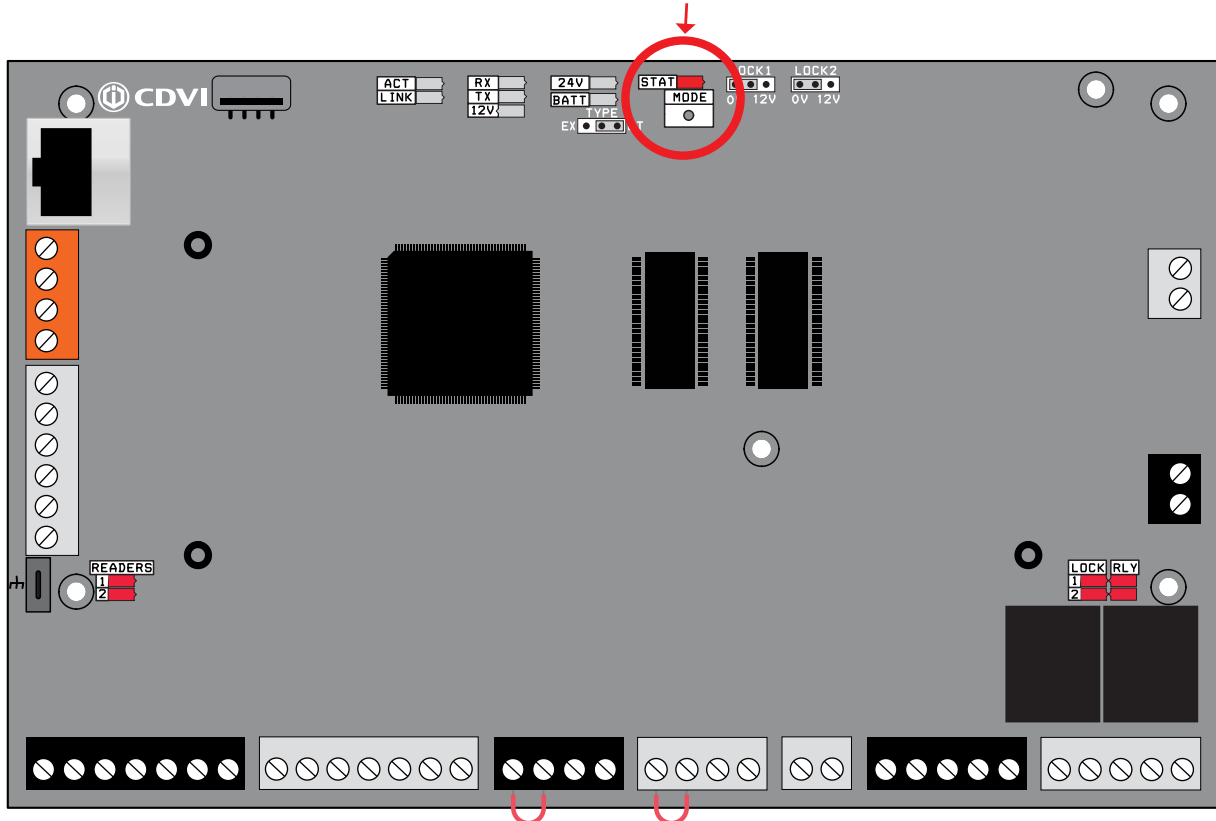

Events won't be deleted on a reset factory default of the A22K controller.

RS485 BUS TOPOLOGIES

The A22K has an RS485 LOCAL BUS terminal allowing the connection with an ATRIUM expander module. The RS485 LOCAL BUS communication is up to 1220 m (4000 ft) maximum distance. One A22K can support up to four A22K expansion modules. Refer to "Module type configuration (controller or expander)" on page 15 to set an A22K as an expander.

Connect the expander modules using these topologies:

DAISY CHAIN

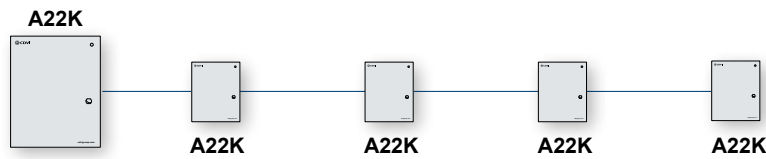

BUS

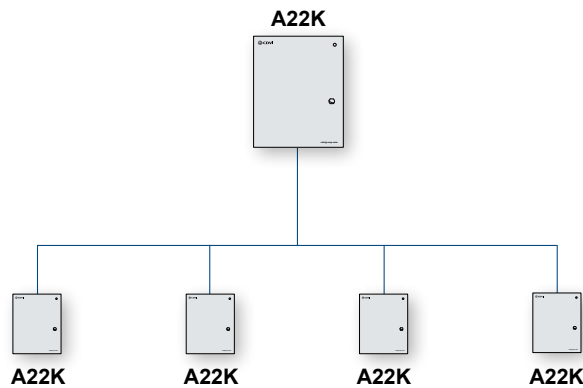

STAR

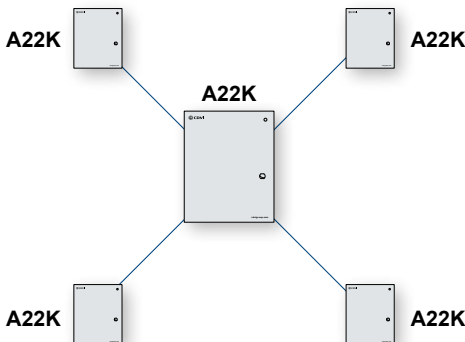

MIXED DAISY CHAIN/BUS/STAR

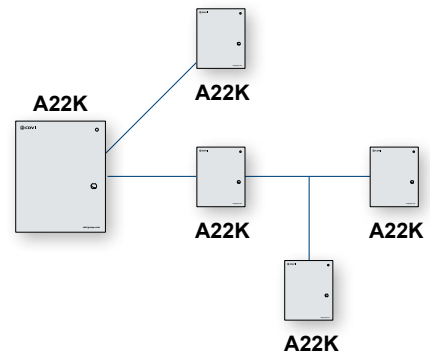

SYSTEM OVERVIEW

Supports any combination of fifty A22K, A22KEC and/or ADH10K controllers for a maximum of 500 doors

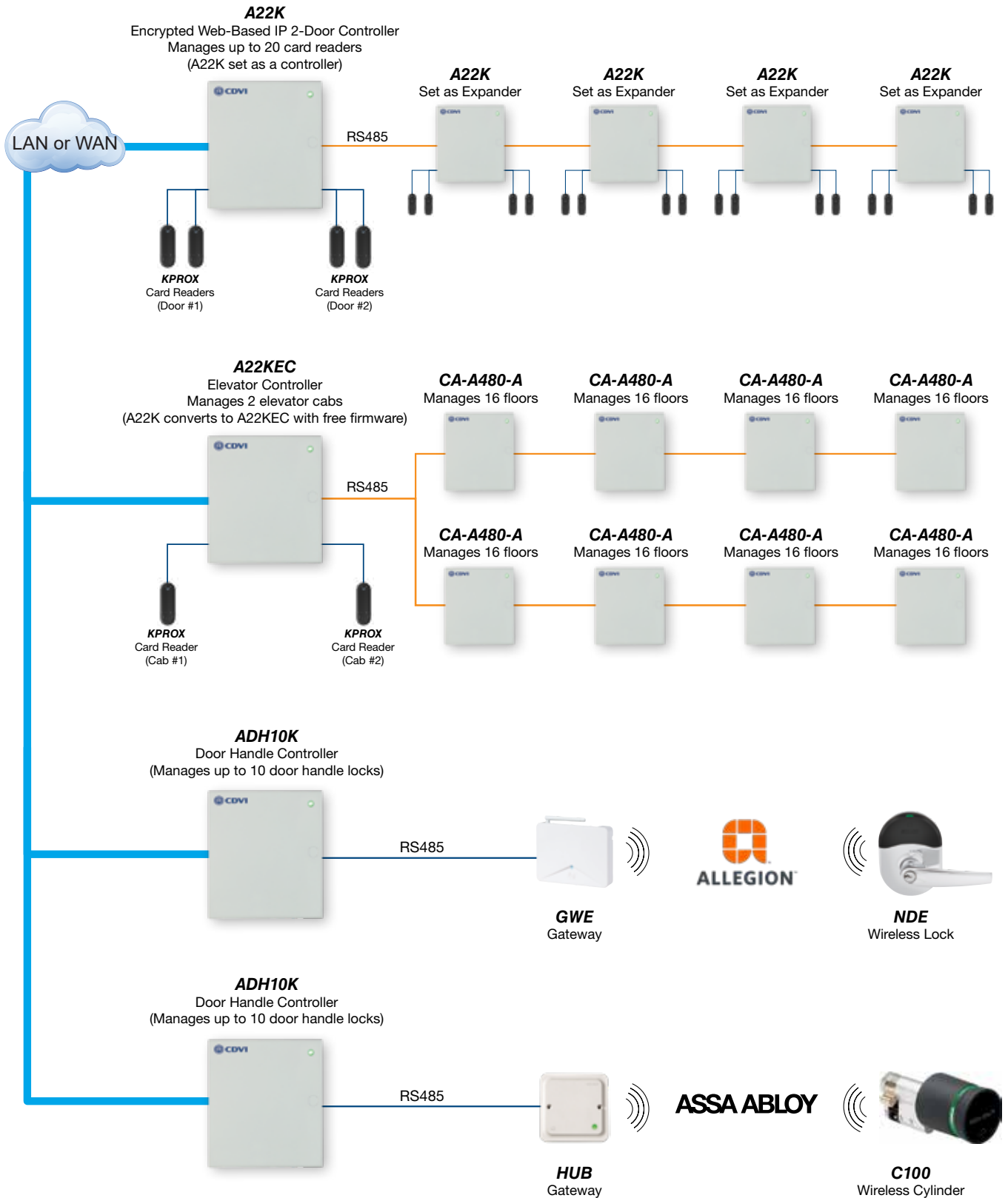

6] PROGRAMMING

The stand-alone card enrollment allows you to add or delete user cards at a reader. To use this function, you must create a MASTER card and a PROGRAMMING card.

Scan the QR code for the "Create a MASTER & PROGRAMMING Card" guide or access it by [clicking here](#). Then follow the steps below.



CARD ENROLLMENT PROCEDURE (ADD OR DELETE CARDS WITHOUT A COMPUTER).

1. Present the MASTER card to a reader.
The door will unlock.
2. Within 5 seconds, present the PROGRAMMING card to the reader.
Reader LEDs will begin flashing in sequence
(2 Red flashes + 2 Green).
Enrollment mode is active.
3. Present cards, one by one, to the reader.

NEW cards will be ADDED.

Green LED will flash and a quick beep will be emitted.

Each new card will create a user and attribute the card to the user

EXISTING cards will be DELETED.

Red LED will flash and a long beep will be emitted.



4. Present the PROGRAMMING card again to stop enrollment mode.
The flashing sequence (2 Red flashes + 2 Green) will stop.

The card enrollment learning mode ends when no new card is presented for 5 minutes.

For other card enrollment methods, refer to the "ATRIUM Software" manual.

7] Warranty - Terms & Conditions

The "5-Year Warranty" is offered by CDVI exclusively for CDVI products featuring the logo "5-Year Warranty", and supplied by authorized CDVI dealers participating in the offer. You can obtain the address of the local authorized dealer participating in the offer by contacting CDVI or a local CDVI subsidiary. The "5-Year Warranty" is only applicable to hidden defects detected during the lifetime of the product, as defined by the CDVI Group (5-years or 200 000 operations - whichever of the two expire first).

The "5-Year Warranty" conditions shall not modify the sales conditions between CDVI and its customers.

DURATION OF THE OFFER:

- This offer is valid from July 1st 2010; CDVI reserves the right to terminate this offer without prior notice.
- However, any product already registered up to the date of withdrawal of the offer will remain eligible for the "5-Year Warranty".
- The warranty applies only to the available products mentioned in the above statement.

CONDITIONS:

- Hidden defects are guaranteed for an unlimited shelf life (period of time before use).
- The "5 Year Warranty" only applies to products installed by a skilled and experienced personal with the necessary trade qualifications to install according to the highest standards, respecting the standards, instructions and guidelines defined by CDVI and according to the maximum recommended specifications.
- To enable CDVI to determine whether a product is eligible to claim for the "5-Year Warranty", after prior issue of a return of materials authorization number (RMA) by CDVI, the customer must return the product and all of its accessories in the original packaging with a copy of its invoice. The transport fees shall be paid by the customer and the package must be returned to CDVI or to a CDVI authorized repair centre.
- Eligibility for the "5-Year Warranty" cover must be confirmed by CDVI.
- The "5-Year Warranty" only covers the replacement or repair of the parts acknowledged as faulty by CDVI.
- CDVI reserves the right to respect its obligation by replacing the product or the parts acknowledged as faulty by a standard part replacement or by a product or new parts, or by an updated or improved version of the product with identical or similar functionalities.
- In respect of the applicable law, CDVI cannot be held responsible for material or immaterial damages caused to goods or to third parties and as a direct or indirect result of the installation, utilization, product faults or poor functioning of a device.
- The "5-Year Warranty" is non-assignable and non-transferrable.
- The "5-Year Warranty" is limited to the eligible product and is strictly limited to the conditions in effect on the date of purchase by the customer.



CDVI AMERICAS

[CANADA - USA - LATIN AMERICA]
www.cdvi.ca

CDVI BENELUX

[BELGIUM - NETHERLAND - LUXEMBOURG]
www.cdvibenelux.com

CDVI CHINA

CDVI FRANCE

www.cdvi.com

CDVI IBÉRICA

[SPAIN - PORTUGAL]
www.cdviberica.com

CDVI ITALIA

www.cdvi.it

CDVI MAROC

www.cdvi.ma

CDVI POLSKA

www.cdvi.com.pl

CDVI SUISSE

[SWITZERLAND]
www.cdvi.ch

CDVI SWEDEN

[SWEDEN - DENMARK - NORWAY - FINLAND]
www.cdvi.se

CDVI UK

[UNITED KINGDOM - IRELAND - SOUTH AFRICA]
www.cdvi.co.uk

www.cdvi.com