

# HUANCHACA RUINS

Location: Antofagasta, Chile

Architect: Ramon Coz & Associates

Date: 2017

## 02

Date: 04-29-22

Author: Jacob Barbarossa

### 01

#### CONTEXT

//////////////// 01.0 Site History

### 02

#### DESIGN

//////////////// 02.0 Plans & Section

### 03

#### FUNCTION

//////////////// 03.0 Light Study

//////////////// 03.1 Model

### 04

#### VISUAL

//////////////// 04.0 Photo 01

//////////////// 04.1 Photo 02

Compania Minera de Huanchaca,  
Antofagasta, Chile

### Historical Significance

Once a prosperous silver refinery, the Huanchaca Ruins were built in 1888 by Compania Minera de Huanchaca, one of the wealthiest mining companies of the late 1800s. However, as taxes increased in the region and the requirement of the railroad became a burden, the mining company decided to cut their losses and move. After more than a century, the natural erosion of the structures gave them the appearance of ancient ruins, attracting locals and tourists alike.

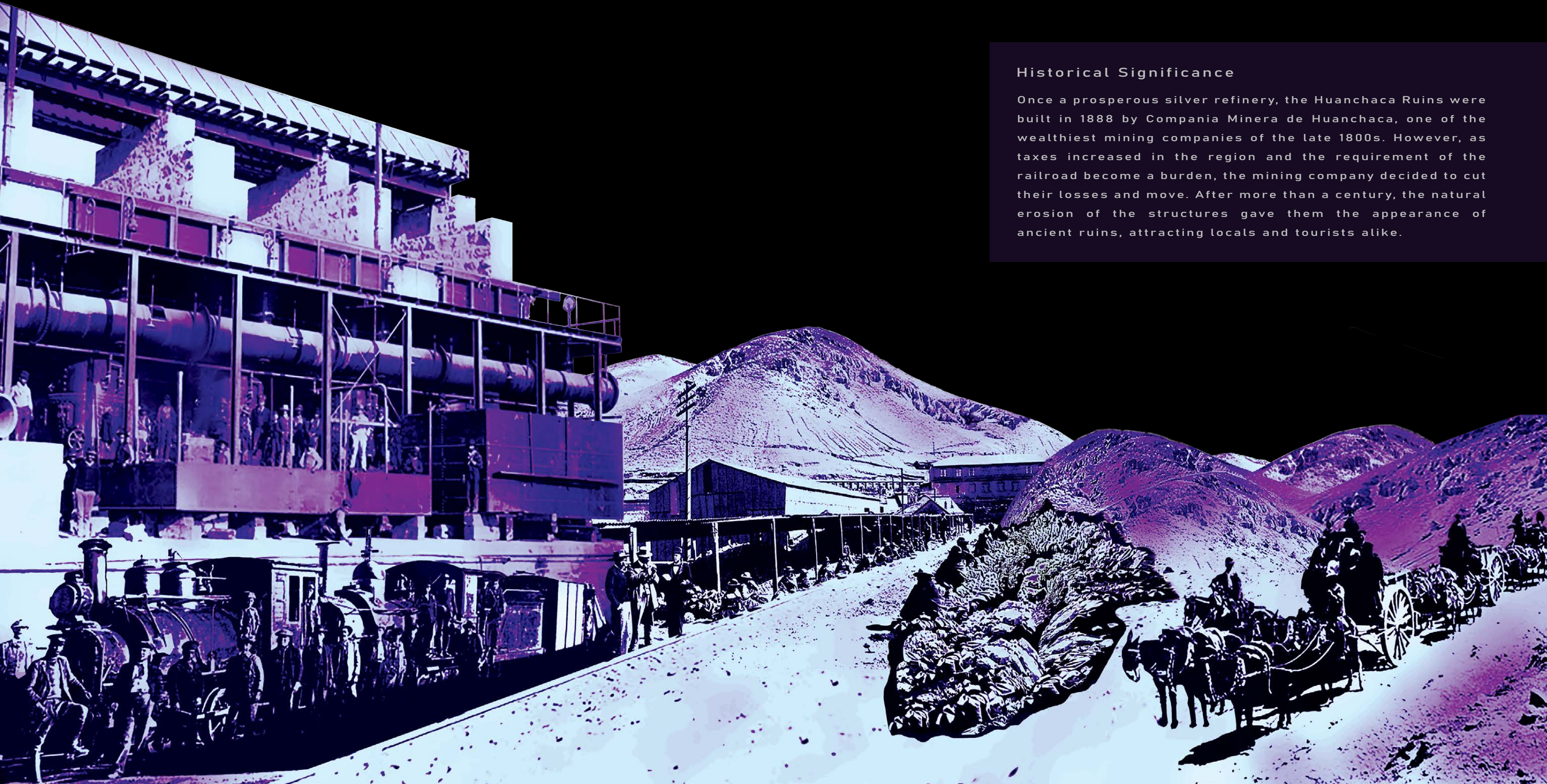

////////// Floor Plans & Section

Antofagasta, Chile

23°41'06"S 70°24'46"W

Utilizing the topographic conditions of Huanchaca Cultural Park and a minimalist approach, the open-air-theater emerges from the ground as a natural element.

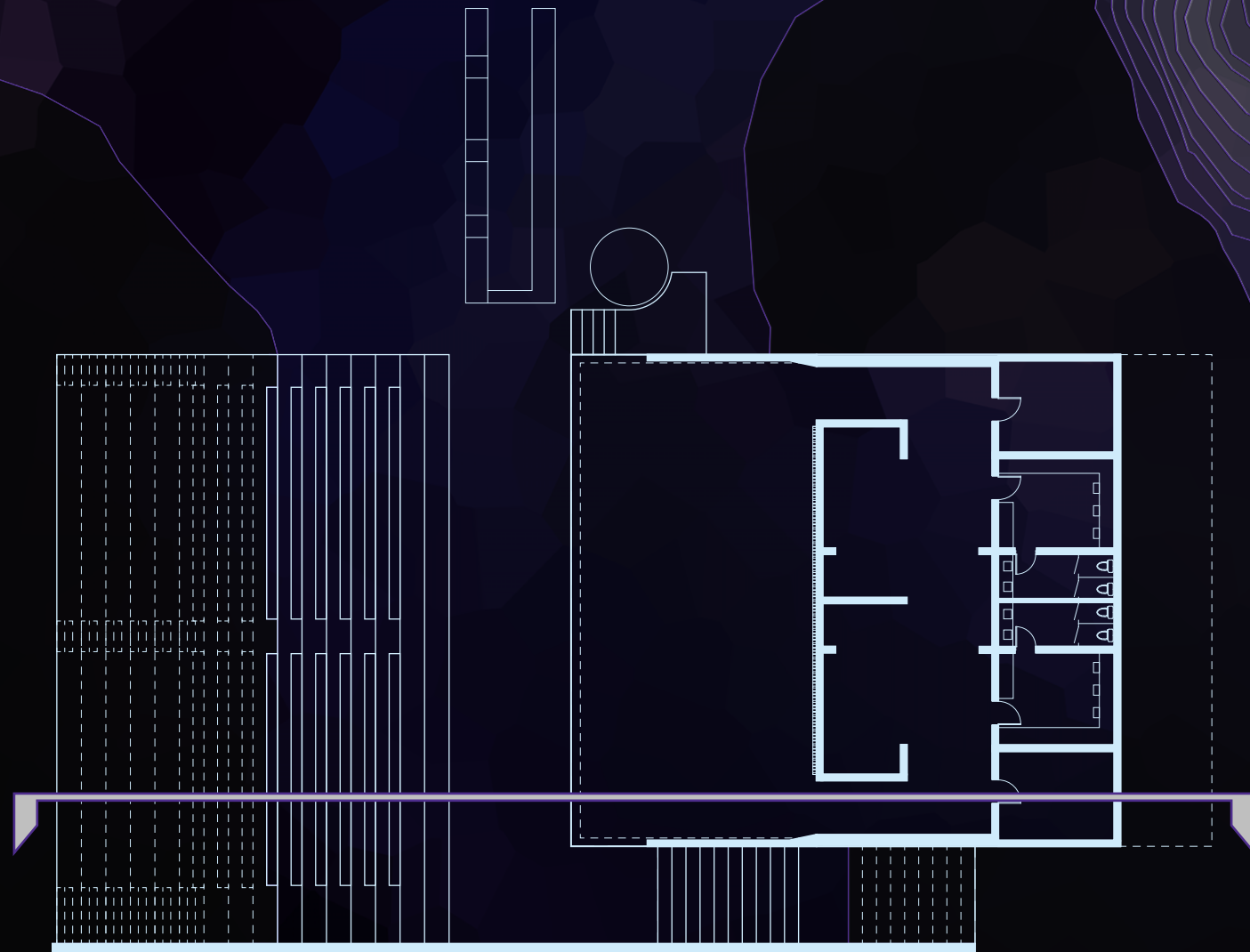

Floor 1

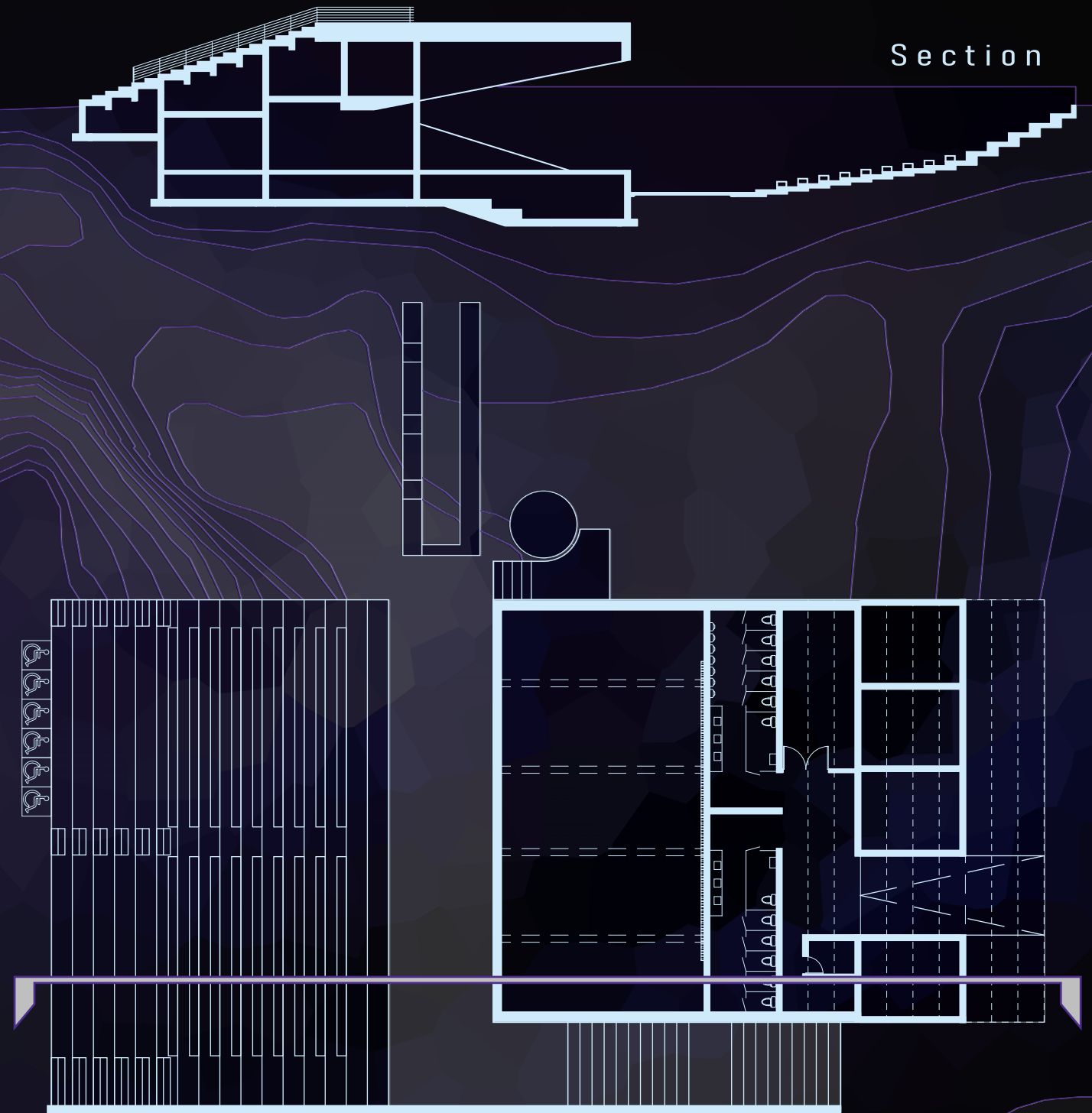

Section

Floor 2



Light Study

Antofagasta, Chile  
23°41'06"S 70°24'46"W

Winter Sun  
Summer Sun



Winter Months June - September

Summer Months December - March

[MODEL]

[SHADOWS]

[HIGHLIGHTS]

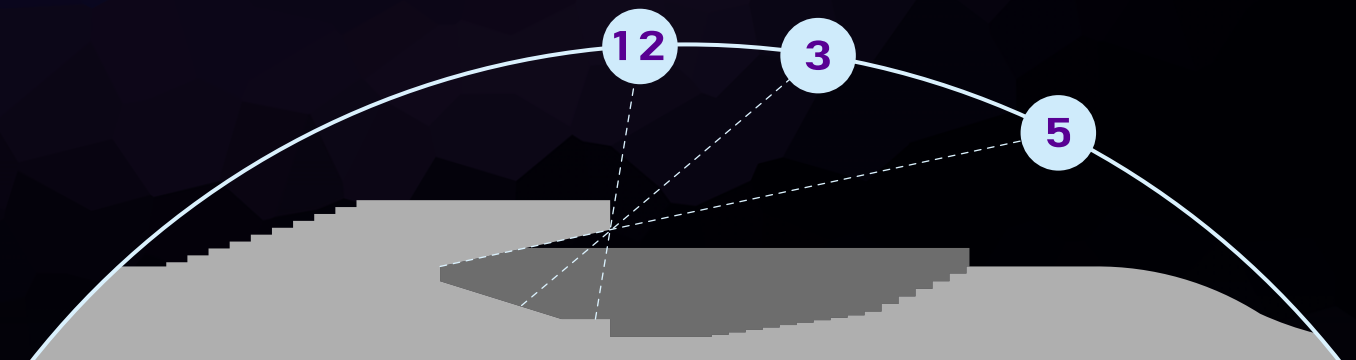
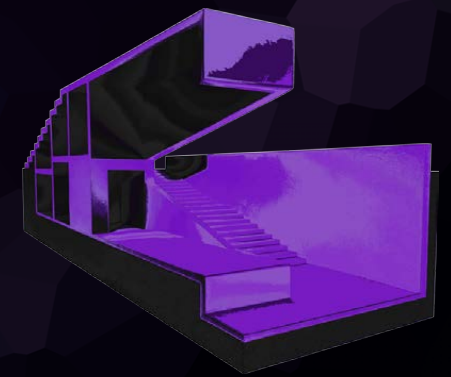
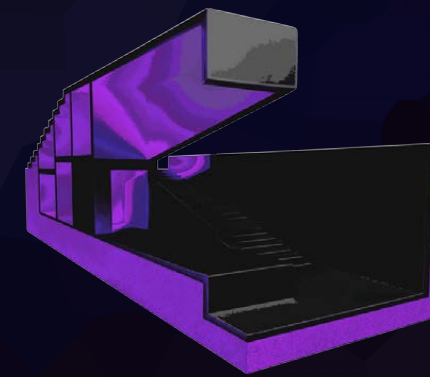
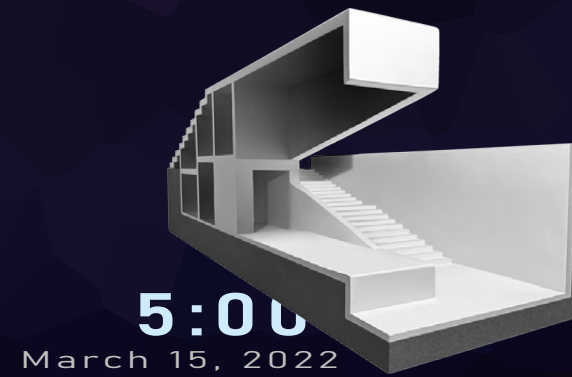
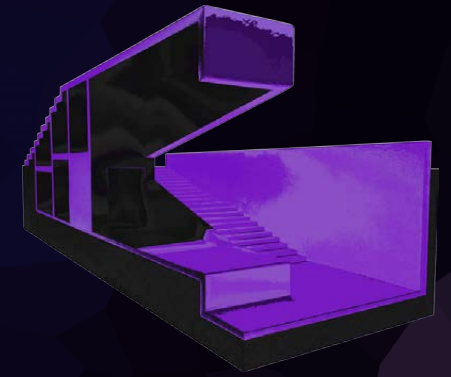
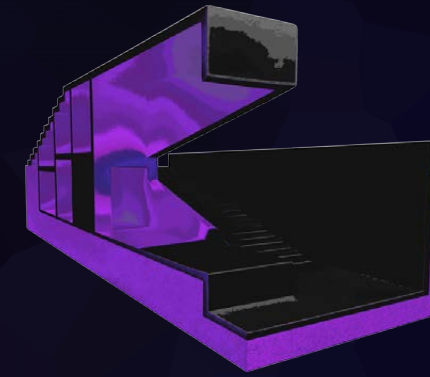
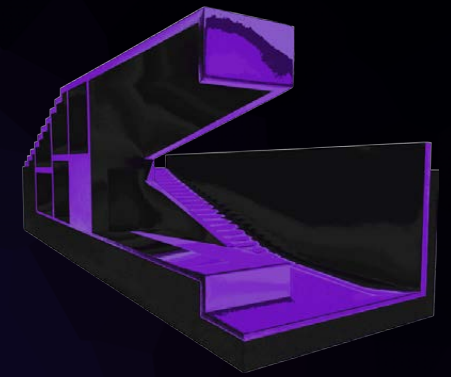
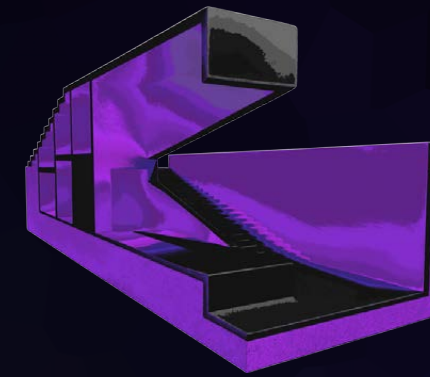
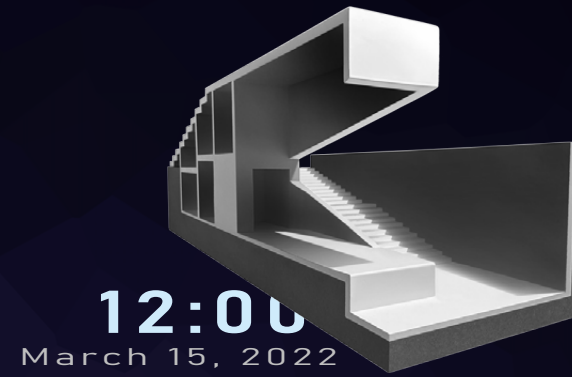

Huanchaca Ruins  
Antofagasta, Chile

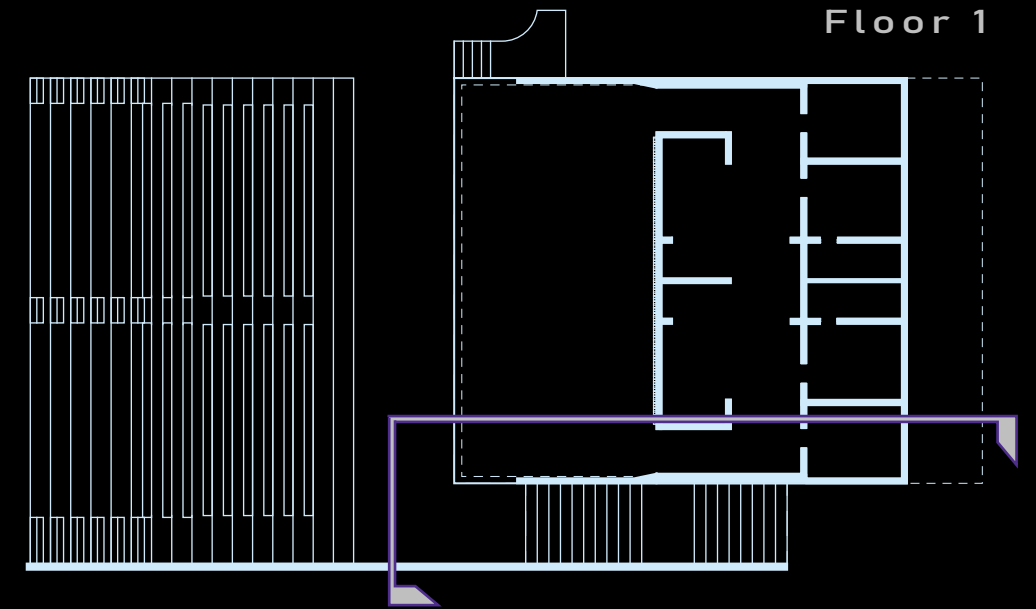
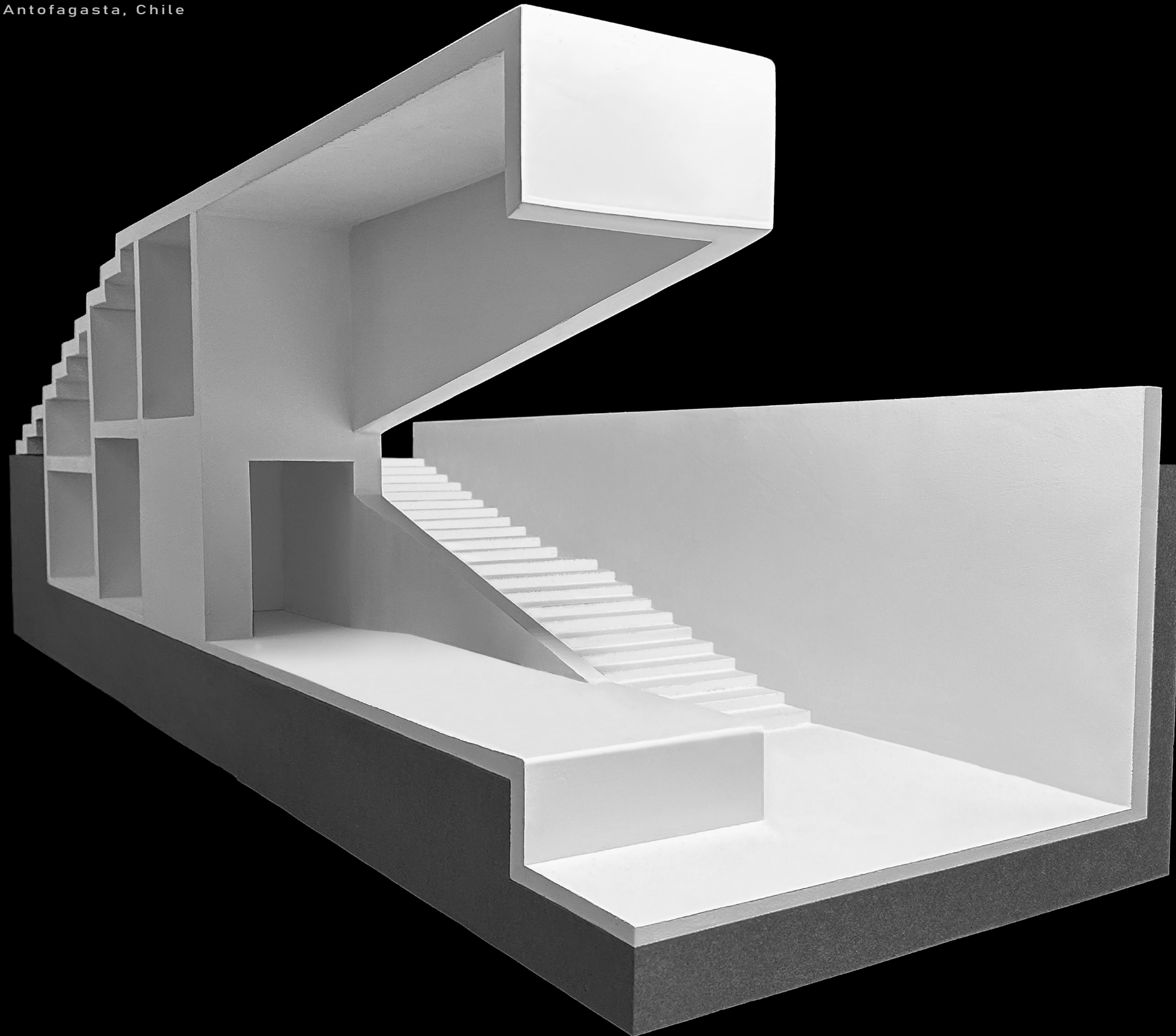

Axonometric Model

A physical axonometric model was determined to be the best form of study for sunlight conditions. Using plaster, the model was able to replicate the rough texture found in cast concrete that the actual theater utilized throughout it's construction, providing a reliable source of study.

Open-Air-Theater  
FUNCTION



Sergio Pirrone. Huanchaca Ruins. Arch Daily. 2017.  
<https://www.archdaily.com/908451/huanchaca-ruins-open-air-theatre-ramon-coz-plus-benjamin-ortiz>



# HUANCSHACA RUINS

